



EN

LOW NO<sub>x</sub> PRESSURISED STEEL BOILERS

## GREENOx .e

WITH THREE GAS PASSES



*La figura riportata è puramente indicativa*

## GREENOx .BT COND

LOW RETURN TEMPERATURE WITH CONDENSER



INSTALLATION, USE AND MAINTENANCE MANUAL



GREENOx\_en\_00 - 10/2021

## INDEX

1. INTRODUCTION .....	3
2. SAFETY WARNINGS.....	3
3. GENERAL WARNINGS .....	6
4. TECHNICAL SPECIFICATIONS .....	7
GREENOX.E 10 ÷ 70 BOILER.....	7
GREENOX.E 80 ÷ 300 BOILER.....	9
GREENOX BT COND BOILER.....	11
5. INSTALLATION .....	12
THERMAL PLANT .....	12
HYDRAULIC CONNECTION.....	13
ELECTRICAL CONNECTION .....	14
OPTIONAL CONTROL PANEL.....	14
INSTALLATION OF GREENOX.E 80 ÷ 300 BOILER CONTROL PANEL .....	15
DOOR.....	17
BURNER CONNECTION .....	19
6. ASSEMBLY .....	20
BOILER CASINGS AND CONTROL PANEL .....	20
7. START UP.....	24
PRELIMINARY CHECKS.....	24
WATER TREATMENT.....	24
FILLING THE SYSTEM.....	24
8. OPERATION .....	25
OPERATING CHECKS .....	25
9. MAINTENANCE .....	27
PREPARATION FOR INSPECTION AND MAINTENANCE.....	27
ORDINARY.....	28
10. ENVIRONMENTAL PROTECTION AND DISPOSAL.....	28
11. INFORMATION FOR THE DISPOSAL OF ELECTRICAL AND ELECTRONIC EQUIPMENT.....	28
12. USEFUL INFORMATION AND DECLARATIONS.....	29
13. NOTES .....	31

# 1. INTRODUCTION

Dear Customer,

Thank you for having chosen our **generator**.

**In your interests, we invite you to follow and observe the instructions in this manual to ensure the highest level of efficiency and duration of the unit.**

IMPORTANT: failure to observe the instructions in this manual will void the warranty conditions.

# 2. SAFETY WARNINGS

## IMPORTANT

**For safety and for proper operation, carefully read this TECHNICAL MANUAL before installing and starting the generator. The manual is an integral and essential part of the generator and must accompany it from installation until disposal. The generator must be used for the purpose for which it was strictly intended and any liability by the Manufacturer for damages to people, animals or property due to lack of maintenance or for improper use, is excluded.**

## Safety of the thermal power plant

For safety purposes, the qualified technical personnel in charge of running the system must consider the following requirements:

- Follow the accident prevention and environmental safety regulations in force.
- Ensure the generator installation in the thermal power plant complies with the standards in force.
- Ensure that the electrical and hydraulic system complies with the standards in force.
- Ensure that the boiler room complies with the standards in force and is sufficiently ventilated.
- Ensure that the boiler fumes are conveyed outside the thermal power plant through a flue compliant with the standards in force.
- Ensure that the acidic condensation that may develop during system start-up, is evacuated outside the thermal power plant after a neutralisation process in compliance with the standards in force.
- Ensure that there is no danger due to frost inside the thermal power plant.

## System check

Before switching on the generator for the first time, a duly qualified technician must perform a check at the central heating plant and update the system log once the check is over.

## Periodic verifications

The generator must be periodically checked by a duly qualified technician (maintenance worker), who should update the system log once the check is over.

## Danger of explosion

Routine and extraordinary maintenance must be entrusted to **professionally qualified personnel** with the purpose of promptly detecting any damage to the generator's pressurised body and the safety and control accessories.

## Danger deriving from the fuel

Sensing the presence of fuel in the thermal power plant, it is appropriate to follow the precautions below to avoid the risk of explosions and fires:

- Do not smoke or cause sparks.
- Do not turn on lights or electrical devices in general (mobile phones).
- Open doors and windows.
- Close the fuel shut-off valve normally placed outside the thermal power plant.
- Disconnect the electrical power supply by using the switch normally placed outside the thermal power plant.

### **Danger of burns**

During normal operation, the generator has hot parts that, upon accidental contact without suitable personal protection, can cause serious burns. Potentially hot parts include:

- Accessories and valves connected to the generator.
- Door and smoke chamber.

### **Danger from fumes**

An incorrect adjustment of the closing door or an insufficient draught in the flue can leave fumes inside the thermal power plant, causing fatal intoxication deriving from carbon monoxide which, by its nature, is colourless and odourless. Therefore, ensure the generator is properly installed and adjusted and the presence of ventilation openings in the thermal power plant are compliant with the regulations in force.

### **Repairs**

Any generator repair must be carried out or authorised by the manufacturer in order to avoid risks to people and property, as well as to prevent **voiding the Warranty Conditions being** . Generator maintenance must be entrusted to competent personnel.

### **Spare parts**

In order to ensure maximum safety and reliability, it is essential that all removable defective accessories and parts are replaced with **Original Spare Parts** supplied by the Manufacturer.

## GENERAL FEATURES

This steel boiler range features 3 gas passes with no flame inversion.

This design minimises the formation of nitrous oxides (NOx) caused by the high temperatures and long flame stay times typical of traditional boiler furnaces.

Furthermore, the BT range boilers have been designed for low temperature operations (return at 35°C). For this reason, a double tube and a special smokebox refractory protection are essential to maintain the high temperature of parts in contact with combustion product, and without condensate production.

The boilers are classified as “high performance” boilers according to the regulations in force due to their extremely high efficiency deriving from optimisation of heat exchange and complete insulation of the exposed surfaces.



*The above picture is only for reference.*

### 3. GENERAL WARNINGS

Each generator is provided with a **manufacture plate** that can be found in the envelope with the boiler documents. The plate lists:

- Serial number or identification code;
- Rated thermal output in kcal/h and in kW;
- Furnace thermal output in kcal/h and in kW;
- Types of fuels that can be used;
- Max operating pressure.

A **manufacture certificate** is also provided which certifies the hydraulic test positive performance.

The installation must be performed in compliance with the regulations in force by **professionally qualified personnel**. The term "professionally qualified personnel" means persons with specific technical skills in the sector of heating system components. Incorrect installation may cause damage to persons, animals or objects for which the manufacturer cannot be held responsible.

**At the first start up**, all regulation and control devices positioned on the control panel should be checked for efficiency.

The **guarantee** shall be valid only upon compliance with the instruction given in this manual.

Our boilers have been built and tested in observance of EEC requirements and, as a consequence, CE-marked. EEC directives are as follows:

- **Directive on Gas** 2009/142/CE (Rif. EN 303)
- **Directive on Output** 92/42/EEC
- **Directive on Electromagnetic Compatibility** 2014/30/UE
- **Directive on Low Voltage** 2014/35/UE

**IMPORTANT:** This boiler has been designed to heat hot water at a temperature less than the boiling temperature at atmospheric pressure and must be connected to a heating plant and/or a domestic hot water plant within the limits of its performance and output.

## 4. TECHNICAL SPECIFICATIONS

### GREENOX.E 10 ÷ 70 BOILER

Characteristics	u.m.	Heat output		Heat input		Efficiency 100% (N.C.V.)	Effic. 100% (stars)	NG max flow rate G20	NG max flow rate G30	NG max flow rate G31	Max flow rate of flues	Max fluid flow	Min. fluid flow	Efficiency at 30% (N.C.V.)
		kW	kcal/h	kW	kcal/h	%	%	Sm <sup>3</sup> /h	kg/h	kg/h	kg/h	kg/h	kg/h	kg/h
	NOTE	Medium Temp. 70°C				Medium Temp. 70°C	(Efficiency Dir. 92/42/CEE)							Medium Temp. 70°C
GREENOX.e 10	(3)	109	94.000	115	98.900	94,78	***	12,17	9,03	8,93	181,33	9400	3760	95,70
GREENOX.e 12	(3)	120	103.000	126	108.360	95,24	***	13,33	9,90	9,79	198,62	10300	4120	95,70
GREENOX.e 15	(3)	150	129.000	157	135.020	95,54	***	16,61	12,33	12,20	247,49	12900	5160	96,05
GREENOX.e 20	(3)	200	172.000	210	180.600	95,24	***	22,22	16,49	16,31	331,08	17200	6880	95,75
GREENOX.e 25	(3)	250	215.000	262	225.320	95,42	***	27,72	20,58	20,35	413,03	21500	8600	95,95
GREENOX.e 30	(3)	300	258.000	315	270.900	95,24	***	33,33	24,74	24,47	496,62	25800	10320	95,73
GREENOX.e 35	(3)	350	301.000	367	315.620	95,37	***	38,84	28,82	28,51	578,72	30100	12040	95,90
GREENOX.e 40	(3)	420	361.000	441	379.260	95,24	-	46,67	34,64	34,26	695,38	36100	14440	95,76
GREENOX.e 47	(3)	470	404.000	493	423.980	95,33	-	52,17	38,72	38,30	777,33	40400	16160	95,80
GREENOX.e 60	(3)	600	516.000	630	541.800	95,24	-	66,67	49,48	48,94	993,38	51600	20640	95,77
GREENOX.e 70	(3)	700	602.000	734	631.240	95,37	-	77,67	57,65	57,02	1157,28	60200	24080	95,85

(3) Door opening reversible

Characteristics	Pressure losses flue gas side	Heat losses through the chimney	Heat losses through the casing	Heat losses with burner off	Flue gas temp. at boiler output and air at 20 deg. C			CO2			Press. losses fluid side	Design Pressure	Capacity	Total weight	Electric supply	Frequency	Insulation class	Electric power	Fuel			
	mbar	%	%	%	°C	°C	°C	%	%	%	mbar	bar	l	kg	Volt ~	Hz	IP	W	Nat. gas	Lpg	Gasoil	Heavy oil
					GAS	GASOIL	HEAVY OIL	GAS	GASOIL	HEAVY OIL	(ΔT=12K)							With electr. contr. (excluded pump and burner)				
GREENOX.e 10	1,2	4,72	0,50	0,10	138	137	137	11,0	13,5	14,0	19	5	296	615	230	50	IP40	20	X	X	X	X
GREENOX.e 12	1,4	4,26	0,50	0,10	127	127	127	11,0	13,5	14,0	23	5	296	615	230	50	IP40	20	X	X	X	X
GREENOX.e 15	2,5	3,96	0,50	0,10	120	120	120	11,0	13,5	14,0	35	5	296	615	230	50	IP40	20	X	X	X	X
GREENOX.e 20	2,6	4,26	0,50	0,10	127	127	127	11,0	13,5	14,0	63	5	296	615	230	50	IP40	20	X	X	X	X
GREENOX.e 25	2,5	4,08	0,50	0,10	122	123	122	11,0	13,5	14,0	34	5	412	735	230	50	IP40	20	X	X	X	X
GREENOX.e 30	3,9	4,26	0,50	0,10	127	127	127	11,0	13,5	14,0	50	5	412	735	230	50	IP40	20	X	X	X	X
GREENOX.e 35	3,9	4,13	0,50	0,10	124	124	124	11,0	13,5	14,0	29	5	505	850	230	50	IP40	20	X	X	X	X
GREENOX.e 40	5,2	4,26	0,50	0,10	127	127	127	11,0	13,5	14,0	42	5	505	850	230	50	IP40	20	X	X	X	X
GREENOX.e 47	4,6	4,17	0,50	0,10	125	125	124	11,0	13,5	14,0	53	5	738	1110	230	50	IP40	20	X	X	X	X
GREENOX.e 60	4,9	4,26	0,50	0,10	127	127	127	11,0	13,5	14,0	35	5	863	1390	230	50	IP40	20	X	X	X	X
GREENOX.e 70	5,6	4,13	0,50	0,10	124	124	124	11,0	13,5	14,0	48	5	863	1390	230	50	IP40	20	X	X	X	X

- N1 Flow
- N2 Return
- N3 Fitting for instruments
- N4 System filling/drainage
- N5 Fitting for safety valves
- N6 Bulb wells
- N7 Boiler condensation drain
- N8 Inspection well

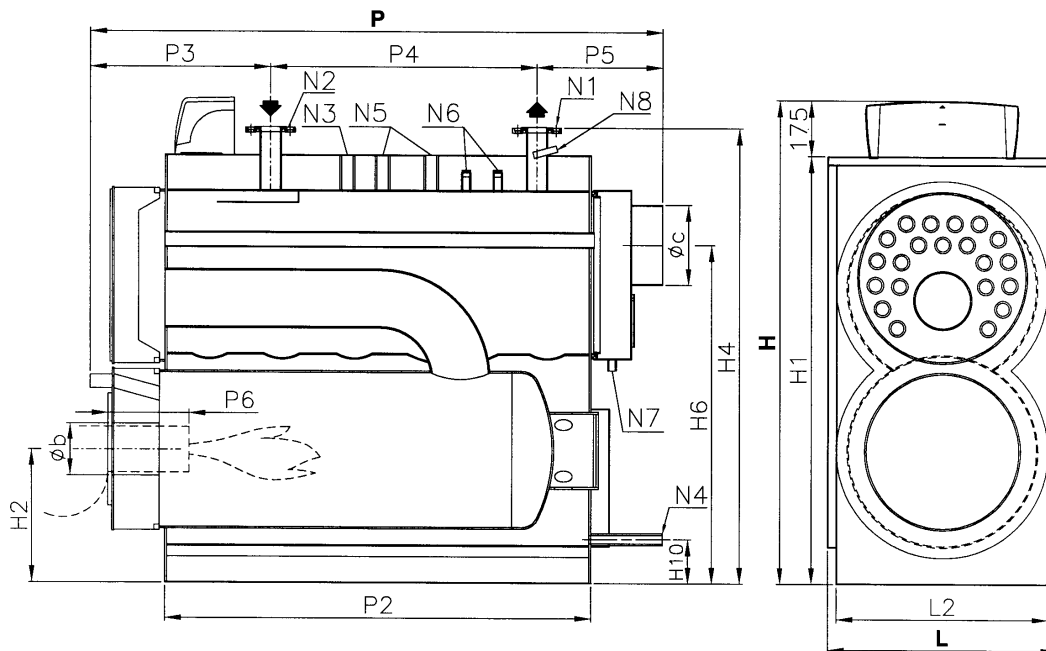

Dimensions	H	H1	H2	H4	H6	H10	L	L2	P	P2	P3	P4	P5	P6	Øb	Øc	N1	N2	N1/N2	N3	N4	N5	N6	N7	N8
	mm	mm	mm	mm	mm	mm	mm	mm	mm	mm	mm	mm	mm	mm	mm	mm	DN/in	DN/in	PN	DN/in	DN/in	DN/in	DN/in	DN/in	DN/in
<b>GREENOx.e 10</b>	<b>1400</b>	1225	374	1277	978	155	<b>715</b>	660	<b>1735</b>	1252	598	740	397	200-250	160	200	50	50	6	1"	1"	1" (1)	1/2"	1/2"	1/2"
<b>GREENOx.e 12</b>	<b>1400</b>	1225	374	1277	978	155	<b>715</b>	660	<b>1735</b>	1252	598	740	397	200-250	160	200	50	50	6	1"	1"	1" (1)	1/2"	1/2"	1/2"
<b>GREENOx.e 15</b>	<b>1400</b>	1225	374	1277	978	155	<b>715</b>	660	<b>1735</b>	1252	598	740	397	200-250	160	200	50	50	6	1"	1"	1" (1)	1/2"	1/2"	1/2"
<b>GREENOx.e 20</b>	<b>1400</b>	1225	374	1277	978	155	<b>715</b>	660	<b>1735</b>	1252	598	740	397	200-250	160	200	50	50	6	1"	1"	1" (1)	1/2"	1/2"	1/2"
<b>GREENOx.e 25</b>	<b>1520</b>	1345	410	1397	1082	155	<b>755</b>	700	<b>1895</b>	1412	598	900	397	200-250	170	250	65	65	6	1"	1"	1" (1)	1/2"	1/2"	1/2"
<b>GREENOx.e 30</b>	<b>1520</b>	1345	410	1397	1082	155	<b>755</b>	700	<b>1895</b>	1412	598	900	397	200-250	170	250	65	65	6	1"	1"	1" (1)	1/2"	1/2"	1/2"
<b>GREENOx.e 35</b>	<b>1675</b>	1500	460	1555	1210	155	<b>800</b>	745	<b>1948</b>	1462	651	900	397	200-250	225	250	80	80	6	1"1/4	1"	1"1/4 (1)	1/2"	1/2"	1/2"
<b>GREENOx.e 40</b>	<b>1675</b>	1500	460	1555	1210	155	<b>800</b>	745	<b>1948</b>	1462	651	900	397	200-250	225	250	80	80	6	1"1/4	1"	1"1/4 (1)	1/2"	1/2"	1/2"
<b>GREENOx.e 47</b>	<b>1805</b>	1630	495	1685	1340	155	<b>875</b>	820	<b>2227</b>	1744	698	1075	454	200-250	225	250	80	80	6	1"1/4	1"	1"1/4 (1)	1/2"	1/2"	1/2"
<b>GREENOx.e 60</b>	<b>1925</b>	1750	520	1802	1422	155	<b>945</b>	890	<b>2228</b>	1746	699	1100	429	200-250	225	250	100	100	6	1"1/4	1"	1"1/4	1/2"	1/2"	1/2"
<b>GREENOx.e 70</b>	<b>1925</b>	1750	520	1802	1422	155	<b>945</b>	890	<b>2228</b>	1746	699	1100	429	200-250	225	250	100	100	6	1"1/4	1"	1"1/4	1/2"	1/2"	1/2"

<sup>(1)</sup> One fitting only



# GREENOX.E 80 ÷ 300 BOILER

Characteristics		Heat output		Heat input		Efficiency 100% (N.C.V.)	NG max flow rate G20	NG max flow rate G30	NG max flow rate G31	Max flow rate of flues	Max fluid flow	Min. fluid flow	Efficiency at 30%
		kW	kcal/h	kW	kcal/h	%	Stm <sup>3</sup> /h	kg/h	kg/h	kg/h	kg/h	kg/h	%
	NOTE	Medium Temp. 70°C				Medium Temp. 70°C							Medium Temp. 70°C
GREENOX.e 80	(3)	800	688.000	839	721.540	95,35	88,78	65,89	65,18	1322,82	68800	27520	95,88
GREENOX.e 90	(3)	900	774.000	944	811.840	95,34	99,89	74,14	73,34	1488,36	77400	30960	95,92
GREENOX.e 100		1000	860.000	1050	903.000	95,24	111,11	82,47	81,57	1655,54	86000	34400	95,76
GREENOX.e 120		1200	1.032.000	1259	1.082.740	95,31	133,23	98,88	97,81	1985,13	103200	41280	95,83
GREENOX.e 140		1400	1.204.000	1469	1.263.340	95,30	155,45	115,37	114,12	2316,21	120400	48160	95,84
GREENOX.e 170		1700	1.462.000	1784	1.534.240	95,29	188,78	140,11	138,59	2812,82	146200	58480	95,79
GREENOX.e 200		2000	1.720.000	2099	1.805.140	95,28	222,12	164,85	163,07	3309,59	172000	68800	95,79
GREENOX.e 230		2300	1.978.000	2415	2.076.900	95,24	255,56	189,67	187,62	3807,84	197800	79120	95,77
GREENOX.e 260		2600	2.236.000	2731	2.348.660	95,20	288,99	214,49	212,16	4305,95	223600	89440	95,80
GREENOX.e 300		3000	2.580.000	3150	2.709.000	95,24	333,33	247,40	244,72	4966,62	258000	103200	95,80

(3) Door opening reversible

Characteristics	Pressure losses flue gas side	Heat losses through the chimney	Heat losses through the casing	Heat losses with burner off	Flue gas temp. at boiler output and air at 20 deg. C			CO2			Press. losses fluid side	Design Pressure	Capacity	Total weight	Electric supply	Frequency	Insulation class	Electric power	Fuel			
	mbar	%	%	%	°C	°C	°C	%	%	%	mbar	bar	l	kg	Volt ~	Hz	IP	W				
					GAS	GASOIL	HEAVY OIL	GAS	GASOIL	HEAVY OIL	(ΔT=12K)							With electr. contr. (excluded pump and	Nat. Gas	Lpg	Gasoil	Heavy oil
GREENOX.e 80	2,8	4,15	0,50	0,10	124	124	124	11,0	13,5	14,0	63	5	1200	1970	230	50	IP40	20	X	X	X	X
GREENOX.e 90	3,5	4,16	0,50	0,10	124	124	124	11,0	13,5	14,0	80	5	1200	1970	230	50	IP40	20	X	X	X	X
GREENOX.e 100	2,6	4,26	0,50	0,10	127	127	127	11,0	13,5	14,0	40	5	1365	2760	230	50	IP40	20	X	X	X	X
GREENOX.e 120	4,0	4,19	0,50	0,10	125	125	125	11,0	13,5	14,0	58	5	1365	2760	230	50	IP40	20	X	X	X	X
GREENOX.e 140	5,5	4,20	0,50	0,10	125	125	125	11,0	13,5	14,0	38	5	1570	2995	230	50	IP40	20	X	X	X	X
GREENOX.e 170	5,0	4,21	0,50	0,10	126	126	125	11,0	13,5	14,0	56	5	2300	4300	230	50	IP40	20	X	X	X	X
GREENOX.e 200	7,0	4,22	0,50	0,10	126	126	126	11,0	13,5	14,0	78	5	2800	4850	230	50	IP40	20	X	X	X	X
GREENOX.e 230	9,0	4,26	0,50	0,10	127	127	127	11,0	13,5	14,0	103	5	2800	4850	230	50	IP40	20	X	X	X	X
GREENOX.e 260	9,0	4,30	0,50	0,10	128	128	127	11,0	13,5	14,0	42	5	3300	5950	230	50	IP40	20	X	X	X	X
GREENOX.e 300	12,0	4,26	0,50	0,10	127	127	127	11,0	13,5	14,0	55	5	3300	5950	230	50	IP40	20	X	X	X	X

- N1 Flow
- N2 Return
- N3 Fitting for instruments
- N4 System filling/drainage
- N5 Fitting for safety valves
- N6 Bulb wells
- N7 Boiler condensation drain
- N8 Inspection well

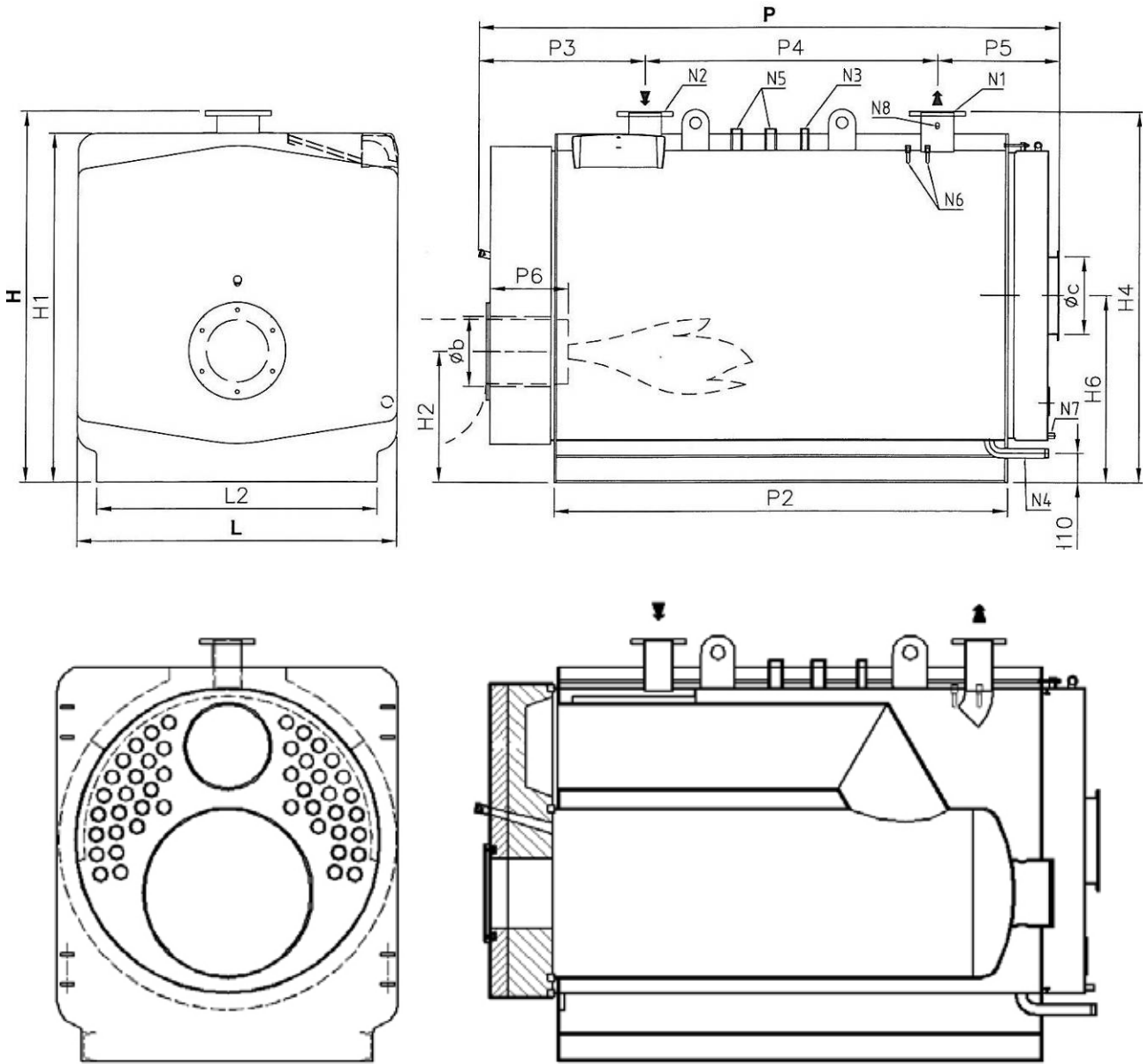

Dimensions	H	H1	H2	H4	H6	H10	L	L2	P	P2	P3	P4	P5	P6	Øb	Øc	N1	N2	N1/N2	N3	N4	N5	N6	N7	N8
	mm	mm	mm	mm	mm	mm	mm	mm	mm	mm	mm	mm	mm	mm	mm	mm	DN/in	DN/in	PN	DN/in	DN/in	DN/in	DN/in	DN/in	DN/in
<b>GREENOx.e 80</b>	1712	1600	682	1712	895	210	1380	1180	2535	1970	748	1300	487	300-350	280	350	100	100	16	1"	1"1/4	1"1/2	1/2"	1/2"	1/2"
<b>GREENOx.e 90</b>	1712	1600	682	1712	895	210	1380	1180	2535	1970	748	1300	487	300-350	280	350	100	100	16	1"	1"1/4	1"1/2	1/2"	1/2"	1/2"
<b>GREENOx.e 100</b>	1764	1650	671	1764	890	150	1490	1290	2589	1972	800	1300	489	360-410	280	400	125	125	16	1"	1"1/4	1"1/2	1/2"	1/2"	1/2"
<b>GREENOx.e 120</b>	1764	1650	671	1764	890	150	1490	1290	2589	1972	800	1300	489	360-410	320	400	125	125	16	1"	1"1/4	1"1/2	1/2"	1/2"	1/2"
<b>GREENOx.e 140</b>	1764	1650	671	1764	890	150	1490	1290	2899	2282	850	1500	499	360-410	320	400	150	150	16	1"	1"1/4	1"1/2	1/2"	1/2"	1/2"
<b>GREENOx.e 170</b>	2065	1950	800	2065	1040	150	1800	1600	2966	2324	875	1500	591	360-410	360	400	150	150	16	1"	1"1/4	1"1/2	1/2"	1/2"	1/2"
<b>GREENOx.e 200</b>	2065	1950	800	2065	1040	150	1800	1600	3466	2824	875	2000	591	360-410	360	400	150	150	16	1"1/2	1"1/4	2"	1/2"	1/2"	1/2"
<b>GREENOx.e 230</b>	2065	1950	800	2065	1040	150	1800	1600	3466	2824	875	2000	591	360-410	360	400	150	150	16	1"1/2	1"1/4	2"	1/2"	1/2"	1/2"
<b>GREENOx.e 260</b>	2065	1950	800	2065	1040	150	1800	1600	3935	3324	875	2500	560	360-410	360	500	200	200	16	1"1/2	1"1/4	2"	1/2"	1/2"	1/2"
<b>GREENOx.e 300</b>	2065	1950	800	2065	1040	150	1800	1600	3935	3324	875	2500	560	360-410	360	500	200	200	16	1"1/2	1"1/4	2"	1/2"	1/2"	1/2"

# GREENOX BT COND BOILER

- N1 Boiler flow
- N2 Boiler return
- N3 Fitting for instruments
- N4 Boiler drain
- N5 Fitting for safety valves
- N6 Bulbs wells
- N8 Inspection well
- N11 Condenser return temperature control
- N12 Condenser flow
- N13 Condenser return
- N14 Condenser condensation drain
- N16 Condenser drain
- N17 Air vent fitting
- N27 Condenser flow temperature control

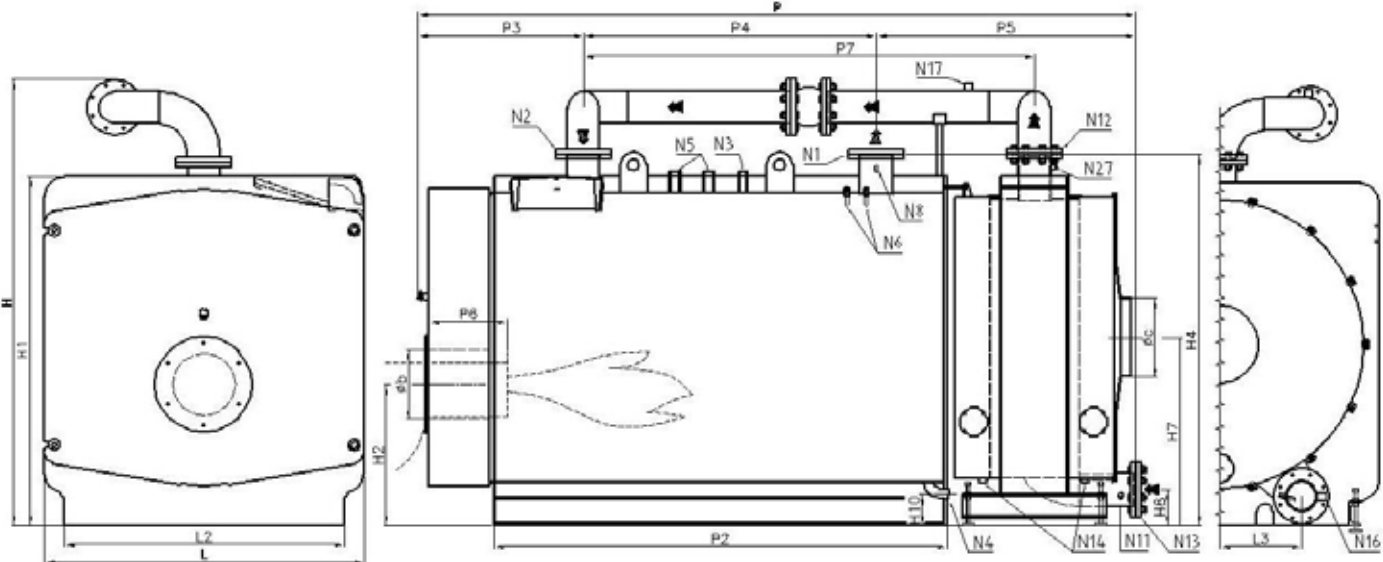

Characteristics	Heat output				Heat input		Efficiency 100% (N.C.V.)		NG max flow rate G20	NG max flow rate G30	NG max flow rate G31	Max flow rate of flues	Max fluid flow	Min. fluid flow
	kW		kcal/h		kW		%		Sm <sup>3</sup> /h	kg/h	kg/h			
	Medium Temp. 70°C		Temp. flow/return 50/30°C		Temp. flow/return 50/30°C		Medium Temp. 70°C							
<b>GREENOX BT COND 100</b>	914	786.400	<b>1000</b>	860.000	930	800.000	98,30	107,50	98,44	73,06	72,27	1466,76	86000	34400
<b>GREENOX BT COND 120</b>	1097	943.680	<b>1200</b>	1.032.000	1116	960.000	98,30	107,50	118,12	87,67	86,72	1759,99	103200	41280
<b>GREENOX BT COND 140</b>	1280	1.100.960	<b>1400</b>	1.204.000	1302	1.120.000	98,30	107,50	137,81	102,28	101,17	2053,37	120400	48160
<b>GREENOX BT COND 160</b>	1463	1.258.240	<b>1600</b>	1.376.000	1488	1.280.000	98,30	107,50	157,50	116,89	115,63	2346,75	137600	55040
<b>GREENOX BT COND 180</b>	1646	1.415.520	<b>1800</b>	1.548.000	1674	1.440.000	98,30	107,50	177,19	131,51	130,08	2640,13	154800	61920
<b>GREENOX BT COND 200</b>	1829	1.572.800	<b>2000</b>	1.720.000	1860	1.600.000	98,30	107,50	196,87	146,12	144,53	2933,36	172000	68800
<b>GREENOX BT COND 230</b>	2103	1.808.720	<b>2300</b>	1.978.000	2140	1.840.000	98,30	107,50	226,41	168,04	166,21	3373,51	197800	79120
<b>GREENOX BT COND 260</b>	2377	2.044.640	<b>2600</b>	2.236.000	2419	2.080.000	98,30	107,50	255,94	189,95	187,90	3813,51	223600	89440
<b>GREENOX BT COND 300</b>	2743	2.359.200	<b>3000</b>	2.580.000	2791	2.400.000	98,30	107,50	295,31	219,18	216,80	4400,12	258000	103200

Characteristics	Pressure losses flue gas side	Heat losses through the chimney	Heat losses through the casing	Heat losses with burner off	Flue gas temp. at boiler output and air at 20 deg. C	CO2	Condense production	Press. losses fluid side	Design Pressure	Capacity	Total capacity	Total weight	Electric supply	Frequency	Insulation class	Electric power	Fuel			
																	With elect. contr. (excluded pump and burner)	Nat. gas	Lpg	Gasoil
<b>GREENOX BT COND 100</b>	3,5	1,50	0,50	0,10	50	10,5	233,3	32	5	1800	1800	3100	230	50	IP40	20	X	X	-	-
<b>GREENOX BT COND 120</b>	5,0	1,50	0,50	0,10	50	10,5	279,9	47	5	1800	1800	3100	230	50	IP40	20	X	X	-	-
<b>GREENOX BT COND 140</b>	5,4	1,50	0,50	0,10	50	10,5	326,6	64	5	2000	2000	3850	230	50	IP40	20	X	X	-	-
<b>GREENOX BT COND 160</b>	7,0	1,50	0,50	0,10	50	10,5	373,3	83	5	2000	2000	3850	230	50	IP40	20	X	X	-	-
<b>GREENOX BT COND 180</b>	5,0	1,50	0,50	0,10	50	10,5	419,9	105	5	2957	2957	6080	230	50	IP40	20	X	X	-	-
<b>GREENOX BT COND 200</b>	6,0	1,50	0,50	0,10	50	10,5	466,6	130	5	2957	2957	6080	230	50	IP40	20	X	X	-	-
<b>GREENOX BT COND 230</b>	7,5	1,50	0,50	0,10	50	10,5	536,6	172	5	2957	2957	6080	230	50	IP40	20	X	X	-	-
<b>GREENOX BT COND 260</b>	7,0	1,50	0,50	0,10	50	10,5	606,6	69	5	3507	3507	6750	230	50	IP40	20	X	X	-	-
<b>GREENOX BT COND 300</b>	9,0	1,50	0,50	0,10	50	10,5	699,9	93	5	3507	3507	6750	230	50	IP40	20	X	X	-	-

Dimensions	H	H1	H2	H4	H7	H8	H10	L	L2	P	P2	P3	P4	P5	P6	Øb	Øc	N1	N2	N1/N2	N4	N8	N11	N12	N13	N14	N16	N17	N27
	mm	mm	mm	mm	mm	mm	mm	mm	mm	mm	mm	mm	mm	mm	mm	mm	mm	DN/in	DN/in	PN	DN/in	DN/in	DN/in	DN/in/mm	DN/in	in	in	in	in
<b>GREENOX BT COND 100</b>	2089	1950	800	2064	1040	206	155	1490	1600	3330	1474	850	2000	480	360-410	360	400	150	150	16	1"1/4	1/2"	1/2"	150	150	1"	1"	1"	1/2"
<b>GREENOX BT COND 120</b>	2089	1950	800	2064	1040	206	155	1490	1600	3330	1474	850	2000	480	360-410	360	400	150	150	16	1"1/4	1/2"	1/2"	150	150	1"	1"	1"	1/2"
<b>GREENOX BT COND 140</b>	2121	1950	800	2064	1040	206	155	1490	1600	3797	1941	850	2000	947	360-410	360	400	150	150	16	1"1/4	1/2"	1/2"	150	150	1"	1"	1"	1/2"
<b>GREENOX BT COND 160</b>	2121	1950	800	2064	1040	206	155	1490	1600	3797	1941	850	2000	947	360-410	360	400	150	150	16	1"1/4	1/2"	1/2"	150	150	1"	1"	1"	1/2"
<b>GREENOX BT COND 180</b>	2448	1950	800	2064	1040	206	155	1800	1600	4180	2824	850	2000	1330	360-410	360	400	150	150	16	1"1/4	1/2"	1/2"	150	150	1"	1"	1"	1/2"
<b>GREENOX BT COND 200</b>	2448	1950	800	2064	1040	206	155	1800	1600	4180	2824	850	2000	1330	360-410	360	400	150	150	16	1"1/4	1/2"	1/2"	150	150	1"	1"	1"	1/2"
<b>GREENOX BT COND 230</b>	2448	1950	800	2064	1040	206	155	1800	1600	4180	2824	850	2000	1330	360-410	360	400	150	150	16	1"1/4	1/2"	1/2"	150	150	1"	1"	1"	1/2"
<b>GREENOX BT COND 260</b>	2554	1950	800	2064	1040	206	155	1800	1600	4680	3324	880	2500	1300	360-410	360	400	200	200	16	1"1/4	1/2"	1/2"	200	200	1"	1"	1"	1/2"
<b>GREENOX BT COND 300</b>	2554	1950	800	2064	1040	206	155	1800	1600	4680	3324	880	2500	1300	360-410	360	400	200	200	16	1"1/4	1/2"	1/2"	200	200	1"	1"	1"	1/2"

## 5. INSTALLATION

Before **connecting** the boiler, perform the following operations:

- Thoroughly clean all the **system pipes** in order to remove any foreign matter that could affect correct operation of the boiler;
- Check that the flue has an adequate draught, that there is no narrowing of passages and that it is free from debris; also check that other appliances do not discharge into the flue (unless designed to serve several utilities). See the regulations in force.

### THERMAL PLANT

#### ROOM BOILER

**Current regulations must always be observed.**

Premises in which boilers will be installed should be sufficiently ventilated and permit access for ordinary and extraordinary maintenance operations.

#### FLUE



#### **IMPORTANTE**

The smokestack must be dimensioned as to applicable regulations.

## HYDRAULIC CONNECTION

### SEALED Hot water heating system with expansion vessel

The generator must be provided with:

- a - 1 safety valve
- 2 safety valves if output is ( $\geq 500.000$  kcal/h)
- b - Expansion vessel
- c - Regulation thermostats
- d - 1st safety thermostat
- e - 2nd safety thermostat
- f - Cut-off pressure switch
- g - Well for control thermometer
- h - Pressure gauge with flange for control pressure gauge
- i - Heat discharge valve or fuel on-off valve

- N1 - Flow
- N2 - Return
- N3 - Instrument fitting
- N4 - Lower fitting:
  - N4b expansion vessel fitting
  - N4c Filling/drain
- N5 - Safety valve fitting ( $\geq 500.000$  kcal/h: n. 2 valves)
- N6 - Bulb wells (thermometer, pump consent thermostat, regulation thermostat, safety thermostat)
- N7 - Condensation recollection fitting

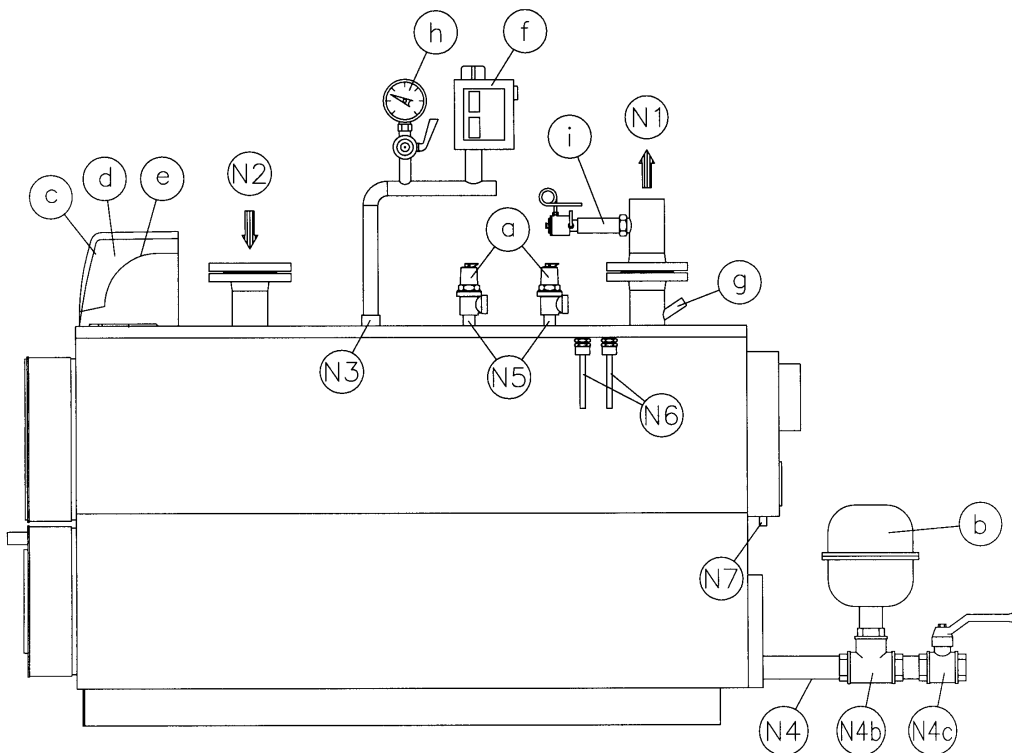

Ensure that the hydraulic pressure measured after the reduction valve on the supply pipe does not exceed the operating **pressure specified on the rating plate of the component** (boiler, heater etc.).

- As the water contained in the heating system increases in pressure during operation, ensure that its maximum value does not exceed the maximum hydraulic pressure specified on the component rating plate.
- Ensure that the safety valve outlets of the boiler and hot water tank, if any, have been connected to an exhaust funnel in order to prevent the valves from **flooding the room** if they open.
- Ensure that the pipes of the water and heating system **are not used as an earth connection** for the electrical system as this can seriously and very rapidly damage the pipes, boiler, heater and radiators.
- Once the heating system has been filled, you are advised to close the supply cock and keep it closed so that **any leaks from the system** will be identified by a drop in hydraulic pressure indicated on the system pressure gauge.

## ELECTRICAL CONNECTION

Electrical systems of thermal plants designed only for heating purposes **must comply with numerous legal regulations which apply in general as well as specifically to each application or fuel type.**

## OPTIONAL CONTROL PANEL

The control panel (optional) with the boilers is made of IP40 protection plastic material, and houses the regulation and safety instruments:

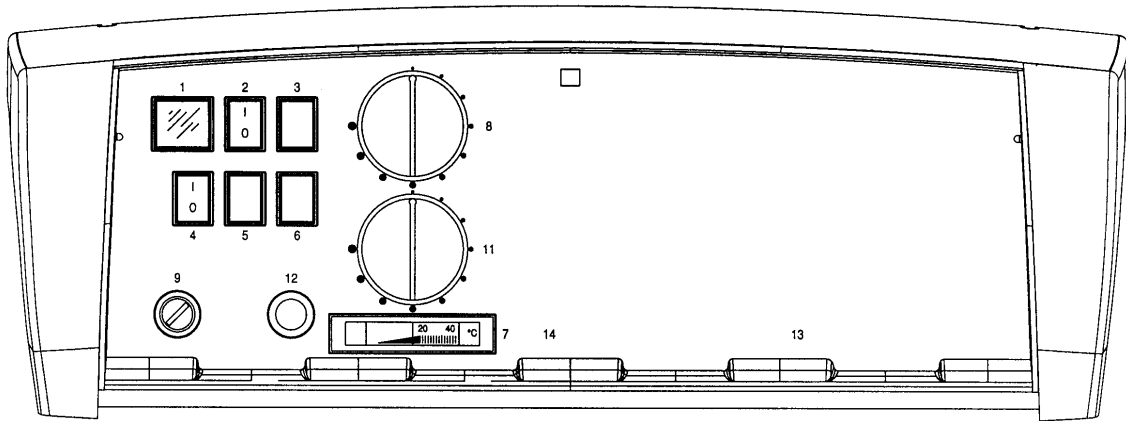

### KEY

- 1 NET WARNING LIGHT
- 2 1<sup>st</sup> BURNER SWITCH
- 4 CIRCULATOR SWITCH
- 7 BOILER THERMOMETER
- 8 1<sup>st</sup> ADJUSTMENT THERMOMETER
- 9 1<sup>st</sup> SAFETY THERMOSTAT
- 11 2<sup>nd</sup> ADJUSTMENT THERMOSTAT

The upper part of the control panel can be rotated to gain access to the terminal board and uncoil the thermostat and thermometer capillaries. A copy of the wiring diagram is contained inside the control panel cover.

The **regulation thermostats** have an operating range from 60° to 100° and can be set by the user by means of the front knob.

**Safety thermostats** has a fixed setting of 110°C and can be manually reset in accordance by law.

**Circulator consent thermostat** located inside the panel can be adjusted from 0°C to 90°C using a tool and is factory-set at 50°C, while its differential deviation is 6°C. Thanks to this thermostat, the circulator is inactive when the temperature is below 50°C to avoid dangerous exhaust condensation.

For correct installation, refer to the boiler casing assembly instructions.

### WIRING DIAGRAM

*Refer to the diagram supplied with the specific switchboard.*

## INSTALLATION OF GREENOX.E 80 ÷ 300 BOILER CONTROL PANEL

*NOTE: the control panel picture is purely indicative as it may vary according to the type of panel installed.*

- a. Choose the side on which to install the control panel (RH or LH), remove the covers (1) and push in the pre-cut opening (2).
- b. Pick up the kit of the arm complete with bracket (3).
- c. Open the control panel (4) and cut the preset window on the rear side.
- d. Pass the bulbs (5) of thermostats and thermometer through the window and screw them in the square pipe of the bracket and slide them in the protective tube through top openings until they reach the wells (6). Lock them using the special locking springs.
- e. Connect the cables of burner (7) to the control panel using a protective sheath and lock them with the cable glands (8).
- f. Secure the control panel to the bracket (3) using the kit supplied.
- g. Use the two screws (9) and fasten the arm-control panel group to the top section of the boiler.
- h. Assemble the covers (1).

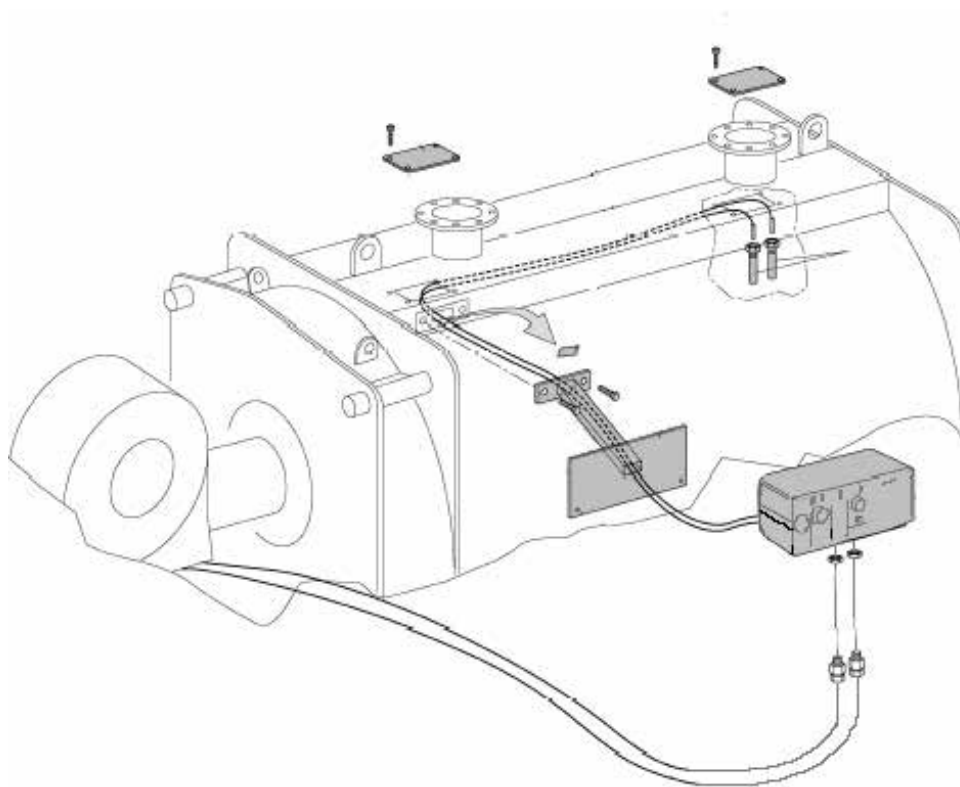

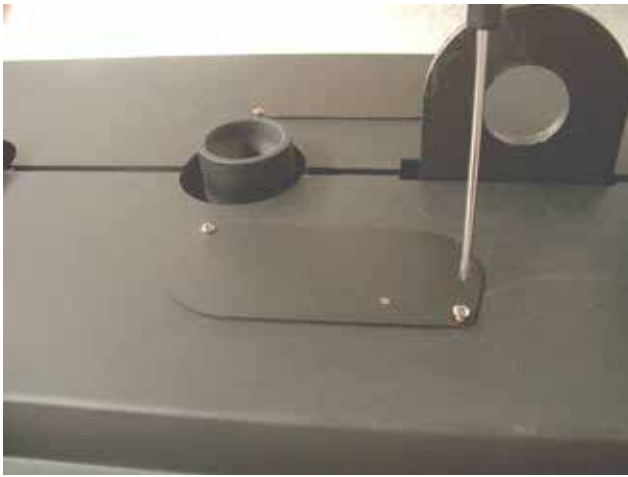

The bracket provided, which is equipped with a 2-hole shaped plate, enables the user to mount the panels with two inclinations, and hence to choose the position he/she prefers (see figures).

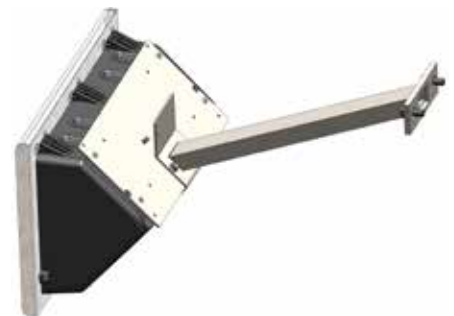



## DOOR

### DOOR OPENING

The door is adjusted in the factory with **standard opening to the left (s)** and with **hinges on the right (d)**.

**CAUTION: it is dangerous to unscrew the ring nuts (8d) on the side of the hinges to avoid causing the door to detach, with possible serious damage to people and property.**

### DOOR OPENING REVERSAL (to the right)

*Only for models listed in the Technical Data table*

Proceed as follows to reverse the opening direction of the door:

#### **Door with ferrules perforated on both sides**

1. **Screw the left perforated ferrules (8s)** so that the door seal gasket is pressed in the same way as the right part. Bring the conical washers (10s) of the left tie-rods close to the mechanical tubes (9s) of the door and tighten the nuts (7s) using a suitable wrench.
2. On the right opening side, loosen the nuts (7d) and free the conical washers (10d) from the mechanical tubes (9d) of the door.

#### **Door with wrench ferrules, hinge side**

**IMPORTANT NOTE: In models equipped with wrench-adjustable ferrules (8d), these must always be mounted on the hinges to prevent the door from being accidentally opened through the lever (12).**

In this case, proceed as follows:

3. Proceed as indicated in point 1.
4. Cross-change the wrench ferrule of a hinge (8d) with the opposite perforated ferrule (8s), after loosening the locking nuts on the tie rods and freeing the conical washers.
5. On the left hinge side, fasten the conical washer (9s) onto the door using the nut (10s).
6. Proceed with the other two ferrules following the procedure described in points 4 and 5.

**CAUTION: When cross-changing ferrules, always make sure that the other two ferrules are fastened, so that they hold the door.**

7. Check the correct adjustment of the tie-rods and hinges ensuring that, during closure, the seal gasket is **evenly pressed in the centre on the whole circumference** (see figure).

If necessary, adjust as described in the next par.

## DOOR ADJUSTMENT (opening on the right)

### Vertical adjustment

1. With the door ajar, loosen the counter-nuts (5s) of the hinge units.
2. Act on the adjustment nuts (4s) to lift or lower the door by centring the gasket on the stop plate (see figure), then block the counter-nuts (5s).
3. Close the door and centre the tie-rod (1d) on the mechanical tube (9d), proceeding as in point 2.

### Horizontal adjustment

Close the door using the lever and check that there is equal distance on both sides, between the stop plate and the band. Otherwise, proceed as follows:

1. With the door ajar, loosen the locking nuts (7s) of the hinge units.
2. Act on the ferrule (8s) to adjust the distance depth-wise.
3. Screw the nuts (7s) and block the conical washers on the mechanical tubes.

Check the proper adjustment in depth ensuring that the door, manually pushed up to the stop plate, naturally returns remaining ajar. This is to ensure the hinge side fume seal.

**For any problems related to the reversal and adjustment of the door, we recommend contacting our local Authorised Technical Assistance Centre.**

**IMPORTANT: Incorrect door adjustment with consequent damage to people and property voids the warranty conditions.**

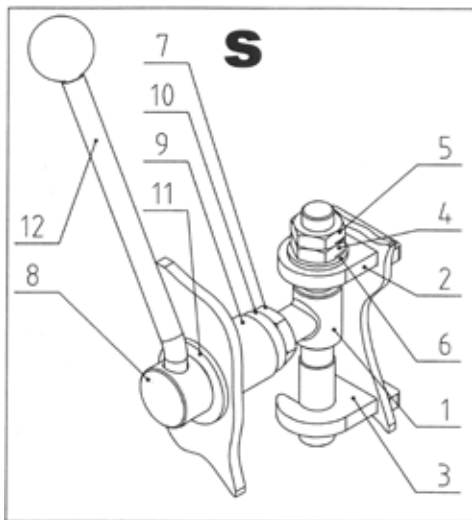

OPENING UNIT

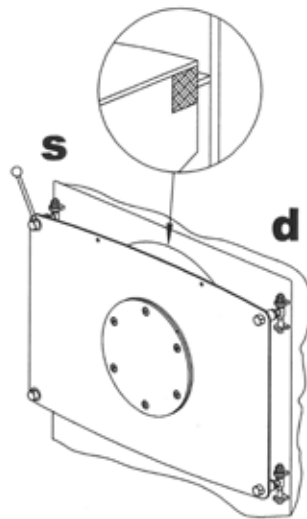

HINGE UNIT

#### KEY

- |                                  |                                       |
|----------------------------------|---------------------------------------|
| 1. Tierrod with pin              | 8. Perforated ferrule for opening (s) |
| 2. Upper bracket                 | Wrench ferrule for hinge (d)          |
| 3. Lower bracket                 | 9. Door mechanical tube               |
| 4. Vertical adjustment nut       | 10. Conical centring washer           |
| 5. Locking counter nut           | 11. Opening lever washer              |
| 6. Vertical tie-rod plain washer | 12. Opening lever                     |
| 7. Horizontal locking nut        |                                       |

## BURNER CONNECTION

Before installation you are advised to thoroughly clean the inside of all the fuel supply system pipes in order to remove any foreign matter that could affect correct operation of the boiler. See technical specification tables and check the max pressure value inside the furnace. The value found on the table may also increase by 20% if heavy oil is used instead of gas or light oil; furthermore the following checks should also be carried out:

- Check the internal and external seal of the fuel supply system;
- Regulate the fuel flow according to the power required by the boiler;
- Check that the boiler is fired by the correct type of fuel;
- Check that the fuel supply pressure is within the values specified on the burner rating plate;
- Check that the fuel supply system is sized for the maximum flow rate necessary for the boiler and that it is provided with all control and safety devices provided for by the regulations referred to above;

In particular, when using gas:

- Check that the supply pipe and the gas ramp comply with the regulations in force;
- Check that all the gas connections are sealed;
- Check that the boiler room vents are of sufficient size to ensure the air flow dictated by the regulations referred to above and that they are in any case sufficient to obtain perfect combustion.
- Check that the gas pipes are not used as earth connections for electrical appliances.

If the boiler is not going to be used for some time, close the fuel supply cock or cocks.

**IMPORTANT: check that the gap between the burner draught tube and the mounting plate are properly filled with thermoinsulating material.**

The thermoinsulating strip provided with the boiler must be wrapped around the mouthpiece for at least an entire circumference of the flame radiation to protect the flange of the burner. Note that the ceramic insulation is necessary to fill the gap until the insulation inside surface of the door.

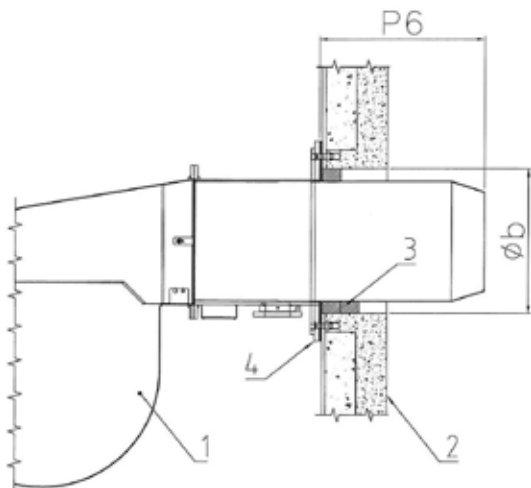

*The above picture is only for reference.*

KEY:

- Burner
- Manhole
- Thermoinsulating material
- Flange

All details on the draught tube length (**P6**), the diameter of the burner hole (**Øb**) and the pressurization are included in the par. Technical Specifications.

**ATTENTION: when using oil or bio-gas for operation, the door must have cement insulation and special tie rods. Any alterations and/or lack of communication during the selling phase shall nullify the warranty conditions.**

**GREENOX BT COND:**

**ATTENTION: The boiler is designed for use with NATURAL GAS and LPG. The use of other fuels will void the boiler warranty.**

## 6. ASSEMBLY

### BOILER CASINGS AND CONTROL PANEL

1) Wrap the fibreglass around the boiler body and use the supplied strap to secure it (see fig.).

DIAGRAM OF PLASTIC STRAP LOCKING  
TO SECURE THE FIBREGLASS  
TO THE BOILER SHELL

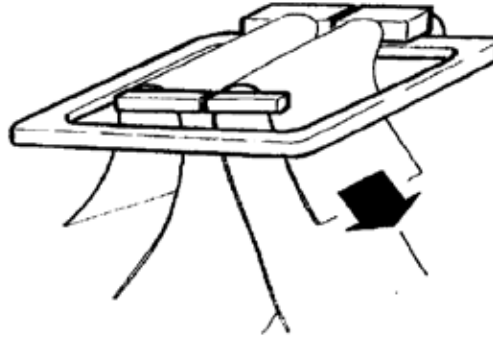

2) Prepare the staves by inserting the four stoppers, as shown in the figure.

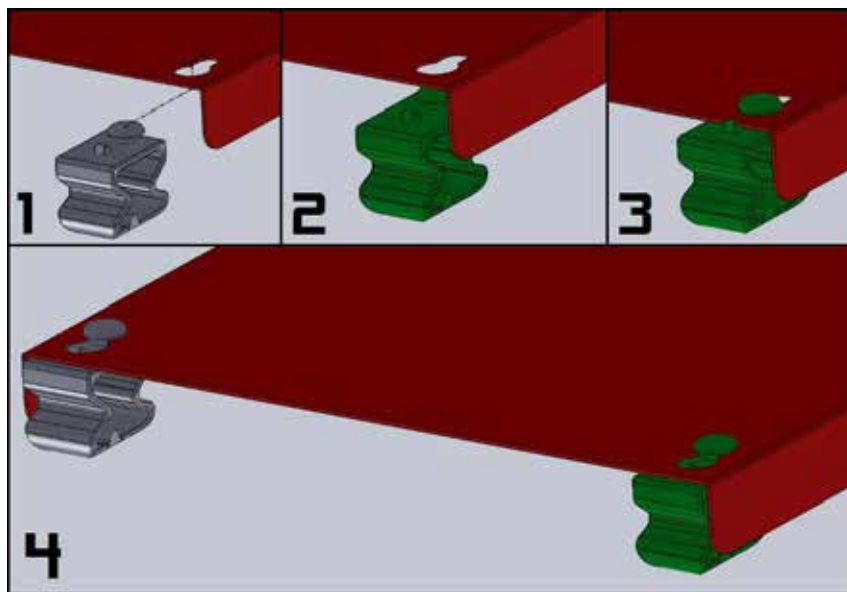

3) Fasten the uprights and the beams to the plates by means of appropriate screws and nuts.

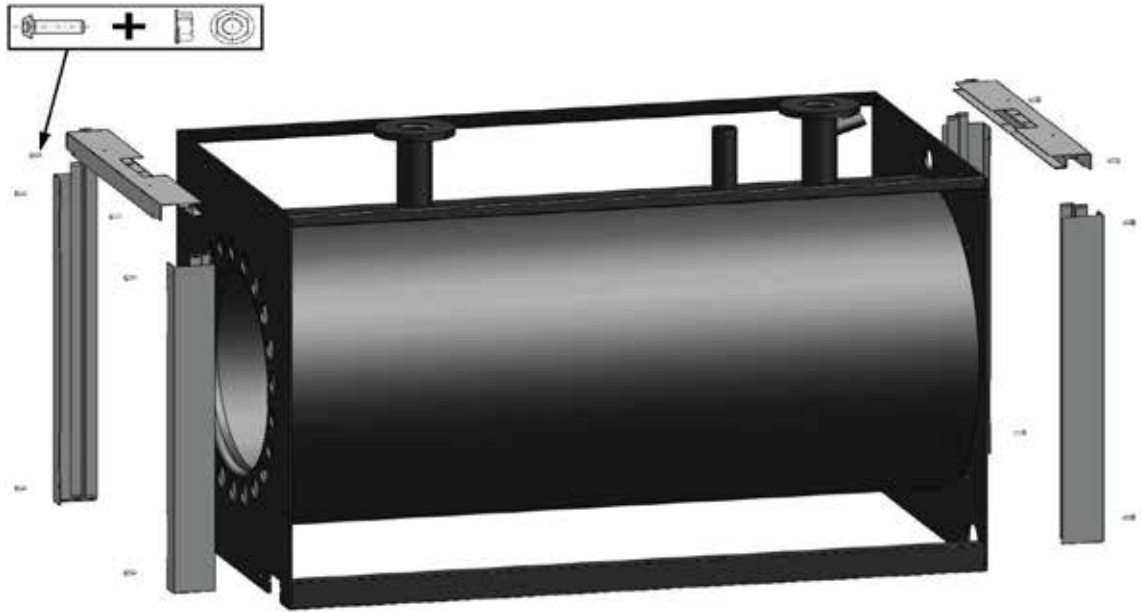

NOTE: the beam shown in the figure, if supplied in the package, must be placed between the two tube panels in order to support the staves.

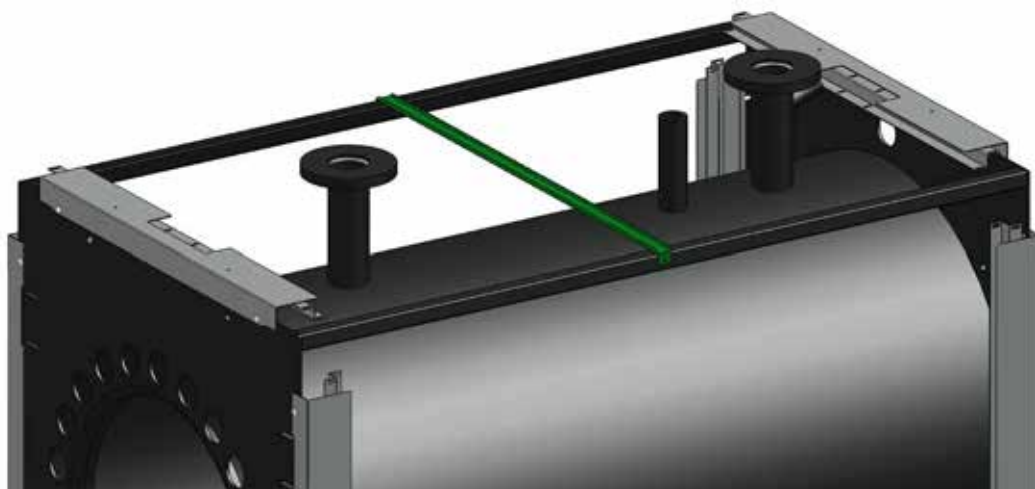

4) Insert the staves, with the previously installed stoppers, between the uprights and the beams, as shown in the figure.  
**PLEASE NOTE: do not cover the upper corner on the manhole side; this is required for the subsequent installation of the control panel and its bulbs.**

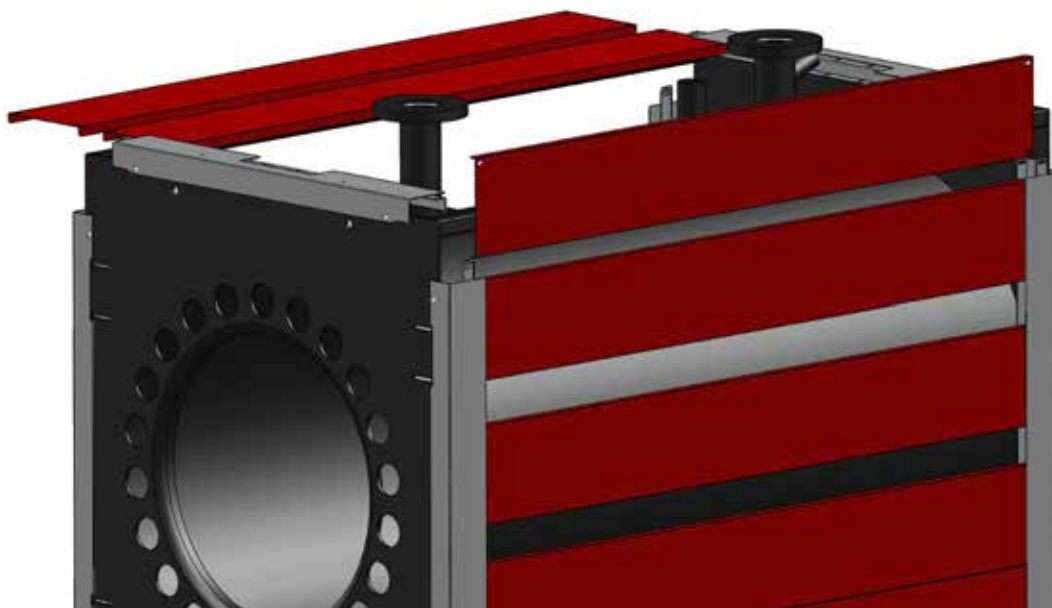

5) After inserting the lags and fastening the relevant central masks (1), install the closing profiles (2) using the self-tapping screws, on the side opposite the manholes.

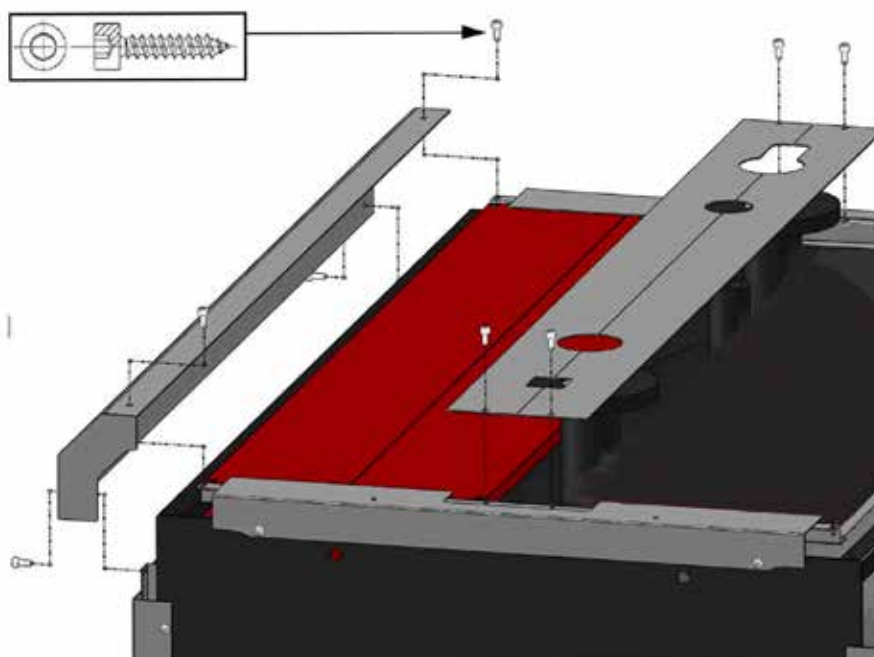

## CONTROL PANEL INSTALLATION

*NOTE: the control panel picture is purely indicative as it may vary according to the type of panel installed.*

### TOP INSTALLATION

- 6) Install the control panel support (3) included in the kit on the front beam of the boiler.
- 7) Place the control panel (4) onto the support (3) and insert the boiler adjustment thermostats capillary tubes, the safety thermostat capillary tubes, the circulator consent thermostat capillary tubes and the boiler thermometer capillary tubes through the relevant openings, until the bulb-holding manholes (5) on the shell have been reached.
- 8) Fasten the control panel onto the support using the screws provided.

### SIDE INSTALLATION

- 6) The control panel can be mounted either on the right or left after mounting the panel support stave (6)
- 7) Place the control panel in the vicinity of the stave (6) and pass the capillaries through the relevant openings, until the bulb-holding manholes (5) on the shell have been reached.
- 8) Fasten the control panel onto the stave using the screws provided.

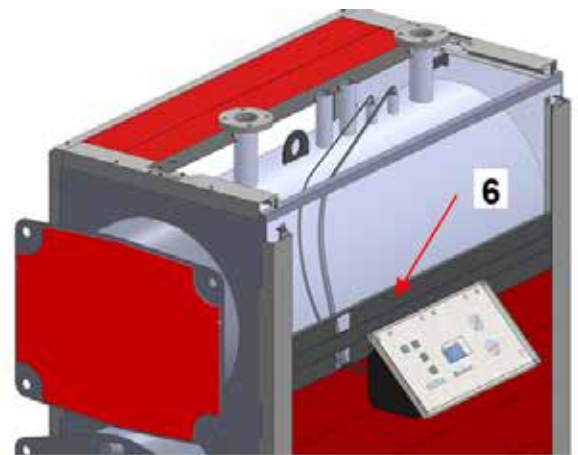
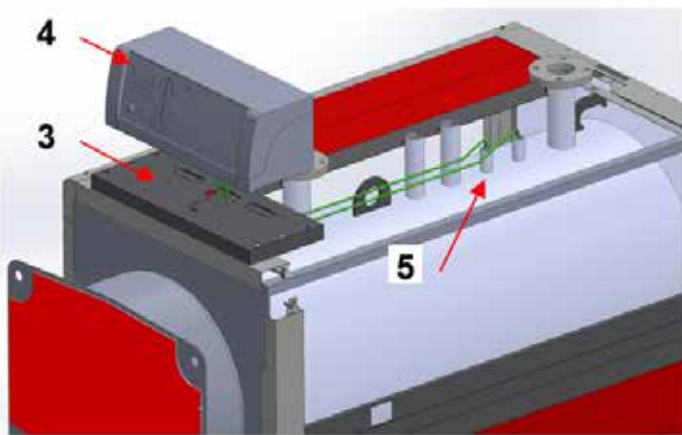

- 9) Finish inserting the lags and installing the closing profiles (2) using the self-tapping screws on the manhole side.

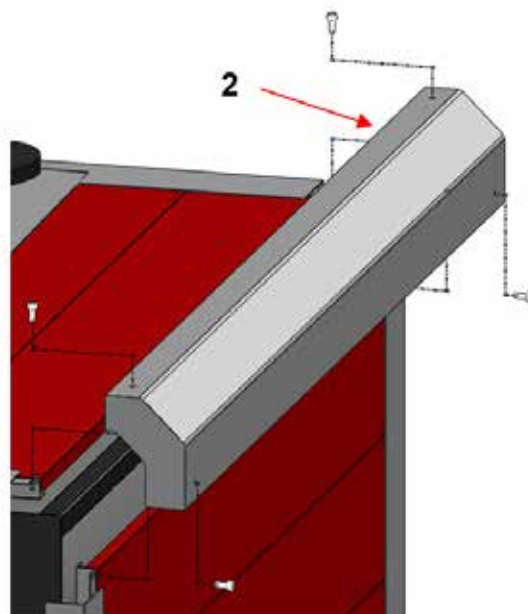



## 7. START UP

**WARNING: Before start up, open the door and insert wholly turbolators into the front end sections of the smoke tubes, ensuring that they have been pushed inside for at least 100 mm.**

### PRELIMINARY CHECKS

Before starting the boiler, check that:

- The **rating plate** specifications and power supply network (electricity, water, gas or fuel oil) specifications correspond;
- The burner **power range** is compatible with the power of the boiler;
- There is a copy of the burner instructions in the boiler room;
- The **flue gas exhaust pipe** is correctly fitted;
- The **air inlet supply** is the correct size and free from any obstacle;
- The **manhole**, the **smokebox** and the **burner plate** are closed in order to provide a complete flue gas seal;
- The system is **full of water** and that any **air pockets** have been eliminated;
- The **anti-freeze** protections are operative;
- The water **circulation pumps** are operating correctly.
- The expansion vessel and the safety valve(s) have been connected correctly (with no interception) and are properly operating.
- Check the electrical parts and thermostat operation.



### WATER TREATMENT

The most common phenomena that occur in heating systems are:

#### - **Scaling**

Scale reduces heat transfer between the combustion gases and the water, causing an abnormal increase in the temperature of the metal and therefore reducing the life of the boiler.

Scale is found mostly at the points where the wall temperature is highest and the best remedy, at construction level, is to eliminate areas that overheat.

Scale creates an insulating layer which reduces the thermal transfer of the generator, affecting system efficiency. This means that the heat produced by burning the fuel is not fully exploited and is lost to the flue

#### **Scale diagram**

##### **Key**

**%** % fuel not used

**mm** mm scale

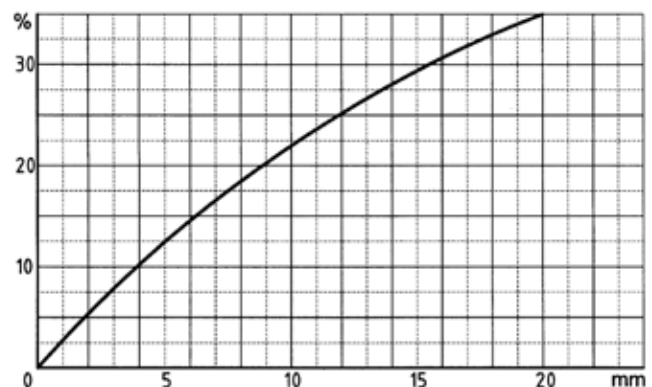

#### - **Corrosion on the water side**

Corrosion of the metal surfaces of the boiler on the water side is due to the passage of dissolved iron through its ions (Fe<sup>+</sup>). In this process the presence of dissolved gases and in particular of oxygen and carbon dioxide is very important. Corrosion often occurs with softened or demineralised water

which has a more aggressive effect on iron (acid water with Ph <7): in these cases, although the system is protected from scaling, it is not protected against corrosion and the water must be treated with corrosion inhibitors.

### FILLING THE SYSTEM

The water must enter the system as slowly as possible and in a quantity proportional to the air bleeding capacity of the components involved. Filling times vary depending on the capacity and characteristics of the system but should never be less than 2 or 3 hours.

In the case of a sealed system with an **expansion vessel**, water is let in until the pressure gauge indicator reaches the static pressure value pre-set in the vessel.

Heat the water to maximum temperature. During this operation the air contained in the water is released through the automatic air separators or through manual bleed valves. Once the air has been entirely released, reset the pressure to the pre-established value and close the manual and/or automatic filling valve.



## 8. OPERATION

### OPERATING CHECKS

The heating system must be correctly operated to ensure perfect combustion as far as possible with reduced emissions of carbon monoxide, unburnt hydrocarbons and soot into the atmosphere, and to avoid hazards and damage to people and goods. Guide to combustion values:

FUELS	%CO <sub>2</sub>	Flue gases temperature	% CO
Gas	10	190°C	0 – 20 ppm
Gas oil	13	195°C	10 – 80 ppm
Heavy oil	13.5	200°C	50 – 150 ppm

A diagram is provided in which the system efficiency is obtained according to the flue gas temperature, the ambient temperature and the percentage of carbon dioxide (CO<sub>2</sub>). Dispersions through the boiler casings are not considered.

Example

Flue gas temperature: 210 °C

Ambient temperature: 20 °C

%CO<sub>2</sub>: 13 %

Fuel used: GAS OIL

Efficiency: 91.4 %

% EFFICIENCY CHART (significant losses only)

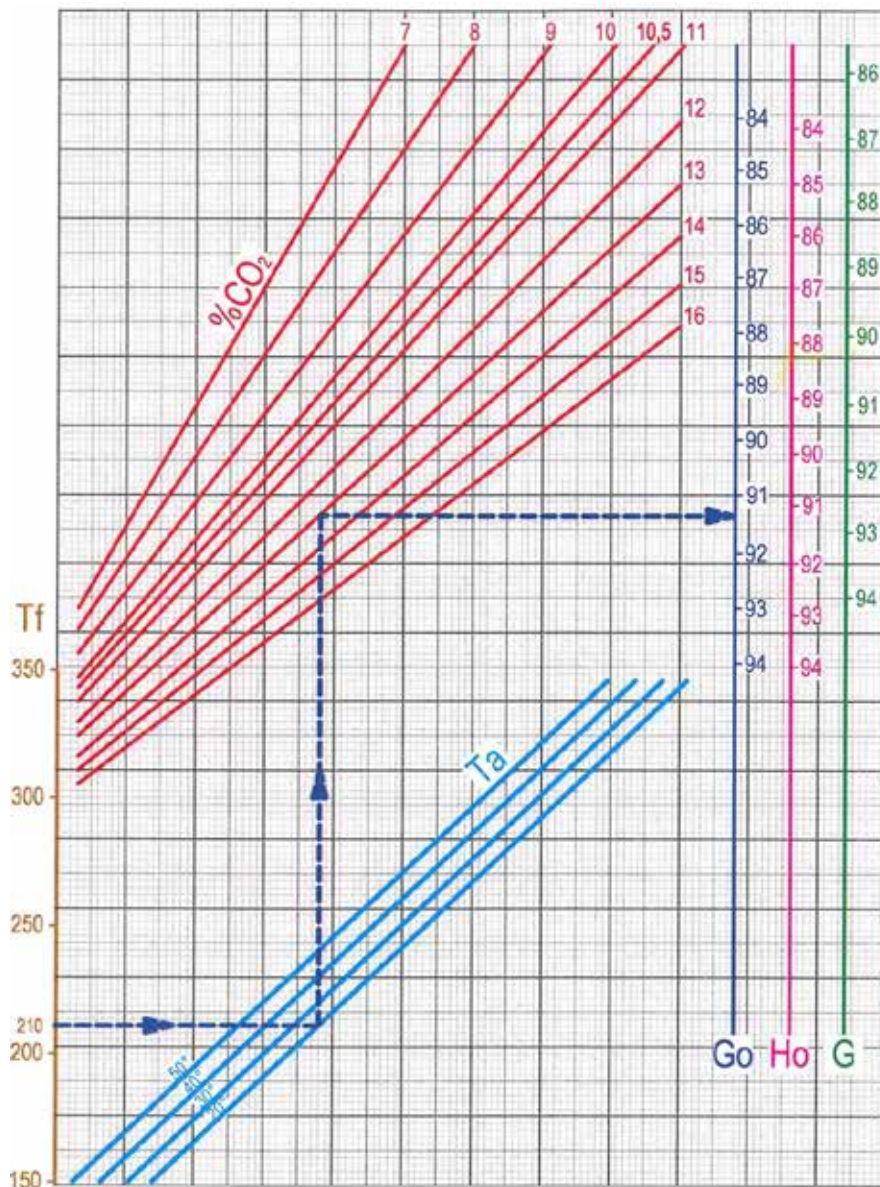

Key:

**Tf** Flue gas temperature – **Ta** Ambient temperature °C – **Go** Gas oil – **Ho** Heavy oil – **G** Gas

Pressurisation values should be included in the range given in the table of technical specifications.

**IMPORTANT**

**The delta T between flow and return must not exceed 30°C, in order to avoid thermal shocks in the boiler. The boiler return temperature must be higher than 50°C on natural gas or LPG firing and higher than 40°C on oil firing, in order to protect the boiler from corrosion due to acid flue gas condensation; the guarantee therefore does not cover damages due to condensation.**

**If the system return temperature does not fulfill the above requirements, it is necessary to increase the return temperature by using a mixing valve and/or a recirculation pump.**

**GREENOX BT COND:**

**IMPORTANT**

**The temperature gradient between flow and return, with burner running at rated output of the boiler, must range from 10°C to 25°C. This protects the generator both from excessive flow, which can cause vibrations and noise, and from hot water stagnation which causes limestone build-up and creates internal thermal shocks.**

It is recommended that the burner switch is always switched on in order to maintain water temperature approximately equal to the value the thermostat is set to.

**If the flue gas seal is poor in the front part of the boiler (manhole and burner plate) or the back part (smokebox), the closing tie rods of the individual parts must be adjusted; if this is not sufficient, the seals must be replaced.**

**CAUTION**

**Do not open the manhole and do not remove the smokebox while the burner is working. Always wait a few minutes after the burner has been switched off until the insulating parts are cooler.**

## 9. MAINTENANCE

### IMPORTANT

**Carry out thorough cleaning and periodic maintenance to ensure a correct and safe operation of the system. A perfectly clean tube bundle increases the thermal exchange between fumes and water contributing to energy saving and reducing air pollution.**

### PREPARATION FOR INSPECTION AND MAINTENANCE

**Before carrying out any kind of maintenance, in order to avoid risks, the operator must be equipped with all the personal protection provided by the standards in force.**

**Before performing any cleaning and maintenance operation, it is first necessary to disconnect the device from both the fuel and the mains supply.**

Maintenance must be entrusted only to **technically qualified personnel** and can be either mechanical or electrical.

The preparation and status of the generator may be different, depending on the operations to be performed:

- **With the boiler running**, to check the integrity of the generator when hot (fume trace seal, water side gasket seal, flue draught, operation of adjustment and safety accessories),
- **With switch-off and complete cooling** of the generator, when having to open the front door with inspection inside the furnace and fume chamber.
- **With cooling, complete emptying and safe shut-off of the generator** towards the system of use, in the case of water side internal visit.

**Particular precautions must be taken to avoid the risk of electric shock since the system on the generator has accessories powered at 230V and/or at 400V.**

**Before intervening on the generator, ensure that the connection to the electrical system has been made according to current standards, also ensuring proper earthing connection to the system.**

## ORDINARY

- Carry out burner maintenance (as to the specific instructions) and have the calibration checked by duly qualified personnel.
- Check the tightness of flange bolts and the state of the gaskets;
- Analyse the system water and make sure it is treated in such a way that scaling does not occur, as scales would not only reduce the boiler performance, but also cause potentially fatal damage to the boiler in the long run.
- Make sure that refractory cladding and fume seal gaskets are intact; if they are not, replace them;
- Check the integrity of the flame warning light.
- Periodically clean the furnace (1) and the tube bundle (2) using a brush.
- Check the integrity and cleanliness of the turbulators (3), if any; in general gaseous fuels should not produce any carbon deposit while with the use of liquid fuels, it is necessary to clean frequently to avoid substantial fouling.
- To clean more thoroughly, the smoke chamber is to be removed; in this way, carbon residues can be eliminated from the back.

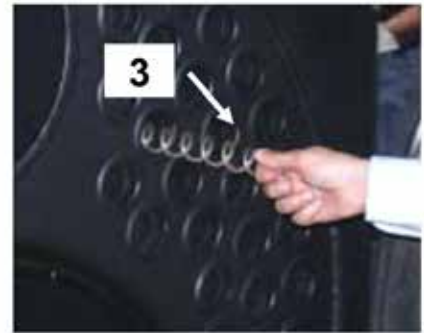
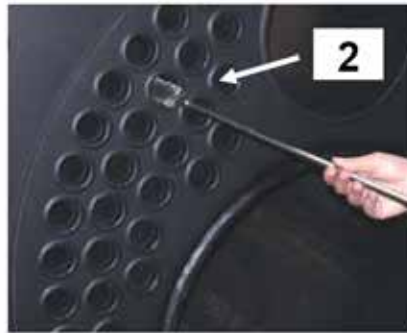
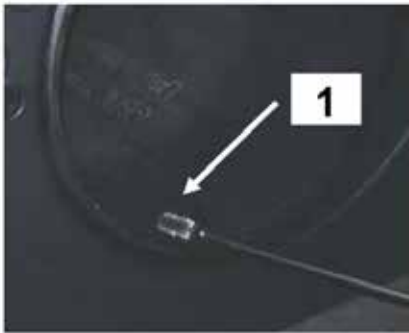

- Check the integrity of the electrical system on the generator.
- Check the integrity of the electrical panel, both outside (IP protection) and inside (check of all components inside the electrical panel).
- Periodically check the efficiency of adjusting and system safety tools.

## 10. ENVIRONMENTAL PROTECTION AND DISPOSAL

Protection and respect for the environment is a fundamental principle for **ICI CALDAIE S.p.A.**

The quality of products, lower costs and protection of the environment are of equal importance for the company. **ICI CALDAIE S.p.A.**, also through ISO 14001 certification, strictly adheres to European laws and standards for the protection and preservation of the environment.

In order to reduce its impact on the environment, the company uses the best technology and materials in its production processes and always considers their economic impact.

Thermal insulators are special waste and must therefore be disposed of in compliance with the applicable legislation.

## 11. INFORMATION FOR THE DISPOSAL OF ELECTRICAL AND ELECTRONIC EQUIPMENT

This product contains electrical and electronic equipment which cannot be disposed of through the normal means of municipal waste collection. There are separate collection centres for these products. Electrical and electronic equipment must be treated separately and in compliance with the laws in force in the respective Country.

## 12. USEFUL INFORMATION AND DECLARATIONS

### QR CODE

#### How to register your appliance



The appliance must be registered once the product has been installed, either before or after start-up.

Follow these steps:

- Obtain a smartphone (iPhone, Samsung Galaxy, Htc, Blackberry etc.) or a tablet
- after downloading and installing a "QR Reader" application (any free application is usually more than enough), open it and point the camera on the QR code located on the plate of your appliance (circled in the image)
- you will be sent back to a web page on which to register the data of your appliance and system by completing the indicated spaces.

VP05			
<b>ICI CALDAIE S.p.A.</b> Via G.Pascoli, 38 - 37059 ZEVIÒ (VR) - ITALIA -			
Tipo - Type - Typ - Modelos			
Codice - Code - Code - Codice		Data - Date	N° Fabbrica
<b>GENERATORE DI VAPORE - STEAM BOILER</b> <b>GENERATEUR DE VAPEUR - GENERADOR DE VAPOR</b>			
PORTATA TERMICA - HEAT INPUT DEBIT THERM. - POTENC. TERM.		POTENZA UTILE - HEAT OUTPUT DEBIT THERM. UTILE - POTENCIA UTIL	
MIN	KW	Kcal/h	MIN
MED/MIN	KW	Kcal/h	MED/MIN
MAX	KW	Kcal/h	MAX
TS min. =	°C	Riferimento disegno:	
PS	BAR	corpo:	
TS max esercizio	°C	insieme:	
COMBUST. LIQUIDO - LIQUID FUEL		GAS CATEG. V. CATEG. BRUC.	
SOLIDO - LIGHT OIL		TIPO - TYPE - TYP GAS	
HEAVY OIL		BRUCIATORE	
BRUCIAT. - BURNER - BRULEUR - QUEMADOR			
ALIM.ELETT.-VOLTAGE-ALIM.ELECT.-TENSION D'ALIMENT.		V. 1/N-230	
CLASSE PROJ.-PROTECT.CLAS-CLASE DE PROC.-PROTEC.		IP55	
DESTINAZIONE - DESTINATION - DEST.		CE	
(DATI CARATTERISTICI VEDI DICHIARAZ.CONFORMITA)			
S.N. Body 1:			
S.N. Body 2:			
TARGA DATI CORPO GENERATORE: VEDI FLANGIATURA INFERIORE BARILOTTO LA TARGA DATI LIVELLOSTATO E' SITUATA ALL'INTERNO DEL QUADRO ELETTRICO.			

Once registered, authenticate your e-mail address by clicking on the link that will be sent by e-mail to the provided inbox.

An additional e-mail will then be received with the credentials to access all services specifically developed by **ICI CALDAIE S.p.A.** for those who will register their boiler through the QR Code.

Registration entitles you, even in future months and years, to take advantage of promotions and specific services for registered appliances (e.g.: discounts on spare parts, spare parts kits on sale, free routine maintenance for certain types of products, etc.).

For information, contact the ICI headquarter or the local representative offices.

[www.icaldaie.com](http://www.icaldaie.com) - [info@icaldaie.com](mailto:info@icaldaie.com)



ICI CALDAIE SpA  
Via G. Pascoli, 38  
37059 Campagnola di Zevio VR

Telefono 045 8738511  
Fax 045 8731148  
Info@icicaldaie.com  
www.icicaldaie.com

Partita Iva 00227490232  
Rag. Soc. n. 6677  
C.C.I.A.A. VR n. 69600

Appartenente al Gruppo Finluc  
Iscritto R.I. VR 02245640236

## **DECLARATION OF CONFORMITY WITH THE EUROPEAN COMMUNITY REGULATIONS**

I undersigned Emanuela Lucchini, Managing Director of ICI CALDAIE S.p.A., headquartered in via G. Pascoli 38 – 37059 Campagnola di Zevio (VR) Italy

**DECLARE THAT STEEL BOILERS**

### **GREENOx.e GREENOx BT COND**

comply with the CE certificate and in accordance with the boards regulations:

- Gas Directive 2009/142/CE (Rif. EN 303)
- Efficiency Directive 92/42/CEE
- EMC Directive 2014/30/UE
- Low Voltage Directive 2014/35/UE

S. Maria di Zevio, li 04/08/2015

ICI CALDAIE S.p.A.  
Direttore Generale  
Emanuela Lucchini

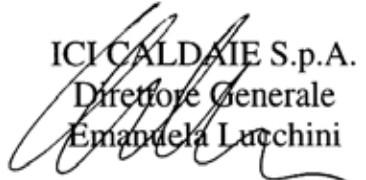





## **ICI CALDAIE SpA**

37059 Fraz. Campagnola di Zevio (Verona) Italy

Via G. Pascoli 38 Phone: +39 0458738511 Fax: +39 0458731148

info@icaldaie.com www.icaldaie.com