

	<b>AIR-COOLED MODULAR CHILLER AND HEAT PUMP</b>	
<b>INSTALLATION, COMMISSIONING, OPERATION &amp; MAINTENANCE</b>	Supersedes: NOTHING	FORM NO.: 6U6H-B01C-NB-EN

**YCAE065/100/130-X**  
**AIR-COOLED MODULAR CHILLER AND HEAT PUMP**  
**50Hz**



**R410A**

Issue Date:  
 October 31, 2018

---

# IMPORTANT!

## READ BEFORE PROCEEDING!

### GENERAL SAFETY GUIDELINES

This equipment is a relatively complicated apparatus. During rigging, installation, operation, maintenance, or service, individuals may be exposed to certain components or conditions including, but not limited to: heavy objects, refrigerants, materials under pressure, rotating components, and both high and low voltage. Each of these items has the potential, if misused or handled improperly, to cause bodily injury or death. It is the obligation and responsibility of rigging, installation, and operating/service personnel to identify and recognize these inherent hazards, protect themselves, and proceed safely in completing their tasks. Failure to comply with any of these requirements could result in serious damage to the equipment and the property in which it is situated, as well as severe personal injury or death to themselves and people at the site.

This document is intended for use by owner-authorized rigging, installation, and operating/service personnel. It is expected that these individuals possess independent training that will enable them to perform their assigned tasks properly and safely. It is essential that, prior to performing any task on this equipment, this individual shall have read and understood the on-product labels, this document and any referenced materials. This individual shall also be familiar with and comply with all applicable industry and governmental standards and regulations pertaining to the task in question.

---

### SAFETY SYMBOLS

The following symbols are used in this document to alert the reader to specific situations:



***Indicates a possible hazardous situation which will result in death or serious injury if proper care is not taken.***



***Identifies a hazard which could lead to damage to the machine, damage to other equipment and/or environmental pollution if proper care is not taken or instructions and are not followed.***



***Indicates a potentially hazardous situation which will result in possible injuries or damage to equipment if proper care is not taken.***

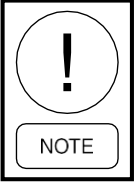

***Highlights additional information useful to the technician in completing the work being performed properly.***



***External wiring, unless specified as an optional connection in the manufacturer's product line, is not to be connected inside the control cabinet. Devices such as relays, switches, transducers and controls and any external wiring must not be installed inside the micro panel. All wiring must be in accordance with Johnson Controls' published specifications and must be performed only by a qualified electrician. Johnson Controls will NOT be responsible for damage/problems resulting from improper connections to the controls or application of improper control signals. Failure to follow this warning will void the manufacturer's warranty and cause serious damage to property or personal injury.***

---

## CHANGEABILITY OF THIS DOCUMENT

In complying with Johnson Controls' policy for continuous product improvement, the information contained in this document is subject to change without notice. Johnson Controls makes no commitment to update or provide current information automatically to the manual or product owner. Updated manuals, if applicable, can be obtained by contacting the nearest Johnson Controls Service office or accessing the Johnson Controls website.

It is the responsibility of rigging, lifting, and operating/ service personnel to verify the applicability of these documents to the equipment. If there is any question regarding the applicability of these documents, rigging, lifting, and operating/service personnel should verify whether the equipment has been modified and if current literature is available from the owner of the equipment prior to performing any work on the chiller.

### CHANGE BARS

Revisions made to this document are indicated with a line along the left or right hand column in the area the revision was made. These revisions are to technical information and any other changes in spelling, grammar or formatting are not included.

---

## ASSOCIATED LITERATURE

MANUAL DESCRIPTION	FORM NUMBER
SC-EQ Communication Card Installation Instructions	450.50-N1

---

## SINGLE CIRCUIT AND DUAL CIRCUIT MODELS

This manual contains installation, operation and maintenance instructions for both single and dual refrigerant circuit models. If your unit is a single circuit model (YCAE065X), disregard references to "System 2" which may appear in this manual. Any references to System 2 are applicable to YCAE100/130X models.

---

**BASIC UNIT NOMENCLATURE**

NAME	Y	C	A	E	1	3	0	X	R	M	E	5	0
PIN	1	2	3	4	5	6	7	8	9	10	11	12	13
1	Y: YORK												
2	C: Chiller												
3	A: Air-cooled												
4	E: Scroll Compressor												
5/6/7	Rated Cooling Capacity: 65-65kW; 100-100kW; 130-130kW												
8	X: Product Series												
9	R: R-Heat Pump												
10	M: Modular												
11	E: Refrigerant R410A												
12/13	50: Power Supply 380V/3N/50Hz												

## Contents

<b>SECTION 1 – GENERAL INFORMATION AND SAFETY</b> .....	8
<b>INTRODUCTION</b> .....	8
<b>WARRANTY</b> .....	8
<b>SAFETY</b> .....	9
<b>MISUSE OF EQUIPMENT</b> .....	9
<b>SECTION 2 – PRODUCT DESCRIPTION</b> .....	12
<b>INTRODUCTION</b> .....	12
<b>GENERAL SYSTEM DESCRIPTION</b> .....	12
<b>POWER PANEL</b> .....	13
<b>ACCESSORIES</b> .....	14
<b>OPTIONS</b> .....	14
<b>SECTION 3 – HANDLING AND STORAGE</b> .....	16
<b>LIFTING WEIGHTS</b> .....	16
<b>DELIVERY AND STORAGE</b> .....	16
<b>OPERATING AND STORAGE CONDITIONS</b> .....	17
<b>INSPECTION</b> .....	17
<b>MOVING THE UNIT BY FORKLIFT TRUCKS</b> .....	17
<b>SECTION 4 – INSTALLATION</b> .....	18
<b>INSTALLATION CHECKLIST</b> .....	18
<b>HANDLING</b> .....	18
<b>INSPECTION</b> .....	18
<b>LOCATION AND CLEARANCES</b> .....	18
<b>ISOLATORS (OPTIONAL)</b> .....	20
<b>COMPRESSOR MOUNTING</b> .....	20
<b>CHILLED LIQUID PIPING</b> .....	20
<b>PIPEWORK ARRANGEMENT</b> .....	22
<b>WIRING</b> .....	23
<b>POWER SUPPLY CONNECTION</b> .....	26
<b>CONTROL WIRING</b> .....	28
<b>SECTION 5 – TECHNICAL DATA</b> .....	31
<b>PHYSICAL DATA</b> .....	31
<b>ELECTRICAL DATA</b> .....	32
<b>ELECTRICAL DIAGRAM</b> .....	32
<b>DIP SWITCH SETTING</b> .....	36
<b>DIMENSIONS</b> .....	38
<b>CLEARANCES</b> .....	39
<b>SECTION 6 – COMMISSIONING</b> .....	40
<b>COMMISSIONING</b> .....	40
<b>PREPARATION – POWER OFF</b> .....	40
<b>PREPARATION – POWER ON</b> .....	41
<b>UNIT OPERATING SEQUENCE</b> .....	42
<b>SECTION 7 – WIRE CONTROLLER OPERATION</b> .....	44

---

<b>INTRODUCTION</b> .....	44
<b>BASIC OPERATIONS</b> .....	45
<b>ADVANCED OPERATIONS</b> .....	45
<b>SECTION 8 – MAINTENANCE</b> .....	48
<b>IMPORTANT</b> .....	48
<b>COMPRESSORS</b> .....	48
<b>CONDENSER COILS</b> .....	48
<b>OPERATING PARAMETERS</b> .....	48
<b>CONDENSER FAN MOTORS</b> .....	48
<b>OVERALL UNIT INSPECTION</b> .....	48
<b>EXPANSION TANK</b> .....	49
<b>ModBus Protocol</b> .....	50
<b>PRESSURE TRANSDUCER DIAGRAM</b> .....	59
<b>R410A PRESSURE TEMPERATURE CHART</b> .....	60

---

## SECTION 1 – GENERAL INFORMATION AND SAFETY

### INTRODUCTION

YORK YCAE065/100/130X (18-36 ton, 65-130 kW) chillers and heat pumps are manufactured to the highest design and construction standards to ensure high performance, reliability and adaptability to all types of air conditioning installations.

The unit combines a multiple step control design with tandem technology allowing the unit's compressors to operate more efficiently across all capacity-load and ambient-temperature conditions.

The unit is intended for cooling and heating water and is not suitable for purposes other than those specified in this manual.

This manual contains all the information required for correct installation and commissioning of the unit, together with operating and maintenance instructions. The manual should be read thoroughly before attempting to operate or service the unit.

All procedures detailed in the manual, including installation, commissioning and maintenance tasks must only be performed by suitably trained and qualified personnel.

The manufacturer will not be liable for any injury or damage caused by incorrect installation, commissioning, operation or maintenance resulting from a failure to follow the procedures and instructions detailed in the manual.

### WARRANTY

Johnson Controls warrants all equipment and materials against defects in workmanship and materials for a period of one year from date of initial start-up or eighteen (18) months from date of shipment, whichever occurs first, unless labor or extended warranty has been purchased as part of the contract.

The warranty is limited to parts only replacement and shipping of any faulty part, or sub-assembly, which has failed due to poor quality or manufacturing errors. All claims must be supported by evidence that the failure has occurred within the warranty period, and that the unit has been operated within the designed parameters specified.

All warranty claims must specify the unit model, serial number, order number and run hours/starts. Model and serial number information is printed on the unit identification plate.

The unit warranty will be void if any modification to the unit is carried out without prior written approval from Johnson Controls.

For warranty purposes, the following conditions must be satisfied:

- The initial start of the unit must be carried out by trained personnel from an Authorized Johnson Controls Service Center.
- Only genuine YORK approved spare parts, oils, coolants, and refrigerants must be used.
- All the scheduled maintenance operations detailed in this manual must be performed at the specified times by suitably trained and qualified personnel.



- Failure to satisfy any of these conditions will automatically void the warranty.

## **SAFETY**

YCAE-X units are designed and built within an ISO 9001 accredited design and manufacturing organization.

### **Fluorinated Greenhouse Gases**

- This equipment contains fluorinated greenhouse gases covered by the Kyoto Protocol.
- The GWP (global warming potential) of the refrigerant (R410A) used in this unit is 2088.
- The refrigerant quantity is stated in the Physical Data table of this document.
- The fluorinated greenhouse gases in this equipment may not be vented to the atmosphere.
- This equipment should only be serviced by qualified technicians.

### **Responsibility for Safety**

Every care has been taken in the design and manufacture of the unit to ensure compliance with the safety requirements listed above. However, the individual operating or working on any machinery is primarily responsible for:

- Personal safety, safety of other personnel, and the machinery.
- Correct utilization of the machinery in accordance with the procedures detailed in the manuals.

The contents of this manual include suggested best working practices and procedures. These are issued for guidance only, and they do not take precedence over the above stated individual responsibility and/or local safety regulations.

This manual and any other document supplied with the unit are the property of Johnson Controls which reserves all rights. They may not be reproduced, in whole or in part, without prior written authorization from an authorized Johnson Controls representative.

## **MISUSE OF EQUIPMENT**

### **Suitability for Application**

The unit is intended for cooling/heating water or glycol solutions and is not suitable for purposes other than those specified in these instructions. Any use of the equipment other than its intended use, or operation of the equipment contrary to the relevant procedures may result in injury to the operator, or damage to the equipment.

The unit must not be operated outside the design parameters specified in this manual.

### **Structural Support**

Structural support of the unit must be provided as indicated in these instructions. Failure to provide proper support may result in injury to the operator, or damage to the equipment and/or building.

### **Mechanical Strength**

The unit is not designed to withstand loads or stresses from adjacent equipment, pipework or structures. Additional components must not be mounted on the unit. Any such extraneous loads may cause structural failure and may result in injury to the operator, or damage to the equipment.

### **General Access**

There are a number of areas and features, which may be a hazard and potentially cause injury when working on the unit unless suitable safety precautions are taken. It is important to ensure access to the unit is restricted to suitably qualified persons who are familiar with the potential hazards and precautions necessary for safe operation and maintenance of equipment containing high temperatures, pressures and voltages.

### **Pressure Systems**

The unit contains refrigerant vapor and liquid under pressure, release of which can be a danger and cause injury. The user should ensure that care is taken during installation, operation and maintenance to avoid damage to the pressure system. No attempt should be made to gain access to the component parts of the pressure system other than by suitably trained and qualified personnel.

### **Electrical**

The unit must be grounded. No installation or maintenance work should be attempted on the electrical equipment without first switching power OFF, isolating and locking-off the power supply. Servicing and maintenance on live equipment must only be performed by suitably trained and qualified personnel. No attempt should be made to gain access to the control panel or electrical enclosures during normal operation of the unit.

### **Heat Radiation**

Some of the visible parts like discharge pipe may work under high temperatures, thus radiate high heat flux. Special attention must be paid while getting close to the unit. Touching is prohibited during normal operation.

### **Rotating Parts**

Fan guards must be fitted at all times and not removed unless the power supply has been isolated.

### **Sharp Edges**

The fins on the air-cooled condenser coils have sharp metal edges. Reasonable care should be taken when working in contact with the coils to avoid the risk of minor abrasions and lacerations. The use of gloves is recommended.

Frame rails, panels, and other components may also have sharp edges. Reasonable care should be taken when working in contact with any components to avoid risk of minor abrasions and lacerations.

### **Refrigerants and Oils**

Refrigerants and oils used in the unit are generally non-toxic, non-flammable and non-corrosive, and pose no special safety hazards. They are pre-charged before delivery to customer and normally dispense with the need of additional charging, unless the machine is not working properly.



---

Use of gloves and safety glasses is, however, recommended when working on the unit. The buildup of refrigerant vapor, from a leak for example, does pose a risk of asphyxiation in confined or enclosed spaces and attention should be given to good ventilation.

### **High Temperature and Pressure Cleaning**

High temperature and pressure cleaning methods (e.g. steam cleaning) should not be used on any part of the pressure system as this may cause operation of the pressure relief device(s). Detergents and solvents, which may cause corrosion, should also be avoided.

---

## SECTION 2 – PRODUCT DESCRIPTION

### INTRODUCTION

YORK Air-Cooled Modular Chiller and Heat Pump provide chilled water or (and) hot water for all air conditioning applications using central station air handling or terminal units. They are completely self-contained and are designed for outdoor (roof or ground level) installation. Each complete packaged unit includes hermetic scroll compressors, a liquid cooler, air cooled condensers, a charge of refrigerant R410A and a weather resistant microprocessor control center, all mounted on a welded steel base.

The units are completely assembled with all interconnecting refrigerant piping and internal wiring, ready for field installation.

Prior to delivery, the packaged unit is pressure-tested, evacuated, and fully charged with Refrigerant R410A and oil. After assembly, a complete operational test is performed with water flowing through the cooler to assure that the refrigeration circuit operates correctly.

The unit structure is heavy-gauge, galvanized steel. This galvanized steel is coated with baked-on powder paint, which, when subjected to ISO 9227 500 hour, salt spray testing, yields a minimum ISO 10289 rating of “6”. Corrosion resistant wire mesh grills and lower panels are added to protect the condenser coil from incidental damage and restrict unauthorized access to internal components.

All exposed power wiring is routed through liquid-tight, UV-stabilized, non-metallic conduit.

### GENERAL SYSTEM DESCRIPTION

#### Compressor

The unit has fixed speed, hermetic, scroll compressors. High efficiency is achieved through a controlled orbit and the use of advanced scroll geometry. The compressors incorporate a compliant scroll design in both the axial and radial direction. All rotating parts are statically and dynamically balanced. A large internal volume and oil reservoir provides greater liquid tolerance. Compressor crankcase heaters are also included for extra protection against liquid migration.

#### Refrigerant Circuits

One or two independent refrigerant circuits are provided on each unit. Each circuit uses copper refrigerant pipe formed on computer controlled bending machines to reduce the number of brazed joints resulting in a reliable and leak resistant system.

Each circuit shall incorporate all components necessary for the designed operation including: a suction accumulator, a liquid receiver, a four way reversing valve, service valves, a bi-flow electrical expansion valve. Suction lines shall be covered with closed-cell insulation.

#### Evaporator (Heat Exchanger)

The compact, high efficiency Braze Plate Heat Exchanger (BPHE) is constructed with 316 stainless steel corrugated channel plates with a filler material between each plate. It offers excellent heat transfer performance with a compact size and low weight, reducing structural steel requirements on

the job site.

The heat exchanger is manufactured in a precisely controlled vacuum-brazing process that allows the filler material to form a brazed joint at every contact point between the plates, creating complex channels.

The units with two refrigerant systems use dual circuit BPHEs. Asymmetric channels provide optimal efficiency in the most compact design. This results in low refrigerant charge or lower pressure drop on the water or brine side. The asymmetry guarantees the best performance in both full and partial-load conditions. The integrated distribution system ensures an even distribution of the refrigerant throughout the plate package.

The refrigerant side design working pressure of the heat exchanger is 45 bar and the waterside (piping) design working pressure is 10 bar.

The cooler is covered with 7/8" (19mm) flexible, closed-cell, foam insulation.

Installing contractor must include accommodations in the chilled water piping to allow proper drainage and venting of the heat exchanger. Water inlet and outlet connections are grooved for compatibility with factory supplied victaulic connections (except 65 kW unit with thread connections).

A strainer with a mesh size 0.3 mm (50 mesh) is recommended upstream of the heat exchanger to prevent clogging.

A factory-wired flow switch is standard, installed in a pipe section at the outlet of the evaporator.

## **Condenser**

Coils – Fin and tube condenser coils of seamless, internally-enhanced, high-condensing-coefficient, corrosion resistant copper tubes are arranged in staggered rows, mechanically expanded into hydrophilic aluminum fins. The design working pressure of the coil is 45 bar (650 PSIG).

Fans – The condenser fans are designed for maximum efficiency with two-staged fan motor. The fans are positioned for vertical air discharge. All blades are statically and dynamically balanced for vibration-free operation. The fan grilles are constructed of heavy-gauge, rust-resistant, coated steel.

AC Motors – The fans are directly driven by two-staged motors. Thermal loading protection is integrated. They feature ball bearings that are double-sealed and permanently lubricated.

## **POWER PANEL**

The control elements are fitted in a factory installed and wired IP55 rain/dust tight, powder painted steel cabinets with tool lockable, hinged, latched, and gasket sealed outer doors. Main power connection(s), compressor starters, fan motor contactors, current overloads are provided and factory wired.

A unit-mounted Circuit Breaker with external lockable handle shall be provided at the point of incoming single point connection for field connection, interconnecting wiring to the compressors, and isolating the power voltage for servicing. Incoming power wiring must comply with local codes. Circuit breaker shall be sized to provide the motor branch circuit protection, short circuit protection and ground fault protection for the motor branch-circuit conductors, the motor control apparatus and the motors.

Power panel contains:

- IPU3 (including I/O board and core board)
- Compressor and fan contactors
- Compressor thermal relays
- Power sequence protector
- Power and control wiring terminals
- Compressor power terminals

Short Circuit Withstand Rating of the unit electrical enclosure shall be (380V: 5,000 Amps).

The power wiring is routed through liquid-tight conduit to the compressors and fans.

## **ACCESSORIES**

**DISCHARGE PRESSURE TRANSDUCERS** – The addition of pressure transducers allows models to sense and display discharge pressure. This allows the unit to automatically adjust condenser fan speed to suit different ambient conditions, as well as protect the unit from over pressure (Factory-Mounted).

**SUCTION PRESSURE TRANSDUCERS** - Permits unit to sense and display suction pressure. This capability is standard on all models. The suction pressure is monitored for system superheat control (Factory-Mounted).

**TOUCH SCREEN WIRE CONTROLLER** – The wire controller is applicable for dual HMI control, together with optional 7 inch HMI. Both of the controllers are valid to operate the unit simultaneously (Field- Mounted).

**FLOW SWITCH** –Vapor proof, paddle-type with 1"NPT connection for upright mounting in horizontal pipe. This flow switch or its equivalent must be supplied with each unit to protect the heat exchanger from loss of liquid flow (Factory Mounted).

## **OPTIONS**

### **HMI CONTROLLER**

The HMI is contained in a protection class IP54 cabinet installed in the middle beam with hinged outer door and includes a 7-inch capacitive touch screen controller backlighting for outdoor viewing.

Different operation levels are accessible for viewer, operator and service. Password will be required for high level entries. Refer to Optiview LT OPERATION for details.

**AESTHETIC ENCLOSURE PANELS** (Special Quotation\*) – Welded wire mesh guards mounted over the condenser coils and louvered panels mounted around the bottom of the unit. Tamperproof Enclosure Panels prevent unauthorized access to units. Enclosure Panels can provide an aesthetically pleasing alternative to expensive fencing (Factory-Mounted).

**SC-EQ CARD** – The SC-EQUIP (SC-EQ) Communication Card supersedes the E-Link Gateway and provides BAS network connectivity for equipments like YCAE. It is designed with four active serial



---

ports: The J12 BAS (RS-485) port, the J7 Equipment (RS-232) port, the J8 Equipment (RS-485) port and the J11 CS port which allows equipment data to be sent to the Johnson Controls Remote Operation Center for remote unit monitoring and diagnostics. Refer to Wiring Diagram for details (Factory-Mounted).

VIBRATION ISOLATORS – Level adjusting, spring type 1” (25.4mm) or seismic deflection or neoprene pad isolators for mounting under unit base rails (Field- Mounted).

WATER TEMPERATURE SENSOR – An additional outlet water temperature sensor will be required for modular control. The sensor is used for compressor sequencing and water side protections (Field-Mounted).

## SECTION 3 – HANDLING AND STORAGE



# WARNING

Failure to follow these instructions could result in death, serious injury or equipment damage.

Follow all warnings and instructions in the unit's Manual(s).

<p><b>EN</b> Installation Instructions for the technician / fitter</p> <p><b>PL</b> Instrukcja instalacji dla technika / monter</p> <p><b>SV</b> Installationsguide för installatör / montör</p> <p><b>CS</b> Pokyny k instalaci pro techniky a montéry</p> <p><b>HU</b> Telepítési utasítás gyakorlott szervizmérnök / kivitelező részére</p>	<p><b>IT</b> Istruzioni d'installazione per il personale specializzato</p> <p><b>NL</b> Installatiehandleiding voor de vakman / monteur</p> <p><b>DE</b> Installationsanleitung für die Fachkraft / Monteur</p> <p><b>ES</b> Instrucciones de instalación para el técnico / contratista especializado</p> <p><b>PT</b> Instruções de instalação para o técnico / instalador</p>	<p><b>JA</b> 一般仕様・取扱説明書</p> <p><b>FR</b> Manuel d'installation pour le spécialiste / monteur</p> <p><b>RU</b> Инструкция по установке для техника/монтажника</p> <p><b>ZH</b> 适用于技术人员与安装人员的 安装说明书</p> <p><b>KO</b> 기술자 / 설비기술자에 대한 설치 지침</p>
--	---	--



1. Follow all applicable regulations and safety practices during rigging and lifting.
2. Prepare and follow written rigging and lifting plan.
3. Rigging must be directed by trained professional rigger.
4. Spreader bars must be used and be long enough to prevent rigging from contacting unit.
5. Use all and only designated lift points according to units manual(s).
6. Locate center of gravity through trial lifts to account for possible variations in unit configuration.
7. Use rigging and lifting techniques that keep unit stable and level.
8. Keep clear of unit when lifted.

035-23962-000 REV B



***Rigging and lifting should only be done by a professional rigger in accordance with a written rigging and lifting plan. The most appropriate rigging and lifting method will depend on job specific factors, such as the rigging equipment available and site needs. Therefore, a professional rigger must determine the rigging and lifting method to be used, and it is beyond the scope of this manual to specify rigging and lifting details.***

### LIFTING WEIGHTS

Refer to the unit nameplate for unit shipping weight. Note that weight may vary depending on unit configuration at the time of lifting. Refer to the Physical Data tables within this manual for further information regarding shipping and operating weights.

### DELIVERY AND STORAGE

To ensure consistent quality and maximum reliability, all units are tested and inspected before leaving the factory. Units are shipped completely assembled and containing refrigerant under pressure. Units are shipped without export crating unless crating has been specified on the Sales Order.

If the unit is to be put into storage, prior to installation, the following precautions should be observed:



- The unit must be “blocked” so that the base is not permitted to sag or bow.
- Ensure that all openings, such as water connections, are securely capped.
- Do not store where exposed to high ambient air temperatures that may exceed relief valve settings.
- The condensers should be covered to protect the coils and fins from potential damage and corrosion, particularly where building work is in progress.
- The unit should be stored in a location where there is minimal activity in order to limit the risk of accidental physical damage.
- To prevent inadvertent operation of the pressure relief devices the unit must not be steam cleaned.
- It is recommended that the unit is periodically inspected during storage.

## **OPERATING AND STORAGE CONDITIONS**

Standard leaving chilled water temp: 5~20°C

Standard ambient at cooling mode: 10~48°C

Standard leaving hot water temp.: 25~55°C

Ambient temp. at heating mode: -15~25°C

Unit storage ambient temp.: -20~55°C

## **INSPECTION**

Remove any transit packing and inspect the unit to ensure that all components have been delivered and that no damage has occurred during transit. If any damage is evident, it should be noted on the carrier’s freight bill and a claim entered in accordance with the instructions given on the advice note.

Major damage must be reported immediately to your local Johnson Controls representative.

## **MOVING THE UNIT BY FORKLIFT TRUCKS**

For models of YCAE065-130, it is recommended that the units are moved by forklift trucks for transit transfer. A wooden pallet is added for forklift use before shipment.

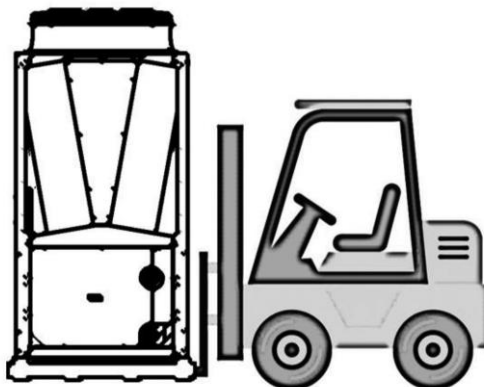

## SECTION 4 – INSTALLATION



*To ensure warranty coverage, this equipment must be commissioned and serviced by an authorized YORK service mechanic or a qualified service person experienced in unit installation.*

Installation must comply with all applicable codes, particularly in regard to electrical wiring and other safety elements such as relief valves, HP cutout settings, design working pressures, and ventilation requirements consistent with the amount and type of refrigerant charge.

Lethal voltages exist within the control panels. Before servicing, open and tag all disconnect switches.

### INSTALLATION CHECKLIST

The following items, 1 through 5, must be checked before placing the units in operation.

1. Inspect the unit for shipping damage.
2. Rig unit using spreader bars.
3. Open the unit only to install water piping system. Do not remove protective covers from water connections until piping is ready for attachment. Check water piping to ensure cleanliness.
4. Pipe unit using good piping practice.
5. Check to see that the unit is installed and operated within limitations (Refer to Operational Limitations).

The following pages outline detailed procedures to be followed to install and start-up the unit.

### HANDLING

These units are shipped as completely assembled units containing full operating charge, and care should be taken to avoid damage due to rough handling.

### INSPECTION

Immediately upon receiving the unit, it should be inspected for possible damage which may have occurred during transit. If damage is evident, it should be noted in the carrier's freight bill.

A written request for inspection by the carrier's agent should be made at once.

### LOCATION AND CLEARANCES

These units are designed for outdoor installations on ground level, rooftop, or besides a building. Location should be selected for minimum sun exposure and away from boiler flues and other sources of airborne chemicals that could attack the ambient coils and steel parts of the unit. The units must be installed with sufficient clearances for air entrance to the condenser coil to ensure adequate supply of fresh air, for air discharge away from the condenser, and for servicing access.

In installations where winter operation is intended and snow accumulations are expected, additional

height must be provided to prevent ice accretion in base frame of the unit.

Clearances are listed under “Notes” in the Dimensions section. The clearances recommended are nominal for the safe and efficient operation and maintenance of the unit and power and control panels. Local Health and safety regulations, or practical considerations for service replacement of large components, may require larger clearances than those given in this manual.

### **Foundation**

The unit should be mounted on a flat and level foundation, floor, or rooftop capable of supporting the entire operating weight of the equipment. See PHYSICAL DATA for operating weight.

If the unit is elevated beyond the normal reach of service personnel, a suitable catwalk must be capable of supporting service personnel, their equipment, and the compressors.

### **Ground Level Locations**

It is important that the units be installed on a substantial base that will not settle. A one piece concrete slab with footers extended below the frost line is highly recommended.

Additionally, the slab should not be tied to the main building foundations as noise and vibration may be transmitted. Mounting holes are provided in the steel channel for bolting the unit to its foundation (see Dimensions section).

For ground level installations, precautions should be taken to protect the unit from tampering by or injury to unauthorized persons. Screws and/or latches on access panels will prevent casual tampering. However, further safety precautions such as a fenced-in enclosure or locking devices on the panels may be advisable. This will help to prevent the possibility of vandalism, accidental damage, or possible harm caused by unauthorized removal of protective guards or opening panels to expose rotating or electrically live components.

### **Rooftop Locations**

Choose a spot with adequate structural strength to safely support the entire weight of the unit and service personnel. Care must be taken not to damage the roof.

The unit can be mounted on a concrete slab, similar to ground floor locations, or on steel channels of suitable strength. The channels should be spaced with the same centers as the unit side and front base rails. This will allow vibration isolators to be fitted if required.

Consult the building contractor or architect if the roof is bonded.

Roof installations should have wooden beams (treated to reduce deterioration), cork, rubber, or vibration isolators under the base to minimize vibration. Isolators are recommended for rooftop locations.

### **Noise Sensitive Locations**

Efforts should be made to assure that the unit is not located next to occupied spaces or noise sensitive areas where unit noise level would be a problem. Unit noise is a result of compressor and fan operation. Considerations should be made utilizing noise levels published in the YORK Engineering Guide for the specific unit model. Sound blankets for the compressors and enclosure panels are

available as options.

### **Cold Climate Locations**

If the unit is operating in low ambient temperature, be sure to follow the instructions listed below.

1. A baffle plate installed on the airside of the unit is recommended to prevent exposure to snow in winter.
2. In heavy snowfall areas, make sure the coil and fan will not be affected by the snow. Construct a lateral canopy if necessary.
3. Deice before operating if the fan blades fail to rotate after long time standby in snow.
4. Flexible hoses must be installed to ensure effective condensation water drainage while operating.

### **Corrosion Locations**

The unit is designed to withstand most of the climate conditions. If the unit is installed near the sea where high levels of salt may shorten the life of the unit, make sure it is not exposed to sea winds directly.

For any units being installed at the seashore, or where salt spray may hit the units, or where acid rain is prevalent, please contact Johnson Controls.

### **ISOLATORS (OPTIONAL)**

An optional set of vibration isolators can be supplied loose with each unit. When ordered, four (4) isolators will be furnished if the unit is installed without pump kit. Two (2) additional isolators will be required if pump kit is picked.

Identify the isolator, locate at the proper mounting point, and adjust per instructions.

### **COMPRESSOR MOUNTING**

The compressors are mounted on four (4) rubber or steel isolators. The mounting bolts should not be loosened or adjusted at installation of the unit.

### **CHILLED LIQUID PIPING**

General – When the unit(s) has been located in its final position, the unit water piping may be connected. Normal installation precautions should be observed in order to receive maximum operating efficiencies. Piping should be kept free of all foreign matter. All chilled water evaporator piping must comply in all respects with local plumbing codes and ordinances.

Since elbows, tees and valves decrease pump capacity, all piping should be kept as straight and as simple as possible. All piping must be supported independent of the unit.

Consideration should be given to compressor and control panel access when laying out water piping. Routing the water piping too close to the unit could make compressor/ control panel servicing/ replacement difficult.

Hand stop valves should be installed in all lines to facilitate servicing.

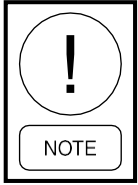

***Piping to the inlet and outlet connections of the unit should include high-pressure rubber hose or piping loops to ensure against transmission of water pump vibration. The necessary components must be obtained in the field.***

Drain connections should be provided at all low points to permit complete drainage of the cooler and system water piping.

A small valve or valves should be installed at the highest point or points in the chilled water piping to allow any trapped air to be purged. Vent and drain connections should be extended beyond the insulation to make them accessible.

The piping to and from the cooler must be designed to suit the individual installation. It is important that the following considerations be observed:

1. The chilled liquid piping system should be laid out so that the circulating pump discharges directly into the cooler. The suction for this pump should be taken from the piping system return line and not the cooler. This piping scheme is recommended, but is not mandatory.
2. Standard pipework connections are thread or Victaulic connections. The inlet and outlet cooler connection sizes are 2" (YCAE065X, thread connection), 2-1/2" (YCAE100/0130X, Victaulic connection).
3. A strainer is integrated in the cooler inlet line just ahead of the cooler for YCAE100/130X. This is important to protect the cooler from entrance of large particles which could cause damage to the evaporator. The strainer is shipped loose for YCAE065X.
4. All chilled liquid piping should be thoroughly flushed to free it from foreign material before the system is placed into operation. Use care not to flush any foreign material into or through the cooler. It is recommended that a suitably sized bypass and valve arrangement be installed to allow flushing of the pipework system. The by-pass can be used during maintenance to isolate the cooler without disrupting flow to other units.
5. As an aid to servicing, thermometers and pressure gauges should be installed in the inlet and outlet water lines.
6. The chilled water lines that are exposed to outdoor ambient should be wrapped with supplemental heater cable and insulated to protect against freeze-up during low ambient periods, and to prevent formation of condensation on lines in warm humid locations.
7. The cooler is protected by heater mats placed under the insulation, which are powered from the unit control system power supply. During cold weather when there is a risk of freezing, unit power should be left switched on to provide the freeze protection function unless the liquid systems have been drained.
8. A chilled water flow switch is already installed in the leaving water piping of the cooler. If the units are modularized, it is recommended to install another flow switch in main liquid leaving pipe. There should be a straight horizontal run of at least 5 diameters on each side of the switch. Adjust the flow switch paddle to the size of the pipe in which it is to be installed (see manufacturer's instructions

furnished with the switch).



**The Flow Switch *MUST NOT* be used to start and stop the unit (i.e. starting and stopping the chilled water pump). It is intended only as a safety switch.**

## PIPEWORK ARRANGEMENT

The units are able to be connected in a pipe network for centralized control. The control system is designed to work effectively within a maximum of 32 control boards (communication addresses) connected. Follow the arrangements below for combinations.

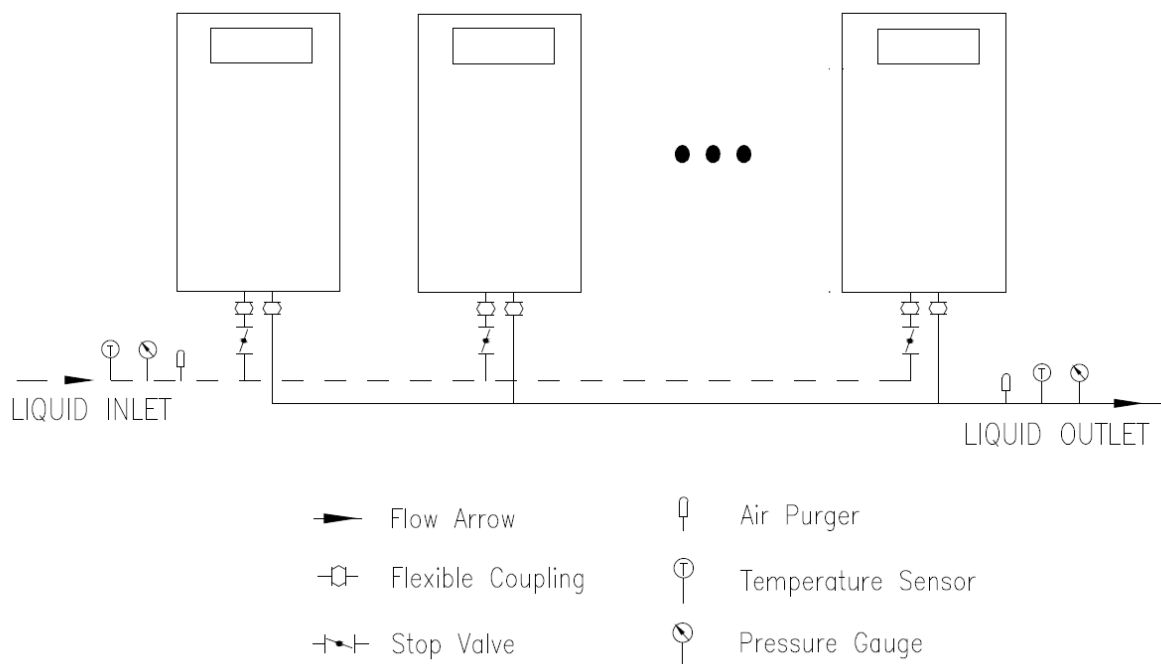

## Notes

1. Placement on a level surface free of obstructions (including snow, for winter operation) or air recirculation ensures rated performance, reliable operation and ease of maintenance.
2. Site restrictions may compromise minimum clearances indicated below, resulting in unpredictable air flow patterns and possible diminished performance. York's unit controls will optimize operation without nuisance high pressure safety cutout; however, the system designer must consider potential performance degradation.
3. The distances between the walls and peripheral units should employ the same rules as shown in Dimensions section, if the units are surrounded by walls
4. No more than one adjacent wall may be higher than the unit.
5. Installing contractor must include vent and drain accommodations in chilled water piping near the

evaporator.

6. Stop valves must be installed at the inlet of each unit to balance chilled liquid distribution.
7. A minimum interval must be reserved for field wiring, commissioning and maintenance.
8. Refer to single unit drawings for detailed dimensions.

## **WIRING**

The units are shipped with all factory-mounted controls wired for operation.

Field Wiring – Power wiring must be provided through a protector device (fused disconnect switch or circuit breaker) to the input unit terminals in accordance with local code requirements. Maximum current is given in Electrical Data.

Copper power wiring only should be used for supplying power to the unit. This is recommended to avoid safety and reliability issues resulting from connection failure at the power connections to the unit. Aluminum wiring is not recommended due to thermal characteristics that may cause loose terminations resulting from the contraction and expansion of the wiring.

Aluminum oxide may also build up at the termination causing hot spots and eventual failure. If aluminum wiring is used to supply power to the unit, AL-CU compression fittings should be used to transition from aluminum to copper. This transition should be done in an external box separate to the power panel.

Copper conductors can then be run from the box to the unit.

See unit wiring diagrams for field and power wiring connections, communication wiring connections, modular wiring, alarm contacts, remote start/stop input, remote cooling/ heating switch, etc. Refer to UNIT OPERATION for a detailed description of operation concerning aforementioned contacts and inputs.

### **Pump Start Contacts**

Terminal block XTB2 – terminals 21 to 22, are normally open contacts that can be used to switch field supplied power to provide a start signal to the pump contactor. User-provided pump contactor and thermal relay are required if the pump is field installed. The contacts will be closed when any of the following conditions occur:

1. Any compressor is running
2. The unit(s) is on and no flow fault occurred
3. Anti-freezing operation
4. Pump circulation mode

The pump will not run if the micro panel has been powered up for less than 30 seconds, or if the pump has run in the last 30 seconds, to prevent pump motor overheating. Refer to unit wiring diagram.

### **Alarm Status Contacts**

Normally-open contacts are available for each unit. These normally-open contacts remain open when



the system is functioning normally. The respective contacts will close when the unit is shut down on a unit fault, or locked out on a system fault. For modular applications, the master unit will not only output internal fault, but also the fault of subordinate units. Field connections are at XTB2 terminals 23 to 24.

### **Remote Start/ Stop Contacts**

To remotely start and stop the unit, dry contacts can be wired to XTB2 terminals 80G to 87. Refer to unit wiring diagram.

The function will be available after being activated through HMI.

### **Remote Cooling/ Heating Switch**

The contacts are used to switch unit operating mode remotely.

Dry contacts can be wired to XTB2 terminals 80F to 86. Refer to unit wiring diagram.

The function will be available after being activated through HMI.

### **Flow Switch Input**

For modular combinations, it is recommended to install an additional flow switch in outlet main pipe. The switch is to be wired to terminals 80E – 85 of XTB2 located in the control panel, as shown on the unit wiring diagram.

### **External Interlock**

The unit will be allowed to run only if the interlock is connected. It is used to link external facilities like fire alarms in case there's an emergency cutoff. It is wired to terminals 80H - 88 on block XTB2.

Make sure External Interlock is short-circuited or is linked to external facilities before operation.

### **COMPRESSOR HEATERS**

Compressor heaters are standard. All compressors utilize two heaters with 40 W each.

If the unit is powered on for the first time, the crankcase heaters must be energized for at least 8 hours prior to restarting a compressor. This will assure that liquid slugging and oil dilution does not damage the compressors on start.

### **PRESSURE CUTOUT**

One high pressure cutout and two low pressure cutouts (one LP cutout for cooling only unit) are installed in the discharge and suction piping of each system. The HP cutout opens at 4.03 MPa (585 PSIG) and closes at 3.1 MPa (450 PSIG). The cooling LP cutout opens at 0.3 MPa (44 PSIG) and closes at 0.5 MPa (73 PSIG). The heating LP cutout opens at 0.15MPa (22 PSIG) and closes at 0.3 MPa (44 PSIG).

### **WIRE CONTROLLER**

Dual HMI is available on YCAE. Once the function is activated, the chip will automatically overwrite the memory by the latest settings sent from either of the controllers.





---

## SC-EQUIPMENT COMMUNICATION CARD

The SC-EQ (Smart Chiller Equipment) Communication Card is an economical and versatile communications device that provides a communication connection between the unit and standard open BAS protocols. It efficiently manages all of the communication protocols used by York equipment, exposing the data in a consistent, organized, and defined fashion.

The SC-EQ Communication Card is available as a card that is already fitted directly inside the control panel. The SC- EQ detects the model of the unit and the BAS protocol and then automatically configures itself to communicate with both.

## POWER SUPPLY CONNECTION

### Electrical Legends

#### ABBREVIATIONS OF ELECTRICAL COMPONENTS – YCAE065X

FMC1/2	电机保护电器 OVERLOAD RELAY	QF/QF1	断路器 BREAKER
KM4/5/6	风机电机交流接触器 FAN MOTOR CONTACTOR	TB1/2	端子 TERMINAL BLOCK
MC1/2	压缩机 COMPRESSOR MOTOR	PSF	电源故障 POWER FAULT
MF1/2	风机电机 FAN MOTOR	KM1/2	压缩机交流接触器 COMPRESSOR MOTOR CONTACTOR
CH1/2/3/4	曲轴箱加热带 CRANKCASE HEATER	LPS1	低压压力传感器 LOW PRESSURE SENSOR
KA1	中间继电器 RELAY	HPS1	高压压力传感器 HIGH PRESSURE SENSOR
AP1	主板 MAIN BOARD	FLS2	模块水流开关 MODULE FLOW LIQUID SWITCH
AP3	线控器 WIRE CONTROLLER	EXV1	电子膨胀阀 EXV
RT1	系统回水温度传感器 SYSTEM RETURN WATER TEMPERATURE	FV	四通阀 FOUR-WAY SOLENOID VALVE
RT2	环境温度传感器 AMBIENT TEMPERATURE SENSOR	AL	报警 ALARM
RT3	翅片温度传感器 DEFROST TEMPERATURE	KM3	水泵控制线圈 PUMP HEATER
RT5	模块出水温度 MODULE LEAVING WATER TEMPERATURE	KM7	辅助水加热线圈 ADDITIONAL WATER HEATER
RT6	系统出水温度传感器 SYSTEM LEAVING WATER TEMPERATURE	KT2/3	风机过载 FAN OVERLOAD
RT7	1#进气分温度传感器 1# ACCUMULATOR INLET TEMPERATURE	FLS1	水流开关 FLOW LIQUID SWITCH
RT9	1# 排气温度传感器 1# COMPRESSOR DISCHARGE TEMPERATURE	C/H	冷热切换 COOL/HEAT
RT10	2# 排气温度传感器 2# COMPRESSOR DISCHARGE TEMPERATURE	REMOTE	遥控开关 REMOTE
RT9	1# 排气温度传感器 1# COMPRESSOR DISCHARGE TEMPERATURE	EXT	外部连锁 EXTERNAL LOCK
RT10	2# 排气温度传感器 2# COMPRESSOR DISCHARGE TEMPERATURE	LP1	低压压力 LOW PRESSURE
RT10	2# 排气温度传感器 2# COMPRESSOR DISCHARGE TEMPERATURE	HP1	高压压力 HIGH PRESSURE
代码 CODE	描述 DESCRIPTION	代码 CODE	描述 DESCRIPTION

#### ABBREVIATIONS OF ELECTRICAL COMPONENTS – YCAE100/130X

CODE	DESCRIPTION	CODE	DESCRIPTION	CODE	DESCRIPTION
-YMEV	MAIN EEV	-MC	COMPR MOTOR	-FHP	HIGH PRESS SWITCH
-YWSV	WATER SOL VALVE	-KWP	WATER PUMP RELAY	-EPH	WATER PIPING HEATER
-YMSV	MODE SOL VALVE	-KPW	POWER FAULT RELAY	-EEPH	PHE PIPING HEATER
-XTB	TERMINAL BLOCK	-KPF	POWER PROTECTOR	-EEH	PHE HEATER
-T	TRANSFORMER	-KM	COMPR CONTACTOR	-ECH	CRANK CASE HEATER
-SRE	REMOTE START SWITCH	-KFS	FAN SPEED RELAY	EXT	EXTERNAL PART
-SF2	SYSTEM FLOW SWITCH	-KFP	FR & FHP RELAY	-BSP	SUCTION PRESS
-SF1	MODULE FLOW SWITCH	-KFL	FAN LOW SPEED CONTACTOR	-BDP	DISCHARGE PRESS
-SEM	EMERGENCY BUTTON	-KFH	FAN HIGH SPEED CONTACTOR	-BLMT	LEAVING MODULE TEMP
-SEL	EXTERNAL INTERLOCK SWITCH	-KF	FAN CONTROL CONTACTOR	-BLST	LEAVING SYSTEM TEMP
-SC/H	COOLING/HEATING SWITCH	-KEM	EMERGENCY RELAY	-BEST	ENTERING SYSTEM TEMP
-RC	RC ABSORBER	-KCH11	INV COMPR HTR RELAY	-BDT	DISCHARGE TEMP
-QMCB	MAIN CIRCUIT BREAKER	-KAL	ALARM RELAY	-BAMB	AMBIENT TEMP
-QCB	CIRCUIT BREAKER	-KAH	AUX HEATER CONTACTOR	-BACDT	AIR COIL DEFROST TEMP
PE	PROTECTIVE EARTH	-H1	ALARM LAMP	-BAIT	ACCUMULATOR INLET TEMP
-MP	PUMP MOTOR	-FR	OVERLOAD RELAY	-AMGB	MODBUS GATEWAY BOARD
-MF	FAN MOTOR	-FLP*2	HEATING LOW PRESS SWITCH	-AMB	MAIN BOARD
-MDF	DRIVER FAN MOTOR	-FLP*1	COOLING LOW PRESS SWITCH		

## Power Supply Connection – Single Unit

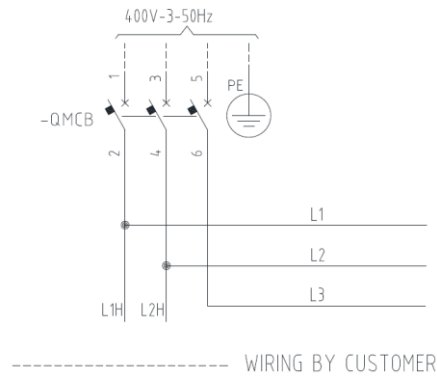

## Power Supply Connection – Modular

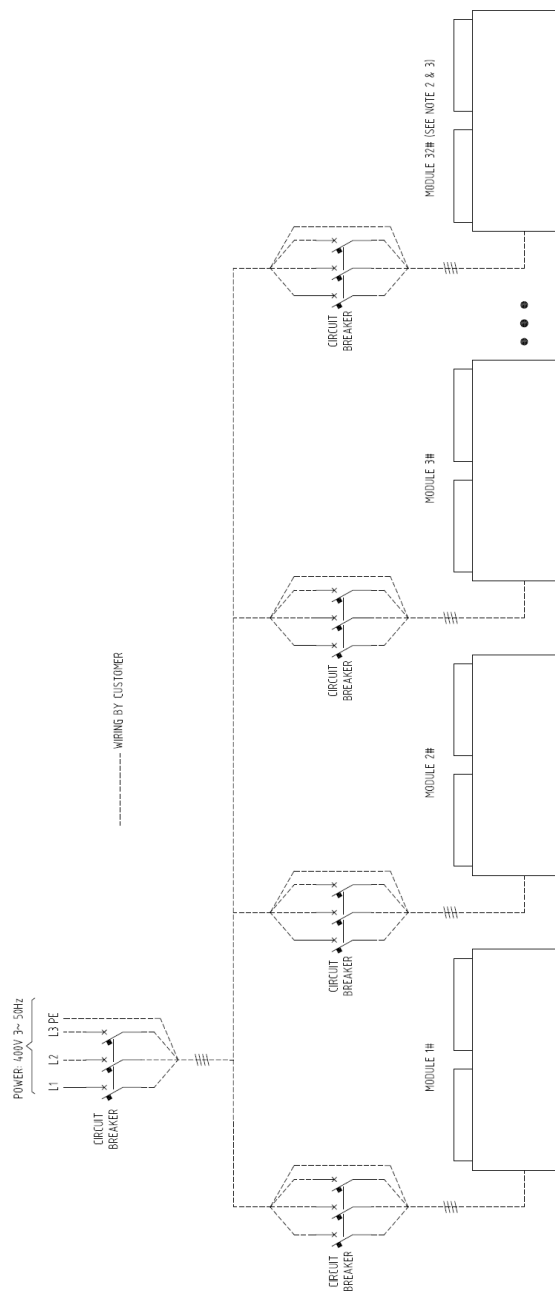

## Notes

1. Power wiring must be provided through a protect device (fused disconnect switch or circuit breaker) to the input terminals of the unit in accordance with CE or local code requirements.
2. Every control board is assigned with one ID address. If a single module includes two control boards, then two ID addresses have to be assigned in the module. The modules above 130 kW have two control boards in the panel.
3. The maximum quantity of modules above 130 kW combined should be 16. The quantity of modules in the same communication network is based on the sum total of control boards in the network.



**Disconnecting 230VAC power from the unit, at or below freezing temperatures, can result in damage to the evaporator and unit as a result of the chilled liquid freezing.**

## CONTROL WIRING

### Communication Wiring – Wire Controller

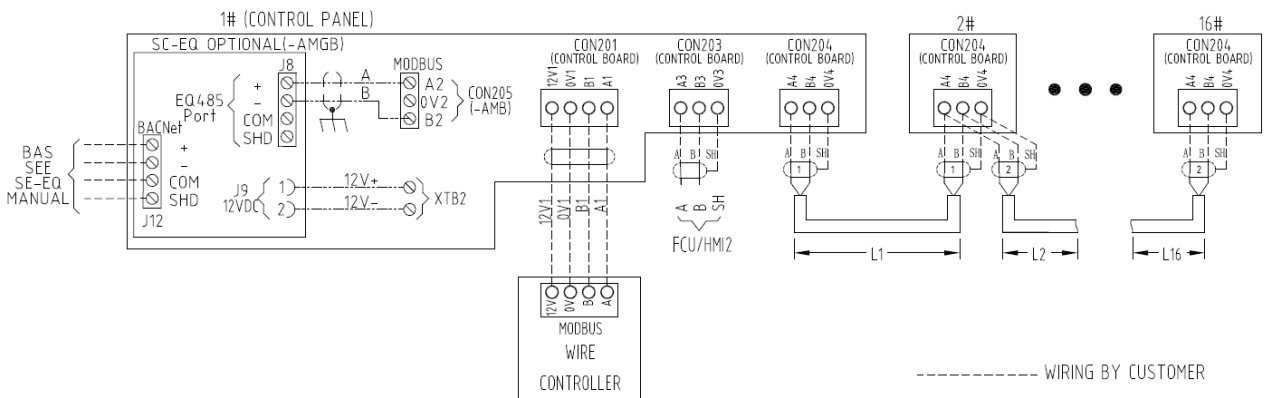

### Communication Wiring – Optiview LT

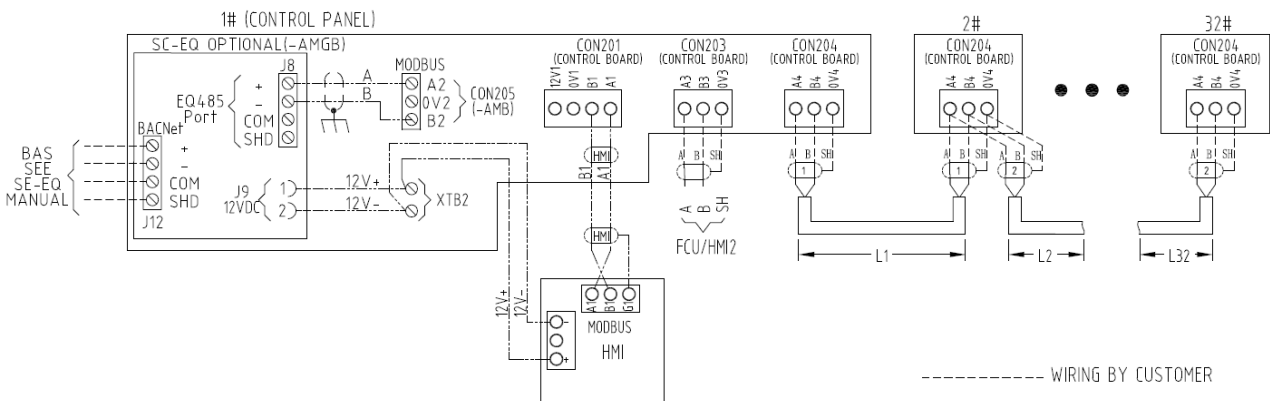

## Note

Optiview LT can also be wired to CON203 if both controllers are needed.

## COMMUNICATION CABLE REQUIREMENT

TOTAL LENGTH	L=L1+L2+L3+...+Ln (n=32 or n=16, unit: m)		
	L < 100 m	100 m < L < 500 m	L > 500 m
CABLE TYPE	RVVPS 2×0.75mm <sup>2</sup>	RVVPS 2×1.0mm <sup>2</sup>	CONTACT JCI SERVICE

### Notes

1. The total length of the communication cable  $L=L_1+L_2+L_3+...+L_n$ . The communication cable should be shielded twisted in pairs. Refer to the table above for cable requirement.
2. Every control board is assigned one ID address.
3. The maximum quantity of the control boards in the same communication network should be 32, and different control boards should use different ID addresses. If not, the control board will be broken.
4. The control boards should not be energized while setting the addresses, or the control board will be broken.
5. Another HMI (wire controller or Optiview LT) can be connected to the communication port CON203 on control board if the DIP switch SW302-8 is set to OFF.

### Field Wirings

#### YCAE065X

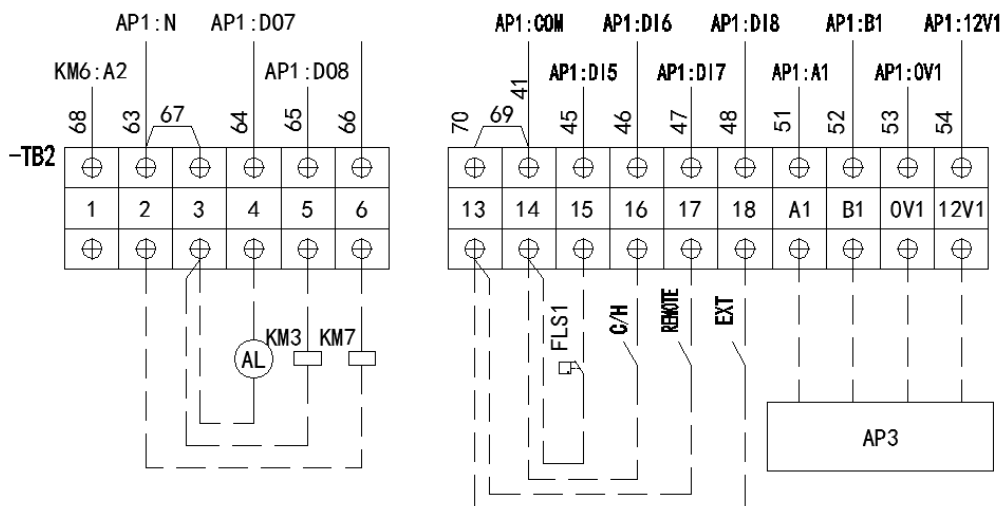

C/H	C/H Switch
REMOTE	Remote Switch
FLS1	System Flow Switch
KT1	Pump Overheat Relay
EXT	External Interlock
KM3	Pump Control
AL	Fault Output
KM7	Auxiliary Heater
AP3	Wire Controller

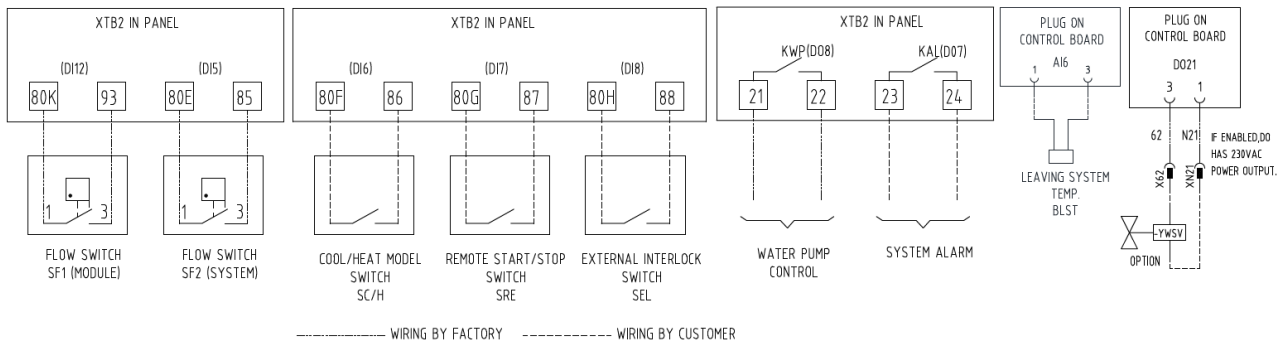

## Notes

1. External interlock is short-circuited or is linked to external facilities before operation;
2. Water pump control is connected by factory before delivery if hydro kit is selected;
3. 45-130 models: SF1 (DI12/XTB2:80K&93) -- Factory installation; SF2 (DI5/XTB2:80E&85) -- Short-circuited before delivery; 160-260 models: SF1 (DI12/XTB2:80K&93) – Short-circuited before delivery; SF2 (DI5/XTB2:80E&85) -- Factory installation;
4. For digital input signals (SF1/SF2, SC/H, SRE, SEL), the loop resistance should be less than 100Ω when the external contact closes. The voltage at both ends of DI switch is 12VDC when DI switch/signal opens;
5. For output signals, the output from the control board is active signal with 230VAC, and the accepted Amps capacity is 1A; For pump/alarm output, a relay (KWP/KAL) has been connected to the output port on control board before delivery to transfer active signal to free contact, and the contact capacity is 1A @250VAC.
6. For additional information, please see wiring diagram.



***It is possible that multiple sources of power can be supplying the unit power panel. To prevent serious injury or death, the technician should verify that NO LETHAL VOLTAGES are present inside the panel AFTER disconnecting power, PRIOR to working on equipment.***

## SECTION 5 – TECHNICAL DATA

### PHYSICAL DATA

Model			YCAE065X	YCAE100X	YCAE130X
Rated Cooling Capacity		kW	65.0	100.0	130.0
Rated Heating Capacity		kW	66.0	100.7	131.9
Refrigerant Charge		kg	12.5	8.3+11.5	11.5×2
Rated Power Input	Cooling	kW	20.4	29.2	39.3
	Heating	kW	20.0	31.0	42.8
Rated Current	Cooling	A	38	55	74
	Heating	A	37	58	80
Compressor	Type	-	Scroll	Scroll	Scroll
	Qty.	PCS	2	3	4
Fan	Qty.	PCS	2	2	2
	Power Input	kW	1.8	0.87+1.65	1.65*2
Cooler	Type	-	BPHE	BPHE	BPHE
	Flow Rate	m <sup>3</sup> /h	11.18	17.2	22.36
Connection	Type	-	Thread	Victaulic	Victaulic
	Diameter	-	DN50	DN65	DN65
Water Pressure Drop		kPa	61	50	60
Dimension	L	mm	1650	2250	2250
	W	mm	760	1200	1200
	H	mm	1700	2420	2420
Weight	Shipping	kg	519	898	1016
	Operation	kg	503	864	982

#### Notes

The units are tested in compliance with GB/T 18430.1:

1. Cooling condition: LWT 7°C, water flow rate 0.172m<sup>3</sup>/(h.kW), ambient temperature 35°C ;
2. Heating condition: LWT 45°C, water flow rate 0.172m<sup>3</sup>/(h.kW), ambient temperature 7/6°C.

---

**ELECTRICAL DATA**

Model	YCAE065X	YCAE100X	YCAE130X
Power Supply	380V 3N~ 50Hz	380V 3N~ 50Hz	380V 3N~ 50Hz
Voltage Range	342V~418V	342V~418V	342V~418V
MCC	52A	85A	112A
Breaker	63A 4P	100A 3P	160A 3P
Power Cable	10 mm <sup>2</sup>	25 mm <sup>2</sup>	35 mm <sup>2</sup>

**Notes**

1. Above specifications of wirings and circuit breakers are based on 40°C ambient temperature. Please refer to local rules for details.
2. If there are any differences in field (any derating conditions), please refer to IEC standards to select cables.

**ELECTRICAL DIAGRAM**

All electrical wiring should be carried out in accordance with local regulations. Route properly sized cables to the cable entries in the bottom of the power panel.

It is the responsibility of the user to install over current protection devices between the supply conductors and the power supply terminals on the unit.

To ensure that no eddy currents are set up in the power panel, the cables forming each 3 phase power supply must enter via the same cable entry.

**YCAE065X**



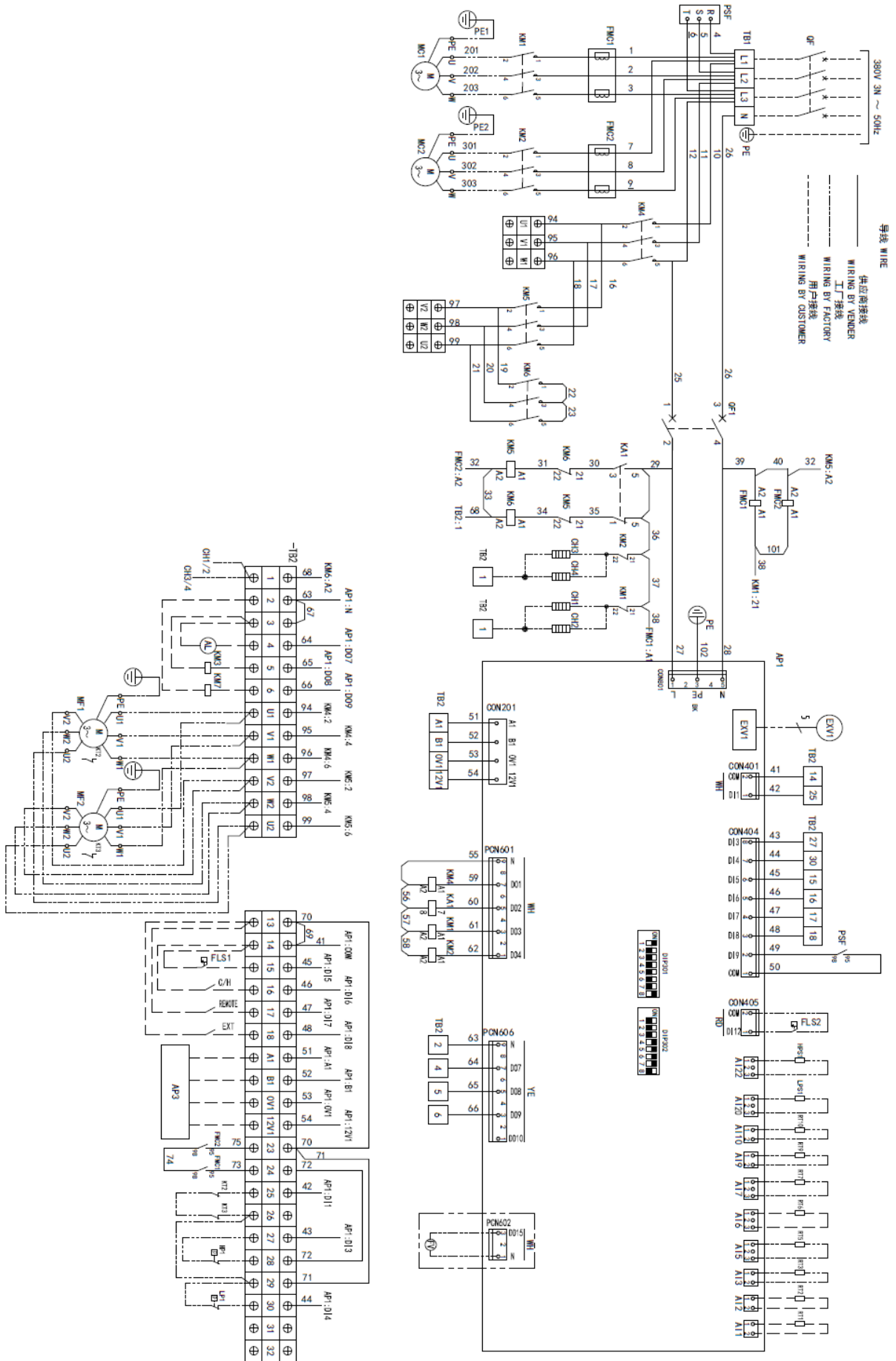

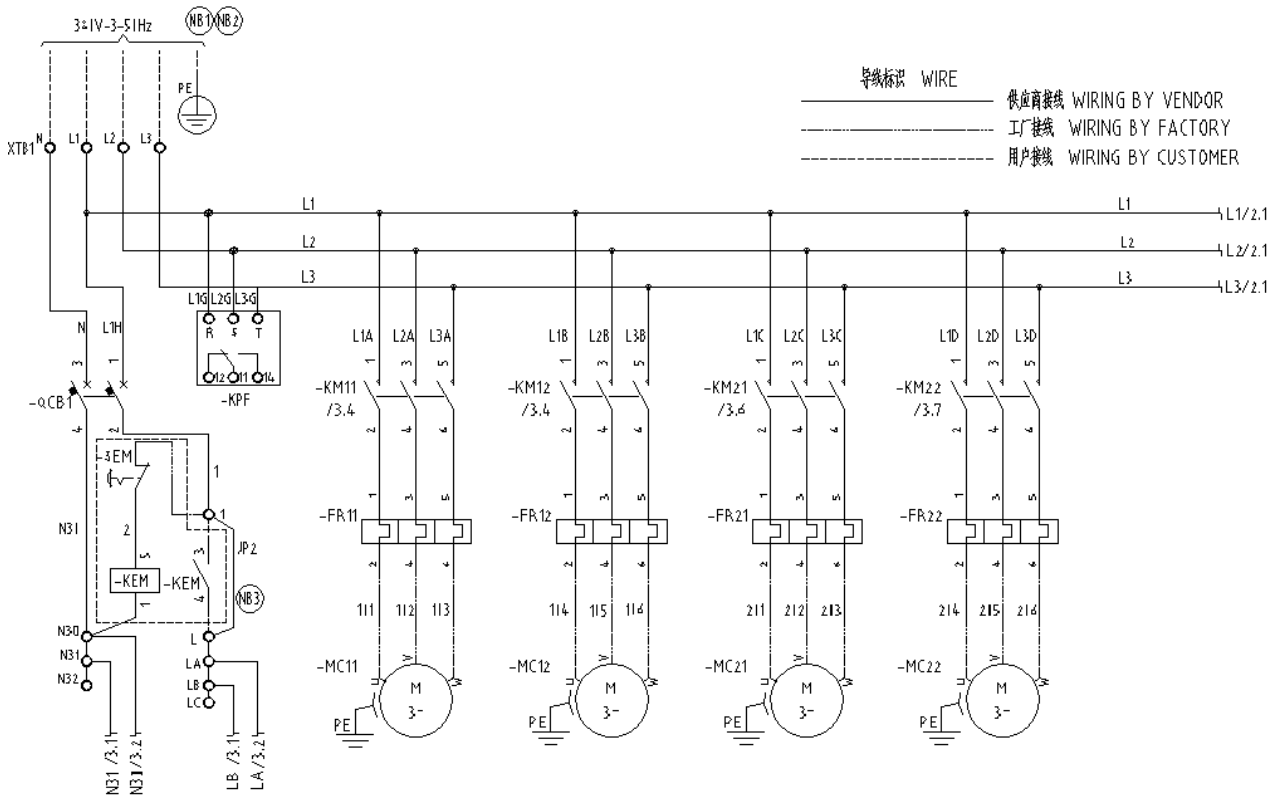

导线标识 WIRE

———	供应商接线	WIRING BY VENDOR
-----	工厂接线	WIRING BY FACTORY
-----	用户接线	WIRING BY CUSTOMER

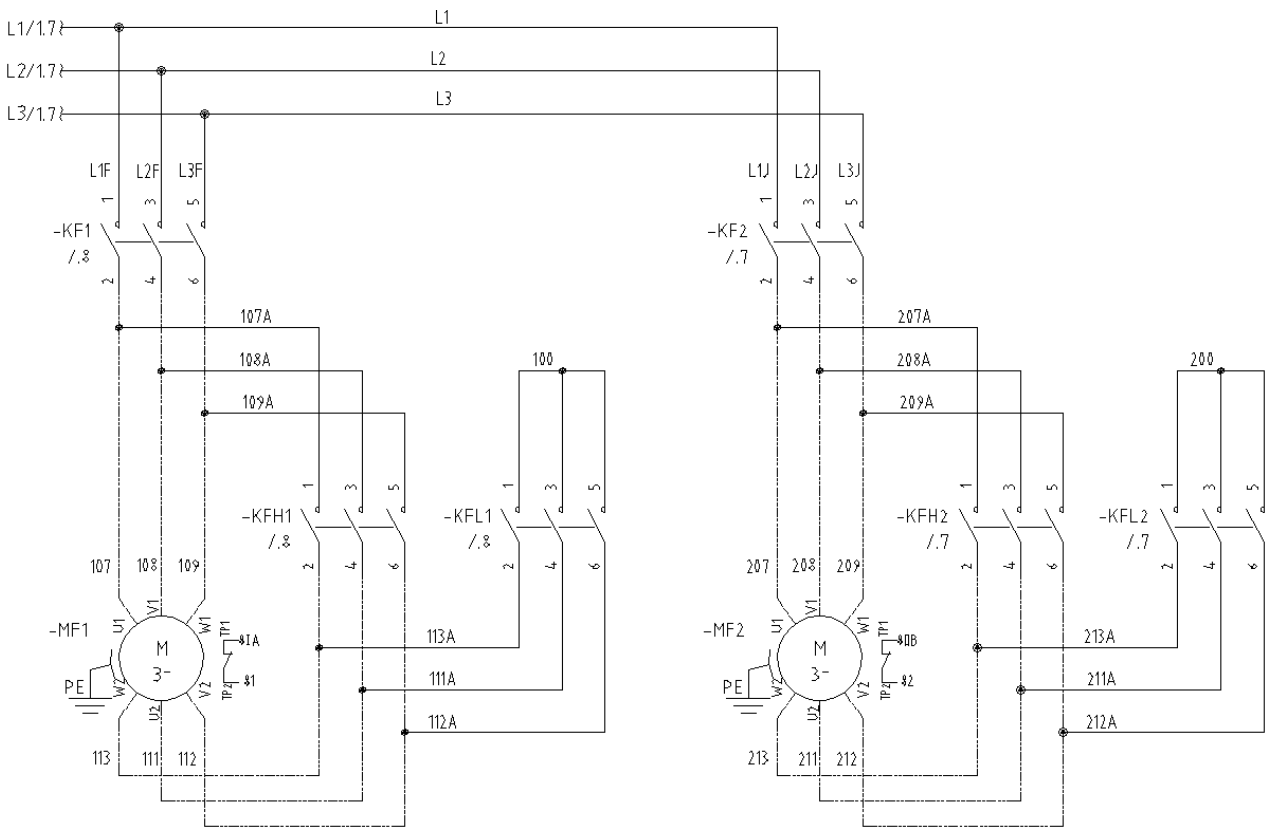

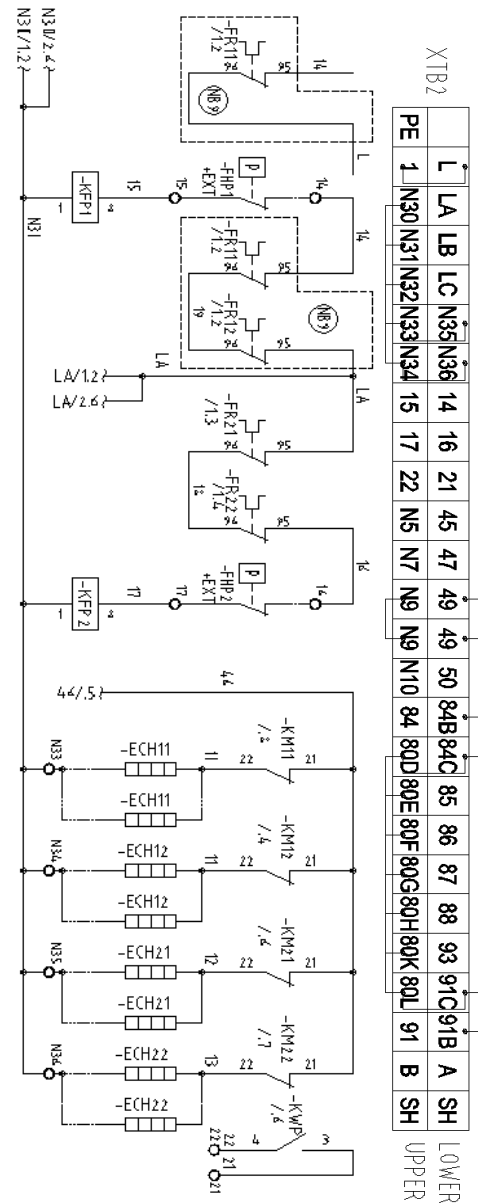
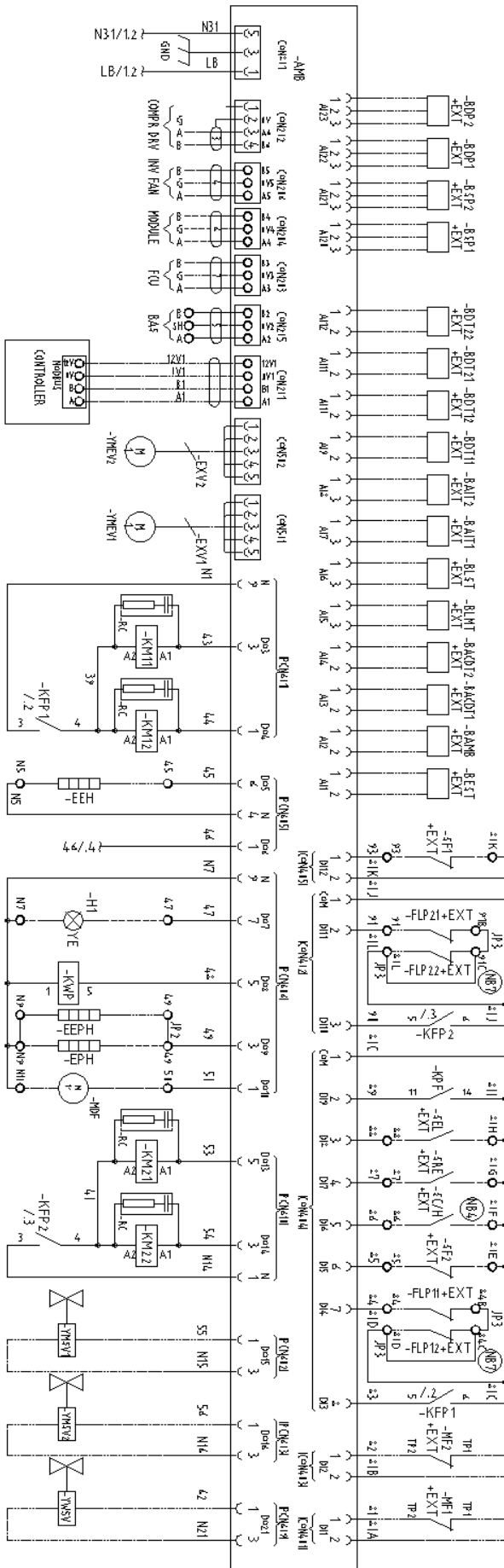

## DIP SWITCH SETTING

### Microboard DIP Switch

Two DIP switches, SW301 and SW302, are located on the IPU3 micro board. SW301 is an eight-digit switch and the first five digits are used to set communication addresses for each module. It is converted from decimalism to binary.

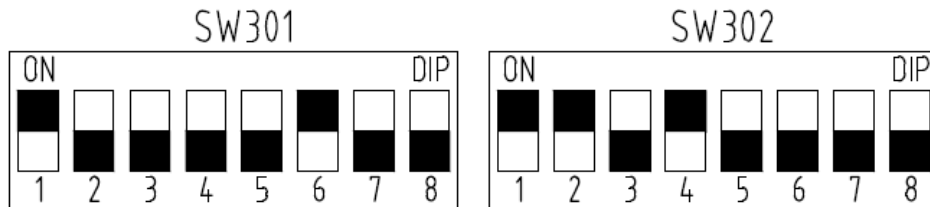

### Address Setting

The control system allows a maximum of 32 micro boards combined as a communication network. The addresses are set as follows.

MODULE	SW301-1	SW301-2	SW301-3	SW301-4	SW301-5
1#	ON	OFF	OFF	OFF	OFF
2#	OFF	ON	OFF	OFF	OFF
3#	ON	ON	OFF	OFF	OFF
4#	OFF	OFF	ON	OFF	OFF
5#	ON	OFF	ON	OFF	OFF
6#	OFF	ON	ON	OFF	OFF
7#	ON	ON	ON	OFF	OFF
8#	OFF	OFF	OFF	ON	OFF
9#	ON	OFF	OFF	ON	OFF
10#	OFF	ON	OFF	ON	OFF
11#	ON	ON	OFF	ON	OFF
12#	OFF	OFF	ON	ON	OFF
13#	ON	OFF	ON	ON	OFF
14#	OFF	ON	ON	ON	OFF
15#	ON	ON	ON	ON	OFF
16#	OFF	OFF	OFF	OFF	ON
17#	ON	OFF	OFF	OFF	ON
18#	OFF	ON	OFF	OFF	ON
19#	ON	ON	OFF	OFF	ON
20#	OFF	OFF	ON	OFF	ON
21#	ON	OFF	ON	OFF	ON
22#	OFF	ON	ON	OFF	ON
23#	ON	ON	ON	OFF	ON
24#	OFF	OFF	OFF	ON	ON
25#	ON	OFF	OFF	ON	ON

26#	OFF	ON	OFF	ON	ON
27#	ON	ON	OFF	ON	ON
28#	OFF	OFF	ON	ON	ON
29#	ON	OFF	ON	ON	ON
30#	OFF	ON	ON	ON	ON
31#	ON	ON	ON	ON	ON
32#	OFF	OFF	OFF	OFF	OFF

### Model and Function Setting

The last 3 digits of SW301 are used to set models.

Model	SW301-6	SW301-7	SW301-8
065	OFF	OFF	ON
100	OFF	ON	ON
130	ON	OFF	OFF

The digits of SW302 are used to set the configurations of the unit. This is already finished before unit delivery.

<b>SW302-1</b>	OFF	
<b>SW302-2</b>	OFF	
<b>SW302-3</b>	OFF	Only available for 1# unit
<b>SW302-4</b>	ON	Only available for 1# unit
<b>SW302-5</b>	OFF: Cooling Only ON: Heat Pump	
<b>SW302-6</b>	ON	Only available for 1# unit
<b>SW302-7</b>	ON	
<b>SW302-8</b>	OFF: HMI2 ON: FCU	FCU: T8600 Thermostat

### Wire Controller DIP Switch

The 6-digit switch used to set the unit type is positioned in the back of the wire controller. The DIPs are preset in accordance with Microboard before delivery.

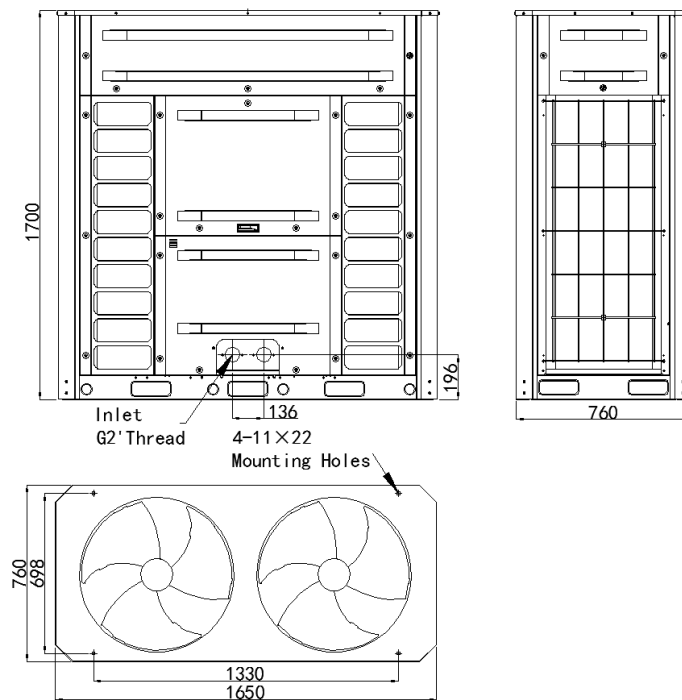
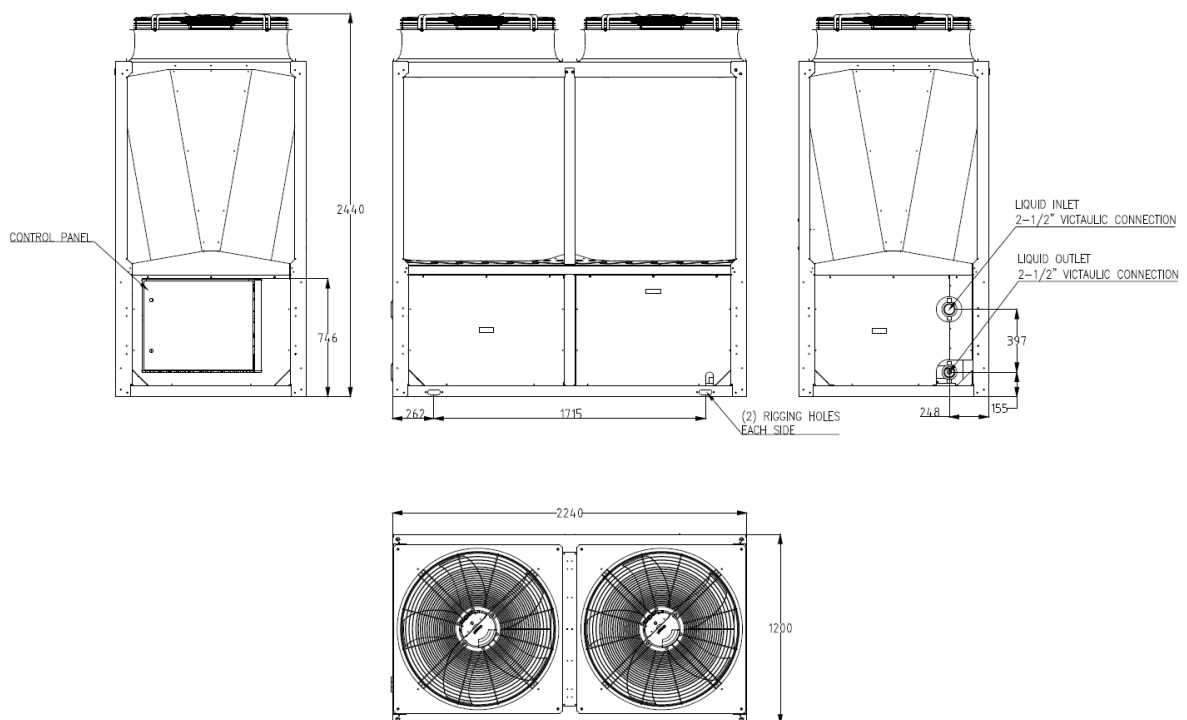
**DIMENSIONS**
**YCAE065X**

**YCAE100/130X**

*All dimensions are in mm unless specified otherwise.*

*The enclosure panels of YCAE100/130X as shown are optional.*

Notes

1. Placement on a level surface of free of obstructions (including snow, for winter operation) or air circulation ensures rated performance, reliable operation, and ease of maintenance.
2. Site restrictions may compromise minimum clearances indicated below, resulting in unpredictable airflow patterns and possible diminished performance.
3. YORK's unit controls will optimize operation without nuisance high-pressure safety cutouts; however, the system designer must consider potential performance degradation.

**CLEARANCES**

**YCAE065X**

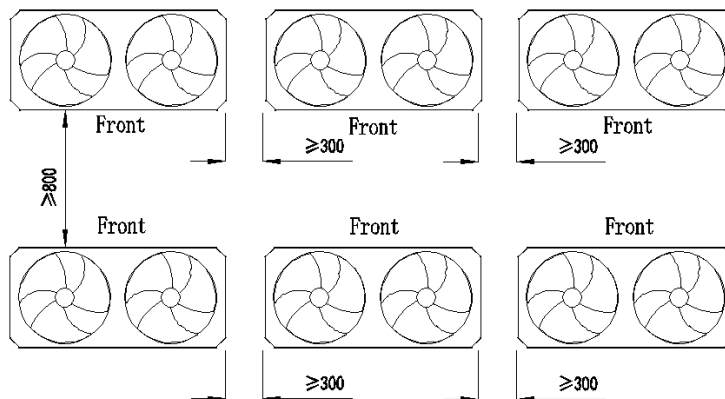

**YCAE100/130X**

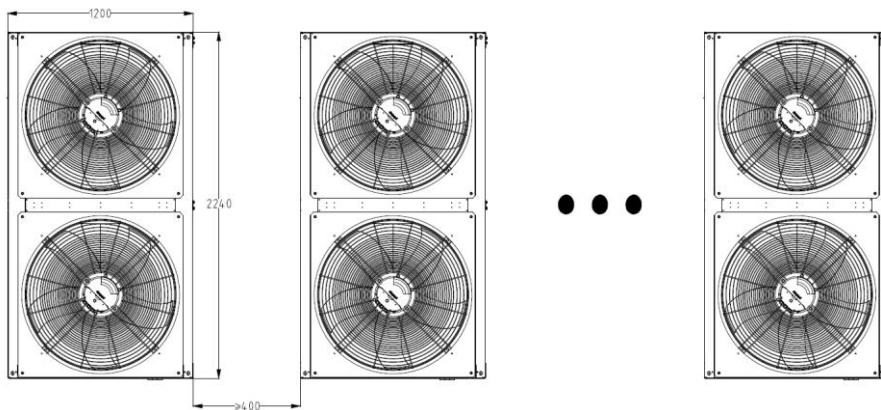

Recommended minimum clearances:

front to wall – 2m; rear to wall – 2m; control panel end to wall – 2m; cooler end to wall – 2m; top – no obstructions allowed; distance between adjacent units – 300mm or 400mm. No more than one adjacent wall may be higher than the unit. 1" nominal deflection isolators (not shown) will increase overall unit height by 150mm.

## SECTION 6 – COMMISSIONING

### COMMISSIONING



***Commissioning of this unit should only be carried out by YORK Authorized personnel.***

Commissioning personnel should be thoroughly familiar with the information contained in this literature, in addition to this section.

Perform the commissioning using the detailed checks outlined in the START-UP CHECK LIST as the commissioning procedure is carried out.

### PREPARATION – POWER OFF

The following basic checks should be made with the customer power to the unit switched OFF.

#### Inspection

Inspect unit for installation damage. If found, take action and/or repair as appropriate.

#### Refrigerant Charge

Packaged units are normally shipped as standard with a full refrigerant operating charge. Check that refrigerant pressure is present in each system and that no leaks are apparent. If no pressure is present, a leak test must be undertaken, the leak(s) located and repaired. Repaired systems must be evacuated with a suitable vacuum pump/recovery unit as appropriate to below 100 microns before charging.



***Do not liquid charge with static water in the cooler. Care must also be taken to liquid charge slowly to avoid excessive thermal stress at the charging point.***

Once the vacuum is broken, charge into the condenser coils with the full operating charge as given in the Technical Data section.

Liquid subcooling measured at the liquid line should be between 5°C and 8°C when unit is operating in cooling mode and fully loaded. Subcooling is determined by the level of refrigerant charge in each system.

#### Compressor Oil

The units are charged with sufficient oil to ensure the effective and reliable operation in full envelope. However, the units may need additional oil charge in field in case leakage is detected or the compressor is being replaced.





To add oil to a circuit – connect a YORK hand oil pump to the 1/4” oil charging connection before the accumulator with a length of clean hose or copper line, but do not tighten the flare nut. Using clean oil of the correct type, pump oil until all air has been purged from the hose then tighten the nut.

Stroke the oil pump to add oil to the oil system. Approximately 1.6 liters is present in single compressor system and 5.0~5.5 liters in tandem compressor system. Too much oil may cause excessive oil carryover in the system. High oil concentration in the system may cause nuisance trips resulting from incorrect readings on temperature sensors. Temperature sensor errors may result in poor liquid control and resultant liquid overfeed and subsequent damage to the compressor.

### **Fans**

Check that all fans are free to rotate and are not damaged. Ensure blades are at the same height when rotated. Ensure fan guards are securely fixed.

### **Isolation / Protection**

Verify all sources of electrical supply to the unit are taken from a single point of isolation. Check that the maximum recommended air switch sizes given in the Technical Data section has not been exceeded.

### **Control Panel**

Check the panel to see that it is free of foreign materials (wire, metal chips, etc.) and clean out if required.

### **Power Connections**

Check that the customer power cables are connected correctly to the terminal blocks or circuit breaker. Ensure that connections of power cables within the panels to the circuit breaker or terminal blocks are tight.

### **Grounding**

Verify that the unit’s protective ground terminal(s) are properly connected to a suitable grounding point. Ensure that all unit internal ground connections are tight.

### **Supply Voltage**

Verify that the site voltage supply corresponds to the unit requirement and is within the limits given in the Technical Data section.

## **PREPARATION – POWER ON**

Apply power to the unit.

### **Water System**

Verify the chilled liquid system has been installed correctly, and has been commissioned with the correct direction of water flow through the cooler. The inlet should be at the higher end of the cooler. Purge air from the top of the water system using the plugged air vent mounted on the top of the piping.

Flow rates and pressure drops must be within the limits given in the Technical Data section. Operation

outside of these limits is undesirable and could cause damage.

If mains power must be switched OFF for extended maintenance or an extended shutdown period, the compressor suction and discharge service stop valves should be closed (clockwise). If there is a possibility of liquid freezing due to low ambient temperatures, the coolers should be drained or power should be applied to the unit. Before placing the unit back in service, valves should be opened and power must be switched on (if power is removed for more than 8 hours) for at least 8 hours before the unit is restarted.

### **Flow Switch**

A unit flow switch has been fitted on the cooler outlet. If the units are connected for central control, it is recommended to install an additional flow switch on the main outlet. Make sure the switch is wired into the control panel correctly using shielded cable.

There should be a straight run of at least 5 pipe diameters on either side of the flow switch.

### **Temperature Sensor(s)**

Leaving liquid temperature sensor is used for modular control. Ensure the sensor is coated with heat conductive compound and is inserted to the bottom of the water outlet sensor well in the main pipe. This sensor also provides some anti-freezing protection and must always be fully inserted in the water outlet sensor well.

### **Control Supply**

Verify the control panel display is illuminated.

## **UNIT OPERATING SEQUENCE**

The operating sequence described below relates to operation on a starting process after power has been applied, such as start-up commissioning. When a compressor starts, internal timers limit the minimum time before another compressor can start to 40 seconds (20-120 seconds, adjustable).

1. When power is applied to the system, the micro-processor will perform a pre-check to ensure that the daily/holiday schedule and any remote interlocks will allow the unit to run, all safety cut-outs are satisfied and no faults are unsettled. Any problems found by the pre-check will be displayed if present.
2. For the unit to run, there must be an 'ON' command given by controller or BAS (Building Automation System) for the unit to respond to. Once the unit is ON, the water pump contactor will close instantly. The unit will then detect the status of the flow switch to ensure sufficient liquid flow is supplied.
3. If no problems are present and duty is required the compressor will start. After an initial period of operation with the compressor, the control system will adjust the unit load depending on the liquid temperature and rate of temperature change. If high load is present, the controller will start the next compressor. If very little load is present, the compressor may continue to operate or may simply stop. If the latter is the case, one compressor will restart automatically should the liquid temperature require.
4. When a compressor is running the controller monitors suction pressure and various other system parameters such as discharge pressure, liquid temperature, etc. Should any problems occur, the control system will immediately take appropriate action and display the nature of the fault.

- 
5. The corresponding condenser fan will be cycled on when compressor starts.
  6. Each system is fitted with an EEV (electrical expansion valve) in the liquid line between condenser coil and cooler. The device will automatically adjust the steps to satisfy refrigerant flow demand, based on the difference between actual and target superheat. There is a pre-adjustment of the opening before compressor loading up or shutting down within one refrigerant circuit.
  7. If demand requires, another system (for dual circuit units), or another unit (for modular control), will cycle on with the same timing sequences. Refer to the section on Liquid Temp. Control for a detailed explanation of system and compressor staging.
  8. As the load decreases below setpoint, the compressors will be shut down in sequence. This will normally occur at intervals of 40 seconds based on water temperature as compared to setpoint and the rate of temperature change. See the section on Liquid Temp. Control for a detailed explanation.
  9. When the last compressor in a “system” (one or two compressors per system), is to be cycled off, the system will switch off its fan and EEV shortly afterwards.
  10. The unit can be stopped at any time by switching. The compressor heaters will energize to prevent refrigerant condensing in the compressor rotors and to prevent the compressor oil becoming saturated with refrigerant.
  11. If mains power must be switched off (for extended maintenance or a shutdown period), the compressor suction and discharge service valves on both systems should be closed (clockwise) and if there is a possibility of liquid freezing due to low ambient temperatures, the heat exchanger should be drained. The valves should be opened, the heat exchanger refilled and the power must be switched on for at least 8 hours before the unit is restarted.

## SECTION 7 – WIRE CONTROLLER OPERATION



**Don't touch the screen with sharp points or edges which may damage the controller. Don't twist or pull the wires of the controller. Don't wipe the controller with benzene, diluent or chemical cloth. Otherwise discoloration or mechanical failure may occur. To remove dirt, dip the cloth in the water with a neutral detergent and wring the water before cleaning. Wipe dry the controller with dry cloth. Do not exert excessive force on the display or connection in order to avoid changes in hue.**

### INTRODUCTION

The touch screen wire controller is standard for remote controls of YCAE units. The functions of parameter setting, operating status viewing and fault recording are available. Instead of describing the information above, the wire controller utilizes graphic icons in user interface.

### INTERFACE

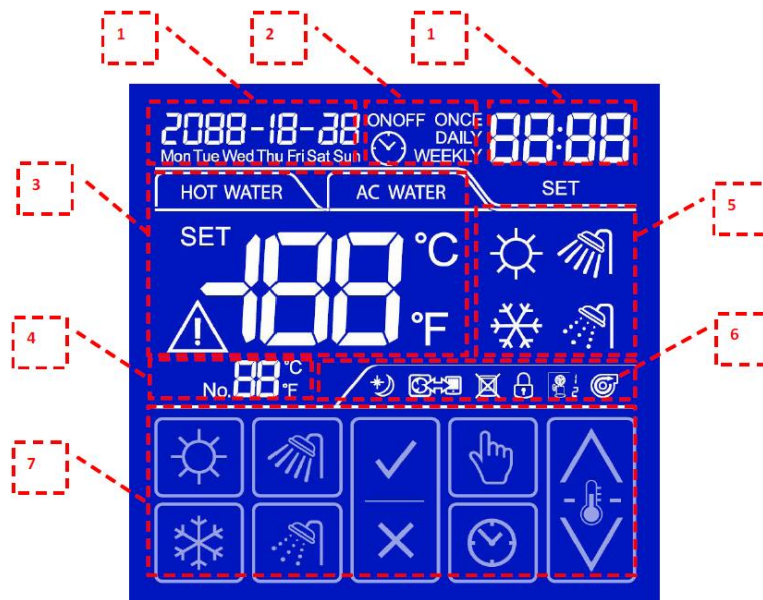

Area 1: Date and time display;

Area 2: Timer display;

Area 3: Temperature display (include the set point and actual controlled water temperature);













Area 4: Serial number display;

Area 5: Operating mode setting;

Area 6: Running status display;

Area 7: Touch-keys.

The meanings of the icons are listed in Table 30.

KEY	MEANING	KEY	MEANING	KEY	MEANING
	COOLING		FUNCTION		FAULT
	HEATING		TIMER		PUMP
	CONFIRM		UP		LOCK
	CANCEL		DOWN		LOW SOUND

## BASIC OPERATIONS

### Start and Stop the Unit

Press the button below the screen to start or stop the unit.



### Operating Mode

Press the key of “COOLING” or “HEATING” to set or switch operating modes. The “SET” icon will be showing during the process. Press “CONFIRM” to finish the setting, or the controller will autosave if there’s no operation for 10 seconds.

Press “CANCEL” to abandon the setting.

### Liquid Temperature Setpoint

Press “UP” or “DOWN” key in daily display screen to set target liquid temperatures. Press “CONFIRM” to finish the setting, or the controller will autosave if there’s no operation for 10 seconds. Press “CANCEL” to abandon the setting.

## ADVANCED OPERATIONS

### Date and Time

Press the “TIMER” and “FUNCTION” keys simultaneously for 5 seconds to enter the Date and Time setting screen. The “TIMER” and “SET” icons will flicker while the function is activated.



Press "TIMER" to toggle between Year, Month, Day, Hour and Minute. Press "UP" and "DOWN" icons to modify the values.

Touch and hold the icons to increase or decrease the values by 5 each time.

Press "CONFIRM" to save the value and auto switch to the next setting. Press "TIMER" to cancel the operation and auto switch to the next setting.

The setting will terminate if there's no operation for 5 seconds or "CANCEL" is pressed.

### **Schedule Timer**

Press the "TIMER" key for 5 seconds to enter Schedule Timer setting screen. The "TIMER", "SET" and "ON" icons will flicker while the function is activated.

The Schedule Timer will toggle between Timer ON, Timer OFF and Timer Mode.

Press "FUNCTION" to select Hour and Minute which are able to be set by "UP" and "DOWN" keys. Once the setting is finished, press "CONFIRM" to save the value and auto switch to the next setting. Press "TIMER" to cancel the operation and auto switch to the next setting.

In Timer Mode setting, press "FUNCTION" to switch the modes between ONCE, DAILY and WEEKLY. Press "CONFIRM" to save the value and auto switch to the next setting. Press "TIMER" to cancel the operation and auto switch to the next setting.

In WEEKLY timer setting, the weekdays are able to be switched over by pressing "FUNCTION" key. Press "UP" to "CONFIRM" the weekday timer activation and move on to the next weekday. Press "DOWN" to cancel the activation of the weekday and move on to the next.

The Schedule Timer setting will terminate if there's no operation for 5 seconds or "CANCEL" is pressed.

### **Parameter Setting**

Press the "FUNCTION" key in daily display for 5 seconds to enter System Parameter Setting screen. Repeat the operation to enter Module Parameter Setting screen. The "LOCK" icon will appear while the function is activated.

In System Parameter Setting, the parameters will be displayed in hour display area (Area 1) in sequence by pressing "FUNCTION" key.

In Module Parameter Setting, the modules can be switched over by pressing "TIMER" key.

Press "UP" or "DOWN" to set the value and press "CONFIRM" to save the value. The setting will terminate if there's no operation for 5 seconds or "CANCEL" is pressed.

### **Fault Diagnosis**

Press "FUNCTION" and "CANCEL" keys for 5 seconds to enter Fault Diagnosis. The "FAULT" icon will appear while the function is activated.

The fault codes will be displayed in temperature display area (Area 3) with time recorded. The serial number of the module will be displayed as 10-bit of Area 4.

Press “UP” and “DOWN” for more fault information. A maximum of 16 faults can be recorded.

The setting will terminate if there’s no operation for 5 seconds or “CANCEL” is pressed.

### **Running Status**

Press “FUNCTION” and “CONFIRM” keys for 5 seconds to enter Running Status viewing screen. The digital and analog inputs and outputs are displayed in sequence in hour display area (Area 1) by pressing “UP” and “DOWN” keys.

The modules can be switched over by pressing “TIMER” key.

### **Fault Reset**

Press “CONFIRM” and “CANCEL” keys for 5 seconds to reset the faults manually.

### **Keylock**

Press “TIMER” and “DOWN” icons for 5 seconds to enter Keylock function. The “LOCK” icon will appear and all touchkeys and the physical button will be disabled while the function is activated.

Press “TIMER” and “DOWN” again to terminate the function.

### **Pump Circulation**

Press “COOLING” key for 5 seconds in daily display to enter Pump Circulation function. The “PUMP” icon will appear.

The pump will operate with no compressor running while this function is activated.

### **Low Sound Mode**

Press “CONFIRM” key for 5 seconds in temperature setting display to enable Low Sound Mode. Press “FUNCTION” and “CONFIRM” keys for 5 seconds in temperature setting display to enable Night Low Sound Mode. In Night Low Sound Mode the low sound function will only be activated during 21:00 to 6:00.

### **Manual Defrost**

Press “COOLING” and “FUNCTION” keys for 5 seconds in temperature setting display to enter Manual Defrost setting. The modules can be selected by pressing “TIMER” and defrost will begin once pressing “CONFIRM”.

Press “CANCEL” to terminate this setting.

## SECTION 8 – MAINTENANCE

It is the responsibility of the equipment owner to provide maintenance on the system.

### IMPORTANT

If system failure occurs due to improper maintenance during the warranty period, YORK will not be liable for costs incurred to return the system to satisfactory operation. The following is intended only as a guide and covers only the unit components.

It does not cover other related system components which may or may not be furnished by YORK. System components should be maintained according to the individual manufacturer's recommendations as their operation will affect the operation of the unit.

### COMPRESSORS

#### Oil Charge

The oil used in these compressors is pale yellow in color. If one of the compressors in a refrigerant system fails to rotate and a replacement is needed, it is strongly recommended to clean the system and refill the oil. Examine the oil color during the process. If the oil darkens or exhibits a change in color, this may be an indication of contaminants in the refrigerant system.

Never use the scroll compressor to pump the refrigerant system down into a vacuum. Doing so will cause internal arcing of the compressor motor which will result in failure of compressor.

### CONDENSER COILS

Dirt should not be allowed to accumulate on the condenser coil surfaces. Cleaning should be as often as necessary to keep coils clean.

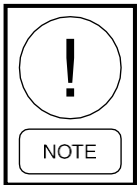

***Exercise care when cleaning the coil so that the coil fins are not damaged.***

### OPERATING PARAMETERS

Regular checks of the system should be performed to ensure that operating temperatures and pressures are within limitations, and that the operating controls are set within proper limits.

Refer to the Operation, Start-Up, and Installation sections of this manual.

### CONDENSER FAN MOTORS

Condenser fan motors are permanently lubricated and require no maintenance.

### OVERALL UNIT INSPECTION

In addition to the checks listed on this page, periodic overall inspections of the unit should be accomplished to ensure proper equipment operation. Items such as loose hardware, component operation, refrigerant leaks, unusual noises, isolators, etc. should be investigated and corrected



immediately.

---

### **EXPANSION TANK**

Unless otherwise stated, at least once every year the expansion tank must be checked to verify that the pre-charge is within the value indicated on the label with a tolerance of  $\pm 20\%$ .

## ModBus Protocol

### DEFINITIONS

NO.	ITEM	DESCRIPTION
1	Data Flow	Communication Baud rate: 9600bps; 8-N-1: 1 start bit, 1 stop bit, check bit-none, 8 data bits; Modbus-RTU Protocol; CRC: Cyclic Redundancy Check; Hexadecimal data.
2	Master - Slave	Modbus as master; 1# microboard as slave.
3	Temperature (Control Panel)	Unit: 0.1 °C; Actual temperature = Register value/10; e.g.: Cool RT Setpoint Register value 0x0078 = 120, then the setpoint is 12.0 °C.
4	Temperature (VSD)	Unit: 0.1 °C; Actual temperature = Register value/10.
5	Pressure	Unit: kPa; Actual pressure = Register value.
6	EEV Opening Degree	Unit: Step; Actual EEV Opening Degree = Register value.
7	Fan Speed	Unit: RPM; Actual Fan Speed = Register value.
8	Compressor Speed	Unit: 0.1 RPS; Actual Compressor Speed = Register value/10.
9	Access Mechanism	BAS parameter setpoint may exceed unit default range and it is required for BAS to read the setpoints from the microboard.
10	BAS Enable	The BAS Modbus addresses of subordinates are set through HMI; Set the corresponding parameters in HMI to enable and disable the BAS Start/Stop and Operating Mode functions.
11	Start/Stop Status	The Start/Stop Command (Register value = 0) is only used to start/stop the unit; Actual Start/Stop Status is accessible by reading Register value = 100.

**SYSTEM SETPOINTS**

NO.	Short Name (BACnet Object Name)	Function Code	Register Address	Note
System Setpoints				
1	Chiller ON/OFF	3, 6, 16	0	0-Invalid, 1-On, 2-Off
2	Mode Setting	3, 6, 16	1	0-Cooling, 1-Heating, 8-Pump Circulation
3	Cool RT Setpoint	3, 6, 16	2	-7~25
4	Heat RT Setpoint	3, 6, 16	3	15~50
5	Cool LT Setpoint	3, 6, 16	4	-10~20
6	Heat LT Setpoint	3, 6, 16	5	20~55
7	Low Sound Mode	3, 6, 16	7	1-Enabled
8	Fault Reset	3, 6, 16	8	1-Reset
9	Cooling Control Select	3, 6, 16	9	0-Fixed RT, 1-Fixed LT, 3-Variable LT
10	Heating Control Select	3, 6, 16	10	0-Fixed RT, 1-Fixed LT, 3-Variable LT
11	Temperature Control Cycle	3, 6, 16	11	20~120, Unit: s
12	Water Temp. Control Diff.	3, 6, 16	12	1~3
13	WT Pulldown Rate	3, 6, 16	14	0~6
14		3, 6, 16	16~99	

## SYSTEM PARAMETERS

NO.	Short Name (BACnet Object Name)	Function Code	Register Address	Note
System Setpoints				
1	Chiller ON/OFF	3	100	0-OFF, 1-ON
2	System Status	3	101	0-Cooling, 1-Heating, 8-Pump
3	Other status	3	102	bit0: 1-Antifreezing bit1: 1-Defrost bit2: 1-Low Sound Mode bit3: Pump Status, 1-On, 0-Off Bit4: Compressor Status, 1-On, 0-Off
4	HMI Communication status	3	103	1-ON, 0-OFF
5	Unit Networks status	3	104	bit0-16: Unit1-16, 1-ON, 0-OFF
6	Unit fault status	3	109	bit0-16: Unit1-16, 1-Fault
7	Chiller EWT	3	110	
8	Chiller LWT	3	111	
9		3	112	
10	Ambient Temp	3	113	
11	Chiller loading	3	114	0-100: 0-100%
12	Available mode	3	115	0-Heat pump, 1-Cooling only
13	Total run hours	3	117	
14	Unit Networks status	3	121	bit0-16: unit17-32, 1-On, 0-Off
15	Unit fault status	3	122	bit0-16: unit17-32, 1-Fault

**UNIT PARAMETERS**

NO.	Short Name (BACnet Object Name)	Function Code	Register Address	Note
Unit				
1	Software Versions A	3	1000-1009	
2	AI1-32	3	1021-1052	
3	Chiller EWT	3	1021	
4	Ambient Temp	3	1022	
5	Ckt1 Coil Temp	3	1023	
6	Ckt2 Coil Temp	3	1024	
7	Unit LWT	3	1025	
8	Chiller LWT	3	1026	
9	Ckt1 Suct Temp	3	1027	
10	Ckt2 Suct Temp	3	1028	
11	Ckt1 Comp1 DLT	3	1029	
12	Ckt1 Comp2 DLT	3	1030	
13	Ckt2 Comp1 DLT	3	1031	
14	Ckt2 Comp2 DLT	3	1032	
15	Ckt1 Suct Pr	3	1040	
16	Ckt2 Suct Pr	3	1041	
17	Ckt1 Disch Pr	3	1042	
18	Ckt2 Disch Pr	3	1043	
19		3	1054	
20	Ckt1 fan motor fault	3		Bit1: 1-Fault
21	Ckt2 fan motor fault	3		Bit2: 1-Fault
22	Ckt1 HPS and Comp1/2 overload	3		Bit3: 1-Fault
23	Ckt1 LPS	3		Bit4: 1-Fault
24	Chiller WFS	3		Bit5: 1-Fault
25	Cooling/Heating mode	3		Bit6: 1-Fault
26	Start/Stop mode	3		Bit7: 1-Fault
27	External Interlock	3		Bit8: 1-Fault
28	Power protector	3		Bit9: 1-Fault
29	Ckt2 HPS and Comp1/2 overload	3		Bit10: 1-Fault
30	Ckt2 LPS	3		Bit11: 1-Fault
31	Unit WFS	3		Bit12: 1-Fault
32		3	1055	
33	Unit water valve	3		bit0: 1-ON, 0-OFF
34		3	1056	
35	Ckt1 fan motor	3		bit0: 1-ON, 0-OFF
36	Ckt1 fan motor speed	3		bit1: 1-ON, 0-OFF
37	Ckt1 Comp1	3		bit2: 1-ON, 0-OFF
38	Ckt1 Comp2	3		bit3: 1-ON, 0-OFF

## UNIT PARAMETERS (CONT'D)

NO.	Short Name (BACnet Object Name)	Function Code	Register Address	Note
39	EVA heater	3		bit4: 1-ON, 1-OFF
40	Ckt1 oil heater	3		bit5: 1-ON, 1-OFF
41	Fault Output	3		bit6: 1-ON, 1-OFF
42	Chiller Pump	3		bit7: 1-ON, 1-OFF
43	Water Heater	3		bit8: 1-ON, 1-OFF
44	VSD fan	3		bit9: 1-ON, 1-OFF
45	Ckt2 Fan Motor	3		bit10: 1-ON, 1-OFF
46	Ckt2 Fan Motor speed	3		bit11: 1-ON, 1-OFF
47	Ckt2 Comp1	3		bit12: 1-ON, 1-OFF
48	Ckt2 Comp2	3		bit13: 1-ON, 1-OFF
49	Ckt1 FWV	3		bit14: 1-ON, 1-OFF
50	Ckt2 FWV	3		bit15: 1-ON, 1-OFF
51	Ckt1 EEV	3	1057	
52	Ckt2 EEV	3	1058	
53	Ckt1 Fan Speed	3	1065	
54	Ckt2 Fan Speed	3	1066	
55	Dial switch Status	3	1073	
56	VSD Info	3	1075-1090	16 addresses for VSD Info
57	Fault Word 1	3	1155	Modular fault codes, 128 bits
58	Fault Word 2	3	1156	
59	Fault Word 3	3	1157	
60	Fault Word 4	3	1158	
61	Fault Word 5	3	1159	
62	Fault Word 6	3	1160	
63	Fault Word 7	3	1161	
64	Fault Word 8	3	1162	
65		3	1164-1199	

## FAULT DEFINITIONS

Address		Fault (BACnet Object Name)	Fault Code	Note	Class
Fault Word 1	Bit0	Chiller EWT sensor fault ★	1A	Bit0: 1-Fault	System
	Bit1	Ambient temp sensor fault ★	2A	Bit1: 1-Fault	System
	Bit2	Ckt1 Coil temp sensor fault	3A	Bit2: 1-Fault	Unit
	Bit3	Ckt2 Coil temp sensor fault	4A	Bit3: 1-Fault	Unit
	Bit4	unit LWT sensor fault	5A	Bit4: 1-Fault	Unit
	Bit5	Chiller LWT sensor fault ★	6A	Bit5: 1-Fault	System
	Bit6	Ckt1 Accu Inlet temp sensor fault	7A	Bit6: 1-Fault	Unit
	Bit7	Ckt2 Accu Inlet temp sensor fault	8A	Bit7: 1-Fault	Unit
	Bit8	Ckt1 Comp1 DLT sensor fault	9A	Bit8: 1-Fault	Unit
	Bit9	Ckt1 Comp2 DLT sensor fault	10A	Bit9: 1-Fault	Unit
	Bit10	Ckt2 Comp1 DLT sensor fault	11A	Bit10: 1-Fault	Unit
	Bit11	Ckt2 Comp2 DLT sensor fault	12A	Bit11: 1-Fault	Unit
	Bit12		13A		
	Bit13		14A		
	Bit14		15A		
	Bit15		16A		
Fault Word 2	Bit0		1b		
	Bit1		2b		
	Bit2		3b		
	Bit3	Ckt1 LPT fault	4b	Bit12: 1-Fault	Unit
	Bit4	Ckt2 LPT fault	5b	Bit13: 1-Fault	Unit
	Bit5	Ckt1 HPT fault	6b	Bit14: 1-Fault	Unit
	Bit6	Ckt2 HPT fault	7b	Bit15: 1-Fault	Unit
	Bit7		8b		
	Bit8		9b		
	Bit9		10b		
	Bit10		11b		
	Bit11		12b		
	Bit12		13b		
	Bit13		14b		
	Bit14		15b		
	Bit15		16b		

**FAULT DEFINITIONS (CONT'D)**

Address		Fault (BACnet Object Name)	Fault Code	Note	Class
Fault Word 3	Bit0	Ckt1 Fan fault	1d	Bit0: 1-Fault	Unit
	Bit1	Ckt2 Fan fault	2d	Bit1: 1-Fault	Unit
	Bit2	Ckt1 HPS fault/ Comp 1 or 2 overload fault	3d	Bit2: 1-Fault	Unit
	Bit3	Ckt1 LPS fault	4d	Bit3: 1-Fault	Unit
	Bit4	Chiller Water flow fault ★	5d	Bit4: 1-Fault	System
	Bit5		6d	Bit5: 1-Fault	
	Bit6		7d	Bit6: 1-Fault	
	Bit7	External interlock fault ★	8d	Bit7: 1-Fault	System
	Bit8	Power fault	9d	Bit8: 1-Fault	Unit
	Bit9	Ckt2 HPS fault/ Comp 1 or 2 overload fault	10d	Bit9: 1-Fault	Unit
	Bit10	Ckt2 LPS fault	11d	Bit10: 1-Fault	Unit
	Bit11	Unit water flow fault	12d	Bit11: 1-Fault	
	Bit12		13d		
	Bit13		14d		
	Bit14		15d		
	Bit15		16d		
Fault Word 4	Bit0		1C		
	Bit1		2C		
	Bit2		3C		
	Bit3		4C		
	Bit4		5C		
	Bit5		6C		
	Bit6		7C		
	Bit7		8C		
	Bit8		9C		
	Bit9		10C		
	Bit10		11C		
	Bit11		12C		
	Bit12		13C		
	Bit13		14C		
	Bit14		15C		
	Bit15		16C		



## FAULT DEFINITIONS (CONT'D)

Address		Fault (BACnet Object Name)	Fault Code	Note	Class
Fault Word 5	Bit0	Comm. Failure (Slave unit with master)	1E	Bit0: 1-Fault	Unit
	Bit1	Chiller Dial Switch setting error	2E	Bit1: 1-Fault	
	Bit2	Time limit protection	3E	Bit2: 1-Fault	System
	Bit3	Low ambient temperature in cooling	4E	Bit3: 1-Fault	System
	Bit4	High ambient temperature in heating	5E	Bit4: 1-Fault	System
	Bit5	Chiller Low LWT in cooling	6E	Bit5: 1-Fault	System
	Bit6	Chiller High LWT in heating	7E	Bit6: 1-Fault	System
	Bit7		8E		
	Bit8		9E		
	Bit9		10E		
	Bit10	Unit Low LWT in cooling	11E	Bit10: 1-Fault	Unit
	Bit11		12E		Unit
	Bit12	Unit high LWT in heating	13E	Bit12: 1-Fault	Unit
	Bit13		14E		Unit
	Bit14	Unit low LWT in heating	15E	Bit14: 1-Fault	Unit
	Bit15		16E		Unit
Fault Word 6	Bit0	Ckt1 comp1 High DPT	1F	Bit0: 1-Fault	Unit
	Bit1	Ckt1 comp2 High DPT	2F	Bit1: 1-Fault	Unit
	Bit2	Ckt2 comp1 High DPT	3F	Bit2: 1-Fault	Unit
	Bit3	Ckt2 comp2 High DPT	4F	Bit3: 1-Fault	Unit
	Bit4		5F		Unit
	Bit5		6F		Unit
	Bit6		7F		Unit
	Bit7		8F		Unit
	Bit8	Ckt1 BPHE anti-freeze protect	9F	Bit8: 1-Fault	Unit
	Bit9	Ckt2 BPHE anti-freeze protect	10F	Bit9: 1-Fault	Unit
	Bit10		11F		
	Bit11		12F		
	Bit12		13F		
	Bit13		14F		
	Bit14	Ckt1 FWV failure	15F	Bit14: 1-Fault	Unit
	Bit15	Ckt2 FWV failure	16F	Bit15: 1-Fault	Unit

**FAULT DEFINITIONS (CONT'D)**

Address		Fault (BACnet Object Name)	Fault Code	Note	Class
Fault Word 7	Bit0	Unit Dial Switch setting error	1p	Bit0: 1-Fault	Unit
	Bit1	Comm failure( unit with driver)	2p	Bit1: 1-Fault	Unit
	Bit2	Comm failure( unit with fan 1)	3p	Bit2: 1-Fault	Unit
	Bit3	Comm failure( unit with fan 2)	4p	Bit3: 1-Fault	Unit
	Bit4		5p		
	Bit5	Driver fault or INV comp fault	6p	Bit5: 1-Fault	Unit
	Bit6		7p		
	Bit7		8p		
	Bit8		9p		
	Bit9		10p		
	Bit10		11p		
	Bit11		12p		
	Bit12		13p		
	Bit13		14p		
	Bit14		15p		
	Bit15		16p		
Fault Word 8	Bit0		1q		
	Bit1		2q		
	Bit2	Ckt1 High pressure alarm	3q	Bit2: 1-Fault	Unit
	Bit3	Ckt2 High pressure alarm	4q	Bit3: 1-Fault	Unit
	Bit4	Ckt1 Low discharge pressure alarm	5q	Bit4: 1-Fault	Unit
	Bit5	Ckt2 Low discharge pressure alarm	6q	Bit5: 1-Fault	Unit
	Bit6	Ckt1 Low pressure alarm	7q	Bit6: 1-Fault	Unit
	Bit7	Ckt2 Low pressure alarm	8q	Bit7: 1-Fault	Unit
	Bit8		9q		
	Bit9		10q		
	Bit10		11q		
	Bit11		12q		
	Bit12		13q		
	Bit13		14q		
	Bit14		15q		
	Bit15		16q		

## PRESSURE TRANSDUCER DIAGRAM

### Low Pressure Transducer

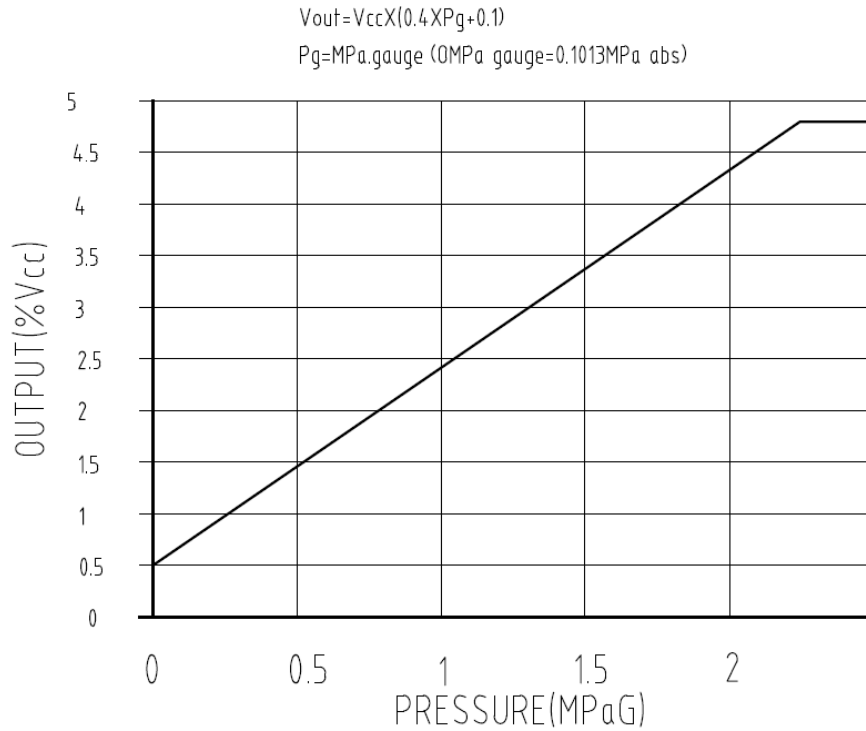

### High Pressure Transducer

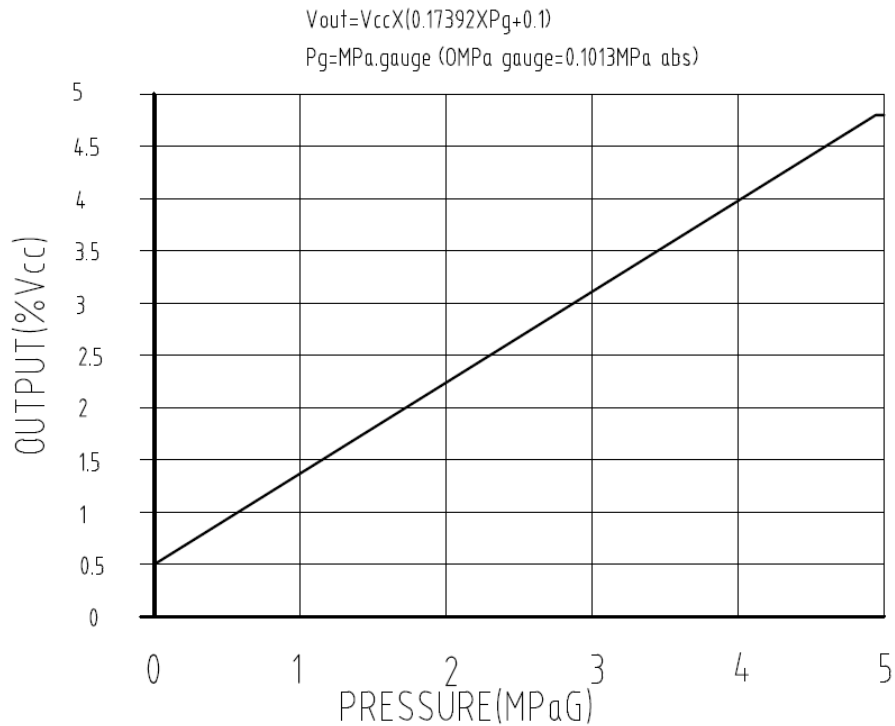

## R410A PRESSURE TEMPERATURE CHART

Gauge Pressure kPa	Temperature °C	Transducer Output
60	-40	-400
70	-39	-390
80	-38	-380
90	-37	-370
100	-36	-360
110	-35	-350
120	-34	-340
140	-33	-330
150	-32	-320
160	-31	-310
170	-30	-300
180	-29	-290
190	-28	-280
210	-27	-270
220	-26	-260
230	-25	-250
250	-24	-240
260	-23	-230
270	-22	-220
290	-21	-210
300	-20	-200
320	-19	-190
340	-18	-180
350	-17	-170
370	-16	-160
380	-15	-150
400	-14	-140
420	-13	-130
440	-12	-120
460	-11	-110
480	-10	-100
500	-9	-90
520	-8	-80
540	-7	-70
560	-6	-60
580	-5	-50
600	-4	-40
630	-3	-30
650	-2	-20
670	-1	-10
700	0	0
720	1	10

Gauge Pressure kPa	Temperature °C	Transducer Output
750	2	20
780	3	30
800	4	40
830	5	50
860	6	60
890	7	70
920	8	80
950	9	90
980	10	100
1010	11	110
1050	12	120
1080	13	130
1120	14	140
1150	15	150
1190	16	160
1220	17	170
1260	18	180
1300	19	190
1340	20	200
1380	21	210
1420	22	220
1460	23	230
1510	24	240
1550	25	250
1600	26	260
1640	27	270
1690	28	280
1740	29	290
1780	30	300
1830	31	310
1890	32	320
1940	33	330
1990	34	340
2040	35	350
2100	36	360
2150	37	370
2210	38	380
2270	39	390
2330	40	400
2390	41	410
2450	42	420
2510	43	430

---

## R410A PRESSURE TEMPERATURE CHART (CONT'D)

Gauge Pressure kPa	Temperature °C	Transducer Output
2570	44	440
2640	45	450
2700	46	460
2770	47	470
2840	48	480
2910	49	490
2980	50	500
3050	51	510
3120	52	520
3200	53	530
3270	54	540
3350	55	550
3430	56	560
3510	57	570
3590	58	580
3670	59	590
3750	60	600
3840	61	610
3920	62	620
4010	63	630
4100	64	640
4190	65	650
4280	66	660
4370	67	670
4470	68	680
4560	69	690
4600	70	700



**YORK Guangzhou Air Conditioning & Refrigeration Co., Ltd.**

Phone: +86 763 4681111



© 2018 Johnson Controls, Inc.

[www.johnsoncontrols.com](http://www.johnsoncontrols.com)

FORM NO.: 6U6H-B01C-NB-EN  
SUPERSEDES: NOTHING

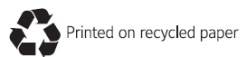

\* Johnson Controls is committed to the continuous product improvement.  
Please note the product design may change without notification.

\*\*This manual is for reference only. For the specific product specifications and performance,  
Please refer to the purchase agreement.

SAP NO.: 5605588