



SUSSMAN

ELECTRIC BOILERS

Series SVS Steam Boiler

Installation, Operation and Maintenance Manual & Spare Parts List



Model No. _____
 Boiler Serial No. _____
 National Board No. _____
 Safety Valve Set Pressure _____ PSIG
 Power Circuit Voltage _____
 Control Circuit Voltage _____
 Amps _____ Phase _____ HZ _____

TABLE OF CONTENTS

1. Scope	1
2. Operating Principles	2
3. Specifications	3-4
4. Installation	4-5
5. Wiring	6
6. Pre-Operation Check	7
7. Pressure Controls, Operation & Testing	7
8. Start-Up and Operation	8
9. Maintenance	9-10
10. Gauge Glass Installation, Use & Care	10-11
11. Drawings & Literature	12
12. Spare Parts	12
13. Trouble Shooting Guide	13
14. Warranty	13

For factory inquiries about this boiler please have available the Model no. and Serial no., Voltage, kW and Phase of the supplied equipment. This information is available on the boiler name plate and operation.

IMPORTANT NOTE:

As you follow these instructions, you will notice warning and caution symbols. This blocked information is important for the safe and efficient installation and operation of electric boilers. These are two types of potential hazards that may occur during this installation and operation:

WARNING states a hazard which may cause serious injury or death if precautions are not followed.

CAUTION signals a situation where minor injury or product damage may occur if you do not follow instructions.

IMPORTANT NOTE: This highlights information that is especially relevant to a problem-free installation.



A Division of Sussman-Automatic Corporation
 43-20 34th Street, Long Island City, NY 11101 • (718) 937-4500
 1-800-238-3535 • Fax: (718) 937-4676 • email: seb@sussmancorp.com
www.sussmanboilers.com

PUR100433 1.17

1.0 Scope

This manual details the installation, operation and maintenance instructions, and spare parts list for Sussman Series SVS Steam Boilers.

Refer to section 10.1 for specific drawings and bills of material for related equipment supplied under this order.

Your SVS Steam Boiler is designed and manufactured to meet ASME regulations. When properly operated and maintained, you can expect years of trouble free service.

Carefully follow the instructions outlined in this manual to ensure proper installation and performance of your boiler.

2.0 Operating Principles

2.1 Principles of Operation

2.1.1 Sussman SVS electric steam boilers utilize state of the art technology, control components, valves and accessories. The Series SVS features vertically positioned heating elements which have many advantages over horizontally positioned elements:

- a. Since the elements are removed from the top, the boiler requires less space.
- b. Vertical steam boiler elements are less prone to scale build-up, a major cause of element failure.
- c. Boilers with vertical elements, being more compact, have faster response time than boilers requiring larger vessels.

2.1.2 Electric boiler operation:

- a. A steel vessel is fitted with tubular resistance type heating elements, inlet and outlet connections, a drain/ blow-down valve(s), an air vent, a water control mechanism, a pressure relief valve, and a temperature control. These devices are configured with a series of electrical controls for automatic operation.
- b. When the boiler is switched on, an electronic level sensor activates a valve which opens to allow water to enter the boiler vessel. The water enters directly from the mains, from a pump connected to the mains, or a receiver tank.
- c. As the boiler fills, the level sensor detects the rising water levels, activates the heating elements and then signals the water inlet valve to close.

d. The boiler is equipped with an adjustable pressure control which will switch off the heaters when the set pressure is reached. Steam pressure determines the steam temperature. Examples of this pressure-temperature relationship are shown below:

Pressure (GAUGE)		Approximate Temp.	
PSIG	KPa	°F	°C
0.00	0	212	100
10.3	71	240	116
34.5	238	280	138
74.9	516	320	160
138.3	954	360	182

f. In many boilers, the pressure regulation controller is backed up by a high pressure limit control. More importantly, all boilers must have a pressure relief valve which will open if the pressure approaches a set point, chosen to be well below the withstand pressure of the boiler components.

Of course, there will come a time (usually measured in years) when the boiler shell and piping will wear away or corrode. Periodic inspections of the vessel interior will give advanced notice of an impending problem. The local boiler inspection authority is available for guidance in these instances.

3.0 Specifications

3.2 Standard Boiler Accessories

The following shows the standard boiler accessories for SVS steam boilers.

STANDARD BOILER ACCESSORIES

- | |
|---|
| <p>No. Description</p> <ol style="list-style-type: none"> 1 Insulated ASME designed pressure vessel 2 Vented control cabinet 3 Pressure relief valve 4 Inspection and cleanout holes 5 Pressure gauge c/w isolating stopcock 6 Sight glass assembly c/w protector 7 Back flow check valve 8 Drain blowdown valve(s) 9 Flanged heaters c/w low watt density element 10 Control circuit transformer (fused) 11 Control circuit on/off switch 12 HRC power fusing 13 Magnetic contactors 14 Indicating pilot lights 15 Electronic low water control 16 Electronic feed water control 17 Electronic high water control (not all models, check factory) 18 On/off staging up to 95 amps 18 Modulating pressure control for units over 95 amps 19 Staging controller with detail no.19 20 High pressure controller |
|---|

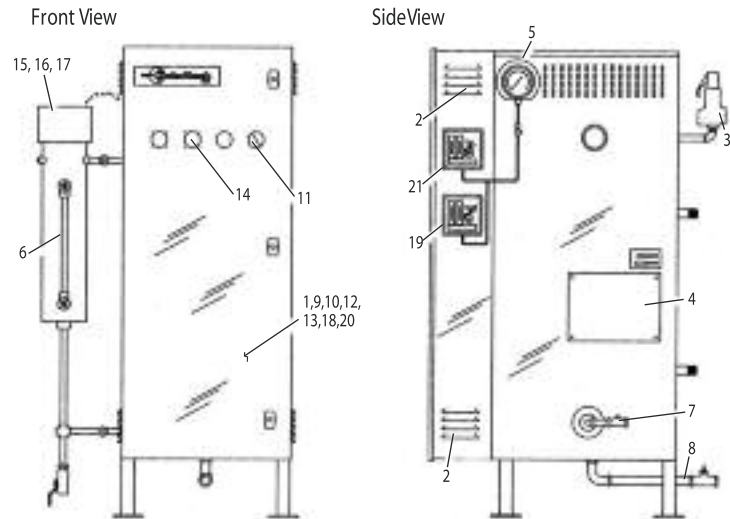

3.3 General Specifications

Listed below is a summary of the approximate minimum clearance requirements, piping sizes and volumes for the various standard boiler types and within this series.

STANDARD DESIGN PRESSURE IS 150 PSIG

TABLE 2 - STEAM BOILER GENERAL SPECIFICATIONS

Up to Max. KW	Vessel Openings (NPT)*						Normal Water Volume GALLONS (Litres)	Normal Steam Chambers GALLONS (Litres)
	WATER INLET	CHEMICA TREATMENT	SURFACE BLOWDOWN	DRAIN VALVE	STEAMOUTLET			
					<15 PSIG (103.5 KPA)	>15 PSIG (103.5 KPA)		
120	3/4	3/4	3/4	3/4	2	2	9.5 (36)	4.1 (15.5)
270	3/4	3/4	3/4	1	3	3	39 (148)	16.9 (64)
648	1	3/4	3/4	1-1/4	4	3	88.2 (334)	37.8 (143)
1512	1-1/4	3/4	3/4	1-1/4	6	4	173 (655)	74.5 (282)

* Outlet flanged above 3" NPT

3.0 Specifications (cont.)

3.4 Other Optional Equipment

Sussman offers the following as options for packaged steam boiler systems. Check to see that optional equipment has been supplied as ordered.

- | | |
|---|--|
| <ul style="list-style-type: none"> <input type="checkbox"/> Feed mechanism - choose from solenoid, pump or receiver feed packag <input type="checkbox"/> Steam outlet globe valve <input type="checkbox"/> Auxiliary low water cutoff <input type="checkbox"/> Manual reset low water cutoff <input type="checkbox"/> Timed auto blowdown system <input type="checkbox"/> Timed surface blowdown system <input type="checkbox"/> Vacuum breaker <input type="checkbox"/> Manual surface blowdown metering valve <input type="checkbox"/> High pressure alarm <input type="checkbox"/> Low pressure alarm <input type="checkbox"/> Audible alarm with silence <input type="checkbox"/> Pilot lights for each stage | <ul style="list-style-type: none"> <input type="checkbox"/> Manual OFF/AUTO staging switch <input type="checkbox"/> Voltmeter with 3 position selector switch <input type="checkbox"/> Ammeter with 3 position selector switch <input type="checkbox"/> kW hour meter <input type="checkbox"/> Main disconnect (unfused) switch <input type="checkbox"/> Main automatic breaker <input type="checkbox"/> Safety door interlock switch <input type="checkbox"/> Proportional controller (std. over 108 kW) <input type="checkbox"/> Electronic sequencer (std. over 108 kW) <input type="checkbox"/> Motor starter with overloads <input type="checkbox"/> Ground fault indicator <input type="checkbox"/> Epoxy sealed elements <input type="checkbox"/> HRC power fusing |
|---|--|

4.0 Installation

4.1 General

The boiler shall be installed by qualified personnel in accordance with the instructions contained in this manual. Furthermore, compliance with applicable National and local building and safety codes is necessary.

4.2 Pre-Installation

4.2.1 Inspect the boiler for possible damage due to shipping and handling. Claims for shipping damage shall be placed with the carrier, and should be reported immediately to them.

If damage has been sustained during shipping that may effect the safe and reliable operation of the boiler, contact the sales office to discuss corrective action.

Have the details shown on the front of this manual available. Do not return the unit unless advised, since field repair may be the preferred course of action.

Returns must include a Return Authorization available from Sussman.

4.2.2 Check the boiler nameplate data to ensure that it corresponds to the supply characteristics (i.e. - voltage, phase, frequency, wattage and pressure relief valve setting).

4.2.3 Consult local codes for specific requirements on the installation of the electric boiler.

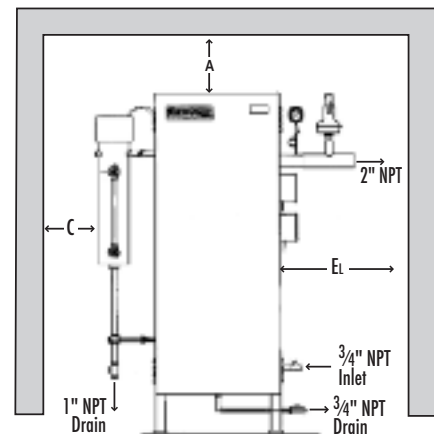
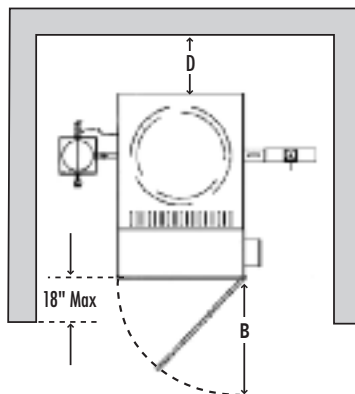

Up to Max kW	Minimum Clearances				
	A	B	C	D	E _L
120	36"	22"	24"	24"	24"
270	36"	32"	24"	24"	24"
648	48"	38"	30"	30"	24"
1512	48"	38"	30"	30"	24"

4.3 Mounting

4.3.1 The boiler must be positioned on an adequate base, preferably concrete, sufficient to support its in-service weight, and then levelled and secured in place.

4.3.2 Adequate clearance on all sides of the boiler is required for access and servicing. Please refer to the above diagram and table for minimum clearance.

4.0 Installation (cont.)

4.4 Plumbing

Refer to drawings in section 10.1 for size and location of water inlet, outlet and other relevant openings.

Ensure that all plumbing connections are made according to local regulations and applicable codes.

4.4.1 Water Supply

All boilers require some type of feed mechanism.

Check to ensure that the correct feed mechanism is used for your system.

a. Solenoid Feed

A solenoid feed can be used if condensate is not required to be returned to the boiler and water pressure is always at least 10 PSIG higher than the maximum boiler operating pressure. The solenoid on the solenoid feed is activated by the level controller.

For connection: Pipe the water supply to the inlet side of the solenoid valve which is pre-installed on the boiler inlet.

b. Pump Feed

A pump feed is to be used when condensate is not required to be returned to the boiler and the water pressure is less than 10 PSIG above the maximum required boiler operating pressure. **NOTE:** The pump motor is normally powered from a separate source.

For connection: Pipe the water supply to the suction side of the pump. Pipe from the pump discharge to the check valve pre-installed on the boiler water inlet.

c. Condensate Receiver Package

For closed loop systems, when condensate is to be returned to the boiler, a condensate return system is required. If supplied by Sussman, the system is packaged as one assembly made up of a feed pump, a receiver tank, stand, make-up water inlet with float control, condensate inlet, vent, drain valve, strainer, sight glass assembly, and shut off valve.

For connection: Pipe the condensate line to the inlet pipe at the top of the receiver tank. Pipe the water supply to the make-up water inlet on the end of the receiver tank.

NOTE: It is assumed that the condensate is released for a steam trap in the heating loop. Good practice is to ensure that the piping from the steam trap slopes down towards

the receiver tank inlet. If the steam line leading into the trap is at a lower level than the trap, a bleed valve just before the trap inlet may be required on some systems.

4.4.2 Backflow Check Valve

The boiler is equipped with a check valve. Note that the check valve is directional. Verify that it is oriented properly. The arrow (on the side of the valve) should point towards the boiler.

4.4.3 Steam Outlet

To facilitate maintenance, a steam outlet valve is recommended for most systems. This may not have been included in your package, and is available from the factory at an additional cost. If the outlet valve is sourced separately, ensure that it is suitable for steam boiler use.

For connection: Pipe the steam outlet from the boiler to the inlet piping of a system designed to withstand a pressure in excess of the boiler relief valve setting.

4.4.4 Blowdown Piping

When the boiler pressure exceeds 15 PSIG (103 KPA) most jurisdictions prohibit the blow-off from the boiler from being directly discharged into the sewer system. However, in all cases, you must check with local authorities to ensure compliance with local regulations prior to the connection of any blowdown piping to any sewer system.

For connection: Pipe the blowdown valve(s) to the inlet of a blowdown tank or a suitable drain (as appropriate).

4.4.5 Pressure Relief Valve

For connection: Pipe the outlet from the pressure relief valve to a suitable drain away from other equipment, walkways and personnel. **NOTE:** Do not reduce the piping size from the pressure relief valve. Do not install any other valves or plugs in this piping.

4.4.6 Utilization of Full Couplings

Utilization of full couplings on the inlet and outlet piping connection may simplify future service requirements. Hot piping loops must be insulated after testing for leaks. Other than personnel safety, uninsulated outlet piping will lower steam quality.

4.5 Electrical

The boiler must be wired by qualified personnel in strict compliance with all codes and regulations. Except for the optional feed water pump and automatic blowdown system, the unit is factory pre-wired. Refer to the wiring diagram included in section 10.1. Field electrical connections are to be made as indicated on this drawing.

4.5.1 Power Supply

With the boiler "ON-OFF" switch in the "OFF" position and the main electrical supply open, connect power feed lines

from a fused disconnect or breaker to the terminals marked L1, L2, and L3 of the boiler disconnect, breaker, or power splitter, whichever is supplied. See section 10.1 for schematic diagram.

4.5.2 Grounding

The boiler must be properly grounded. Attach a suitable ground wire to the ground connection point in the control cabinet sized in accordance with national and local codes.

5.0 Wiring

ALL ELECTRICAL WIRING MUST BE PERFORMED BY A QUALIFIED ELECTRICIAN IN ACCORDANCE WITH NATIONAL AND LOCAL ELECTRICAL CODES.

! CAUTION Assure that the power voltage and phase being supplied to the boiler matches the power voltage and phase of the boiler. Connecting incorrect power supply can damage boiler components or cause improper boiler operation. If the boiler power requirements do not match the power to be supplied to the boiler the boiler must be returned to the factory for conversion. Boilers cannot be field converted.

ALL BOILERS ARE PRE-WIRED AND TESTED PRIOR TO SHIPMENT.

- 5.1. Ground boiler according to National Electric Code requirements to avoid shock.
- 5.2. Power wiring to boiler should be in accordance with National and Local Electrical Code requirements following wiring diagram supplied. Use proper size wire. Wire size is specified adjacent to field wiring terminals. This label states the wire size [AWG or MCM], minimum temperature rating (90 C) and conductor material (copper only). Deviation from these requirements may result in improper or unsafe boiler operation.
- 5.3. A disconnect switch employing circuit breakers or fuses should be installed between the main power source and the boiler. This disconnect switch should be located near the boiler and clearly marked for easy access and identification should the boiler need to be turned off due to an emergency.
- 5.4 Boiler control circuit is 120 Volt*. Unless boiler has an optional step down transformer, a separate 120 Volt power feed wiring is required to be connected to the control circuit terminal block. A 15 Amp circuit is required for all boilers. If a 3/4 HP feed water motor and pump assembly is connected to the boiler, then a 20 Amp circuit is required.
- 5.5. If a separate control circuit is used, it should be connected to the control circuit terminal block.
- 5.6. Remote mounted water feed systems (i.e. condensate return, motor and pump) should be connected to the junction box provided on the outside of the boiler jacket.
- 5.7. With main power off, make sure all wiring terminations are tight to avoid arcing, carbonizing or overheating of contacts.

! CAUTION Boilers are susceptible to lightning damage due to water line connections. An industrial type lightning/surge protector should be installed according to the manufacturer's recommendation at the service entrance. Consult your contractor or electrical dealer.

! WARNING Substitution of components or modification of wiring system voids the warranty and may lead to dangerous operating conditions.

6.0 Pre-Operation Check (All Boilers)

LWCO/PUMP CONTROL OPERATION AND TESTING

- 6.1. All valves for incoming water supply are to be fully opened. Main disconnect switch is to be in the "on" position. Boiler main switch is to be in the "on" position. Since boiler will be empty the pump or solenoid will be energized allowing the boiler to fill with water. Control will automatically fill boiler to proper operating water level and the pump/solenoid will be de-energized. Contactors will then energize, applying voltage to the heating elements.
- 6.2. Pump switch operation – at this point water should be visible approximately half way up the sight glass. Slowly open the drain valve located at the bottom of the boiler. Water level in the sight glass will begin to drop, allowing the low water cut off/pump control to energize the feed water system. Close valve for proper operation.
- 6.3. Low water cutout switch performance – open the drain valve completely. Maintain this condition until water level falls within the gauge glass enough to cause the low water cutout switch to de-energize the heating elements. All of the contactors will be in a de-energized or open state at this time. Close the drain valve, water feed system will automatically refill the boiler and the contactors will re-energize.

Boilers equipped with an auxiliary low water cut-off control with a manual re-set button (required as mandatory equipment in some states): once the correct operating water level has been reached, it will be necessary to depress the reset button in order for the contactors to re-energize.

NOTE: For boilers equipped with an automatic blow-down system:

- **For test 1** - the blowdown time clock must be in the "run" mode before the boiler will automatically fill.
- **For test 2 and 3** - in order for the drain valve to open the blowdown clock must be in the "off" mode. (See blowdown time clock insert) The automatic blowdown indicator light will be on when the valve is open. This light will remain on for the duration of the blowdown cycle (a few seconds). It may be necessary to cycle the time clock from the "run" to "off" mode several times.

7.0 Pressure Controls, Operation and Testing

NOTE: All boilers are provided with one high limit pressure control and at least one operating pressure control.

- 7.1. The high limit pressure control is equipped with a manual reset feature. There is no subtractive differential scale with this type of control
- 7.2. All pressure controls are equipped with an adjusting screw, allowing for setting of desired operational and high limit pressures. To reduce pressure setting, turn adjusting screw in direction that allows indicator to point to a lower pressure setting on the scale. To increase pressure setting turn adjusting screw in direction that allows indicator to point to a higher pressure on the scale

NOTE: It is recommended that the high limit control be set 10 PSIG above the desired normal operating pressure.

- 7.3. Operating pressure controls, except low pressure (15 psig) types have a separate differential scale. Differential indicates pressure below the main operating maximum pressure, the pressure control will re-set. The differential set point is adjusted in the same manner by turning the adjusting screw in the desired direction to increase or decrease the differential pressure value.

7.4. Operating pressure control check: Close steam outlet valve [supplied by customer] and adjust operating pressure control to 20 psig and the differential to 10 psig. Set the high limit pressure control to 30 psig. Switch boiler on to allow steam pressure to build-up. Pressure gauge reading will increase and the operating pressure control will de-energize the contactor(s) when the pressure gauge indicates 20 psig. Open steam outlet valve to bleed off pressure. When the pressure gauge reading decreases below 10 psig (differential) the operating pressure control will re-energize the contactor(s).

7.5. High limit pressure control check: FOR TEST PURPOSES ONLY! Set the high limit pressure control 10 psig lower than the operating pressure control. Close the steam outlet valve and switch the boiler on to allow boiler to build pressure. When the pressure gauge indicates the pressure at which the high limit pressure control is set, the high limit pressure control re-set button will pop-up and the control will de-energize the contactor(s). Open the steam outlet valve to bleed off pressure. The contactor(s) should not re-energize on pressure drop. The contactor(s) should only re-energize when the pressure has dropped and the high limit pressure control reset button is depressed.

8.0 Start-Up and Operation

The following procedures should be performed in sequence to eliminate problems on start-up.

8.1 Start-up

It is presumed that all electrical wiring and plumbing has been checked prior to this start-up procedure.

8.1.1 Make sure that the steam boiler valves are in the following positions:

- Steam Outlet Open
- Drain Valve(s) Closed
- Water Inlet(s) Open
- Blowdown Valve(s) Closed

8.1.2 Adjust the pressure controller to its lowest setting by turning the large screw on the top of the controller.

8.1.3 Make sure that the electrical panel door is closed.

8.1.4 Switch to the "On" position. The green power light and red low level light should then be illuminated indicating that the system has power and a low water level condition exists. If the boiler was previously started, sufficient water may be present and the red low level light will not illuminate. The boiler solenoid valve will activate and the water will enter the boiler until the high water level control closes the valve. Just prior to this, the low level indicator will de-energize the red low level light and energize the heating element. At this point, close the steam valve. The elements will heat the water and begin to generate steam within a few minutes.

8.1.5 Do a first check on the piping system for leaks at connection points and tighten connections as necessary.

8.1.6 Simulate a low water condition by depressing the "push-to-test" button. The boiler contactors should open and the red "low level light" should illuminate. The noise indicates that the elements have been turned off and the light indicates the control is working. You should begin to notice a small pressure requirement. This is not cause for concern. If the boiler has a step controller it may not have had enough time at this low demand situation to activate all the heating stages before satisfying the pressure requirement. This is not cause for concern.

8.1.7 Set the pressure controller (by turning the large screw on top of the controller) to the desired pressure setting. **NOTE:** The pressure control setting should not be set at more than 90% of the relief valve setting. **For example:** If relief valve setting is 100 PSI, set the pressure control at 90 PSI and the differential at 8 PSI. This will allow the boiler to control the pressure to between 82 PSI and 90 PSI.

8.1.8 Set the differential (by turning the small screw on the top of the controller) to the minimum setting.

8.1.9 The pressure will rise on the gauge until the boiler pressure has reached the pressure control setpoint. Do a final check for leaks.

8.1.10 Ensure that the system (external to the boiler) is fully prepared for operation and that personnel are aware that the system is being started up.

8.1.11 Next, slowly open the steam outlet valve, while maintaining pressure, until the valve is fully opened.

8.1.12 Inspect the heating system for leaks and functionality. **NOTE:** Initially, as the system is being heated up, the boiler may not be able to maintain the setpoint pressure. However, if the boiler has been properly sized, after a short period of time the desired operating pressure will be reached and maintained automatically. Undersized steam heating systems will prime i.e. discharge excessive amounts of water through the outlet nozzle. Boilers should not be operated under this condition. You may wish to check factory for assistance. The system should now be operational. It is not normally necessary to pre-boil water to clean the heating elements or the interior of the vessel. They have already been semi-cleaned prior to installation and there is no excessive grease or oil inside the boiler. However, if super-clean conditions make pre-boiling necessary, ensure that the detergents used are not harmful to brass, copper, silver, steel or stainless steel.

8.2 Operation

 **CAUTION** With main disconnect "OFF" tighten all electrical connections before energizing boiler to prevent arcing, carbonizing of contact and/or overheating

8.2.1 If a proper maintenance schedule is followed, all that is required is to turn the boiler on for it to function normally.

Before restarting the boiler, ensure that:

- Steam outlet valve is open
- Water inlet valve(s) is open
- Drain valve(s) are closed
- Pressure control is set to the desired system pressure

8.2.2 Although the boiler can operate safely unattended, it is best to shut the boiler down when it is not required over evenings, weekends or other prolonged periods.

8.2.3 Water treatment may be necessary in some hard water areas since excessive scale build up on internal boiler components will result in heating element failure and costly repairs. Refer to section 9.6 for a discussion on this subject.

9.0 Maintenance



CAUTION HAZARD OF ELECTRIC SHOCK. DISCONNECT ALL ELECTRICAL POWER BEFORE WORKING ON BOILER.

Sussman electric steam boilers, when properly maintained, will provide many years of trouble free service. To establish a good preventative maintenance program, it is recommended that the following maintenance procedures be adhered to.

9.1 Blowdown

Blowdown is an essential part of boiler maintenance. A regularly followed blowdown schedule should result in extended boiler life.

The blowdown schedule should be based on the mineral content of the water and whether the boiler is used in a closed or open system (closed systems utilize a condensate receiver package). For softer water conditions, or for closed systems, weekly blowdown may be sufficient. In open systems, with hard water conditions, daily blowdown is recommended.

Water treatment does not eliminate the need for blowdown.

9.2 Manual Blowdown Procedure

- 9.2.1 De-energize the boiler.
- 9.2.2 Close the water inlet valve.
- 9.2.3 It is best to allow the pressure to drop to 15-20 PSIG before opening the blowdown valve.
- 9.2.4 Open the main drain blowdown valve.
- 9.2.5 Allow the boiler to drain for 10-15 seconds then close the valve.
- 9.2.6 Open the level control column drain valve for 10-15 seconds. (NOTE: Periodically, reverse the sequence of 5.2.5 and 5.2.6. During inspection, if excessive scale inside the vessel is evident, it is best to increase blowdown frequency, not time.)
- 9.2.7 Open the water inlet valve.
- 9.2.8 Restore the boiler "ON-OFF" switch to the "ON" position.

9.3 Automatic Blowdown (optional)

The automatic blowdown package includes/features the following:

- 24 hour, 7 day electronic clock
 - Adjustable cycle time (minimum 1 second)
 - Electric solenoid type automatic drain valve complete with strainer or motorized ball valve (no strainer).
 - Standard bypass loop on drain.
- 9.3.1 The blowdown time and duration is achieved through adjustment of the type 42/2 dual channel timer located in the boiler control enclosure. Refer to the timer manual included with this package for instructions on setting. You must first set the correct time and date followed by the time and duration of each blowdown cycle.

- 9.3.2 As with manual blowdown, a 15-20 second blow-down duration should suffice. In systems using a motorized ball valve add 10 seconds to the set cycle time to allow the valve to open.
- 9.3.3 Open any valves in series with the automatic valve and close any valves that are in parallel.

9.4 Electrical Verification

To avoid risk of electrical shock, disconnect the power supply to the boiler prior to and during electrical servicing.

- 9.4.1 All electrical connections in the power circuit should be inspected and re-tightened periodically.
- 9.4.2 Every 4 months, the following verifications are to be made:
 - a. Check the operation of the low water cutoff control by using the "push-to-test" button. When depressed, all energized heating circuits should immediately go off until the button is released.
 - b. Remove, clean and reinstall all controller electrodes. To ensure that the wires are reconnected to the correct terminals, we recommend that the first electrode be removed, cleaned and reinstalled; then the second and so on.
 - c. If it is suspected that the boiler steam output has dropped, you may wish to verify that all heating elements are functioning.
 - d. Check all fuses for continuity.
 - e. Visually inspect all conductors and contactors for signs of overheating.
 - f. Ensure that all electrical connections are tight.

9.5 Mechanical Verification

9.5.1 Scale Build-Up

Even with regular blowdown, boiler systems involving the heating of large volumes of water may result in a significant amount of solids being deposited within the shell and on the heating elements. Regularly inspect the heating elements through the manhole or handhole. Maintenance frequency will depend on water conditions and operating conditions.

- 9.5.2 Heavy scale buildup on the heating elements results in higher sheath running temperatures resulting in lower heater life and premature failure. This type of failure is not covered under your warranty. Ensure that the following procedure is completed after the first month of operation and as required thereafter.
 - a. If the heating elements are heavily scaled (1/16" or more buildup), all elements require removal and cleaning. Refer to section 9.6.
 - b. Make sure the safety valve is in good working order.
 - c. Clean the upper and lower piping of the level control assembly.

9.0 Maintenance (cont.)

9.6 Cleaning Procedures for Heavy Scale Buildup

9.6.1 Mechanical

- Disconnect power to the boiler by opening the main disconnect.
- Remove the flange heaters from the boiler. **NOTE:** The heater gaskets may not be reusable and replacement gaskets should be on hand. Remember to mark the electrical wire connections and nozzle location for each heater.
- Remove scale by scraping with wire brush, dull metal blade, or by light sandblasting. If sandblasting, take care not to damage the element sheath since normal wall thickness is .030" to .035" (0.8mm).

- Reinstall the heaters, preferably after fitting with new gaskets. Ensure that all plumbing connections are water tight.
- Reconnect the main power and restart the boiler.
- Check once more for leaks when the boiler is up to pressure and correct if necessary.

9.6.2 Chemical

Due to regional variations in water content, Sussman cannot recommend the use of chemicals. Consult a specialist in boiler water treatment for any questions on this subject.

10.0 Gauge Glass Installation, Use and Care

IMPORTANT NOTE: Read all warnings and instructions before performing installation or maintenance. Safety glasses and gloves should be worn at all times when working with or examining water gauge glass and connections. Pressure in generator to be at zero before proceeding. Improper installation or maintenance of gauge glass and connections can cause immediate or delayed breakage resulting in bodily injury and/or property damage.

1. Apply Teflon tape or pipe dope to pipe threads. Install top gauge fitting (fitting without a drain valve) into the uppermost tapping. Wrench tighten the fitting until it is snug and the glass outlet is pointing at five o'clock (about 1/8 turn from its final downward vertical position).
2. Install the bottom gauge fitting (the fitting with a drain valve) until it is snug and the glass outlet is pointing directly upward. Verify top and bottom fittings are threaded into the tapings the same number of turns (distance A = distance B).
3. Remove glass packing nut, friction washer (or packing gland, depending upon the model), and glass packing from the fittings, and place them, in the same order, on to both ends of the gauge glass. Push both packings about an inch up the gauge glass.
4. Gently insert one end of the glass into the top gauge fitting. Keeping the glass inside the top fitting, gently rotate the top gauge fitting clockwise until vertically aligned with the bottom gauge, then insert glass into bottom fitting until glass bottoms out on the shoulder inside the bottom fitting.
5. Carefully raise glass about 1/16" and slide lower glass packing down until the glass packing contacts the lower gauge fitting. **DO NOT** allow the glass to remain in contact with any metal!
6. Carefully slide upper glass packing up as far as possible.
7. Hand tighten both glass packing nuts, then tighten 1/2 turn more by wrench. Tighten only enough to prevent leakage. **DO NOT OVER TIGHTEN!** If any leakage should occur, tighten lightly, a quarter turn at a time, checking for leakage after each turn.

IMPORTANT NOTE: Read all warnings and instructions before performing installation or maintenance.

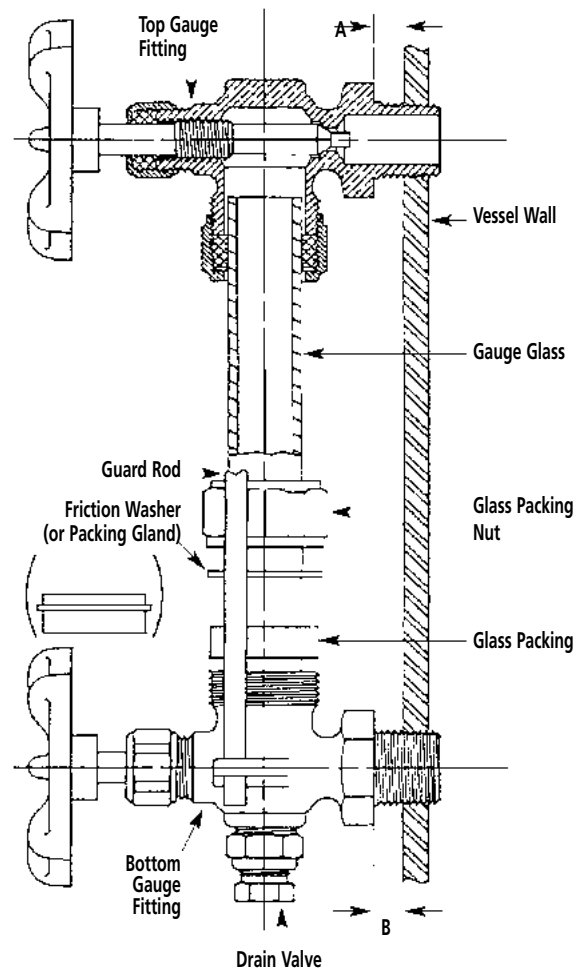

! WARNING Safety glasses and gloves should be worn at all times when working with or examining water gauge glass and connections.

Pressure in generator to be at zero before proceeding.

Improper installation or maintenance of gauge glass and connections can cause immediate or delayed breakage resulting in bodily injury and/or property damage.

10.0 Gauge Glass Installation, Use and Care (cont.)

DO NOTs

- DO NOT use glass if it contains any scratches, chips, or any other visible signs of damage.
- DO NOT reuse any tubular glass or glass packings.
- DO NOT subject gauge glass to bending or torsional stresses.
- DO NOT over tighten glass packing nuts.
- DO NOT allow glass to touch any metal parts.
- DO NOT exceed the recommended pressure of the gauge or gauge glass.
- DO NOT clean the gauge or gauge glass while pressurized or in operation.

DO's

- DO verify proper gauge has been supplied.
- DO examine gauge glass and packings carefully for damage before installation.
- DO install protective guards and utilize automatic ball checks where necessary to help prevent injury in case of glass breakage.
- DO inspect the gauge glass daily, keep maintenance records, and conduct routine replacements.
- DO protect glass from sudden changes in temperatures such as drafts, water spray, etc.

MAINTENANCE

Examine the gauge glass regularly for any signs of clouding, scratching, erosion, or corrosion. The glass should be inspected daily until the need for replacement becomes apparent. This will help establish the routine inspection and routine replacement schedules.

CLEANING

Use commercial non-abrasive glass cleaners to keep glass clean. Use diluted acids such as Hydrochloric (muriatic) acid when regular cleaners do not seem to work. Do not use wire brushes or any other abrasive materials which could scratch the glass.

INSPECTION

Examine the surface of the glass for scratches, corrosion, chips, cracks, surface flaws, or nicks. To do this, shine a very bright concentrated light at an angle of about 45 degrees. A defective glass will glisten as the light strikes imperfections. Glass which appears cloudy or roughened, and will not respond to cleaning, should be replaced.

STORING

Keep gauge glass in original packaging until ready to install.

11.0 Drawings & Literature

11.1 Drawings

The following mechanical and electrical drawings have been included in this manual:

- Boiler Assembly
- Electrical Schematic

11.2 Literature

The following manufacturers' literature, as required, may be included with this manual.

L404A-D,F; L604A,L,M Pressuretrol® Controller	Honeywell
91A,B,D Proportioning Pressure Controller	Honeywell
digi16, digi32 or digi42 Electronic Time Switch	Grasslin
807D Pump Instruction	

12.0 Spare Parts

Refer to section 10.1 drawings to verify the exact part number for the spare parts you require. Have all information on the front of this manual available when ordering any spare parts.

Description	Manufacturer	Catalog No.	
Fuse	Gould	ATM 3/4 A4J25	
		ATM 2 A4J30	
		ATM 6 A4J35	
		ATM 10 A4J40	
		TRM1 A4J45	
		A4J15 A4J50	
		A4J20 A4J60	
Magnetic Contactor	Furnas	42CF35AF 42DF35AF 42CF35AJ	
	Cutler-Hammer	C25DNF340A	
	Relay	FEME	RCPTFU8 2D10 24V RCPTFU113D10 24V RCPTFU82D10 110V RCPTFU113D10 110V
		Electromatic	SV210 SV220 S195
Electrode Holder	Warrick	3B1A	
Electrode	Warrick	1/4" brass (specify length)	
Pilot Light	Leecraft	32RN2111T (RED)	
		32RN2112T (GREEN)	
		32RN2113T (AMBER)	
		32RN2115T (WHITE)	
		32RG1811 (RED)	
		32RG182115T (white)	
		ZA2BV03/ZA2BV6/SP122 (GREEN)	
		ZA2BV01/ZA2BV6/SP122 (WHITE)	
ZA2BV04/ZA2BV6/SP122 (RED)			
ZA2BV05/ZA2BV6/SP122 (AMBER)			

NOTES:

1. To order, specify quantity and catalog number of the part.
2. You must also specify flange heater voltage rating and phase.
3. All parts are shipped F.O.B. factory, freight extra.

Description	Manufacturer	Catalog No.			
Step Controller	Johnson Controls	R26AA-9200 4 step R26AB-9200 6 step R26AC-9200 8 step			
	Consulab	710-4Y-4 step 710-10Y-10 step 710-6Y-6 step 710-20Y-20 step 710-8Y-8 step 710-32Y-32 step			
		Pressure Controller	Honeywell	L91B1035 L91b1050 L404A1586 L404A1594 L404A1602	
			High Limit Pressure Controller	Honeywell	L404C1113 L404C11475 L404A1602
				Flange Heaters (see Note 1)	Sussman
CX110063-60 18kW					
CX110063-65 12kW					
CX110063-75 12kW					
CX110063-80 9kW					
CX110063-100 9kW					
CX110168-10 135kW					
CX110168-17 90kW					
CX110168-18 135kW					
CX110220-07 90kW					
CX110220-10 45kW					
CX110221-03 180kW					
CX110221-04 135kW					
CX110221-05 90kW					
CX110221-06 45kW					
CX110221-09 180kW					
CX110221-10 135kW					
CX110221-11 90kW					
CX110221-12 45kW					

13.0 Troubleshooting Guide

13.1 Failed Heaters

Sussman boiler flange heaters are of the highest quality. When properly maintained, they should provide many years of service.

All heaters undergo a series of rigorous mechanical and electrical inspections. In the event that a heater fails, it is likely that the cause is low water or scale build-up. Multiple coincident failures are almost certainly the result of a low water conditions.

Keep in mind that if new heaters are installed in a boiler where the cause of failure has not been corrected, they too may fail.

13.2 Trouble Shooting Guide

Check Points	Boiler Problems												
	1 "System On" pilot light does not illuminate	2 Low water condition	3 High limit condition	4 Heater fuses fail	5 Main fuses blown	6 Does not fill	7 Leaks water	8 Reset button trips	9 Does not heat	10 Will not reach set temperature	11 Pressure relief valve opens	12 Heaters continually burn out	13 Does not maintain temperature
Pilot Light Burnt Out	x												
Faulty On-Off Switch	x						x	x					
Breaker Reset	x						x	x					
Main Power Switch	x				x			x					
Main Power Fusing	x				x			x					
Flange Heater Failed				x	x			x	x				x
Magnetic Contactor				x	x		x	x	x				
Electrodes & Relay		x		x			x	x			x		
Pressure Controller			x				x	x	x				x
Staging Switch			x				x	x	x				x
Pressure Relief Valve		x				x	x			x			
Pressure Gauge									x				x
Outlet Valve Closed			x							x			
Air in System		x	x			x				x			
High Limit Controller			x				x	x	x	x			
Scale Build-up										x	x		
Heater Fuse				x				x	x				x
Control Transformer	x						x	x					
Control Circuit Wiring	x		x				x	x					
Power Circuit Wiring	x			x	x			x					
Supply Voltage Too High			x	x	x		x						
Supply Voltage Too Low	x							x	x				
System Undersized								x				x	
Leak at Heater Flange		x				x	x						
Piping Leak		x				x	x						
Inlet Valve Closed		x	x			x							

14.0 Warranty

Sussman Automatic Corp. offers a Limited Warranty for this equipment, a copy of which has been included as part of the important documents included with the boiler. Any questions should be referred to Sussman.