

INSTALLATION, OPERATION & SERVICE MANUAL

UNIVERSAL FLOORSTANDING PFWB(C)-EC

PFWBC - With Decorative Cabinet

PFWB - Without Casing

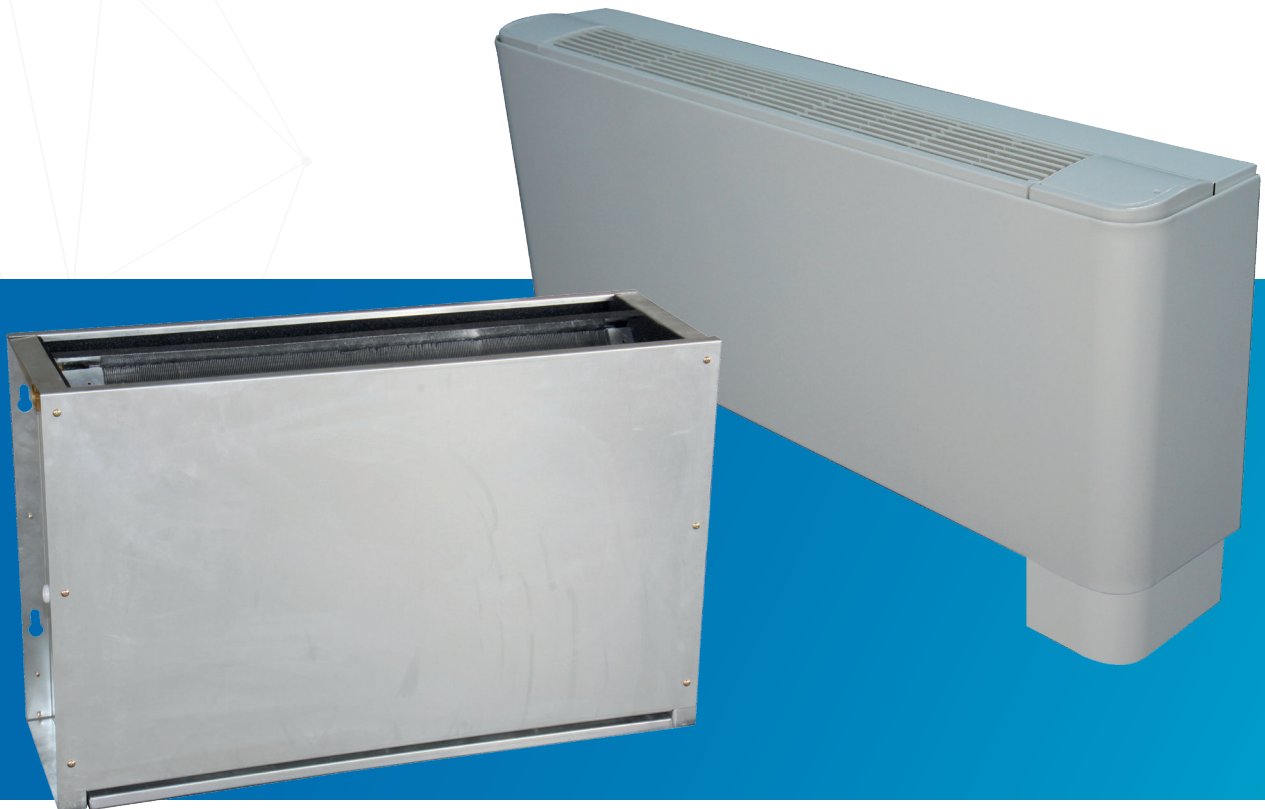

INVESTING IN QUALITY, RELIABILITY & PERFORMANCE.

ISO 9001 QUALITY



Management Service

Every product is manufactured to meet the stringent requirements of the internationally recognized ISO 9001 standard for quality assurance in design, development and production.

World Leading Design and Technology

Equipped with the latest air-conditioning test rooms and manufacturing technology, our factories in China produce over 50,000 fan coil units each year, all conforming to the highest international standards of quality and safety.

CE SAFETY STANDARDS



Product Service

All products conform to the Certificate Europe directives (Machinery Safety, Electromagnetic Compatibility and Low Voltage), as required throughout the European Community, to guarantee correct standards of safety.

The Highest Standards of Manufacturing

In order to guarantee the very highest standards and performance, we manage every stage in the manufacturing of our products. Throughout the production process we maintain strict control, starting with our extensive resources in research and development through to the design and manufacture of almost every individual component, from molded plastics to the assembly of units and controllers.

EUROVENT CERTIFICATION



Quality Controlled from Start to Finish

Our highly trained staff and strict quality control methods enable us to produce products with an exceptional reputation for reliability and efficiency, maintained over many years. As well as full CE certification and ISO 9001, several products ranges have UL / ETL safety approval in the USA and Canada, ROHS compliance for Europe, giving you the confidence of knowing our company is the right choice when selecting fan coil units

WEEE MARK



All products conform to the "WEEE" directive to guarantee correct standards of environmental solutions.

ALWAYS MAKE SURE THIS MANUAL REMAINS WITH THE UNIT. READ THIS MANUAL BEFORE PERFORMING ANY OPERATION ON THE UNIT.

Table of Contents

A. Technical Data	5
<i>A.1. General Description</i>	<i>5</i>
<i>A.2. Unit Appearance.....</i>	<i>6</i>
<i>A.3. General Specifications</i>	<i>7</i>
A.3.1. 2-Pipe Systems	7
A.3.2. 4-Pipe Systems	11
<i>A.4. Coil Data</i>	<i>13</i>
A.4.1. 2-Pipe Systems	13
A.4.2. 4-Pipe Systems	13
<i>A.5. Dimensional Drawings.....</i>	<i>14</i>
<i>A.6. Sound power data</i>	<i>16</i>
B. Installation.....	25
<i>B.1. Safety Precautions</i>	<i>25</i>
<i>B.2. Installation and Location.....</i>	<i>26</i>
<i>B.3. Piping Connections</i>	<i>27</i>
<i>B.4. Coil Direction Interchange.....</i>	<i>28</i>
<i>B.5. Electrical Connection</i>	<i>29</i>
<i>B.6. Valve and External Drain Pan Installation</i>	<i>29</i>
C. Maintenance.....	31
<i>C.1. General Maintenance</i>	<i>31</i>
<i>C.2. Regular Maintenance.....</i>	<i>31</i>
<i>C.3. Filter Installation & Cleaning</i>	<i>31</i>
<i>C.4. Cabinet Removal.....</i>	<i>32</i>
<i>C.5. Fan Motor Assembly Maintenance</i>	<i>32</i>
D. Control Specifications: Intelligent Control (I Type).....	33
<i>D.1. I/O Port Definitions.....</i>	<i>33</i>
<i>D.2. Wiring Diagrams</i>	<i>34</i>
D.2.1. Standard EC-S1 Type Control PCB.....	34
D.2.2. Fan Coil Unit ON/OFF.....	35
D.2.3. Auto Restart	35
<i>D.3. Control Logics for 2-Pipe System</i>	<i>36</i>
D.3.1. With Valve Configuration	36
<i>D.4. Control Logics for 4-Pipe System</i>	<i>39</i>

<i>D.5. Control Logics for 2-pipe with 6-way modulating valve</i>	41
<i>D.6. Sleep Mode</i>	43
<i>D.7. Buzzer</i>	43
<i>The unit will beep once when it receives a signal</i>	43
<i>D.8. Auto Restart</i>	43
<i>D.9. On/Off Switch On LED Display Panel</i>	43
<i>D.10. Drain pump</i>	43
<i>D.11. Float Switch</i>	43
<i>D.12. Electric Heater Safety Switch</i>	44
<i>D.13. Low Temperature Protection of Indoor Coil in Winter</i>	44
<i>D.14. Network Setup</i>	45
<i>D.15. Open Modbus Protocol</i>	47
<i>D.16. LED Display and Error Description</i>	51
E. Control Specifications: Flexible Function (W Type)	52
<i>E.1. Features</i>	52
<i>E.2. I/O Port Definitions</i>	52
<i>E.3. Onboard configuration</i>	52
<i>E.4. Wiring Diagrams</i>	53
<i>E.4.1. Standard EC-W1 Control PCB</i>	53
<i>E.5. Control Logics Specification</i>	54
<i>E.5.1. Unit Power ON/OFF</i>	54
<i>E.5.2. Alarm Protection and Error Display</i>	54
<i>E.5.3. Drain Pump Operation</i>	54
<i>E.5.4. Modulating Signal Input</i>	54
<i>E.5.5. Low Temperature Protection of Indoor Coil in Winter</i>	54
<i>E.6. LED Display and Error Description</i>	55
F. User Interface	56
<i>F.1. Remote Handset</i>	56
<i>F.2. Wired Wall Pad Controller</i>	57
<i>F.2.1. LED display</i>	57
<i>F.2.2. Operation guide</i>	58
<i>F.2.3. Error Code List</i>	62
<i>F.2.4. Dimensions and installation</i>	63
G. Sensor Resistance R-T Conversion Table	64
H. Troubleshooting	66

Model Code Nomenclature

<u>1</u>	2	<u>3</u>	4	5	6	7
<u>PFWB</u>	-3R	<u>-06</u>	<u>-V</u>	<u>-I</u>	<u>-EC</u>	<u>-LS</u>

Notation		Description
1	PFWB	Universal Uncased Unit
2	3R	3R: 2-pipe 3 rows 4R: 2-pipe 4 rows 3+1R: 4-pipe with 3rows cooling and 1 row heating
3	06	Unit Size (See General Specification Section A for cooling and heating capacities.)
4	V	V – 2-pipe P – 4-pipe
5	I	Control type: I – Intelligent Control W – Flexible function Control
6	EC	EC Motor
7	LS	Coil connection: LS : Left side RS : Right side

<u>1</u>	2	<u>3</u>	4	5	6	7	8
<u>PFWBC</u>	-3R	<u>-06</u>	<u>-V</u>	<u>-I</u>	<u>-EC</u>	<u>-VAR</u>	<u>-LS</u>

Notation		Description
1	PFWBC	Universal Cabinet Unit
2	3R	3R: 2-pipe 3 rows 4R: 2-pipe 4 rows 3+1R: 4-pipe with 3rows cooling and 1 row heating
3	06	Unit Size (See General Specification Section A for cooling and heating capacities.)
4	V	V – 2-pipe P – 4-pipe
5	I	Control type: I – Intelligent Control W – Flexible function Control
6	EC	EC Motor
7	VAR	VAR : Vertical air return HAR : Horizontal air return
8	LS	Coil connection: LS : Left side RS : Right side

A. Technical Data

A.1. General Description

Bearing Structure

The bearing structure is made of galvanized sheet-steel with holes for attaching the structure to the wall/ceiling. The "V" type drain pan is used in the unit which ensure the unit can be installed vertically and horizontally. Fire resistant insulation is fitted internally to provide both thermal and acoustic insulation.

Cabinet

The cabinet is made of thick steel-sheet which is resistant to rust, corrosion, chemical agents, solvents, aliphatic compounds and alcohols. The cabinet has thermal acoustic internal insulation and holes to hang the unit from.

Air Delivery Grille

The air delivery grille has fixed fins. Painted with RAL 9010, the metal cabinet has an ABS air discharge grille (only for PFWBC) and is supplied with small side doors for easy access to control panel.

Coil

Constructed with seamless copper tubes and headers. The tubes are mechanically expanded into corrugated aluminum fin material for a permanent primary to secondary surface bond. Coils are tested at 35 bar and recommended for maximum operating at 20 bar. Coils include manual air vent and water purge valve.

Fan Section

The fan section includes 1 or 2 centrifugal fans consisting of double air inlet blades made of forward curving metal fins that are directly attached to the EC motor. The fan section is statically and dynamically balanced. Wide diameter fans create high air flow and high static pressure while fewer revolutions generate a low noise level.

Air Filter

The air filter (G2 efficiency) is easy to remove and is made of a metal frame which holds the filtering materials. It can be cleaned by rinsing with water or by gently vacuuming it. G4 efficiency filter is as optional.

CONTROL SYSTEMS

1. Intelligent control (I type)

Intelligent control board is controlled via Infra-red handset and/or Intelligent wired wall pad, is field programmable and easy to be configured through the wired wall pad or open Modbus protocol with VWV and VAV control logics, provides variable speed indoor fan control, integrates with Intelligent modulating valves to allow Auto Dynamic Balancing and Intelligent Constant Delta T management systems. It controls 2-pipe, 2-pipe with electric heater, 2-pipe with 6-way valve and 4-pipe systems.

2. Flexible control (W type)

This control options features flexible functionality for external thermostat applications, allowing the independent control of drain pumps (if equipped), offering zone control operations, and limited diagnostics. In products where louvers are required, this control allows the stepping motors to open the louver at maximum position or close them when power of the unit is OFF.

A.2. Unit Appearance

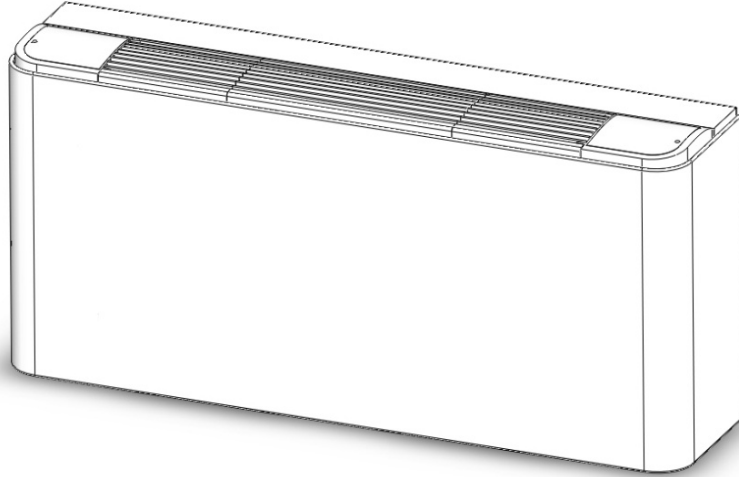

PFWBC-VAR

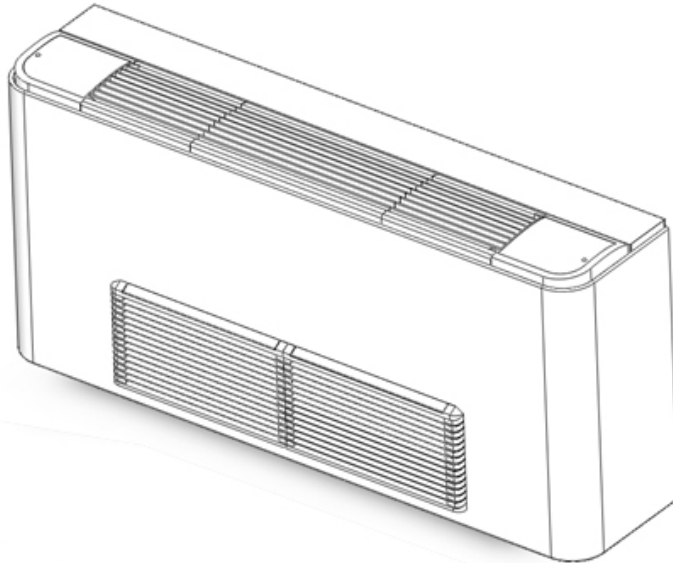

PFWBC-HAR

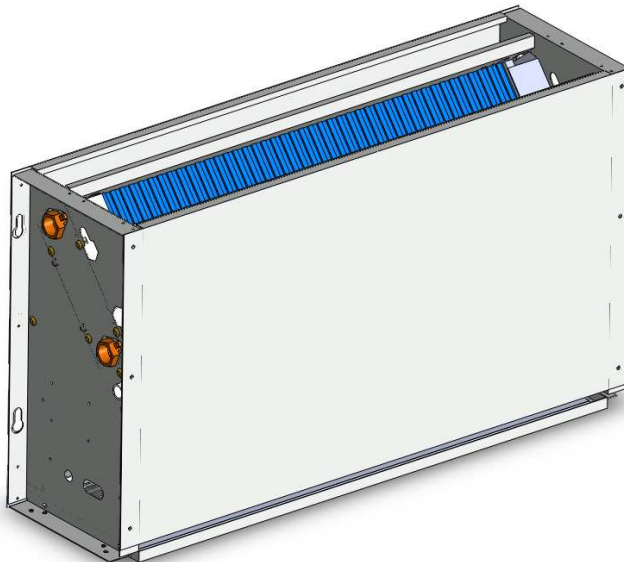

PFWB

A.3. General Specifications

A.3.1. 2-Pipe Systems

Product range: PFWB(C) ECM Universal Uncased/Cabinet Fan Coil Unit

PFWB-3R-V~ECM Universal Uncased 2-pipe Unit with 3-row Coil and EC Motor

PFWBC-3R-V~ECM Universal Cabinet 2-pipe Unit with 3-row Coil and EC Motor



		PFWB(C)-3R-[Size]-V~ECM				06B	09	12B	15B	18	
Unit Configuration	Configuration					2-pipe					
	Number of Fan Blowers					Single		Twin			
	Power Supply		(V/Ph/Hz)			230/1/50 220/1/60					
	Operation Control					~S: Complete function onboard PCB with integrated group control functionality. ~W: Flexible function onboard PCB with zone control functionality.					
Performance Data	Air	Total Air Flow	H	3	m ³ /hr	330	504	677	840	970	
			M	2		280	432	540	697	827	
			L	1		198	342	450	607	677	
	Cooling	Cooling Capacity ^e	H	3	kW	1.84	2.36	3.09	3.9	4.49	
			M	2		1.61	2.1	2.68	3.4	3.96	
			L	1		1.2	1.76	2.33	3.06	3.39	
		Sensible Cooling Capacity ^e	H	3		1.38	1.73	2.37	2.82	3.22	
			M	2		1.21	1.53	2.06	2.43	2.81	
			L	1		0.92	1.27	1.77	2.17	2.39	
		Latent Cooling Capacity	H	3		0.46	0.63	0.72	1.05	1.27	
			M	2		0.4	0.57	0.62	1.1	1.15	
			L	1		0.28	0.49	0.56	0.98	1	
	FCEER ^e	Rating				142	124.07	163.77	125.65	127.55	
		Class				B	B	B	B	B	
	Heating	Heating Capacity ^e	H	3	kW	1.95	2.48	3.13	3.92	4.49	
			M	2		1.69	2.19	2.66	3.43	3.97	
			L	1		1.29	1.82	2.3	3.07	3.41	
		Max. Electric Heater Capacity				1	1.5	2	2	2	
		FCCOP ^e	Rating				151	131.01	163.74	127.59	130.11
	Class				C	C	B	C	C		
	Sound	Sound Pressure Level (Outlet)				41/39/33					
		Sound Power Level (Outlet) ^e				50/48/41					
	Electrical	Power input in cooling mode ^e	H	3	W	15	29	25	44	52	
			M	2		12	20	18	30	36	
L			1	8		12	13	22	23		
Power input in heating mode ^e		H	3	W	16	29	25	44	52		
		M	2		12	20	18	30	36		
L	1	8	12	13	22	23					
Fan Motor Running Current @ H				A	0.15	0.23	0.33	0.38	0.45		
Hydraulic	Cooling Water Flow Rate	3		L/h	280.8	404.9	526.3	668.3	770.1		
		2			247.3	360.3	448.7	583.2	678.7		
		1			188.4	302	386.6	524.6	580.7		
	Cooling Pressure Drop ^e	3		kPa	8.57	18	9.5	19	25.2		
		2			6.74	14.7	6.3	14.9	20.3		
		1			4.2	10.8	5.9	12.3	15.6		
	Heating Water Flow Rate	3		L/h	283	405	536	672	770		
		2			251	361	456	589	681		
		1			191	301	395	526	585		
	Heating Pressure Drop ^e	3		kPa	9.7	17.4	8.32	15.9	21.2		
		2			7.6	14.1	5.5	12.5	17.2		
		1			4.8	10.2	5.11	10.3	13.2		
Water Content				L	0.66	0.74	0.96	1.19	1.26		
Construction and Packing Data	Water Connections	Type		Socket (Threaded Female)							
		In	Out	19.1[3/4]							
	Condensate Drainage Connection										
	Dimensions	L	858				908	1058	1208	1258	
		W	250								
		H	494								
Net Weight				kg	22	24	26	30	32		

^e: Above specifications are based on declared Eurovent test data for the year of publication of this document. To confirm the most updated specifications, please visit www.eurovent-certification.com.

Eurovent testing conditions:

a. Cooling mode (2-pipe/ 4-pipe):

- Return air temperature: 27C DB/ 19C WB.

- Inlet/ Outlet water temperature: 7C/ 12C.

b. Heating mode (2-pipe):

- Return air temperature: 20C.

- Inlet/Outlet water temperature: 45C/40C.



Product range: PFWB(C) ECM Universal Uncased/Cabinet Fan Coil Unit

PFWB-3R-V~-ECM Universal Uncased 2-pipe Unit with 3-row Coil and EC Motor

PFWBC-3R-V~-ECM Universal Cabinet 2-pipe Unit with 3-row Coil and EC Motor

		PFWB(C)-3R-[Size]-V~-ECM			24B	30B	36B	40C	
Unit Configuration	Configuration				2-pipe				
	Number of Fan Blowers				Four				
	Power Supply		(V/Ph/Hz)		230/1/50 220/1/60				
	Operation Control				~S: Complete function onboard PCB with integrated group control functionality. ~W: Flexible function onboard PCB with zone control functionality.				
Performance Data	Air	Total Air Flow	H	3	m ³ /hr	1350	1575	1935	2204
			M	2		1170	1440	1710	2034
			L	1		990	1224	1350	1700
	Cooling	Cooling Capacity ^e	H	3	kW	6.45	6.95	8.47	9.59
			M	2		5.84	6.47	7.67	9.09
			L	1		5.3	5.73	6.39	7.93
		Sensible Cooling Capacity ^e	H	3		5.08	5.07	6.15	6.95
			M	2		4.58	4.68	5.52	6.56
			L	1		4.01	4.12	4.57	5.66
		Latent Cooling Capacity	H	3		1.37	1.88	2.32	2.64
			M	2		1.26	1.79	2.15	2.53
			L	1		1.29	1.61	1.82	2.27
	FCEER ^e	Rating Class			121.57 B	102.7 C	97.7 C	73.99 D	
	Heating	Heating Capacity ^e	H	3	kW	6.5	7.11	8.65	9.72
			M	2		5.9	6.67	7.88	9.22
			L	1		5.40	5.88	6.54	8.00
		Max. Electric Heater Capacity				3	3	3	3
	FCCOP ^e	Rating Class			124.55 C	106.4 C	101.76 C	76.11 D	
	Sound	Sound Pressure Level (Outlet)			dB(A)	51/48/46	55/51/49	57/54/50	60/58/56
		Sound Power Level (Outlet) ^e				59/55/53	64/60/58	66/63/59	69/67/65
	Electrical	Input power in cooling mode ^e	H	3	W	76	100	128	182
			M	2		52	68	92	147
			L	1		40	51	56	92
		Input power in heating mode ^e	H	3	W	76	100	128	182
			M	2		52	68	92	147
			L	1		40	51	56	92
	Fan Motor Running Current @ H			A	0.76	0.87	1.11	1.58	
Hydraulic	Cooling Water Flow Rate	3	L/h	1011	1192	1451	1643		
		2		908.2	1109	1315	1559		
		1		798.6	981.5	1096	1360		
	Cooling Pressure Drop ^e	3	kPa	9.79	12	17.5	23.2		
		2		8.2	9.96	15	21.2		
		1		5.7	8.7	10.7	16.9		
	Heating Water Flow Rate	3	L/h	1046	1218	1473	1663		
		2		942	1144	1350	1580		
		1		831	1008	1121	1372		
	Heating Pressure Drop ^e	3	kPa	15.1	11.3	18.7	19.8		
2		12.6		9.96	26.4	18.2			
1		8.7		7.71	20.1	14.3			
Water Content			L	1.74	1.97	2.19	2.42		
Construction and Packing Data	Water Connections	Type		Socket (Threaded Female)					
		In	mm [in]	19.1[3/4]					
	Out								
	Condensate Drainage Connection								
	Dimensions	L	mm	1758	1758	1908	2058		
W		250							
H		494							
Net Weight			kg	47	47	49	54		

"e": Above specifications are based on declared Eurovent test data for the year of publication of this document. To confirm the most updated specifications, please visit www.eurovent-certification.com.

Eurovent testing conditions:

a. Cooling mode (2-pipe/ 4-pipe)

- Return air temperature: 27C DB/ 19C WB.

- Inlet/ Outlet water temperature: 7C/ 12C.

b. Heating mode (2-pipe):

- Return air temperature: 20C.

- Inlet/ Outlet water temperature: 45/40C.

Product range: PFWB(C) ECM Universal Uncased/Cabinet Fan Coil Unit

PFWB-4R-V~ECM Universal Uncased 2-pipe Unit with 4-row Coil and EC Motor

PFWBC-4R-V~ECM Universal Cabinet 2-pipe Unit with 4-row Coil and EC Motor

Non-standard configuration

		PFWB(C)-4R-[Size]-V~ECM			06	09	12	15	18	
Unit Configuration	Configuration			2-pipe						
	Number of Fan Blowers			Single	Twin					
	Power Supply	(V/Ph/Hz)		230/1/50 220/1/60						
	Operation Control			~S: Complete function onboard PCB with integrated group control functionality. ~W: Flexible function onboard PCB with zone control functionality.						
Performance Data	Air	Total Air Flow	H	3	m ³ /hr	330	504	677	840	970
			M	2		280	432	540	697	827
			L	1		198	342	450	607	677
	Cooling	Cooling Capacity	H	3	kW	1.27	1.8	2.35	2.87	3.39
			M	2		1.12	1.6	2.01	2.51	2.99
			L	1		0.85	1.34	1.73	2.25	2.56
		Sensible Cooling Capacity	H	3		0.87	1.25	1.63	2	2.35
			M	2		0.76	1.1	1.37	1.72	2.05
			L	1		0.57	0.92	1.18	1.54	1.75
	Heating	Heating Capacity*	H	3	kW	1.31	1.85	2.42	2.96	3.49
			M	2		1.15	1.65	2.07	2.58	3.08
			L	1		0.88	1.38	1.78	2.32	2.63
		Max. Electric Heater Capacity				1	1.5	2	2	2
	Sound	Sound Pressure Level (Outlet)			dB(A)	41/39/33	43/40/36	46/43/39	51/46/43	51/48/44
		Sound Power Level (Outlet)				50/48/42	52/49/45	55/52/48	60/55/52	60/57/53
	Electrical	Input power in cooling mode	H	3	W	17	26	38	44	52
			M	2		13	15	23	30	36
			L	1		8	11	13	22	23
		Input power in heating mode	H	3	W	17	26	38	44	52
			M	2		13	15	23	30	36
L			1	8		11	13	22	23	
Fan Motor Running Current @ H			A	0.15	0.23	0.33	0.38	0.45		
Hydraulic	Cooling Water Flow Rate	3		L/h	121	172	224	274	323	
		2			106	153	191	239	285	
		1			81	128	165	215	244	
	Cooling Pressure Drop	3		kPa	17.29	5.12	9.55	5.14	7.12	
		2			13.75	4.15	7.17	4.02	5.67	
		1			8.43	3.02	5.48	3.33	4.28	
	Heating Water Flow Rate	3		L/h	121	172	224	274	323	
		2			106	153	191	239	285	
		1			81	128	165	215	244	
	Heating Pressure Drop	3		kPa	15.56	4.61	8.60	4.63	6.41	
2		12.38	3.74		6.45	3.62	5.10			
1		7.59	2.72		4.94	2.99	3.86			
Water Content			L	0.88	0.99	1.28	1.59	1.68		
Construction and Packing Data	Water Connections	Type		Socket (Threaded Female)						
		In	mm [in]	19.1[3/4]						
	Condensate Drainage Connection									
	Dimensions	L	mm	858	908	1058	1208	1258		
		W		250						
		H		494						
Net Weight			kg	22	24	26	30	32		

a. Cooling mode (2-pipe):

- Return air temperature: 24C DB/ 18C WB.
- Inlet/ Outlet water temperature: 5.5C/ 14.5C.

b. Heating mode (2-pipe):

- Return air temperature: 24C.
- Inlet water temperature: 50C.

Product range: PFWB(C) ECM Universal Uncased/Cabinet Fan Coil Unit

PFWB-4R-V~-ECM Universal Uncased Unit 4-row coil 2-pipe with EC Motor

PFWBC-4R-V~-ECM Universal Cabinet Unit 4-row coil 2-pipe with EC Motor

Non-standard configuration

		PFWB(C)-4R-[Size]-V~-ECM			24	30	36	40	
Unit Configuration	Configuration				2-pipe				
	Number of Fan Blowers				Four				
	Power Supply		(V/Ph/Hz)		230/1/50 220/1/60				
	Operation Control				~S: Complete function onboard PCB with integrated group control functionality. ~W: Flexible function onboard PCB with zone control functionality.				
Performance Data	Air	Total Air Flow	H	3	m ³ /hr	1350	1575	1935	2204
			M	2		1170	1440	1710	2034
			L	1		990	1224	1350	1700
	Cooling	Cooling Capacity	H	3	kW	4.8	5.86	6.93	8.05
			M	2		4.31	5.45	6.28	7.64
			L	1		3.79	4.83	5.23	6.66
		Sensible Cooling Capacity	H	3		3.34	4.07	4.8	5.58
			M	2		2.96	3.76	4.31	5.28
			L	1		2.59	3.3	3.56	4.55
	Heating	Heating Capacity	H	3	kW	4.94	6.03	7.13	8.29
			M	2		4.44	5.61	6.46	7.86
			L	1		3.9	4.97	5.38	6.86
		Max. Electric Heater Capacity					3	3	3
	Sound	Sound Pressure Level (Outlet)			dB(A)	51/48/46	55/51/49	57/54/50	60/58/56
		Sound Power Level (Outlet)				60/57/55	64/60/58	66/63/59	69/67/65
	Electrical	Input power in cooling mode	H	3	W	87	100	128	182
			M	2		60	71	92	147
			L	1		40	51	56	92
		Input power in heating mode	H	3	W	87	100	128	182
			M	2		60	71	92	147
			L	1		40	51	56	92
	Fan Motor Running Current @ H				A	0.76	0.87	1.11	1.58
	Hydraulic	Cooling Water Flow Rate	3		L/h	457	558	660	767
			2			411	519	598	727
			1			361	460	498	635
		Cooling Pressure Drop	3		kPa	7.51	11.67	17.01	23.87
			2			6.19	10.25	14.25	21.71
1			4.91	8.23		10.25	16.98		
Heating Water Flow Rate		3		L/h	457	558	660	767	
		2			411	519	598	727	
		1			361	460	498	635	
Heating Pressure Drop		3		kPa	6.76	10.51	15.31	21.48	
		2			5.57	9.23	12.82	19.54	
		1			4.42	7.41	9.23	15.28	
Water Content				L	2.32	2.63	2.92	3.23	
Construction and Packing Data	Water Connections	Type		Socket (Threaded Female)					
		In	mm [in]	19.1[3/4]					
	Out								
	Condensate Drainage Connection								
	Dimensions	L	mm	1758	1758	1908	2058		
		W		250					
H		494							
Net Weight				kg	47	47	49	54	

a. Cooling mode (2-pipe):

- Return air temperature: 24C DB/ 18C WB.
- Inlet/ Outlet water temperature: 5.5C/ 14.5C.

b. Heating mode (2-pipe):

- Return air temperature: 24C.
- Inlet water temperature: 50C.

A.3.2. 4-Pipe Systems

Product range: PFWB(C) ECM Universal Uncased/Cabinet Fan Coil Unit

PFWB-3R+1-P~-ECM Universal Uncased Unit with EC Motor - Auxiliary Heating Coil (1 row)

PFWBC-3R+1-P~-ECM Universal Cabinet Unit with EC Motor - Auxiliary Heating Coil (1 row)

Non-standard configuration

		PFWB(C)(3+1R)-[Size]-V~-ECM			06B	9	12B	15B	18	24B	30B	36B	40C	
Unit Configuration	Configuration				2-pipe									
	Number of Fan Blowers				Single	Twin				Four				
	Power Supply		(V/Ph/Hz)		230/1/50									
					220/1/60									
Performance Data	Air	Total Air Flow	H	3	m ³ /hr	330	504	677	840	970	1350	1575	1935	2204
			M	2		280	432	540	697	827	1170	1440	1710	2034
			L	1		198	342	450	607	677	990	1224	1350	1700
	Cooling	Cooling Capacity ^e	H	3	kW	1.84	2.36	3.09	3.90	4.49	6.45	6.95	8.47	9.59
			M	2		1.61	2.10	2.68	3.40	3.96	5.84	6.47	7.67	9.09
			L	1		1.20	1.76	2.33	3.06	3.39	5.30	5.73	6.39	7.93
		Sensible Cooling Capacity ^e	H	3		1.38	1.73	2.37	2.82	3.22	5.08	5.07	6.15	6.95
			M	2		1.21	1.53	2.06	2.43	2.81	4.58	4.68	5.52	6.56
			L	1		0.92	1.27	1.77	2.17	2.39	4.01	4.12	4.57	5.66
		Latent Cooling Capacity	H	3		0.46	0.63	0.72	1.05	1.27	1.37	1.88	2.32	2.64
			M	2		0.40	0.57	0.62	1.10	1.15	1.26	1.79	2.15	2.53
			L	1		0.28	0.49	0.56	0.98	1.00	1.29	1.61	1.82	2.27
		FCEER ^e	Rating			142.00	124.07	163.77	126.75	127.55	121.57	102.70	97.70	73.99
	Class			B	B	B	B	B	B	C	C	D		
	Heating	Heating Capacity ^e	H	3	kW	1.62	2.29	3.06	3.81	4.27	5.9	6.89	8.22	9.29
			M	2		1.43	2.02	2.6	3.32	3.83	5.35	6.41	7.52	8.77
			L	1		1.09	1.71	2.25	2.96	3.3	4.67	5.67	6.31	7.72
		FCCOP ^e	Rating			124.4	143	143.1	123.7	126.1	104.1	101.6	98.4	73.5
	Class			C	C	C	C	C	C	C	D	D		
	Sound	Sound Pressure Level (Outlet)			dB(A)	41/39/33	43/40/36	46/43/39	51/46/43	51/48/44	51/48/46	55/51/49	57/54/50	60/58/56
		Sound Power Level (Outlet) ^e				50/48/41	52/49/45	52/49/46	58/53/51	60/57/53	59/55/53	64/60/58	66/63/59	69/67/65
	Electrical	Power input in cooling mode ^e	H	3	W	15	29	25	44	52	76	100	128	182
			M	2		12	20	18	30	36	52	68	92	147
			L	1		8	12	13	22	23	40	51	56	92
Power input in heating mode ^e		H	3	W	16	29	25	50	52	76	100	128	182	
		M	2		12	20	18	33	36	52	68	92	147	
		L	1		8	12	13	24	23	40	51	56	92	
Fan Motor Running Current @ H				A	0.15	0.23	0.33	0.38	0.45	0.76	0.87	1.11	1.58	
Hydraulic	Cooling Water Flow Rate		3	L/h	280.80	404.90	526.30	668.30	770.10	1011.00	1192.00	1451.00	1643.00	
			2		247.30	360.30	448.70	583.20	678.70	908.20	1109.00	1315.00	1559.00	
			1		188.40	302.00	386.60	524.60	580.70	798.60	981.50	1096.00	1360.00	
	Cooling Pressure Drop ^e		3	kPa	8.91	17.76	10.84	19.01	25.02	7.74	11.24	17.26	23.30	

PG2021 PFWBC-VP-ECM-005

Construction and Packing Data		2	7.08	14.40	8.14	14.87	19.93	6.38	9.87	14.46	21.18	
		1	4.34	10.48	6.23	12.29	15.05	5.06	7.92	10.41	16.57	
	Heating Water Flow Rate	L/h	3	138	196	262	326	366	506	590	705	796
			2	122	173	223	285	329	458	549	645	752
			1	93	147	193	254	282	401	486	541	662
	Heating Pressure Drop ^e	kPa	3	4.09	8.14	16.14	27.75	35.74	11.7	17	25.63	34.51
			2	3.28	6.49	12.06	21.71	29.4	9.79	14.93	21.84	31.11
			1	2.01	4.82	9.3	17.69	22.38	7.69	11.99	15.91	24.74
	Water Content		L	0.88	0.99	1.28	1.59	1.68	2.32	2.63	2.92	3.23
	Water Connections	Type		Socket (Threaded Female)								
		Cooling	In	19.1 [3/4]								
			Out	12.7 [1/2]								
Heating		In	19.1 [3/4]									
	Out	19.1 [3/4]										
Condensate Drainage Connection		19.1 [3/4]										
Dimensions	L	mm	858	908	1058	1208	1258	1758	1758	1908	2058	
	W		250									
	H		494									
Net Weight		kg	23	26	28	32	34	45	49	52	57	

^e: Above specifications are based on declared Eurovent test data for the year of publication of this document. To confirm the most updated specifications, please visit www.eurovent-certification.com.

Eurovent testing conditions:

Cooling mode (2-pipe/ 4-pipe):

- Return air temperature: 27C DB/ 19C WB.

- Inlet/ Outlet water temperature: 7C/ 12C.

Heating mode (4-pipe):

- Return air temperature: 20C.

- Inlet/ Outlet water temperature: 65C/ 55C.

A.4. Coil Data

A.4.1. 2-Pipe Systems

COIL DATA (2 PIPE SYSTEM 3 ROW)

Model	Fin height (mm)	Fin Length (mm)	Fins per Inch	No. of Rows	Fin width (mm)	No. of Circuits	Tube Ø (mm)
PFWB(C)-06	200	441	12.7	3	66	2	9.52
PFWB(C)-09		491				2	
PFWB(C)-12		641				3	
PFWB(C)-15		791				3	
PFWB(C)-18		841				3	
PFWB(C)-24		1161				6	
PFWB(C)-30		1311				6	
PFWB(C)-36		1462				6	
PFWB(C)-40		1611				6	

COIL DATA (2 PIPE SYSTEM 4 ROW)

Model	Fin height (mm)	Fin Length (mm)	Fins per Inch	No. of Rows	Fin width (mm)	No. of Circuits	Tube Ø (mm)
PFWB(C)-06	200	441	12.7	4	88	3	9.52
PFWB(C)-09		491				3	
PFWB(C)-12		641				4	
PFWB(C)-15		791				4	
PFWB(C)-18		841				4	
PFWB(C)-24		1161				6	
PFWB(C)-30		1311				6	
PFWB(C)-36		1462				6	
PFWB(C)-40		1611				6	

A.4.2. 4-Pipe Systems

HEATING COIL DATA (4 PIPE SYSTEM WITH 1 ROW REMOVABLE HEATING COIL)

Model	Fin height (mm)	Fin Length (mm)	Fins per Inch	No. of Rows	Fin width (mm)	No. of Circuits	Tube Ø (mm)
PFWB(C)-06	200	441	12.7	1	22	1	9.52
PFWB(C)-09		491					
PFWB(C)-12		641					
PFWB(C)-15		791					
PFWB(C)-18		841				2	
PFWB(C)-24		1161					
PFWB(C)-30		1311					
PFWB(C)-36		1462					
PFWB(C)-40		1611					

A.5. Dimensional Drawings
Dimensional Drawings: PFWB series

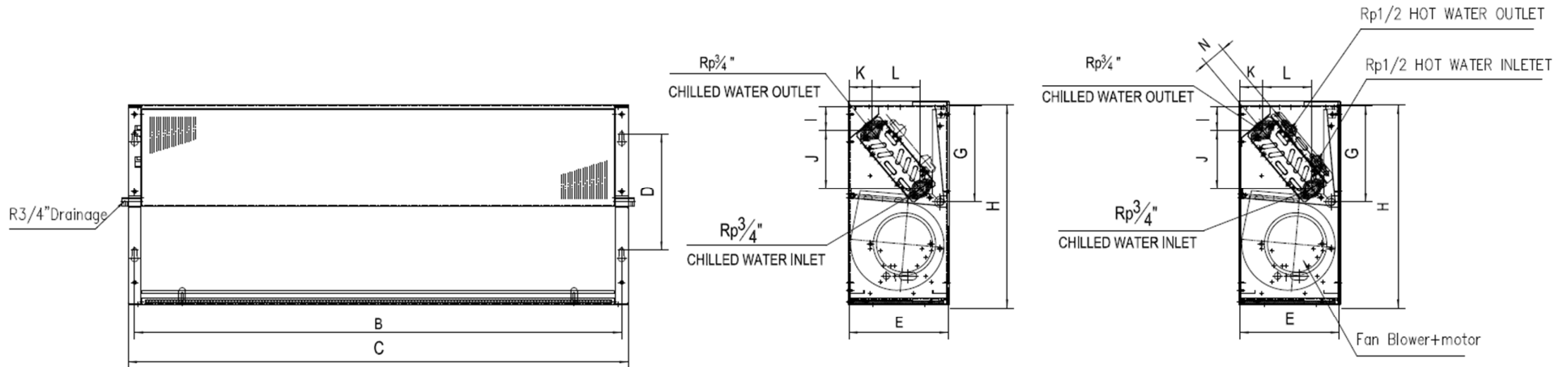

Model	B	C	D	E	G	H	I	J	K	L	N
PFWB-06	578	608	270	230	223	460	57	134	52	112.5	50
PFWB-09	628	658	270	230	223	460	57	134	52	112.5	50
PFWB-12	778	808	270	230	223	460	57	134	52	112.5	50
PFWB-15	928	958	270	230	223	460	57	134	52	112.5	50
PFWB-18	978	1008	270	230	223	460	57	134	52	112.5	50
PFWB-24	1478	1508	270	230	223	460	57	134	52	112.5	50
PFWB-30	1478	1508	270	230	223	460	57	134	52	112.5	50
PFWB-36	1628	1658	270	230	223	460	57	134	52	112.5	50
PFWB-40	1778	1808	270	230	223	460	57	134	52	112.5	50

(All dimensions shown in mm)

Dimensional Drawings: PFWBC series

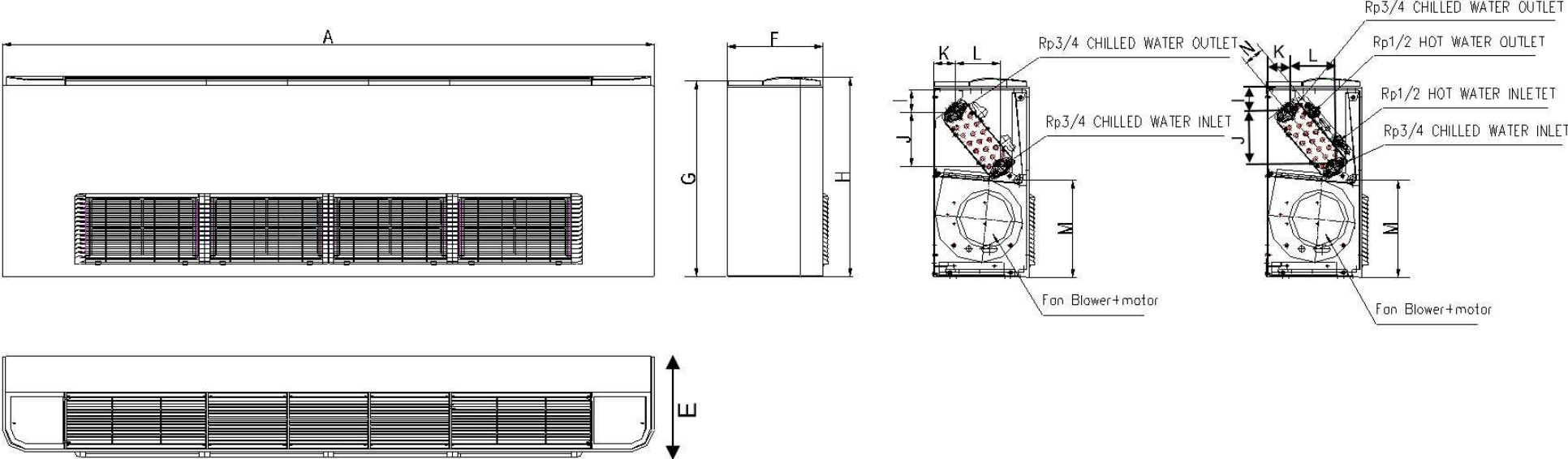

Model	A	B	C	D	E	F	G	H	I	J	K	L	M	N
PFWBC-06	858	578	608	270	250	235	484	494	57	134	52	112.5	242	50
PFWBC-09	908	628	658	270	250	235	484	494	57	134	52	112.5	242	50
PFWBC-12	1058	778	808	270	250	235	484	494	57	134	52	112.5	242	50
PFWBC-15	1208	928	958	270	250	235	484	494	57	134	52	112.5	242	50
PFWBC-18	1258	978	1008	270	250	235	484	494	57	134	52	112.5	242	50
PFWBC-24	1758	1478	1508	270	250	235	484	494	57	134	52	112.5	242	50
PFWBC-30	1758	1478	1508	270	250	235	484	494	57	134	52	112.5	242	50
PFWBC-36	1908	1628	1658	270	250	235	484	494	57	134	52	112.5	242	50
PFWBC-40	2058	1778	1808	270	250	235	484	494	57	134	52	112.5	242	50

(All dimensions shown in mm)

A.6. Sound power data

Model	PFWBC-06											
Speed	H (800)	M(690)	L(530)	700RPM	800RPM	900RPM	1000RPM	1100RPM	1200RPM	1300RPM	1400RPM	
Sound Power dB(A)	50.6	45.9	38.5	46.5	50.5	53.5	56.4	59.2	61.2	63.3	65.1	
Sound Power in 1/3 Octave-bands under ESP:0Pa	20.0Hz	12.2	17.6	18.6	20.6	17.4	18.3	14.0	21.6	15.0	19.7	13.7
	25.0Hz	12.8	17.2	16.7	25.0	22.4	19.4	19.6	21.7	16.7	15.2	17.7
	31.5Hz	18.5	12.4	13.0	19.3	16.8	10.8	17.8	16.4	14.3	11.8	12.7
	40.0Hz	15.2	8.0	12.5	11.2	13.5	11.3	11.7	13.6	14.8	10.3	17.2
	50.0Hz	18.3	14.1	16.1	13.0	16.4	16.0	13.3	17.9	17.4	15.0	17.8
	63.0Hz	15.7	13.6	16.5	13.5	13.1	15.9	21.1	18.7	16.4	16.6	18.9
	80.0Hz	10.0	9.4	8.4	8.4	16.1	13.7	16.4	16.9	18.9	20.4	23.5
	100.0Hz	15.5	12.3	10.2	12.1	23.9	19.3	19.6	23.8	25.9	28.1	30.3
	125.0Hz	20.6	16.0	11.8	18.5	26.5	25.3	26.7	27.3	30.0	33.5	34.9
	160.0Hz	27.1	23.5	16.9	23.4	28.6	30.4	34.3	34.0	37.0	38.5	39.3
	200.0Hz	31.1	29.5	22.6	27.6	33.5	35.2	38.3	38.2	42.0	43.9	45.8
	250.0Hz	36.9	34.2	26.5	33.2	35.8	37.6	42.3	43.0	47.0	47.0	50.2
	315.0Hz	38.3	35.1	30.8	35.5	38.5	41.1	43.9	47.2	49.5	51.2	52.0
	400.0Hz	38.3	34.7	28.0	35.0	38.3	41.7	44.1	46.9	49.2	51.0	52.0
	500.0Hz	43.6	39.9	30.4	38.5	42.2	46.3	47.2	47.7	50.9	52.0	52.5
	630.0Hz	42.9	36.1	28.8	38.3	41.2	44.7	47.0	48.6	51.0	53.1	54.2
	800.0Hz	39.0	35.1	27.4	36.2	40.3	42.4	45.6	48.6	50.6	52.7	54.2
	1000.0Hz	40.3	37.2	27.2	35.5	40.8	44.7	47.5	50.3	53.7	55.1	56.5
	1250.0Hz	38.5	34.2	24.3	36.0	38.1	41.1	44.9	47.4	50.6	52.1	54.1
	1600.0Hz	40.5	34.9	23.4	36.1	41.4	42.6	44.7	47.9	49.5	52.0	54.3
2000.0Hz	37.7	30.4	21.5	30.7	38.1	43.8	45.4	47.9	48.9	51.0	52.9	
2500.0Hz	34.2	28.3	21.3	29.4	34.0	39.1	44.1	49.4	51.1	52.3	53.1	
3150.0Hz	31.7	25.5	21.1	26.1	31.1	35.4	39.7	43.3	46.9	50.5	52.7	
4000.0Hz	30.6	25.1	20.9	25.1	29.9	34.3	38.2	41.5	45.2	47.7	50.0	
5000.0Hz	29.0	23.8	20.7	24.2	28.6	32.6	36.5	40.3	43.6	45.6	48.1	
6300.0Hz	25.4	21.5	20.8	21.4	25.0	28.7	33.1	37.1	40.3	42.9	45.0	
8000.0Hz	22.0	19.7	19.3	19.8	22.0	24.9	28.9	32.3	36.6	39.0	41.6	
10000.0Hz	18.5	17.5	17.7	17.7	18.6	20.5	23.5	27.7	31.0	33.8	36.1	
12500.0Hz	15.0	14.7	14.8	14.6	15.1	16.1	19.0	21.9	25.4	28.5	30.6	
16000.0Hz	11.8	11.8	11.8	11.5	11.5	12.3	16.6	15.4	17.7	20.2	22.6	

Model	PFWBC-09												
Speed	H(900)	M(750)	L(650)	600RPM	700RPM	800RPM	900RPM	1000RPM	1100RPM	1200RPM	1300RPM	1400RPM	
Sound Power dB(A)	51.9	47.0	42.9	40.7	45.0	48.9	51.9	55.3	57.3	60.2	62.1	64.1	
Sound Power in 1/3 Octave-bands under Esp:0Pa	20.0Hz	16.2	20.3	17.8	16.1	19.5	21.1	16.2	13.1	17.3	15.7	19.5	20.3
	25.0Hz	14.4	20.1	18.7	18.6	18.7	21.5	14.4	15.0	17.0	13.1	18.3	20.2
	31.5Hz	17.7	18.6	18.0	16.6	19.4	17.9	17.7	17.7	21.5	16.1	16.4	13.5
	40.0Hz	9.2	11.3	10.7	11.1	10.4	12.2	9.2	12.2	16.3	12.7	22.4	11.3
	50.0Hz	14.4	15.3	14.4	14.9	13.9	16.7	14.4	18.1	19.2	14.2	16.9	17.1
	63.0Hz	16.9	17.7	18.0	17.2	18.8	16.7	16.9	20.1	19.3	17.4	20.5	21.9
	80.0Hz	14.9	11.4	8.3	6.8	9.7	13.1	14.9	17.2	18.5	18.5	19.4	23.7
	100.0Hz	18.7	15.5	11.4	9.5	13.2	17.7	18.7	20.8	20.7	25.8	27.3	28.8
	125.0Hz	25.9	20.7	16.0	15.7	16.4	25.1	25.9	27.4	29.6	33.5	33.5	37.2
	160.0Hz	30.5	25.6	21.7	20.3	23.2	27.9	30.5	33.9	34.4	37.8	38.3	40.6
	200.0Hz	34.2	31.1	27.2	25.6	28.9	33.2	34.2	36.7	39.8	41.9	45.2	48.3
	250.0Hz	36.6	34.3	31.2	29.8	32.5	36.0	36.6	41.7	44.0	46.8	48.5	49.9
	315.0Hz	41.7	37.1	33.0	30.9	35.0	39.3	41.7	44.2	47.1	48.5	51.8	53.4
	400.0Hz	39.9	35.8	32.0	30.0	34.1	37.6	39.9	43.0	44.6	47.5	50.1	50.5
	500.0Hz	40.8	36.5	32.9	30.6	35.1	37.9	40.8	44.6	45.0	48.4	49.5	51.8
	630.0Hz	43.2	38.4	33.7	31.7	35.8	41.1	43.2	46.4	47.8	50.5	52.2	54.3
	800.0Hz	42.3	36.6	32.3	30.4	34.2	39.1	42.3	45.9	48.3	49.8	52.2	53.1
	1000.0Hz	44.2	38.3	33.6	31.4	35.9	40.7	44.2	46.7	48.6	51.8	54.2	55.7
	1250.0Hz	42.5	36.5	31.6	28.7	34.6	38.4	42.5	46.4	47.8	50.7	51.5	53.9
	1600.0Hz	41.0	34.2	28.6	25.6	31.5	36.9	41.0	43.5	46.0	48.6	50.6	52.9
2000.0Hz	38.3	31.6	26.4	24.1	28.7	34.4	38.3	42.1	44.8	48.0	49.5	51.9	
2500.0Hz	36.8	30.1	25.6	23.6	27.6	32.5	36.8	40.9	43.8	47.0	49.6	52.0	
3150.0Hz	33.3	26.6	22.9	21.5	24.4	28.8	33.3	38.3	41.6	44.7	47.3	49.9	
4000.0Hz	31.4	24.9	21.8	21.1	22.6	27.3	31.4	35.9	39.2	43.5	45.8	48.7	
5000.0Hz	29.3	23.6	21.3	20.7	22.0	25.1	29.3	34.1	37.4	41.7	44.6	47.6	
6300.0Hz	25.7	21.5	20.4	20.2	20.7	22.3	25.7	30.1	33.7	38.3	41.1	44.0	
8000.0Hz	21.7	19.8	19.5	19.3	19.6	20.1	21.7	26.1	28.9	33.8	37.2	40.4	
10000.0Hz	18.6	17.7	17.6	17.6	17.6	17.9	18.6	21.1	23.6	28.1	31.4	35.1	
12500.0Hz	15.9	14.6	14.6	14.7	14.5	14.8	15.9	16.5	18.3	22.4	25.9	29.3	
16000.0Hz	21.6	12.4	12.3	12.3	12.4	12.5	21.6	12.7	13.2	24.8	16.5	19.3	

Model	PFWBC-12													
Speed	H(1000)	M(800)	L(500)	500RPM	600RPM	700RPM	800RPM	900RPM	1000RPM	1100RPM	1200RPM	1300RPM	1400RPM	
Sound Power dB(A)	55.8	49.3	37.0	37.0	41.6	45.9	49.3	53.0	55.8	58.6	60.8	63.3	64.9	
Sound Power in 1/3 Octave-bands under ESP:0Pa	20.0Hz	17.6	25.9	17.8	17.8	19.1	20.2	25.9	21.4	17.6	20.6	16.7	17.2	14.7
	25.0Hz	21.6	28.0	20.1	20.1	16.5	20.1	28.0	22.0	21.6	20.5	18.3	20.5	14.8
	31.5Hz	12.4	16.7	10.9	10.9	11.5	17.5	16.7	21.8	12.4	18.7	12.7	18.5	15.4
	40.0Hz	13.3	11.9	7.3	7.3	11.7	10.9	11.9	11.6	13.3	13.7	13.1	17.9	18.8
	50.0Hz	21.7	18.4	14.1	14.1	17.1	16.9	18.4	14.7	21.7	16.6	16.6	21.9	19.0
	63.0Hz	20.6	19.3	15.8	15.8	14.3	15.0	19.3	16.8	20.6	18.1	18.2	21.2	22.8
	80.0Hz	17.1	13.8	5.7	5.7	7.7	11.7	13.8	16.4	17.1	20.1	20.2	24.3	25.6
	100.0Hz	22.2	16.1	8.1	8.1	10.0	14.5	16.1	21.4	22.2	24.1	30.4	28.9	32.9
	125.0Hz	27.2	20.5	11.4	11.4	16.2	16.8	20.5	24.9	27.2	31.2	31.1	36.2	37.3
	160.0Hz	33.2	27.7	17.4	17.4	18.8	24.8	27.7	30.2	33.2	34.8	36.0	40.5	42.5
	200.0Hz	37.8	33.3	21.3	21.3	26.9	29.2	33.3	33.7	37.8	39.7	43.9	45.0	45.8
	250.0Hz	42.4	38.0	24.8	24.8	32.0	33.4	38.0	40.6	42.4	44.0	46.6	51.0	51.6
	315.0Hz	44.6	40.3	27.2	27.2	33.1	37.1	40.3	42.5	44.6	46.3	49.8	52.9	53.5
	400.0Hz	44.8	39.5	26.4	26.4	32.0	35.4	39.5	42.2	44.8	47.4	49.4	50.0	53.2
	500.0Hz	46.3	41.8	28.9	28.9	34.4	39.1	41.8	45.0	46.3	50.7	50.5	52.9	55.6
	630.0Hz	46.7	41.5	27.9	27.9	33.2	38.0	41.5	44.6	46.7	49.3	51.6	53.3	53.5
	800.0Hz	45.0	38.8	24.1	24.1	30.9	35.0	38.8	42.4	45.0	48.1	49.7	51.2	52.6
	1000.0Hz	48.4	41.8	24.9	24.9	32.1	37.2	41.8	45.2	48.4	50.8	53.2	55.7	57.1
	1250.0Hz	44.4	37.2	20.4	20.4	26.1	31.8	37.2	41.1	44.4	48.1	50.1	52.6	53.9
	1600.0Hz	44.3	35.5	20.5	20.5	23.9	29.9	35.5	39.4	44.3	46.4	49.7	51.9	54.6
2000.0Hz	42.3	33.5	20.3	20.3	23.1	28.2	33.5	37.9	42.3	45.2	48.2	50.9	52.8	
2500.0Hz	40.3	31.7	20.9	20.9	22.3	26.5	31.7	36.5	40.3	44.3	47.4	49.9	52.4	
3150.0Hz	36.7	27.3	21.0	21.0	21.6	23.4	27.3	32.1	36.7	40.7	44.3	47.2	49.7	
4000.0Hz	34.8	25.6	21.1	21.1	21.5	22.7	25.6	29.8	34.8	39.0	42.1	45.7	48.3	
5000.0Hz	31.2	23.0	21.0	21.0	21.0	21.6	23.0	26.8	31.2	34.7	38.4	42.4	45.1	
6300.0Hz	27.0	21.3	20.7	20.7	20.8	20.9	21.3	23.3	27.0	30.6	35.1	38.6	41.3	
8000.0Hz	23.5	20.5	19.9	19.9	19.9	20.1	20.5	21.3	23.5	26.9	31.0	34.5	37.4	
10000.0Hz	19.2	18.0	18.0	18.0	18.0	18.0	18.0	18.0	19.2	21.3	24.5	27.9	30.9	
12500.0Hz	15.1	14.7	14.7	14.7	14.7	14.8	14.7	14.8	15.1	15.8	17.8	19.9	23.3	
16000.0Hz	14.4	14.5	14.5	14.5	14.1	14.2	14.5	14.5	14.4	15.5	16.3	17.7	18.9	

Model	PFWBC-15													
Speed	H(1050)	M(880)	L(750)	500RPM	600RPM	700RPM	800RPM	900RPM	1000RPM	1100RPM	1200RPM	1300RPM	1400RPM	
Sound Power dB(A)	57.0	52.4	47.8	39.0	41.5	45.9	49.6	53.1	55.9	58.0	60.7	62.6	64.6	
Sound Power in 1/3 Octave-bands under ESP:0Pa	20.0Hz	20.4	19.1	18.9	18.2	19.0	17.0	20.7	18.7	20.7	20.1	19.9	18.0	18.2
	25.0Hz	17.2	22.5	20.2	16.9	20.0	18.9	21.5	22.8	18.2	16.2	23.1	18.8	21.8
	31.5Hz	15.8	19.2	18.8	17.1	18.4	20.4	17.2	19.7	16.4	15.2	14.2	17.6	17.7
	40.0Hz	14.3	14.3	17.0	13.8	10.7	17.0	17.0	13.7	16.4	12.2	12.6	12.6	14.7
	50.0Hz	15.5	20.0	19.4	16.2	15.6	21.8	17.0	20.8	14.5	16.5	15.9	18.1	18.2
	63.0Hz	16.3	16.2	18.6	14.7	17.8	20.4	16.8	16.0	17.3	15.3	20.1	21.8	24.4
	80.0Hz	18.1	15.5	12.5	7.1	6.7	12.0	13.0	16.1	16.2	19.9	21.5	23.5	24.4
	100.0Hz	22.6	17.9	15.6	11.0	10.7	14.6	16.5	18.3	21.5	23.7	27.0	28.1	31.3
	125.0Hz	28.6	25.6	21.3	13.9	14.6	19.7	23.0	26.3	26.9	30.3	31.4	36.5	36.6
	160.0Hz	34.3	30.2	26.0	17.1	20.1	23.7	28.3	30.7	32.4	36.1	37.2	37.7	42.0
	200.0Hz	39.1	34.3	29.7	22.7	25.2	28.1	31.2	35.1	39.2	39.0	40.3	45.9	45.0
	250.0Hz	44.3	40.3	36.8	27.2	31.6	34.2	39.3	40.6	42.3	46.3	47.5	49.8	52.5
	315.0Hz	45.8	41.2	37.9	29.6	32.2	37.0	38.7	41.8	45.1	46.5	48.6	51.5	53.6
	400.0Hz	46.8	41.4	38.3	39.5	32.9	36.8	39.8	41.7	46.6	47.0	49.1	50.2	53.1
	500.0Hz	48.1	44.0	39.5	28.1	34.2	38.5	40.5	44.8	47.8	48.4	51.2	52.0	53.0
	630.0Hz	47.3	43.7	38.8	25.3	31.6	36.7	40.9	44.4	46.6	48.1	50.0	52.4	52.0
	800.0Hz	46.7	42.4	36.7	25.4	32.0	34.5	38.9	43.3	45.8	47.6	51.2	52.2	53.9
	1000.0Hz	48.7	43.3	38.1	24.6	31.8	36.0	40.3	44.1	47.6	49.8	52.3	54.8	56.1
	1250.0Hz	46.0	40.6	35.0	20.9	28.0	32.8	37.2	41.4	44.8	47.3	49.6	51.9	54.5
	1600.0Hz	45.2	40.3	34.9	19.5	24.8	32.5	37.3	41.1	43.2	47.1	50.1	52.2	54.0
2000.0Hz	43.8	38.4	32.1	20.0	23.1	29.2	35.0	39.2	42.0	45.7	48.3	50.3	53.0	
2500.0Hz	43.5	36.8	30.0	20.4	22.2	27.3	32.7	37.8	41.7	45.3	48.4	50.6	52.7	
3150.0Hz	39.7	32.8	26.4	20.4	21.1	24.0	28.8	33.8	37.8	41.6	44.8	47.8	50.2	
4000.0Hz	37.2	30.4	24.4	20.7	21.0	22.7	26.1	31.5	35.4	38.9	42.7	45.4	48.5	
5000.0Hz	34.4	27.7	22.9	20.7	20.9	21.5	24.2	28.6	32.4	36.4	40.3	43.0	45.9	
6300.0Hz	30.0	24.0	21.2	20.1	20.4	20.6	21.7	24.5	27.9	32.2	36.2	39.1	42.3	
8000.0Hz	25.4	20.6	19.6	19.1	19.3	19.5	19.7	20.9	23.3	27.4	31.6	35.5	38.6	
10000.0Hz	20.3	17.9	17.7	17.6	17.5	17.7	17.7	18.0	19.1	21.5	25.7	28.9	32.4	
12500.0Hz	15.9	14.9	14.7	14.8	15.5	14.6	14.7	14.9	15.3	16.5	19.5	22.2	25.8	
16000.0Hz	13.8	13.8	13.4	14.0	22.5	13.4	13.4	13.9	13.5	14.1	15.0	17.0	19.5	

Model	PFWBC-18													
Speed	H(1150)	M(950)	L(800)	500RPM	600RPM	700RPM	800RPM	900RPM	1000RPM	1100RPM	1200RPM	1300RPM	1400RPM	
Sound Power dB(A)	60.0	54.8	50.1	39.0	41.8	46.1	50.1	53.6	56.0	58.8	61.2	63.2	65.1	
Sound Power in 1/3 Octave-bands under ESP:0Pa	20.0Hz	20.5	20.5	17.6	18.9	21.1	15.5	17.6	24.1	16.9	15.5	25.5	22.1	27.1
	25.0Hz	24.1	21.9	17.9	23.2	20.1	15.1	17.9	27.1	16.7	18.5	29.8	22.6	27.9
	31.5Hz	23.2	20.2	21.8	15.0	17.6	13.1	21.8	21.0	19.4	22.3	24.1	22.0	29.2
	40.0Hz	24.6	21.3	22.5	12.4	15.4	14.2	22.5	23.6	19.0	23.9	25.3	20.6	25.1
	50.0Hz	22.3	17.3	17.5	18.0	17.2	17.9	17.5	16.5	18.2	21.3	23.3	23.0	27.6
	63.0Hz	20.7	19.8	18.7	16.3	14.6	16.4	18.7	18.8	20.7	19.2	22.3	23.6	31.6
	80.0Hz	23.5	18.8	16.2	5.6	9.3	11.1	16.2	18.9	18.6	20.8	26.2	23.6	30.5
	100.0Hz	26.0	22.4	18.7	10.6	13.4	15.5	18.7	19.9	24.8	24.3	27.8	29.3	32.5
	125.0Hz	33.4	27.2	21.2	11.8	15.9	18.2	21.2	24.5	29.9	33.3	33.5	35.1	36.4
	160.0Hz	36.7	31.2	26.3	15.8	19.7	24.5	26.3	29.3	33.1	35.9	37.6	39.3	43.0
	200.0Hz	40.3	36.3	33.5	22.4	24.8	27.4	33.5	34.1	38.5	39.8	40.8	43.6	47.4
	250.0Hz	47.1	42.1	38.9	28.5	31.0	34.8	38.9	41.2	42.9	46.6	47.6	49.7	51.7
	315.0Hz	48.6	44.5	39.6	28.5	33.2	35.8	39.6	43.3	45.7	47.1	50.2	52.3	54.5
	400.0Hz	47.5	44.0	39.0	33.5	32.7	36.9	39.0	43.1	44.9	46.9	48.1	50.9	53.4
	500.0Hz	51.0	46.8	42.8	27.2	33.6	38.9	42.8	46.2	47.5	50.7	51.3	52.0	55.7
	630.0Hz	50.8	46.2	41.8	26.3	32.0	37.8	41.8	45.3	47.2	49.4	52.2	53.0	54.0
	800.0Hz	49.3	44.0	38.7	24.1	30.4	34.0	38.7	43.3	44.7	48.7	49.8	51.5	53.8
	1000.0Hz	51.3	45.8	41.1	23.6	30.9	36.5	41.1	44.5	47.1	50.5	52.1	55.5	57.1
	1250.0Hz	49.2	43.0	37.4	20.9	27.6	33.8	37.4	41.7	44.2	48.1	50.2	52.4	53.9
	1600.0Hz	48.6	44.1	39.0	21.0	25.9	33.0	39.0	42.2	45.9	47.3	49.9	52.0	54.9
2000.0Hz	48.1	42.5	35.7	20.4	24.0	29.8	35.7	40.7	44.3	46.9	49.4	51.8	53.7	
2500.0Hz	46.9	39.5	32.6	20.5	22.6	27.5	32.6	37.4	41.6	45.3	48.4	51.2	52.8	
3150.0Hz	43.8	36.3	28.9	20.9	21.6	24.8	28.9	33.9	38.6	42.1	45.5	48.8	50.9	
4000.0Hz	42.3	35.0	27.2	20.9	21.5	23.9	27.2	33.3	36.7	40.7	43.9	47.0	49.4	
5000.0Hz	39.1	31.4	24.6	20.7	21.1	22.6	24.6	29.5	33.3	37.7	40.6	43.6	46.0	
6300.0Hz	35.6	28.0	22.2	20.7	20.7	21.1	22.2	26.2	29.8	34.0	37.3	40.3	42.6	
8000.0Hz	31.4	24.4	20.7	19.8	20.1	20.2	20.7	23.0	25.9	30.0	32.9	37.1	39.6	
10000.0Hz	24.8	19.6	18.1	18.0	17.9	18.0	18.1	18.8	20.3	23.2	26.3	30.0	32.5	
12500.0Hz	18.8	15.4	14.8	15.5	14.8	14.8	14.8	14.9	15.9	17.6	19.9	23.0	25.6	
16000.0Hz	16.5	14.7	14.1	22.4	13.3	13.5	14.1	14.4	14.9	15.9	17.0	18.7	20.3	

Model	PFWBC-24R													
Speed	H(1150)	M(1000)	L(850)	500RPM	600RPM	700RPM	800RPM	900RPM	1000RPM	1100RPM	1200RPM	1300RPM	1400RPM	
Sound Power dB(A)	60.2	56.3	51.8	36.2	41.7	46.1	50.0	53.6	56.3	58.9	61.4	63.6	65.7	
Sound Power in 1/3 Octave-bands under ESP:0Pa	20.0Hz	17.6	18.1	19.2	13.4	21.3	15.5	19.4	19.0	18.1	15.2	19.9	21.6	19.4
	25.0Hz	15.5	18.1	18.4	16.4	21.8	17.3	15.1	21.8	18.1	14.7	16.2	20.0	16.8
	31.5Hz	15.6	13.9	15.7	12.5	12.2	15.6	13.3	18.2	13.9	12.8	18.4	18.6	14.9
	40.0Hz	12.3	11.6	13.6	13.2	15.8	12.5	11.6	15.6	11.6	9.8	14.8	13.4	16.6
	50.0Hz	19.2	18.1	17.9	20.5	17.7	14.0	19.3	16.5	18.1	18.4	20.0	19.2	20.2
	63.0Hz	18.6	16.9	16.4	19.9	16.3	13.9	19.1	13.7	16.9	19.9	17.4	19.4	23.1
	80.0Hz	22.3	19.2	17.1	7.3	10.2	10.1	17.1	17.2	19.2	21.5	23.1	27.1	25.6
	100.0Hz	27.3	24.4	21.0	10.7	11.8	15.8	20.4	21.6	24.4	26.6	28.0	30.1	31.9
	125.0Hz	33.3	28.7	26.6	13.4	18.1	20.5	26.5	26.7	28.7	32.0	34.6	37.1	38.2
	160.0Hz	38.2	35.1	30.7	18.5	25.4	25.9	29.5	31.8	35.1	37.5	38.9	41.5	41.5
	200.0Hz	42.7	38.6	36.5	22.9	30.1	31.4	34.9	38.0	38.6	41.6	43.7	47.4	48.1
	250.0Hz	47.7	44.5	39.7	26.5	33.5	35.8	37.9	41.5	44.5	46.8	48.7	50.7	52.9
	315.0Hz	48.5	45.1	40.8	27.2	36.6	35.9	39.4	42.2	45.1	48.0	49.0	51.4	53.3
	400.0Hz	47.5	43.4	40.1	27.4	35.8	36.8	38.4	41.7	43.4	47.1	47.8	49.8	52.1
	500.0Hz	49.8	47.5	44.0	26.1	37.2	38.7	42.0	46.0	47.5	48.6	50.9	53.0	53.7
	630.0Hz	51.6	48.1	44.5	26.0	37.0	38.4	43.1	45.9	48.1	50.5	52.6	54.3	55.7
	800.0Hz	48.8	44.8	41.4	21.9	34.2	33.9	39.2	43.5	44.8	47.2	50.5	51.8	53.7
	1000.0Hz	52.0	47.4	42.8	22.4	32.0	36.6	40.9	44.7	47.4	50.9	53.0	55.4	57.3
	1250.0Hz	49.7	45.6	40.2	20.3	35.6	33.0	38.0	42.4	45.6	48.6	50.8	53.7	55.3
	1600.0Hz	49.5	45.0	39.4	19.2	38.0	31.3	37.3	41.4	45.0	47.9	51.1	53.5	55.4
2000.0Hz	48.0	42.3	36.7	19.8	34.3	28.5	34.4	38.9	42.3	46.3	49.7	52.0	54.0	
2500.0Hz	46.5	41.5	35.0	20.9	27.7	27.6	32.7	37.3	41.5	44.8	48.3	51.1	53.8	
3150.0Hz	43.9	38.0	31.5	19.8	31.3	24.0	29.3	33.8	38.0	42.1	45.6	48.4	51.0	
4000.0Hz	41.5	35.7	28.8	19.7	29.8	22.4	26.6	31.0	35.7	40.0	43.1	46.1	48.8	
5000.0Hz	39.5	33.5	26.9	19.9	27.6	21.1	24.9	28.9	33.5	37.5	41.5	45.0	47.4	
6300.0Hz	35.5	29.2	23.6	19.8	28.2	20.0	22.2	25.1	29.2	33.4	37.6	41.1	43.9	
8000.0Hz	31.3	25.2	21.3	18.8	30.7	19.3	20.7	21.9	25.2	29.4	33.1	37.4	40.6	
10000.0Hz	24.7	19.4	17.9	16.8	27.0	16.9	17.9	17.8	19.4	22.8	26.6	30.3	33.5	
12500.0Hz	18.5	14.8	14.4	13.9	25.2	13.7	14.9	13.9	14.8	16.8	20.2	23.4	26.4	
16000.0Hz	14.2	12.2	12.4	12.4	22.1	11.6	12.9	11.9	12.2	13.5	14.9	16.6	18.8	

Model	PFWBC-30													
Speed	H(12150)	M(11000)	L(950)	500RPM	600RPM	700RPM	800RPM	900RPM	1000RPM	1100RPM	1200RPM	1300RPM	1400RPM	
Sound Power dB(A)	62.5	58.9	55.0	36.2	41.7	46.1	50.0	53.6	56.3	58.9	61.4	63.6	65.7	
Sound Power in 1/3 Octave-bands under ESP:0Pa	20.0Hz	20.8	15.2	18.6	13.4	21.3	15.5	19.4	19.0	18.1	15.2	19.9	21.6	19.4
	25.0Hz	18.1	14.7	19.9	16.4	21.8	17.3	15.1	21.8	18.1	14.7	16.2	20.0	16.8
	31.5Hz	18.5	12.8	16.1	12.5	12.2	15.6	13.3	18.2	13.9	12.8	18.4	18.6	14.9
	40.0Hz	14.1	9.8	13.6	13.2	15.8	12.5	11.6	15.6	11.6	9.8	14.8	13.4	16.6
	50.0Hz	19.6	18.4	17.3	20.5	17.7	14.0	19.3	16.5	18.1	18.4	20.0	19.2	20.2
	63.0Hz	18.4	19.9	15.3	19.9	16.3	13.9	19.1	13.7	16.9	19.9	17.4	19.4	23.1
	80.0Hz	25.1	21.5	18.2	7.3	10.2	10.1	17.1	17.2	19.2	21.5	23.1	27.1	25.6
	100.0Hz	29.1	26.6	23.0	10.7	11.8	15.8	20.4	21.6	24.4	26.6	28.0	30.1	31.9
	125.0Hz	35.8	32.0	27.7	13.4	18.1	20.5	26.5	26.7	28.7	32.0	34.6	37.1	38.2
	160.0Hz	40.2	37.5	33.4	18.5	25.4	25.9	29.5	31.8	35.1	37.5	38.9	41.5	41.5
	200.0Hz	45.6	41.6	38.3	22.9	30.1	31.4	34.9	38.0	38.6	41.6	43.7	47.4	48.1
	250.0Hz	49.7	46.8	43.0	26.5	33.5	35.8	37.9	41.5	44.5	46.8	48.7	50.7	52.9
	315.0Hz	50.2	48.0	43.7	27.2	36.6	35.9	39.4	42.2	45.1	48.0	49.0	51.4	53.3
	400.0Hz	48.8	47.1	42.6	27.4	35.8	36.8	38.4	41.7	43.4	47.1	47.8	49.8	52.1
	500.0Hz	52.0	48.6	46.8	26.1	37.2	38.7	42.0	46.0	47.5	48.6	50.9	53.0	53.7
	630.0Hz	53.5	50.5	47.0	26.0	37.0	38.4	43.1	45.9	48.1	50.5	52.6	54.3	55.7
	800.0Hz	51.2	47.2	44.2	21.9	34.2	33.9	39.2	43.5	44.8	47.2	50.5	51.8	53.7
	1000.0Hz	54.2	50.9	46.1	22.4	32.0	36.6	40.9	44.7	47.4	50.9	53.0	55.4	57.3
	1250.0Hz	52.3	48.6	44.0	20.3	35.6	33.0	38.0	42.4	45.6	48.6	50.8	53.7	55.3
	1600.0Hz	52.3	47.9	43.2	19.2	38.0	31.3	37.3	41.4	45.0	47.9	51.1	53.5	55.4
	2000.0Hz	50.9	46.3	40.6	19.8	34.3	28.5	34.4	38.9	42.3	46.3	49.7	52.0	54.0
	2500.0Hz	49.7	44.8	39.4	20.9	27.7	27.6	32.7	37.3	41.5	44.8	48.3	51.1	53.8
	3150.0Hz	47.0	42.1	35.9	19.8	31.3	24.0	29.3	33.8	38.0	42.1	45.6	48.4	51.0
	4000.0Hz	44.6	40.0	33.4	19.7	29.8	22.4	26.6	31.0	35.7	40.0	43.1	46.1	48.8
5000.0Hz	43.3	37.5	31.2	19.9	27.6	21.1	24.9	28.9	33.5	37.5	41.5	45.0	47.4	
6300.0Hz	39.3	33.4	27.2	19.8	28.2	20.0	22.2	25.1	29.2	33.4	37.6	41.1	43.9	
8000.0Hz	35.3	29.4	23.5	18.8	30.7	19.3	20.7	21.9	25.2	29.4	33.1	37.4	40.6	
10000.0Hz	28.5	22.8	18.6	16.8	27.0	16.9	17.9	17.8	19.4	22.8	26.6	30.3	33.5	
12500.0Hz	21.8	16.8	14.4	13.9	25.2	13.7	14.9	13.9	14.8	16.8	20.2	23.4	26.4	
16000.0Hz	15.7	13.5	12.0	12.4	22.1	11.6	12.9	11.9	12.2	13.5	14.9	16.6	18.8	

Model	PFWBC-36
-------	----------

Speed	H(1250)	M(1100)	L(950)	500RPM	600RPM	700RPM	800RPM	900RPM	1000RPM	1100RPM	1200RPM	1300RPM	1400RPM	
Sound Power dB(A)	65.0	61.1	57.1	39.2	43.8	48.0	52.3	55.5	58.6	61.1	63.9	66.0	68.1	
Sound Power in 1/3 Octave-bands under ESP:0Pa	20.0Hz	18.3	9.3	13.2	8.0	10.6	4.9	15.2	13.6	12.9	9.3	18.8	17.9	17.3
	25.0Hz	21.2	14.5	19.5	8.5	11.5	8.0	13.1	23.0	16.1	14.5	18.4	23.9	19.9
	31.5Hz	21.6	13.6	14.3	8.6	8.9	8.3	14.6	13.0	15.5	13.6	21.7	21.5	27.9
	40.0Hz	25.9	16.3	18.6	13.4	14.4	9.8	14.6	18.8	18.3	16.3	21.5	30.3	23.8
	50.0Hz	29.5	20.4	17.5	10.5	15.1	9.0	16.4	16.6	18.3	20.4	23.4	35.7	27.4
	63.0Hz	29.6	23.0	19.9	9.4	9.3	13.6	21.0	17.9	21.8	23.0	25.6	33.5	31.2
	80.0Hz	31.1	26.0	22.0	7.1	9.7	14.2	19.4	21.0	23.1	26.0	28.3	34.0	33.2
	100.0Hz	33.7	29.6	25.0	9.7	13.2	17.4	23.8	23.4	26.5	29.6	31.4	36.0	36.3
	125.0Hz	38.1	35.6	30.8	12.9	19.5	22.5	26.6	28.8	32.7	35.6	36.2	40.1	41.5
	160.0Hz	42.6	40.8	35.3	19.8	23.8	26.2	31.4	34.7	35.9	40.8	41.3	43.9	46.6
	200.0Hz	47.2	44.2	39.4	26.2	27.7	31.3	35.6	38.1	40.8	44.2	45.6	48.8	49.9
	250.0Hz	52.6	47.7	43.6	27.6	33.1	36.8	39.9	42.2	45.0	47.7	51.2	53.9	53.8
	315.0Hz	54.2	51.7	47.5	30.3	35.8	39.5	42.8	45.6	49.5	51.7	53.3	55.1	57.3
	400.0Hz	53.8	50.0	46.5	31.7	35.4	40.1	41.9	45.0	47.9	50.0	53.1	54.5	56.9
	500.0Hz	54.6	50.3	48.8	29.3	35.4	39.6	43.9	48.5	49.1	50.3	53.9	55.3	57.5
	630.0Hz	54.9	52.0	48.3	31.2	35.0	39.0	43.9	47.5	49.2	52.0	54.0	55.8	57.3
	800.0Hz	53.1	49.3	45.6	24.7	31.5	36.1	40.9	44.2	47.0	49.3	51.8	54.4	56.1
	1000.0 Hz	57.3	53.3	49.5	26.4	34.2	39.8	44.2	47.7	51.2	53.3	55.8	58.7	61.2
	1250.0 Hz	53.5	49.8	45.4	22.1	28.8	34.8	39.5	43.9	47.0	49.8	52.0	55.1	57.1
	1600.0 Hz	53.7	50.2	45.0	21.0	27.7	33.3	39.2	43.4	46.7	50.2	52.4	54.9	57.6
2000.0 Hz	52.9	48.6	43.9	21.7	26.1	31.7	37.7	41.7	46.0	48.6	51.7	54.0	56.7	
2500.0 Hz	51.4	47.1	41.5	22.5	25.3	29.8	35.0	39.3	43.8	47.1	50.4	52.4	55.3	
3150.0 Hz	48.6	43.5	38.4	21.6	23.2	26.0	31.2	36.2	40.5	43.5	46.9	50.3	53.1	
4000.0 Hz	46.6	40.8	35.8	21.2	21.6	23.3	28.1	33.7	38.0	40.8	45.1	48.2	50.8	
5000.0 Hz	43.4	37.6	32.0	21.1	21.4	22.3	24.9	29.5	34.6	37.6	41.7	45.0	48.0	
6300.0 Hz	38.8	32.8	27.5	20.7	20.5	20.8	22.0	25.1	29.8	32.8	37.1	40.4	43.8	
8000.0 Hz	34.3	28.2	23.6	19.9	19.8	20.1	20.4	22.1	25.1	28.2	32.5	36.1	39.2	
10000.0 Hz	26.6	21.5	19.1	17.9	18.1	17.8	18.0	18.4	19.8	21.5	25.0	28.3	31.8	
12500.0 Hz	20.4	16.2	15.2	14.7	14.6	14.7	14.7	14.8	15.6	16.2	18.8	22.0	24.7	
16000.0 Hz	15.1	13.2	12.5	12.1	13.0	12.4	12.1	12.4	12.6	13.2	14.5	15.7	18.2	

Model	PFWBC-40															
Speed	H(1300)	M(1150)	L(950)	300RPM	400RPM	500RPM	600RPM	700RPM	800RPM	900RPM	1000RPM	1100RPM	1200RPM	1300RPM	1400RPM	
Sound Power dB(A)	66.1	62.7	57.4	34.7	36.2	41.8	44.3	49.2	52.8	55.9	58.9	61.5	63.9	66.1	67.7	
Sound Power in 1/3 Octave-bands under ESP:OPA	20.0Hz	16.6	19.0	16.7	16.4	11.9	17.2	19.0	20.0	17.4	20.2	13.2	19.3	18.6	16.6	21.1
	25.0Hz	14.0	17.6	20.2	13.8	12.8	17.5	18.0	20.2	16.3	22.5	17.9	16.6	18.6	14.0	22.0
	31.5Hz	16.4	13.9	18.2	16.1	14.9	14.3	17.5	15.4	20.8	18.9	17.4	11.7	16.2	16.4	15.6
	40.0Hz	15.1	14.2	13.5	20.7	11.3	10.5	13.1	11.5	15.2	13.6	13.4	12.3	16.2	15.1	18.6
	50.0Hz	17.0	17.4	16.9	19.6	19.5	13.6	17.7	16.8	16.9	18.2	15.6	16.4	18.4	17.0	20.2
	63.0Hz	23.2	19.8	20.1	18.2	15.2	12.1	15.3	15.3	15.4	22.2	18.1	18.5	21.2	23.2	24.5
	80.0Hz	26.1	24.1	19.3	5.7	7.2	7.9	11.7	12.1	15.7	19.1	19.4	22.8	25.3	26.1	28.1
	100.0Hz	31.8	27.7	24.1	9.2	9.7	10.5	14.8	17.3	19.1	22.5	25.7	25.9	29.5	31.8	32.7
	125.0Hz	37.5	33.1	30.1	15.3	11.7	15.1	16.4	24.3	26.1	28.2	31.9	32.5	33.7	37.5	37.6
	160.0Hz	43.9	40.9	36.1	13.0	16.8	19.9	23.7	26.8	30.8	34.4	37.7	39.2	42.5	43.9	46.2
	200.0Hz	47.3	44.9	39.5	16.2	19.0	24.6	29.2	33.2	37.4	38.6	40.3	43.9	45.9	47.3	49.5
	250.0Hz	53.4	48.0	43.4	19.5	20.8	26.9	32.5	35.9	38.3	43.2	43.6	47.1	48.8	53.4	53.4
	315.0Hz	56.7	52.8	47.5	20.1	25.2	31.6	36.3	41.0	42.8	46.4	48.5	51.3	54.2	56.7	57.1
	400.0Hz	54.6	51.1	46.5	25.4	26.6	38.3	36.4	40.2	42.3	44.1	48.9	49.5	52.7	54.6	55.4
	500.0Hz	54.3	51.4	46.9	15.7	20.6	28.4	34.0	40.2	43.1	46.1	47.8	50.3	52.5	54.3	55.7
	630.0Hz	55.3	53.1	49.5	28.3	26.2	30.6	36.6	41.2	44.7	48.3	50.8	52.4	53.7	55.3	57.5
	800.0Hz	54.4	51.8	46.7	17.1	18.4	26.4	32.6	37.7	41.7	45.0	48.4	50.8	52.9	54.4	56.3
	1000.0 Hz	58.8	55.2	49.9	18.4	20.6	27.4	34.0	40.8	45.0	48.2	51.6	54.0	56.5	58.8	60.4
	1250.0 Hz	54.9	51.4	45.7	17.9	17.9	22.6	28.9	35.8	40.3	43.7	47.6	49.8	53.1	54.9	57.0
	1600.0 Hz	55.6	51.2	45.7	18.1	18.3	21.7	28.0	34.7	40.5	43.9	47.5	50.0	52.5	55.6	57.3
	2000.0 Hz	54.5	50.8	44.4	19.7	19.5	21.2	25.7	33.0	38.5	42.4	46.3	49.4	52.2	54.5	56.3
	2500.0 Hz	53.8	49.8	42.9	20.4	20.5	21.5	24.7	30.7	36.2	40.6	45.2	48.4	51.3	53.8	56.1
	3150.0 Hz	50.9	46.5	39.0	20.7	20.9	21.6	22.6	26.8	32.0	36.4	41.6	45.1	47.9	50.9	53.2
4000.0 Hz	48.7	44.3	36.4	20.9	20.7	20.9	21.6	24.6	29.4	33.8	39.0	42.5	46.0	48.7	51.4	
5000.0 Hz	47.4	41.8	34.1	21.1	20.9	21.0	21.4	23.5	27.3	31.6	36.6	40.2	43.4	47.4	49.8	
6300.0 Hz	43.0	37.8	29.8	20.3	20.7	20.2	20.4	21.2	23.4	27.1	32.5	36.0	39.6	43.0	45.6	
8000.0 Hz	39.1	33.9	25.7	19.3	19.4	19.1	19.5	19.5	20.8	23.3	28.0	32.3	35.5	39.1	42.0	
10000.0 Hz	32.2	26.6	20.1	17.5	17.5	17.5	17.5	17.5	17.8	18.8	21.3	24.8	28.4	32.2	35.3	
12500.0 Hz	25.5	20.1	15.7	14.7	17.1	14.6	14.7	14.7	14.8	15.1	16.3	18.7	21.4	25.5	28.5	
16000.0 Hz	20.0	19.1	18.8	20.0	26.3	19.9	20.0	19.2	19.2	18.7	18.9	18.9	19.2	20.0	21.2	

B. Installation

B.1. Safety Precautions

- When installing, performing maintenance or servicing Polar Air fan coil units observe the precautions stated in this manual as well as those stated on the labels attached to the unit.
- Ensure all local and national safety codes, laws, regulations, as well as general electrical and mechanical safety guidelines are followed for installation, maintenance and service.
- The appliance is for indoor use only.
- Ensure the correct power supply is provided.
- If the power supply cord is damaged, it must be replaced by qualified personnel.
- Installing and servicing fan coil unit should be performed by qualified service personnel only.
- This appliance is not intended for use by persons (including children) with reduced physical, sensory or mental capabilities, or persons lacking in experience and knowledge of the appliance, unless they have been given supervision or instruction concerning it.
- User of this appliance is responsible for his/her own safety.
- Warranty shall be voided if installation instructions and safety precaution stated in this manual are not observed.
- Never cut off the mains supply when unit is under operation. The unit should only be switched off by using the ON-OFF button on the control interface.
- During connections, select pipe pliers according to pipe diameter to avoid damaging units over forced.
- Untreated frozen water and cooling water may cause dirt accumulation and corrosion. Suggest using treated water. Suggested working water pressure is below 1.6 Mpa.
- When units are in cooling mode, suggested freezing water degree is $\geq 7^{\circ}\text{C}$; When units are in heating mode, suggested hot water degree is $\leq 60^{\circ}\text{C}$.
- Condensate water pipe, water connection pipe, water connectors and solenoid valve body must remain heat to avoid condensation.

CAUTIONS

Before any service or maintenance operations turn off the mains electrical supply.

DO NOT turn OFF the main power supply when the unit is operating. Turn off the unit BEFORE turning off the main power

B.2. Installation and Location

The unit location should be established by the installation designer, services engineer or by a technically competent person before installation. It should take into account technical requirements as well as the relevant current laws and regulations. The fan coil should be installed by a qualified company, also in accordance with the relevant laws and regulations of the country of installation.

The fan coils are designed for exposed installation. All the models are designed to be floor free standing, wall mounted or suspended from the ceiling. Installation should allow the treated air to circulate freely throughout the room and leave sufficient space to access the unit, in order to carry out maintenance or servicing operations.

FOR FLOOR FREE STANDING

1. Open the top left and right covers to loosen the 8 screws.
2. Lift and remove the cover.
3. Install the unit on the wall
4. Complete the hydraulic connection and check for leakage.
5. Complete the electrical connection as shown in the wiring diagrams.
6. Remount the cover.

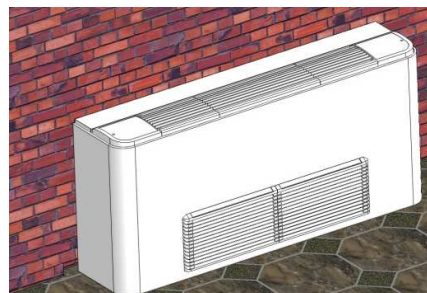

FOR WALL-MOUNTED WITH BOTTOM RETURN

1. Open the top left and right covers to loosen the 8 screws
2. Lift and remove the cover.
3. Keep a minimum clearance of 80mm from the floor.
4. Secure the mounting brackets to the wall, then suspend the unit by the mounting brackets, as shown in figure.
5. Complete the hydraulic connection and check for leakage.
6. Complete the electrical connection as shown in the wiring diagrams.
7. Remount the cover.

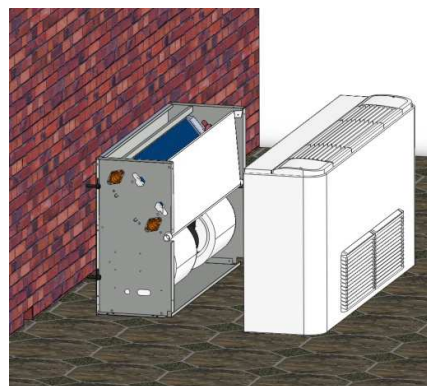

FOR CEILING-MOUNTED

1. Open the top left and right covers to loosen the 8 screws.
2. Lift and remove the cover.
3. Secure the mounting brackets to the ceiling, then suspend the unit by the mounting brackets. To correctly position flanges and brackets, see the dimensional data.
4. Complete the hydraulic connection and check for leakage.
5. Complete the electrical connection as shown in the wiring diagrams. Make electrical connection as shown in the wiring diagrams.
6. Remount the cover.

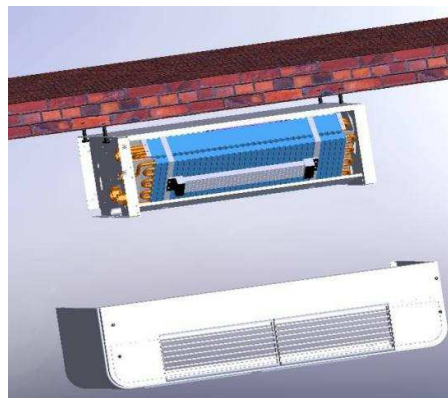

B.3. Piping Connections

The fan coils have been designed and made for installation in heating and air-conditioning systems. The characteristics of the water fittings are given below:

Main pipes connection

The position of the water fittings may be reversed from left to right during installation.

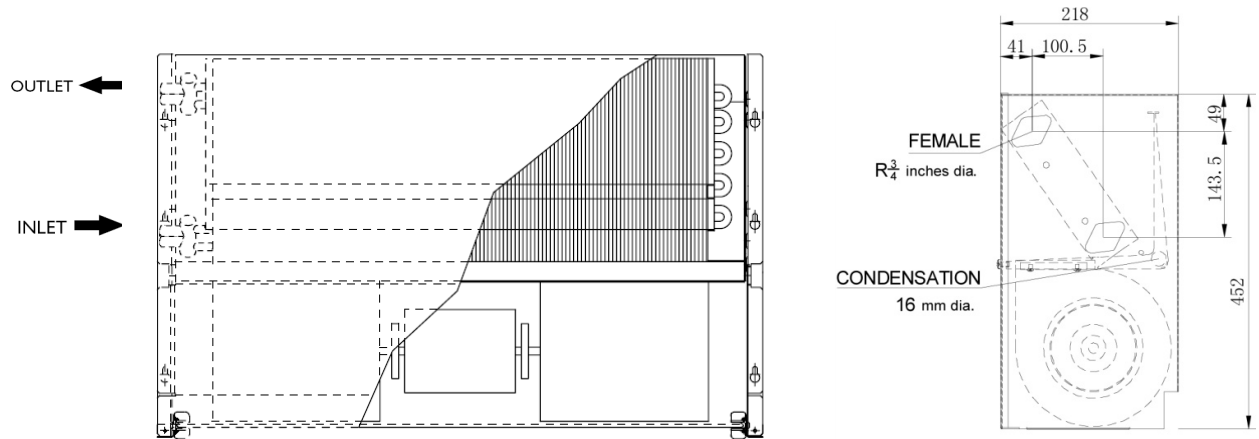

Installation diagram of water connections

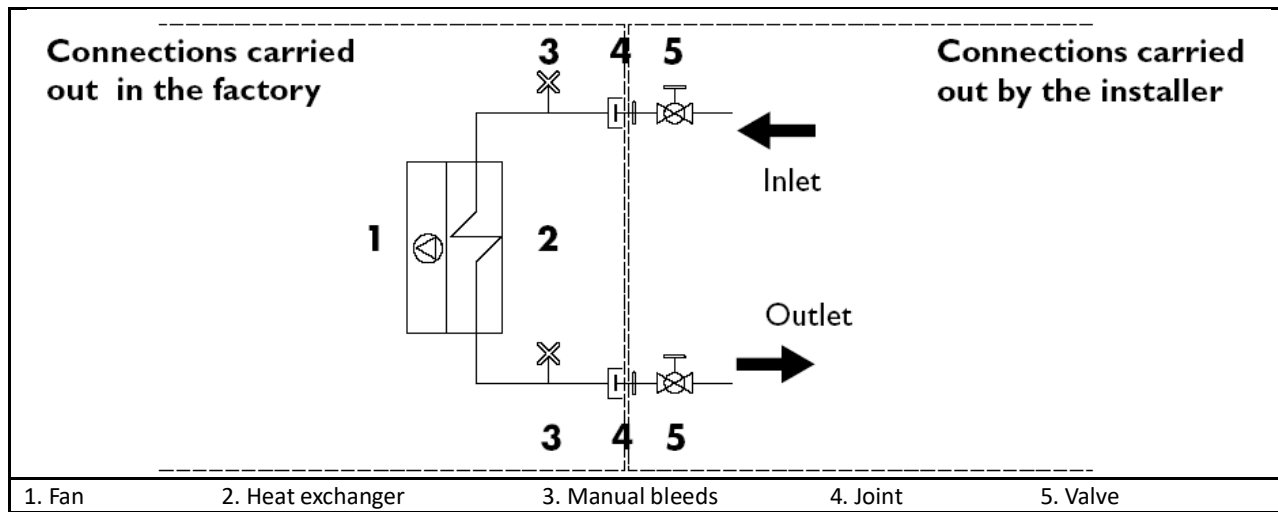

Attach the connections by tightening the fan coil fitting using 2 wrenches.

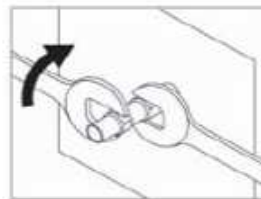

CONDENSATE DRAINAGE

Fan coils are fitted with a condensate-collecting tray to which a drainpipe can be connected. Connect an insulated drainage pipe (inside ϕ 16 mm.) to the hole of the tray and direct it towards a suitable drain

Notes:

- i. Check that the condensation flows out regularly into the tray.
- ii. The drainage pipe should have a 2% slope towards the drain.
- iii. Check all the joints for leaks.
- iv. Apply heat-insulating material to the joints.

B.4. Coil Direction Interchange

Step 1: Remove the front cabinet.

Step 2: Remove 2 screws on the coil's metal plate.

Step 3: Remove 8 screws from both sides of the coil, then take out coil.

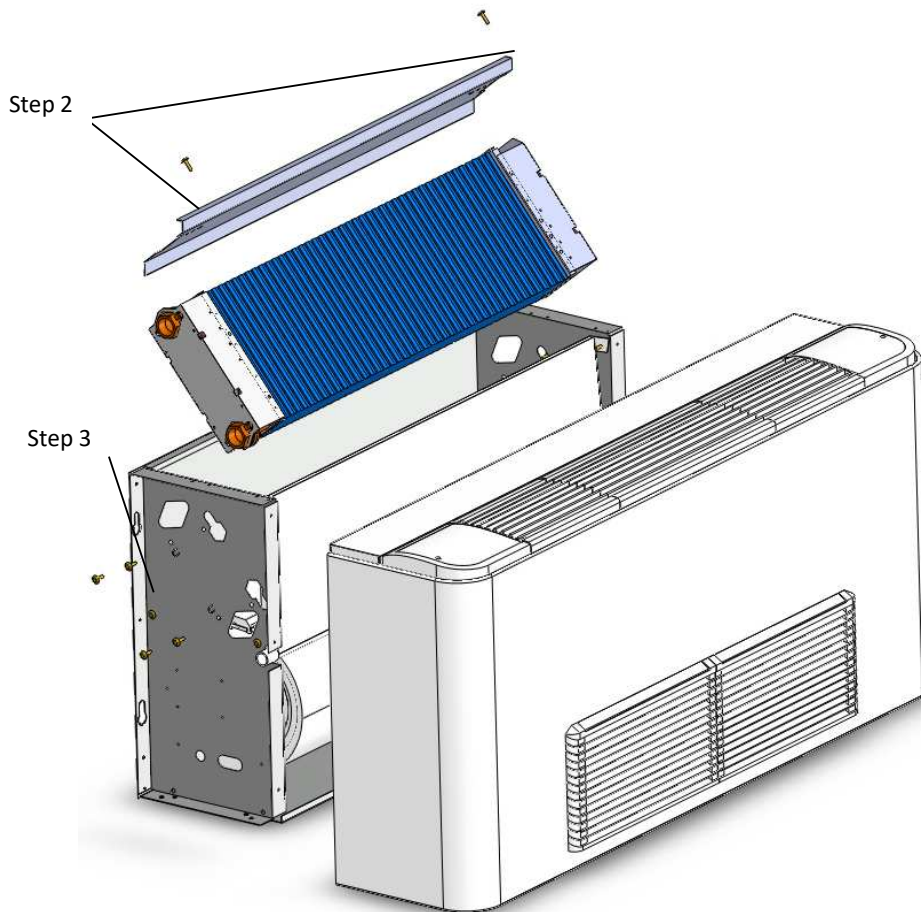

Step 4: Change the coil direction and screw back into the casing. Install the front cabinet.

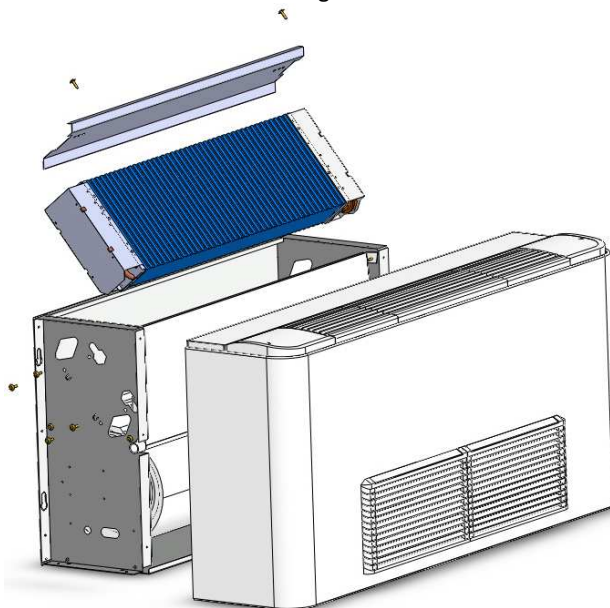

B.5. Electrical Connection

1. Wiring connection must be done according to the wiring diagram on the unit.
2. The unit must be GROUNDED well.
3. An appropriate strain relief device must be used to attach the power wires to the terminal box.
4. A 20 mm hole is designed on the terminal box for field installation of the strain relief device.
5. Field wiring must be complied with the national security regulations.
6. A main switch or other means for disconnection, having a contact separation in all poles, must be incorporated in the fixed wiring in accordance with the relevant local and national legislation.

B.6. Valve and External Drain Pan Installation

Horizontal type

Piping for 2-Pipe System

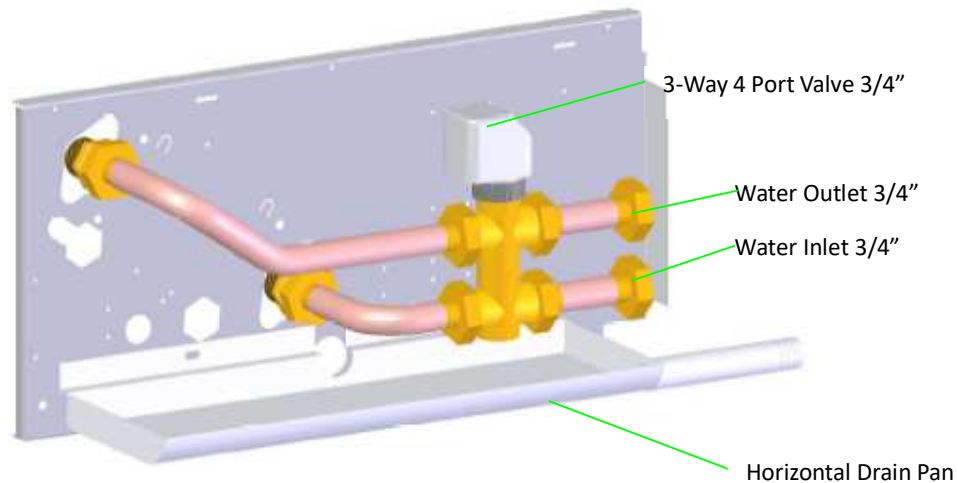

Piping for 4-Pipe System

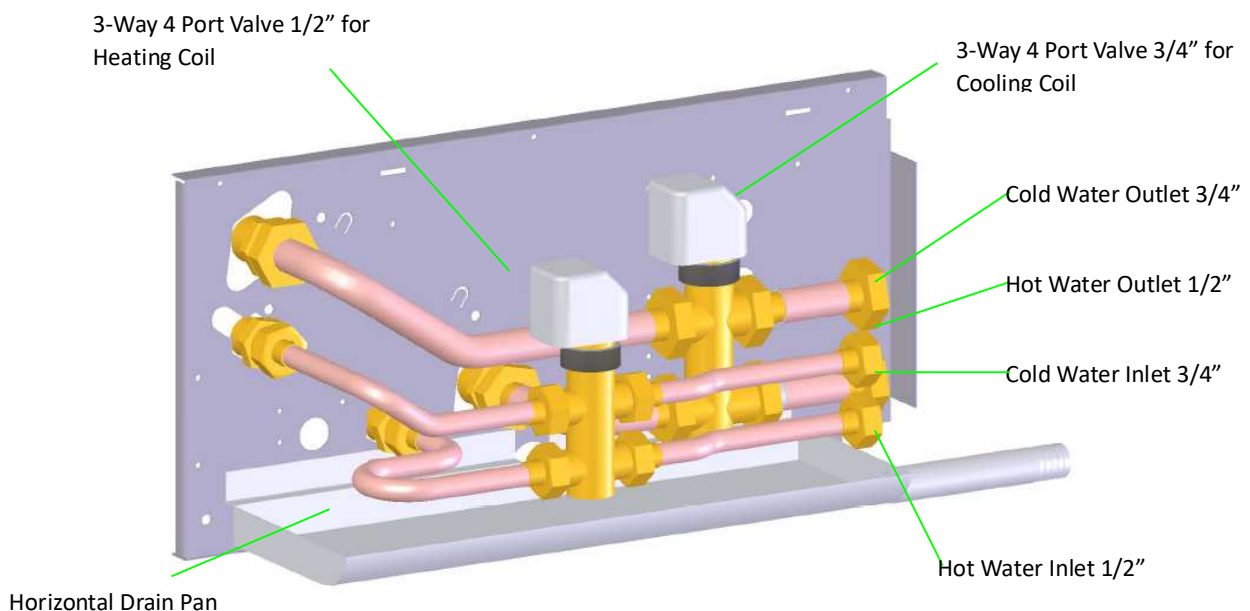

Vertical type
Piping for 2-Pipe System

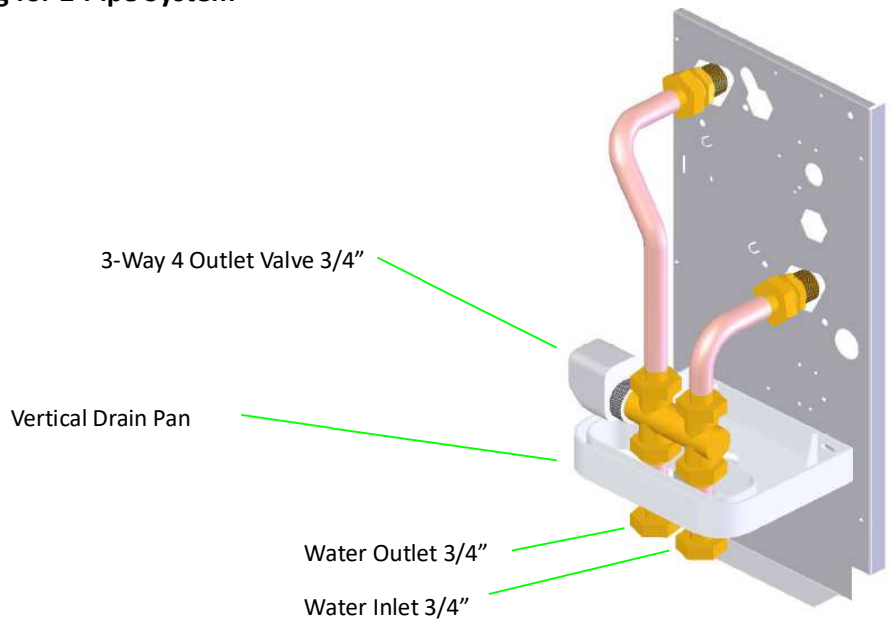

Piping for 4-Pipe System

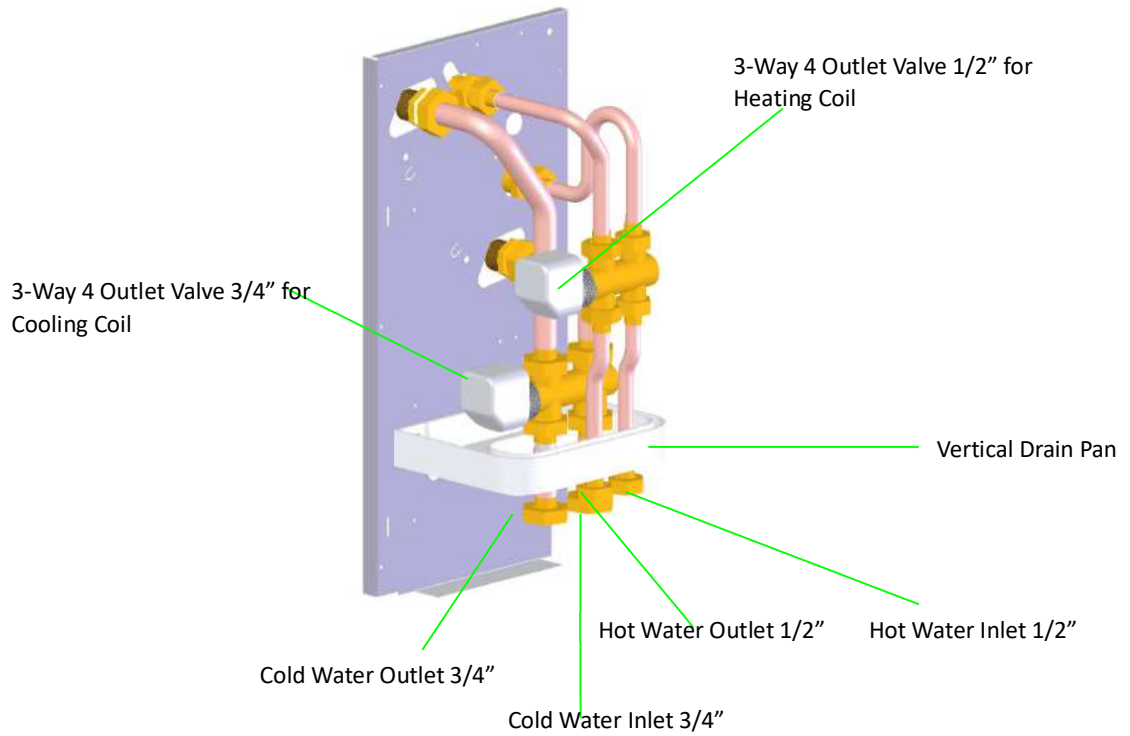

C. Maintenance

C.1. General Maintenance

1. Installation and maintenance should be performed by qualified personnel who are familiar with local codes and regulations, and are experienced with this type of appliance.
2. Confirm the unit has been switched OFF before installing or service.
3. Prevent damage and unexpected shutting down of the fan coil unit.
4. Check the cleanliness of the filter and replace or clean as required monthly.
5. Clean the coils with compressed air or water to remove dust, dirt or lint. They can be brushed with a soft brush or vacuumed with a vacuum cleaner.
6. If the water coil is not being used during the winter season, it should be drained or an anti-freezing solution should be added to the water circuit to avoid freezing.

C.2. Regular Maintenance

1. Inspect and clean the condensate drain pan to avoid any clogging of drainage by dirt, dust, etc. Inspect drainage piping to ensure the proper condensate flow.
2. Check and clean the coil. Clean the coils with a low pressure water jet or low pressure air.
3. Clean and tighten all the wiring connections.
4. Drain out the water in the system and check for build-up of mineral deposits.

C.3. Filter Installation & Cleaning

1. Insert the top edge of the filter into the top of the casing as shown below.
2. Push the bottom edge of the filter up and fit it into the casing.
3. Reverse the procedures to remove the filter.
4. Clean the filter with a brush, or with warm water.

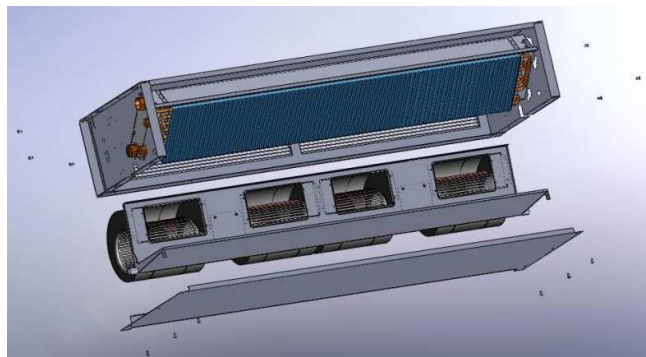
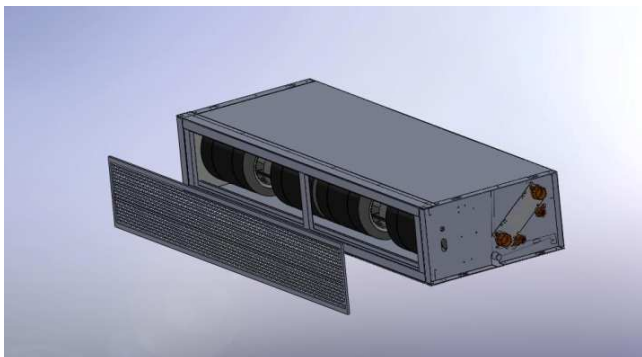

C.4. Cabinet Removal

Step 1: Open the top cover 1 and 2 as shown below.

Step 2: Loosen eight 8 screws inside.

Step 3: Remove the cabinet.

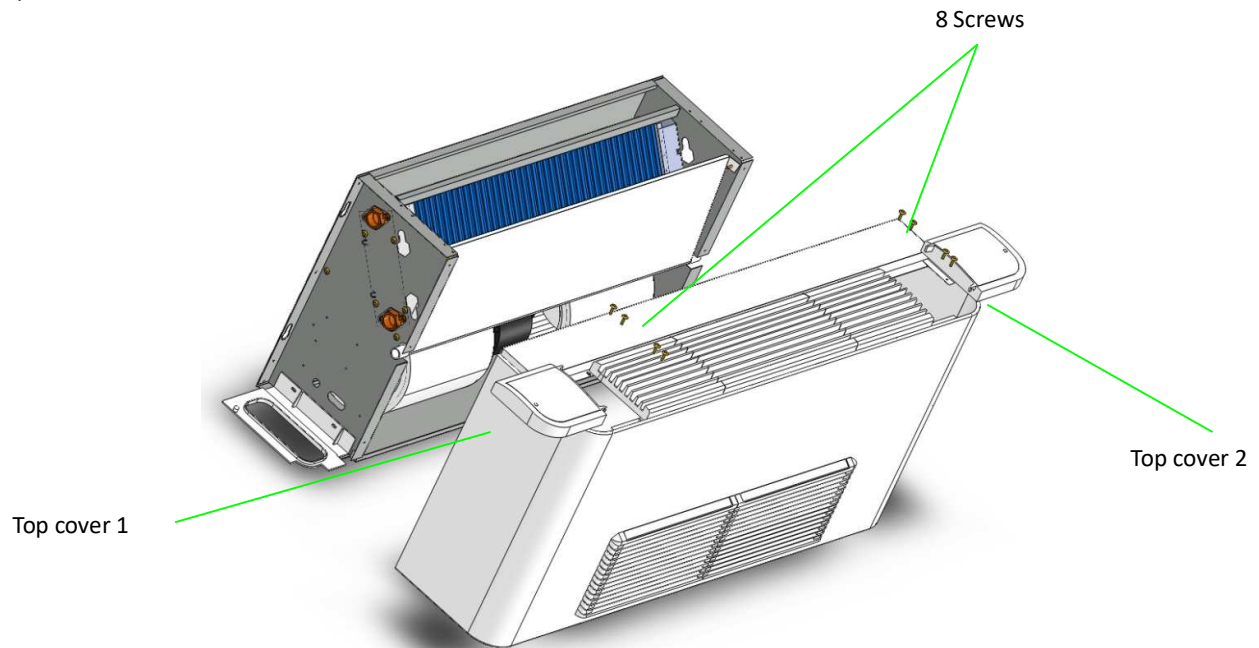

C.5. Fan Motor Assembly Maintenance

Step 1: Remove the front cabinet.

Step 2: Loosen 6 screws on both sides of the fan deck, then remove.

Step 3: Once finished with maintenance, put the fan motor assembly back into the casing and install the cabinet.

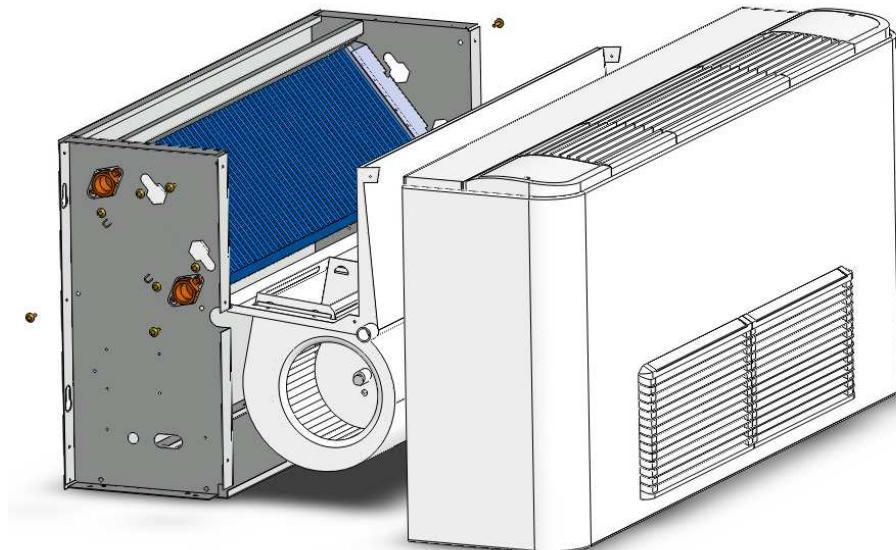

D. Control Specifications: Intelligent Control (I Type)

D.1. I/O Port Definitions

I/O		Code	Description
Analogue Input	Return air sensor	AI1	Return air temperature (Tr)
	2-pipe coil circuit sensor	AI2	Water inlet temperature sensor (Ti1)
	Hot water Sensor	AI3	Water outlet temperature sensor (Ti2)
Input	LED display / IR receiver	X-DIS 1	Digital communication port to LED display / IR receiver board.
	Wired wall pad	TTL1	Digital communication port to wired wall-pad board.
Digital input	Occupancy contact	ON/OFF	NO/NC contact by setting
	Float switch	Float	Voltage-free (NC). The contact is connected with float switch (NC);
	Electric Heater safety switch	EH	Voltage-free (NC). The contact is connected with E-heater safeties.
Power input	Phase	L1	Power supply to the PCB;
	Neutral	N1	Power supply to the PCB;
	Earth	PE1	Power supply to the PCB;
Voltage output	Fan 1	CN4	Fan 1 driver
	Fan2	CN5	Fan 2 driver
	Valve1	MTV1	On/off valve
	Valve2	MTV2	On/off valve
	Water pump	WP	Voltage output (L), Power supply to condensate pump.
	Voltage of Electric Heater (Live)	L-EH	Voltage output (L), maximum 30A.
	Stepping motor	CN1-2	Power supply to louver stepping motors.
output	Cooling signal contact.	AUX1	Voltage free contact. Maximum load 5A.
	Heating signal contact.	AUX2	Voltage free contact. Maximum load 5A.
	24VAC power input	DA1	24VAC external power supply (modulating valve applications only).
	Modulating valve control	DA2	0~10Vdc
	Modulating valve control	DA3	0~10Vdc
	In Modbus signal	AB	Modbus port
	Out Modbus signal	AB	

D.2. Wiring Diagrams

D.2.1. Standard EC-S1 Type Control PCB

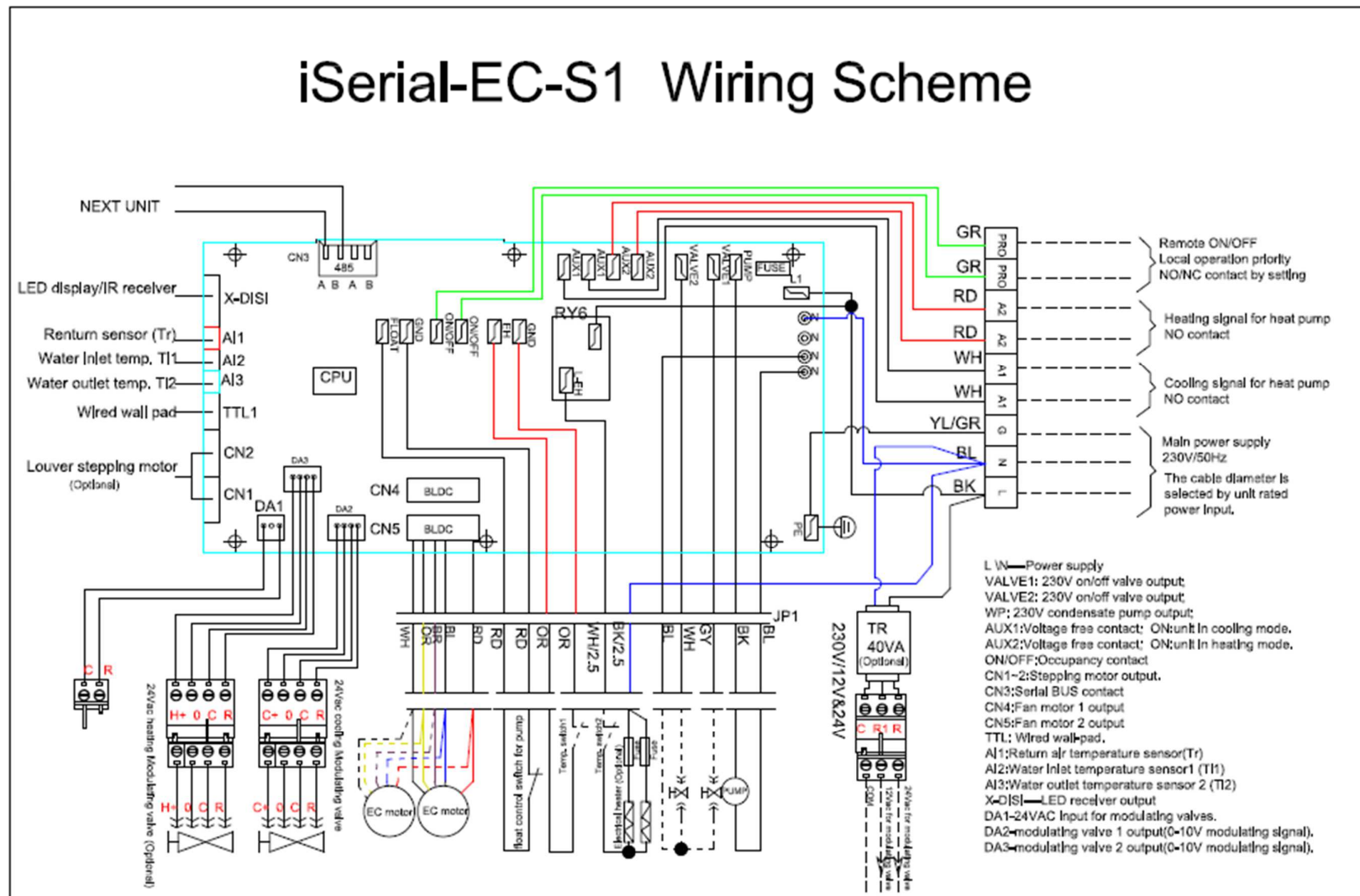

D.2.2. Fan Coil Unit ON/OFF

There are 3 ways to turn the system on or off:

- a) By the ON/OFF button on the remote handset or wired wall pad.
- b) By the programmable timer on the handset or wired wall pad.
- c) By the manual control button on fan coil unit.

D.2.3. Auto Restart

The system uses a non-volatile memory to save the present operation parameters when the system is turned off or in case of system failure or cessation of power supply.

The restored parameter data-set depends on the type of user interface.

- a) Handset only user interface:

When the power ON signal is received by the fan coil unit and no wired wall-pad is installed, the Mode, Fan Speed, Set temperature will be the same as the handset setting before the last power OFF.

- b) Wall-pad only OR wall-pad and handset user interface:

When the power ON signal is received by the fan coil unit and a wired wall-pad is installed, the Mode, Fan Speed, Set temperature and Timer ON/OFF weekly program will be the same as the wall pad setting before the last power OFF.

D.3. Control Logics for 2-Pipe System

D.3.1. With Modulating Valve Configuration

COOL MODE

When unit is turned on in cooling mode.

If $T_r \geq T_s + 1^\circ\text{C}$ (Modbus 300033 setting), MTV1 is turned on. AUX1 is closed. Fan is turned on at setting speed. DA2 is turned on at 10VDC for 2 minutes, then check Ti1:

- When $T_{i1} \leq 8^\circ\text{C}$, DA2 output is based on water temperature difference (T_{i1}/T_{i2}) and Modbus parameter 300027 setting PID calculation. The output is minimum output (Modbus300015 setting)~10VDC.
- When $8 < T_{i1} \leq 10^\circ\text{C}$, DA2 output is based on water temperature difference (T_{i1}/T_{i2}) and Modbus parameter 300027 setting minus 1 PID calculation. The output is minimum output (Modbus300015 setting)~10VDC.
- When $10 < T_{i1} \leq 12^\circ\text{C}$, DA2 output is based on water temperature difference (T_{i1}/T_{i2}) and Modbus parameter 300027 setting minus 2 PID calculation. The output is minimum output (Modbus300015 setting)~10VDC.
- When $12 < T_{i1} \leq 15^\circ\text{C}$, DA2 output is based on water temperature difference (T_{i1}/T_{i2}) and Modbus parameter 300027 setting minus 3 PID calculation. The output is minimum output (Modbus300015 setting)~10VDC.
- When $15 < T_{i1} \leq 28^\circ\text{C}$ (Modbus 300017 setting), DA2 output is kept at 10Vdc.
- When $T_{i1} > 28^\circ\text{C}$ (Modbus 300017 setting), DA2 output is at minimum (Modbus300016 setting).and report pre-heat alarm.
- If $T_r < T_s - 1^\circ\text{C}$ (Modbus 300033 setting), then cool operation is terminated and MTV1 and AUX1 are turned off. Indoor fan runs at set speed. DA2 output is 0Vdc.
- When unit is turned off, MTV1 and AUX1 are off. DA2 is 0Vdc. Fan is turned off delaying 30s.
- The range of T_s is 16 - 30°C
- Indoor fan speed can be adjusted to low, medium, high and auto.

LOW TEMPERATURE PROTECTION OF INDOOR COIL IN COOLING MODE

If $T_{i1} \leq 2^\circ\text{C}$ for 2 minutes

- MTV1 is turned OFF.
- DA2 is set to 0%.
- Indoor fan is turned on to Medium speed if fan runs at low speed.

If $T_{i1} \geq 5^\circ\text{C}$ for 2 minutes

- MTV1 is turned ON.
- DA2 is set to original status.
- Indoor fan is changed to setting speed.

FAN MODE

Indoor fan speed can be adjusted for low, medium and high. If fan speed is set auto by Modbus, fan is running at low speed.

HEAT MODE

Without Electrical Heater (Modbus300047=0)

When unit is turned on in heating mode.

When $T_r \leq T_s - 1^\circ\text{C}$ (Modbus 300033 setting), MTV1 and AUX2 is turned on. DA2 is at 10VDC for 2 minutes, then check Ti1:

- If $T_{i1} < 28^\circ\text{C}$ (Modbus 300017 setting), fan is turned on at low speed. DA2 is at 10Vdc.
- If $28^\circ\text{C} < T_{i1} < 28$ (Modbus 300017 setting) $+4^\circ\text{C}$, fan is on at original state. DA2 is at original state.
- If $T_{i1} \geq 28$ (Modbus 300017 setting) $+4^\circ\text{C}$, fan is on at setting speed. DA2 output is based on water temperature difference (T_{i1}/T_{i2}) and Modbus parameter 300028 setting PID calculation. The output is minimum output (Modbus300015 setting)~10VDC.
- If Ti1 sensor is damaged, fan runs at setting speed.
- When $T_r > T_s + 1^\circ\text{C}$ (Modbus 300033 setting), MTV1 and AUX2 is turned off. DA2 is at 0VDC. Fan is turned on at lowest speed.
- When unit is turned off, MTV1 and AUX2 is turned off. DA2 is at 00VDC. Fan is turned off delaying 2 minutes.

With Electrical Heater as booster (Modbus300047=1)

When unit is turned on in heating mode.

When $T_r \leq T_s - 1\text{ }^\circ\text{C}$ (Modbus 300033 setting), MTV1 and AUX2 is turned on. Fan is turned on at setting speed. DA2 is at 10VDC for 2 minutes, then check Ti1:

- If $T_{i1} < 28\text{ }^\circ\text{C}$ (Modbus 300017 setting), EH is turned on. DA2 is at 10Vdc.
- If $28\text{ }^\circ\text{C} < T_{i1} < 28$ (Modbus 300017 setting) $+4\text{ }^\circ\text{C}$, EH is kept at original state. DA2 is at original state.
- If $T_{i1} \geq 28$ (Modbus 300017 setting) $+4\text{ }^\circ\text{C}$, EH is turned off. DA2 output is based on water temperature difference (T_{i1}/T_{i2}) and Modbus parameter 300028 setting PID calculation. The output is minimum output (Modbus300015 setting) $\sim 10\text{VDC}$.
- If Ti1 sensor is damaged, fan runs at setting speed.
- When $T_r > T_s + 1\text{ }^\circ\text{C}$ (Modbus 300033 setting), MTV1 and AUX2 is turned off. EH is turned off. DA2 is at 0VDC. fan is turned on at low speed.
- When unit is turned off, MTV1 and AUX2 is turned off. DA2 is at 0 VDC. Fan is turned off delaying 2 minutes.

With Electrical Heater as booster (Modbus300047=2)

When unit is turned on in heating mode.

- When $T_{i2} \leq 35\text{ }^\circ\text{C}$ (or T_{i2} is broken) and $T_r \leq T_s - 1\text{ }^\circ\text{C}$ (Modbus 300033 setting). Fan is turned on at setting speed, EH is turned on.
- When $T_r > T_s\text{ }^\circ\text{C}$, EH is turned off. fan is turned on at low speed.
- When unit is turned off, EH is turned off. Fan is turned off delaying 2 minutes.

OVER-HEAT PROTECTION OF INDOOR COIL

- If $T_{i1} \geq 75\text{ }^\circ\text{C}$, then MTV1 ,AUX2, DA2 and EH are turned off. Indoor fan remains on and runs at high speed.
- If $T_{i1} < 70\text{ }^\circ\text{C}$, then unit keep original state.
- If the indoor coil temperature sensor is damaged or not connected, then the protection mode will be overridden and the unit will work according to the pre-heat and post-heat program.

DEHUMIDIFICATION MODE

When unit is turned on in dehumidification mode:

- AUX1 is turned on. T_s is $24\text{ }^\circ\text{C}$.
- If $T_r \geq 25\text{ }^\circ\text{C}$ for 30S, then MTV1 will be ON for 3 minutes, and then OFF for 4 minutes. DA2 is on at 3 times of (Modbus 300016 setting). Fan is turned on at low speed.
- If $16\text{ }^\circ\text{C} \leq T_r < 25\text{ }^\circ\text{C}$ for 30S, then MTV1 will be ON for 3 minutes, and then OFF for 6 minutes. DA2 is on at double of (Modbus 300016 setting). Fan is turned on at low speed.
- If $T_r < 16\text{ }^\circ\text{C}$ for 30S, then MTV1 will be ON for 3 minutes, and then OFF for 10 minutes. DA2 is on at (Modbus 300016 setting). Fan is turned on at low speed.
- At the end of the above dehumidification cycle, the system will decide the next dehumidification control option.

AUTO MODE

When unit is turned on in Auto mode, fan is turned on at setting speed for 30S, then check T_r and T_s .

- If $T_s \geq T_r + 3\text{ }^\circ\text{C}$, the unit runs in heating mode.
- If $T_r - 3\text{ }^\circ\text{C} < T_s < T_r + 3\text{ }^\circ\text{C}$, the unit runs in fan mode.
- If $T_s < T_r - 3\text{ }^\circ\text{C}$, the unit runs in cooling mode.
- If unit working mode is confirmed, the unit will not change the working mode. After the unit is turned off and restart it in 2 hours, working mode will be confirmed again.

PRO INPUT FUNCTION

When 100004=0.

The unit is on:

- PRO input is closed for 60S, the unit is turned off.
- PRO input is open for 60S, the unit is turned on.

When 100004=1.

The unit is on or standby, PRO input is open or closed, the unit is kept original state.

The unit is off:

- PRO input is closed for 30S, MTV1 is turned on, DA2 is open at double of minimum setting (Modbus 300027 setting), and Fan is turn on at low speed.
- PRO input is opened for 30S, MTV1 is off, DA2 is 0Vdv, Fan is turn off.
- In period of PRO closed time, if unit receives instruction from remote handset, wired wall pad or Modbus, the unit will work according to the instruction at once.

D.4. Control Logics for 4-Pipe System

Note: 4-pipe system must always be equipped with 2 valves.

COOL MODE

When unit is turned on in cooling mode.

If $Tr \geq Ts + 1^{\circ}C$ (Modbus 300033 setting), MTV1 is turned on. AUX1 is closed. Fan is turned on at setting speed. DA2 is turned on at 10VDC for 2 minutes, then check Tr and Ts.

- DA2 output is from minimum (Modbus 300016 setting) $\sim 10Vdc$ based on Tr and $(Ts + 2)$ PID calculation.
- If $Tr < Ts - 1^{\circ}C$ (Modbus 300033 setting), then cool operation is terminated and MTV1 and AUX1 are turned off. Indoor fan runs at set speed. DA2 output is 0Vdc.
- When unit is turned off, MTV1 and AUX1 are off. DA2 is 0Vdc. Fan is turned off delaying 30s.
- The range of Ts is 16 - 30 $^{\circ}C$
- Indoor fan speed can be adjusted to low, medium, high and auto.

LOW TEMPERATURE PROTECTION OF INDOOR COIL IN COOLING MODE

If $Ti1 \leq 2^{\circ}C$ for 2 minutes

- MTV1 is turned OFF,
- DA2 is set to 0%,
- Indoor fan is turned on to Medium speed if fan runs at low speed.

If $Ti1 \geq 5^{\circ}C$ for 2 minutes

- MTV1 is turned ON,
- DA2 is set to original status,
- Indoor fan is changed to setting speed

FAN MODE

Indoor fan speed can be adjusted for low, medium and high. If fan speed is set auto by Modbus, fan is running at low speed.

HEAT MODE

Without Electrical Heater (Modbus300047=0)

When unit is turned on in heating mode.

When $Tr \leq Ts - 1^{\circ}C$ (Modbus 300033 setting), MTV2 and AUX2 is turned on. DA3 is at 10VDC for 2 minutes, then check Ti2:

- If $Ti2 < 28^{\circ}C$ (Modbus 300017 setting), fan is turned on at low speed. DA3 is at 10Vdc.
- If $28^{\circ}C < Ti2 < 28$ (Modbus 300017 setting) $+4^{\circ}C$, fan is on at original state. DA3 is at original state.
- If $Ti2 \geq 28$ (Modbus 300017 setting) $+4^{\circ}C$, fan is on at setting speed. DA3 output is from minimum (Modbus 300016 setting) $\sim 10Vdc$ based on Tr and $(Ts - 2)$ PID calculation.
- If Ti2 sensor is damaged, fan runs at setting speed.
- When $Tr > Ts + 1^{\circ}C$ (Modbus 300033 setting), MTV2 and AUX2 is turned off. DA3 is at 0VDC. fan is turned on at lowest speed.
- When unit is turned off, MTV2 and AUX2 is turned off. DA3 is at 0 VDC. Fan is turned off delaying 2 minutes.

With Electrical Heater as booster (Modbus300047=1)

When unit is turned on in heating mode.

When $Tr \leq Ts - 1^{\circ}C$ (Modbus 300033 setting), MTV2 and AUX2 is turned on. Fan is turned on at setting speed. DA3 is at 10VDC for 2 minutes, then check Ti2:

- If $Ti2 < 28^{\circ}C$ (Modbus 300017 setting), EH is turned on. DA3 is at 10Vdc.
- If $28^{\circ}C < Ti2 < 28$ (Modbus 300017 setting) $+4^{\circ}C$, EH is kept at original state. DA3 is at original state.

- If $Ti2 \geq 28$ (Modbus 3000017 setting) $+4^{\circ}\text{C}$, EH is turned off. DA3 output is from minimum (Modbus 300016 setting) $\sim 10\text{Vdc}$ based on T_r and $(T_s - 2)$ PID calculation.
- If $Ti2$ sensor is damaged, fan runs at setting speed.
- When $T_r > T_s + 1^{\circ}\text{C}$ (Modbus 300033 setting), MTV2 and AUX2 is turned off. EH is turned off. DA3 is at 0Vdc. fan is turned on at low speed.
- When unit is turned off, MTV2 and AUX2 is turned off. DA3 is at 0Vdc. Fan is turned off delaying 2 minutes.

OVER-HEAT PROTECTION OF INDOOR COIL

- If $Ti2 \geq 75^{\circ}\text{C}$, then MTV2, AUX2, DA2 and EH are turned off. Indoor fan remains on and runs at high speed.
- If $Ti2 < 70^{\circ}\text{C}$, then unit keep original state.
- If the indoor coil temperature sensor is damaged or not connected, then the protection mode will be overridden and the unit will work according to the pre-heat and post-heat program.

DEHUMIDIFICATION MODE

When unit is turned on in dehumidification mode:

- AUX1 is turned on. T_s is 24°C .
- If $T_r \geq 25^{\circ}\text{C}$ for 30S, then MTV1 will be ON for 3 minutes, and then OFF for 4 minutes. DA2 is on at 3 times of (Modbus 300016 setting). Fan is turned on at low speed.
- If $16^{\circ}\text{C} \leq T_r < 25^{\circ}\text{C}$ for 30S, then MTV1 will be ON for 3 minutes, and then OFF for 6 minutes. DA2 is on at double of (Modbus 300016 setting). Fan is turned on at low speed.
- If $T_r < 16^{\circ}\text{C}$ for 30S, then MTV1 will be ON for 3 minutes, and then OFF for 10 minutes. DA2 is on at (Modbus 300016 setting). Fan is turned on at low speed.
- At the end of the above dehumidification cycle, the system will decide the next dehumidification control option.

AUTO MODE

- When unit is turned on in Auto mode, fan is turned on at setting speed for 30S, then check T_r and T_s .
- If $T_s \geq T_r + 3^{\circ}\text{C}$, the unit runs in heating mode.
- If $T_r - 3^{\circ}\text{C} < T_s < T_r + 3^{\circ}\text{C}$, the unit runs in fan mode.
- If $T_s < T_r - 3^{\circ}\text{C}$, the unit runs in cooling mode.
- If unit works in heating or fan mode, when $T_r - T_s > 3.0^{\circ}\text{C}$, MTV2, MTV1 and DA2 is off for more than 10minutes. EH is off for more than 10 minutes, the unit will work in cooling mode.
- If unit works in cooling or fan mode, when $T_s - T_r > 3.0^{\circ}\text{C}$, MTV2, MTV1 and DA1 is off for more than 10minutes. The unit will work in heating mode.

PRO INPUT FUNCTION

When the unit is on:

- PRO input is closed for 60S, the unit is turned off.
- PRO input is open for 60S, the unit is turned on.

D.5. Control Logics for 2-pipe with 6-way modulating valve

COOL MODE

When unit is turned on in cooling mode.

If $T_r \geq T_s + 1^\circ\text{C}$ (Modbus 300033 setting), MTV1 is turned on. AUX1 is closed. Fan is turned on at setting speed.

DA2 is turned on at 0VDC for 2 minutes, then check Ti1:

- When $T_{i1} \leq 8^\circ\text{C}$, DA2 output is based on water temperature difference (T_{i1}/T_{i2}) and Modbus parameter 300027 setting PID calculation. The output is 4~0VDC.
- When $8 < T_{i1} \leq 10^\circ\text{C}$, DA2 output is based on water temperature difference (T_{i1}/T_{i2}) and Modbus parameter 300027 setting minus 1 PID calculation. The output is 4~0VDC.
- When $10 < T_{i1} \leq 12^\circ\text{C}$, DA2 output is based on water temperature difference (T_{i1}/T_{i2}) and Modbus parameter 300027 setting minus 2 PID calculation. The output is 4~0VDC.
- When $12 < T_{i1} \leq 15^\circ\text{C}$, DA2 output is based on water temperature difference (T_{i1}/T_{i2}) and Modbus parameter 300027 setting minus 3 PID calculation. The output is 4~0VDC.
- When $15 < T_{i1} \leq 28^\circ\text{C}$ (Modbus 300017 setting), DA2 output is kept at 0Vdc.
- When $T_{i1} > 28^\circ\text{C}$ (Modbus 300017 setting), DA2 output is 4Vdc. and report pre-heat alarm.
- If $T_r < T_s - 1^\circ\text{C}$ (Modbus 300033 setting), then cool operation is terminated and MTV1 and AUX1 are turned off. Indoor fan runs at set speed. DA2 output is 5Vdc.
- When unit is turned off, MTV1 and AUX1 are off. DA2 is 5Vdc. Fan is turned off delaying 30s.
- The range of T_s is 16 - 30°C
- Indoor fan speed can be adjusted to low, medium, high and auto.

LOW TEMPERATURE PROTECTION OF INDOOR COIL IN COOLING MODE

If $T_{i1} \leq 2^\circ\text{C}$ for 2 minutes

- MTV1 is turned OFF,
- DA2 is set to 5Vdv,
- Indoor fan is turned on to Medium speed if fan runs at low speed.

If $T_{i1} \geq 5^\circ\text{C}$ for 2 minutes

- MTV1 is turned ON,
- DA2 is set to original status,
- Indoor fan is changed to setting speed

FAN MODE

Indoor fan speed can be adjusted for low, medium and high. If fan speed is set auto by Modbus, fan is running at low speed.

HEAT MODE

Without Electrical Heater (Modbus300047=0)

When unit is turned on in heating mode.

When $T_r \leq T_s - 1\text{ }^\circ\text{C}$ (Modbus 300033 setting), MTV2 and AUX2 is turned on. DA2 is at 10VDC for 2 minutes, then check Ti1:

- If $T_{i1} < 28\text{ }^\circ\text{C}$ (Modbus 300017 setting), fan is turned on at low speed. DA2 is at 10Vdc.
- If $28\text{ }^\circ\text{C} < T_{i1} < 28$ (Modbus 300017 setting) $+4\text{ }^\circ\text{C}$, fan is on at original state. DA2 is at original state.
- If $T_{i1} \geq 28$ (Modbus 300017 setting) $+4\text{ }^\circ\text{C}$, fan is on at setting speed. DA2 output is based on water temperature difference (T_{i1}/T_{i2}) and Modbus parameter 300028 setting PID calculation. The output is 6~10VDC.
- If Ti1 sensor is damaged, fan runs at setting speed.
- When $T_r > T_s + 1\text{ }^\circ\text{C}$ (Modbus 300033 setting), MTV1 and AUX2 is turned off. DA3 is at 5VDC. fan is turned on at lowest speed.
- When unit is turned off, MTV1 and AUX2 is turned off. DA2 is at 5VDC. Fan is turned off delaying 2 minutes.

With Electrical Heater as booster (Modbus300047=1)

When unit is turned on in heating mode.

When $T_r \leq T_s - 1\text{ }^\circ\text{C}$ (Modbus 300033 setting), MTV2 and AUX2 is turned on. Fan is turned on at setting speed. DA2 is at 10VDC for 2 minutes, then check Ti1:

- If $T_{i1} < 28\text{ }^\circ\text{C}$ (Modbus 300017 setting), EH is turned on. DA2 is at 10Vdc.
- If $28\text{ }^\circ\text{C} < T_{i1} < 28$ (Modbus 300017 setting) $+4\text{ }^\circ\text{C}$, EH is kept at original state. DA2 is at original state.
- If $T_{i1} \geq 28$ (Modbus 300017 setting) $+4\text{ }^\circ\text{C}$, EH is turned off. DA2 output is based on water temperature difference (T_{i1}/T_{i2}) and Modbus parameter 300028 setting PID calculation. The output is 6~10VDC.
- If Ti1 sensor is damaged, fan runs at setting speed.
- When $T_r > T_s + 1\text{ }^\circ\text{C}$, MTV2 and AUX2 is turned off. EH is turned off. DA2 is at 5VDC. fan is turned on at low speed.
- When unit is turned off, MTV2 and AUX2 is turned off. DA2 is at 5VDC. Fan is turned off delaying 2 minutes.

OVER-HEAT PROTECTION OF INDOOR COIL

- If $T_{i1} \geq 75\text{ }^\circ\text{C}$, then MTV1, AUX2, DA2 and EH are turned off. Indoor fan remains on and runs at high speed.
- If $T_{i1} < 70\text{ }^\circ\text{C}$, then unit keep original state.
- If the indoor coil temperature sensor is damaged or not connected, then the protection mode will be overridden and the unit will work according to the pre-heat and post-heat program.

DEHUMIDIFICATION MODE

When unit is turned on in dehumidification mode:

- AUX1 is turned on. T_s is 24 $^\circ\text{C}$.
- If $T_r \geq 25\text{ }^\circ\text{C}$ for 30S, then MTV1 will be ON for 3 minutes, and then OFF for 4 minutes. DA2 is 2vdc. Fan is turned on at low speed.
- If $16\text{ }^\circ\text{C} \leq T_r < 25\text{ }^\circ\text{C}$ for 30S, then MTV1 will be ON for 3 minutes, and then OFF for 6 minutes. DA2 is 2.5VDC. Fan is turned on at low speed.
- If $T_r < 16\text{ }^\circ\text{C}$ for 30S, then MTV1 will be ON for 3 minutes, and then OFF for 10 minutes. DA2 is 3.5VDC.
- At the end of the above dehumidification cycle, the system will decide the next dehumidification control option.

AUTO MODE

When unit is turned on in Auto mode, fan is turned on at setting speed for 30S, then check T_r and T_s :

- If $T_s \geq T_r + 3\text{ }^\circ\text{C}$, the unit runs in heating mode.
- If $T_r - 3\text{ }^\circ\text{C} < T_s < T_r + 3\text{ }^\circ\text{C}$, the unit runs in fan mode.
- If $T_s < T_r - 3\text{ }^\circ\text{C}$, the unit runs in cooling mode.
- If unit works in heating or fan mode, when $T_r - T_s > 3.0\text{ }^\circ\text{C}$, MTV2, MTV1 and DA2 is off for more than 10minutes. EH is off for more than 10 minutes, the unit will work in cooling mode.
- If unit works in cooling or fan mode, when $T_s - T_r > 3.0\text{ }^\circ\text{C}$, MTV2, MTV1 and DA2 is off for more than 10minutes. The unit will work in heating mode.

PRO INPUT FUNCTION

When the unit is on:

- PRO input is closed for 60S, the unit is turned off.
- PRO input is open for 60S, the unit is turned on.

D.6. Sleep Mode

- SLEEP mode can only be set when the unit is in COOL or HEAT mode.
- In COOL mode, after SLEEP mode is set, the indoor fan will run at auto speed and Ts will increase by 0.5°C each 30 minutes. Maximum setting temperature increased is 3°C.
- In HEAT mode, after SLEEP mode is set, the indoor fan will run at auto speed and Ts will decrease by 0.5 °C each 30 minutes.
- Sleep mode is turned off, Setting temperature go back and fan is changed to setting speed.

D.7. Buzzer

The unit will beep once when it receives a signal.

D.8. Auto Restart

The system uses non-volatile memory to save the present operation parameters when system is turned off or in case of system failure or cessation of power supply. Operation parameters are mode, set temperature, louver's position, and the fan speed. When power supply resumes or the system is switched on again, the same operations as previously set will function.

D.9. On/Off Switch On LED Display Panel

- This is a TACT switch to select Cool→Heat→Off operation mode.
- In COOL mode, the set temperature of the system is 24°C with auto fan speed. There are no timer and sleep modes.
- In HEAT mode, the set temperature of the system is 24°C with auto fan speed. There are no timer and sleep modes.
- Master unit that does not use a wall pad will globally broadcast.

NOTE

When button pressing is effective, the master unit buzzer will beep twice and the slave unit will beep once.

D.10. Drain pump

Drain pump turns ON if the unit is turned on in cooling or dehumidification mode. It remains on for at least 5 minutes after unit is turned OFF. During mode change from cooling or dehumidification to heating or fan mode, the water pump will turn on for a minimum of 5 minutes.

CAUTION

If the system is turned off at the circuit breaker (or main power supply), the drain pump will not work.

D.11. Float Switch

Float-switch opens before unit is turned on

- If the float switch (N/C) is opened before the unit is turned on, then MTV1 is turned off. The drain pump and indoor fan will operate.
- After float switch is closed, MTV1 is turned on.

Float switch is opened, when unit is turned on

- If the float switch is opened continuously ≥ 5 seconds, then the drain pump will work and MTV1 will remain off.
- After the float switch is closed, the drain pump will run for an additional 5 minutes.

- If the float switch is opened for 10 minutes continuously, then MTV1 will remain off. The indoor fan runs at set speed and the system reports an error.

Float switch is opened, when unit is turned off

- If the float switch is opened, then the drain pump will work.
- After the float switch is closed, the drain pump will run for an additional 5 minutes. If the float switch is opened for 10 minutes continuously, then the system reports an error.

D.12. Electric Heater Safety Switch

- Before the electrical heater is turned on, the EH safety switch must be closed and EC motor RPM must be more than Modbus 300020 setting.
- When electrical heater is ON, electrical heater safety switch is opened for ≥ 1 second or EC motor RPM is lower than Modbus 300020 setting, EH will be turned off immediately and report an error and fan speed is changed to high speed.
- Once the contact is returned to the closed ≥ 180 seconds, EC motor RPM must be more than MODBUS300020 setting, reset the error and the heater will start again.
- When the EH safety switch is opened ≥ 3 times within 60 minutes the heater is not allowed to start anymore.
- Turn off the unit to reset the fault, provided that the switch has returned to the closed position.

D.13. Low Temperature Protection of Indoor Coil in Winter

This is frost protection for when the unit is off to prevent water in the coil and room from freezing.

If 2pipe unit is in Standby Mode

If $Tr \leq 2$ °C for 2 minutes

- MTV1 is turned ON,
- AUX2 is closed,
- DA2 is 5VDC.
- If $Ti1 < 5$ °C for 2 minutes EH (if present) is switched on
- Indoor fan is turned on at low speed.

If $Tr \geq 5$ °C for 2 minutes

- MTV2 is OFF,
- AUX2 is open,
- DA2 is set to 0 VDC.
- Electric Heater is turned off.
- Indoor fan is switched off.

If 4-pipe unit is in Standby Mode

If $Tr \leq 2$ °C for 2 minutes

- MTV2 is turned ON.
- AUX2 is closed.
- DA3 is 5VDC. if unit with 6-way valve, DA2 is 8 VDC.
- If $Ti1 < 5$ °C for 2 minutes EH (if present) is switched on
- Indoor fan is turned on at low speed.

If $Tr \geq 5$ °C for 2 minutes

- MTV2 is off.
- AUX2 is open.
- DA3 is set to 0. If unit with 6-way valve, DA2 is 5VDC.
- Electric Heater is turned off.
- Indoor fan is switched off.

D.14. Network Setup

- a) Disconnect the communication plug from the control box

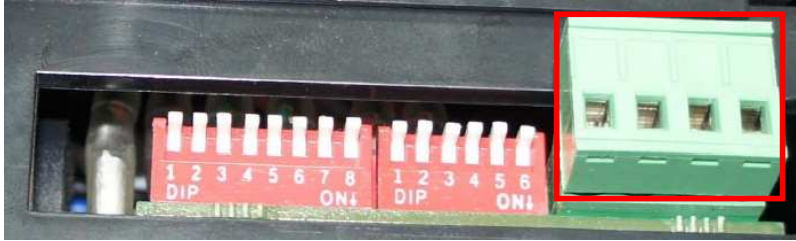

- b) Communication plug

A, B, A, B is printed on the main PCB. When you connect the wires, please ensure connection of A to A and B to B.



- c) Connection wire

- i. If the total length of wire is more than 1000m, please use shielded wire in order to protect the signal transmission.
- ii. Complete wire connection

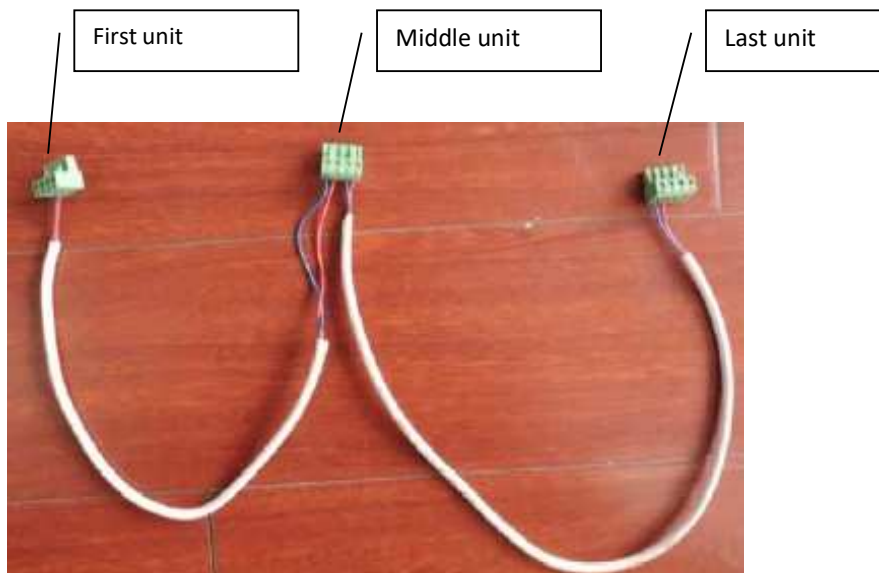

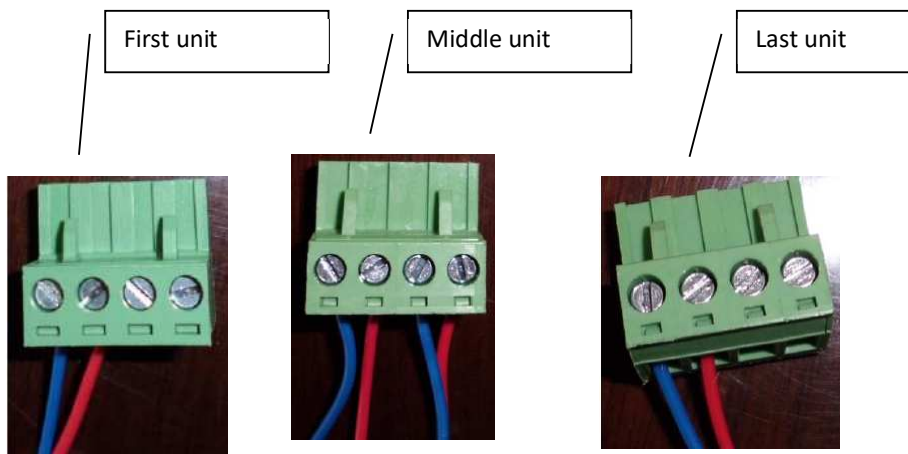

iii. Wire connection check

- 1) After the wire connection is completed, please check the wire colours correspond.
- 2) Check the wire contact by using a multimeter.

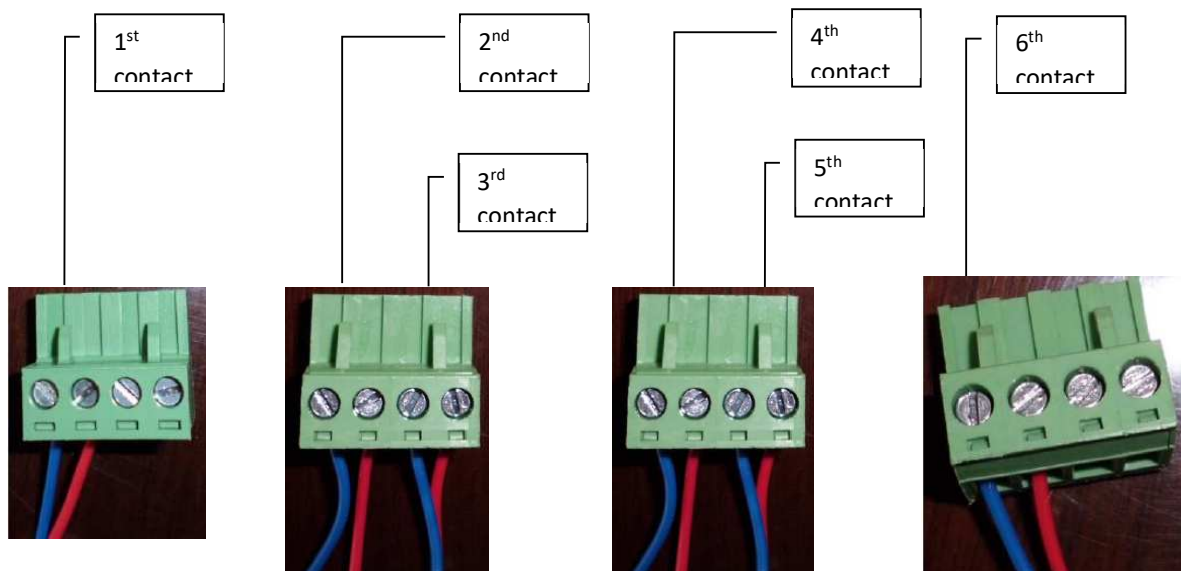

- 3) Check 1 and 2, 3 and 4, 5 and 6 to be sure the connections are correct.
- 4) If the resistance between two wire contacts is too high, please check and reconnect the wire contacts.

- d) Reconnect the communication plug to the control box

D.15. Open Modbus Protocol

Transfer Mode: RTU BAUD Rate: 9600 bps, 8 data bit, 1 stop bit, None parity bit

The communications require a delay between reading an answer and sending the next command of 80 Ms. All temperature is equal to reading data*10 accuracy: 0.1 degree C.

Supported Functions

Function Code	Function description
01(01H)	Read Coils
02(02H)	Read Discrete Inputs
03(03H)	Read Holding Registers
04(04H)	Read Input Registers
05(05H)	Write Single Coil
06(06H)	Write Single Register
15(0FH)	Write Multiple Coils
16(10H)	Write Multiple Registers
255(FFH)	Extended Commands which are used to test.

Valid Error code table:

Error code	description	definition
01 (01H)	Invalid commands	Received commands beyond valid commands
02 (02H)	Invalid data address	Data addresses beyond valid data address
03 (03H)	Invalid data	Data beyond definition range
04 (04H)	Write data not succeed	Write data not succeed

Coils table:

Description	Address	Type*	Remark
ON/OFF	100000	R/W	
Sleeping mode	100001	R/W	
Louver swings	100002	R/W	
Energy Saving Mode	100003	R/W	
PRO function	100004	R/W	

Discrete table:

Description	Address	Type*	Remark
MTV1	200000	R	
MTV2	200001	R	
AUX1	200002	R	
AUX2	200003	R	
Condensate pump	200004	R	
Electrical heater	200005	R	
Wired wall pad	200006	R	
PR-O1	200007	R	
Float switch	200008	R	
Reserved	200009	R	
EH safety switch	200010	R	
Internal test	200011	R	Testing purpose only.

* R = read only, W = write only, R/W = read and write.

Holding Register table:

Description	Address	Type*	Remark
Mode setting	300000	R/W	Cooling mode = 01(H) Humidify mode = 02(H) Fan mode = 04(H) Heating mode = 08(H) Auto mode = 10(H)
Fan speed setting	300001	R/W	Low speed = 04(H) Medium speed = 02(H)

			High speed = 01(H) Auto fan speed = 07(H)
Louver swing setting	300002	R/W	Position 1=01(H)
			Position2=02(H)
			Position3=03(H)
			Position4=04(H)
			Auto=0F(H)
			Stop=00(H)
Setting temperature	300003	R/W	16~30 (actual*10 format)
Address setting	300004	R/W	1~255
Reset	300005	W	=0x33 reset error
Week	300006	W	
Hour	300007	W	
Minute	300008	W	
Second	300009	W	
Hours in Timer on	300010	R/W	Timer ON
Minute in Timer on	300011	R/W	Timer ON
Hours in Timer off	300012	R/W	Timer OFF
Minute in Timer off	300013	R/W	Timer OFF
Icon of Timer ON or OFF	300014	R/W	BIT0 = Icon of Timer ON BIT1 = Icon of Timer OFF 1 = enable 0 = disable
Minimum output DA1	300015	R/W	Default 25% (2.5vdc)
Minimum output DA2	300016	R/W	Default 25% (2.5vdc)
Pre-heat temperature setting	300017	R/W	25~35, default: 30
Reserved-	300018	R/W	
Super low speed rpm	300019	R/W	
Low speed rpm	300020	R/W	
Medium speed rpm	300021	R/W	
High speed rpm	300022	R/W	
Signal output setting	300023	R/W	1~10VDC (used to test , 0 = disable)
Temperature sampling time	300024	R/W	2~100 , default: 5S
Factor of auto fan speed	300025	R/W	2~150 , default:20
Factor of modulating valve	300026	R/W	2~250 , default:150
Ti1 and Ti2 Cooling difference setting	300027	R/W	3~15 , default:5
Ti1 and Ti2 Heating difference setting	300028	R/W	3~15 default:5
Controller Hardware type setting	300029	R/W	0=air cleaner (S5) 1=FCU (S1/S2/S3, SWC-S) 2=AHU (S6) or (AHU+W5) 3=AHU+AQL (S5+S6) 4=Zone controller(S7) Setting : 1
Degree unit setting	300030	R/W	0=degree C 1=degree F
Temperature display setting	300031	R/W	0=Room temperature display on LED 1=Setting temperature display on LED
Setting temperature range	300032	R/W	0=setting temperature range is from 16~30 1=Setting temperature range is fixed. Cooling=24oC Heating=21oC
Temperature band setting	300033	R/W	
Reserved	300034	R/W	
Reserved	300035	R/W	
Reserved	300036	R/W	
Reserved	300037	R/W	

Reserved	300038	R/W	
Reserved	300039	R/W	
Reserved	300040	R/W	
Reserved	300041	R/W	
Reserved	300042	R/W	
Reserved	300043	W	
Reserved	300044	W	
Reserved	300045	W	
Software type	300046	R/W	0=2-pipe+MTV. 1=2-pipe without valve 2=4-pipe+std valve 3=4-pipe+6-way valve
EH type	300047	R/W	0=without EH, 1=EH as booster; 2=EH as primary
DA1 control signal	300048	R/W	0=Tr/Ts 1=ESP
EC motor input ports	300049	R/W	0=CN4 working ; 1=CN5 working 2=CN4+CN5 working default : 0
PRO1 input type	300050	R/W	0=NO ; 1=NC
Tr sensor setting	300051	R/W	0=sensor on the wired wall pad ; 1=sensor on the main PCB ; default : 0
Reserved	300052	R/W	0~120 , default : 80
Optimized swing angle	300053	R/W	200~999 default : 0 ;
E-heater	300054	R/W	Unit : KW*10
Room temp. factor	300055	R/W	90~120 , default : 103
Water inlet temp. factor	300056	R/W	90~120 , default : 103
Delt T factor	300057	R/W	90~120 , default : 102
Product type	300058	R/W	00~99; default : 00
Product model	300059	R/W	000~999; default : 000
Ex-works data	300060	R/W	0000—9999
Software version	300061	R	10~99 default : 10
Hardware version	300062	R	10~99 default : 10
Reserved	300063	R/W	
Reserved	300064	R/W	
Reserved	300065	R/W	
Reserved	300066	R/W	
Reserved	300067	R/W	
In auto mode, temp. Band setting	300068	R/W	1~15 , default:3
Reserved	300069	R/W	
Reserved	300070	R/W	
Unit power input at High speed	300071	R/W	W*10
Unit power input at Med. speed	300072	R/W	W*10
Unit power input at Low speed	300073	R/W	W*10
Unit heat capacity at High speed	300074	R/W	KW*10
Unit heat capacity at Med. speed	300075	R/W	KW*10
Unit heat capacity at Low speed	300076	R/W	KW*10
Unit cool capacity at High speed	300077	R/W	KW*10
Unit cool capacity at Med. speed	300078	R/W	KW*10
Unit cool capacity at Low speed	300079	R/W	KW*10

* R = read only, W = write only, R/W = read and write.

Input Register table:

Description	Address	Type*	Remark
Tr temperature sensor	400000	R	
Ti1 temperature sensor	400001	R	
Ti2 temperature sensor	400002	R	
Reserved	400003	R	
Reserved	400004	R	
Error code	400005	R	Bit0 = Room temperature sensor error Bit1 = Ti1 temperature sensor error

			Bit2 = Ti2 temperature sensor error Bit3 = Float switch error Bit4 = Indoor coil low temperature protection Bit5 = Indoor coil overheat protection Bit6 = Filter switch Bit7 = Electrical heater failure Bit8 = Motor1 Error Bit9 = Motor2 Error Bit10 = System parameters error Bit11 = Anti-frozen error Bit12 = Ti3 temperature sensor error Bit13 = Ti4 temperature sensor error Bit14 = PM2.5 sensor Bit15 = AQI Error
Fan speed status	400006	R	Low = 04(H) Medium = 02(H) High = 01(H)
Reserved	400007	R	
Reserved	400008	R	
EH	400009	R	0= disable, 1=booster, 2=primary
Unit type	400010	R	
DA1	400011	R	
DA2	400012	R	
Reserved	400013	R	
Reserved	400014	R	
Reserved	400015	R	
Reserved	400016	R	
Unit status	400017	R	Cooling mode = 01(H) Humidify mode = 02(H) Fan mode = 04(H) Heating mode = 08(H) Unit OFF=32(H)
Temperature in wall pad	400018	R	
Motor running time	400019	R	
Motor running terms	400020	R	0~100
Cooling capacity	400021	R	
Cooling capacity terms	400022	R	0~100
Heating capacity	400023	R	
Heat capacity terms	400024	R	0~100
Reserved	400025	R	
Reserved	400026~35	R	
EC motor1 actual RPM	400036	R	
EC motor2 actual RPM	400037	R	
EC motor1 error	400038	R	
EC motor2 error	400039	R	

D.16. LED Display and Error Description

LED receiver in ABS housing with 0.5m or 1.8m pre-wiring



Complete Function PCB – I Type Control		
Fan speed setting	LED display	Condition
High speed	Red LED On	Normal
Medium speed	Yellow LED On	Normal
Low speed	Green LED On	Normal

For all units - Green LED			
Error Description	Blink	Reason	Remedy
Return air sensor failure	Green LED blinks 1 times, stops for 3s	Room sensor unplugged or damaged.	1. Check if Tr plug is connected or not. 2. Check if sensor's resistance is correct or not.
Indoor coil sensor 1 failure	Green LED blinks 2 times, stops for 3s	Ti1 sensor unplugged or damaged.	1. Check if Ti1 plug is connected or not. 2. Check if sensor's resistance is correct or not.
Indoor coil sensor 2 failure	Green LED blinks 3 times, stops for 3s	Ti2 sensor unplugged or damaged.	1. Check if Ti2 plug is connected or not. 2. Check if sensor's resistance is correct or not.
Water pump failure	Green LED blinks 4 times, stops for 3s	Float switch is opened.	1. Check if the condensate water pipe is connected or not. 2. Check if the pump is functioning or not.
Indoor coil low temperature protection	Green LED blinks 5 times, stops for 3s	Water temperature is lower than 3 °C.	Check the water temperature.
Indoor coil overheat protection	Green LED blinks 6 times, stops for 3s	Water temperature is higher than 70 °C.	Check the water temperature
Filter Switch (S6 PCB)	Green LED blinks 7 times, stops for 3s	Filter switch is opened.	1. Check if filter block or not 2. replace the new filter
Electric Heater failure	Green LED blinks 8 times, stops for 3s	Only for unit with EH. EH safety switch is opened.	1. Change fan speed to high. 2. Replace the damaged EH safety switch.
EC motor failure(CN4)	Green LED blinks 9 times, stops 3s	No EC motor feedback	1. Check Modbus setting. 2. Check the EC motor.
EC motor failure(CN5)	Green LED blinks 10 times, stops 3s	No EC motor feedback	1. Check Modbus setting. 2. Check the EC motor.
Anti-frozen protection	Green LED blinks 12 times, stops for 3s	When unit is standby, Tr<2°C.	1. Turn on unit to keep Tr high than 5°C

E. Control Specifications: Flexible Function (W Type)

E.1. Features

- Integrated fan relays for zone control applications.
- ON/OFF thermostat input and low-voltage modulating fan speed input flexibility.
- Simple error diagnostic and LED error display.

E.2. I/O Port Definitions

I/O		Code	2-Pipe	4-Pipe
Analogue input	Coil temperature sensor	AI1	Cooling / heating coil sensor (Ti1)	Cooling only coil sensor (Ti1)
Voltage input	High fan speed	H	230VAC input signals from wired thermostat	
	Medium fan speed	M		
	Low fan speed	L		
	Phase	L1	External 230VAC power supply connection to the PCB.	
	Neutral	N1, N2		
	Earth			
Signal Input	Modulating signal	+/-	Low voltage modulating signal input (standard 0~5 VDC, S1=OPEN; optional 0~10VDC, S=CLOSED)	
Digital input	Programming interface	TTL	Low voltage digital signal input for board programming	
	Float switch	Float	Voltage-free (NC)	
Voltage output	Water pump	PUMP	Voltage output (L)	
	EC motor	CN4	5-wire connection	
	Stepping motor	CN1, CN2	Low voltage output	
Digital output	LED display	X-DIS	Low-voltage output	
Voltage-free output	Alarm	ALARM	Voltage-free alarm contact: (a) Standard configuration is (NC) and (NO).	

E.3. Onboard configuration

The PCB can be configured for different modulating signal inputs. Refer to jumper configuration table below.

Code	State	Description
S1	Open	PCB configured for 0~5VDC modulating signal input.
S1	Closed	PCB configured for 0~10VDC modulating signal input.
S3	N/A	Reserved
S4	N/A	Reserved

E.4. Wiring Diagrams

E.4.1. Standard EC-W1 Control PCB

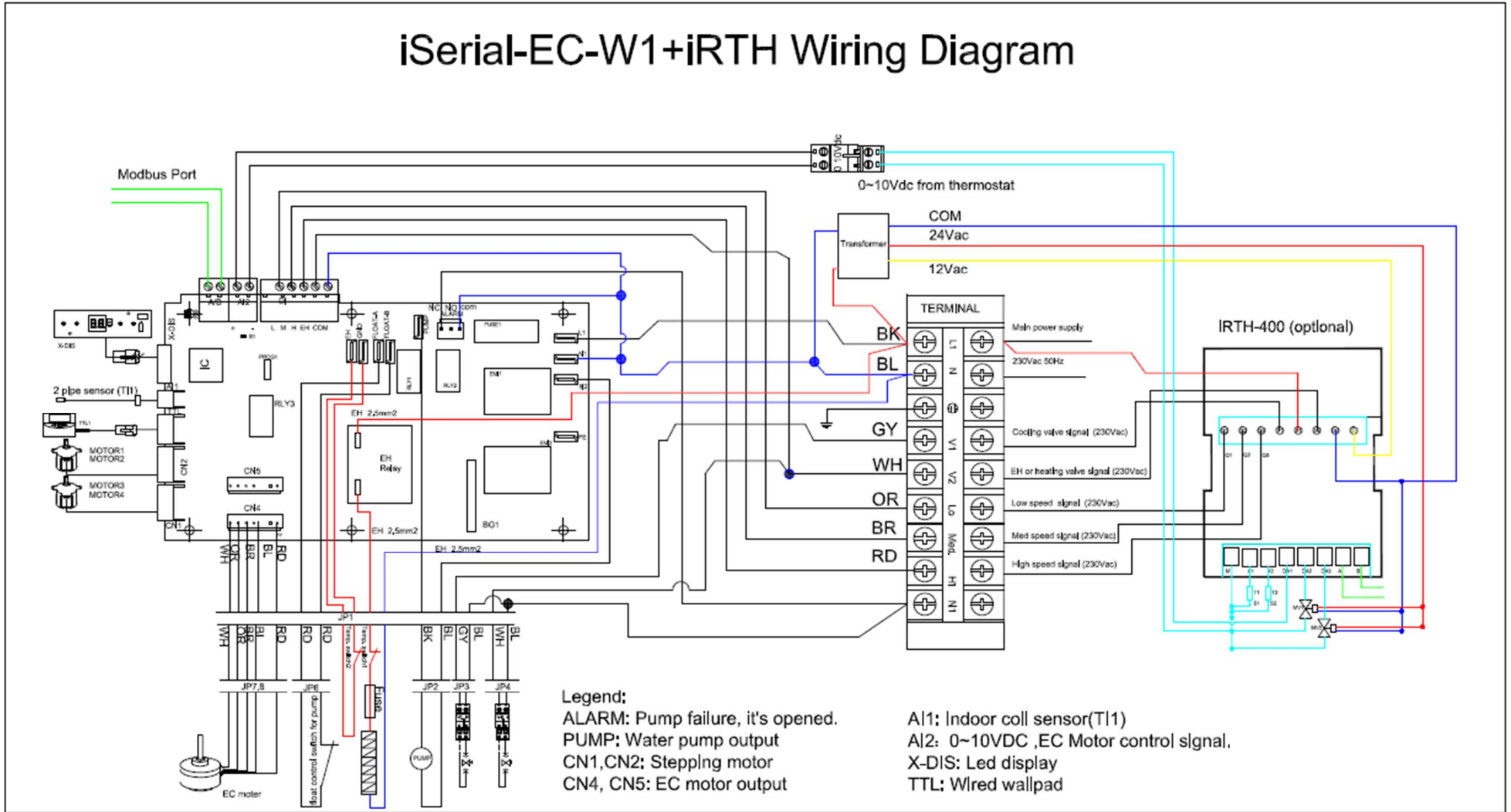

E.5. Control Logics Specification

E.5.1. Unit Power ON/OFF

- The unit is turned ON when any of the fan speed inputs (H/M/L) are ON, or modulating signal input is more than 2.0 VDC.
- The unit is turned OFF only if all of the fan speed inputs (H/M/L) are OFF and modulating signal input is less than 2.0 VDC.

E.5.2. Alarm Protection and Error Display

- If the float switch is open for 5 minutes or EC motor is failure, then the (NC) voltage-free alarm contact shall be open and the (NO) voltage free alarm contact shall be closed.
- If the float switch is open for 10 minutes or EC motor is failure, the LED display reports a condensate management failure (see table on the next page).

E.5.3. Drain Pump Operation

- When the unit turns ON:
 - If $Ti1 < 14^{\circ}\text{C}$, the drain pump turns ON.
 - If $14^{\circ}\text{C} \leq Ti < 16^{\circ}\text{C}$, the drain pan keeps original state.
 - If $Ti1 \geq 16^{\circ}\text{C}$, the drain pump turns OFF.
- When the unit turns OFF, the drain pump will remain ON for 5 minutes and then turn OFF.
- At any time:
 - If the float switch is OPEN, the drain pump will turn ON.
 - If the float switch is OPEN and then CLOSES, the drain pump will remain ON for 5 minutes, and then turn OFF.

E.5.4. Modulating Signal Input

- The standard configuration is for 0~5VDC modulating signal input.
- The optional configuration is for 0~10VDC modulating signal. To set the PCB to the optional configuration, the S1 jumper must be closed.

E.5.5. Low Temperature Protection of Indoor Coil in Winter

This is frost protection for when the unit is off to prevent water in the coil and room from freezing.

Unit is in Standby Mode

If $Ti1 \leq 2^{\circ}\text{C}$ for 2 minutes, report error code and Buzzer is beeping for 3minutes.

E.6. LED Display and Error Description

LED receiver in ABS housing with 0.5m (SGS14HFCA-01010101) or 1.8m (SGS14HFCA-01010102) pre-wiring



Flexible Function PCB – W Control Type		
Fan speed setting	LED Display	Condition
High speed	Red LED On	Normal
Medium speed	Yellow LED On	Normal
Low speed	Green LED On	Normal

For all units - Green LED Blinks			
Error Description	Blink	Reason	Remedy
Indoor coil sensor 1 failure	Green LED blinks 4 times, stops for 3s	Ti1 sensor connection is not good or damaged.	Check if Ti1 plug is connected or not. Check sensor's resistor is good or not.
Water pump failure	Green LED blinks 7 times, stops for 3s	Float switch is opened.	Check if the condensate water pipe is connected or not. Check if the pump is functioning or not.
EC motor failure	Green LED blinks 9 times, stops for 3s	No EC motor feedback	Check the EC motor
Anti-frozen protection	Green LED blinks 11 times, stops for 3s	When unit is standby, Ti1<2°C.	Turn on unit to keep Ti higher than 5°C

F. User Interface

F.1. Remote Handset

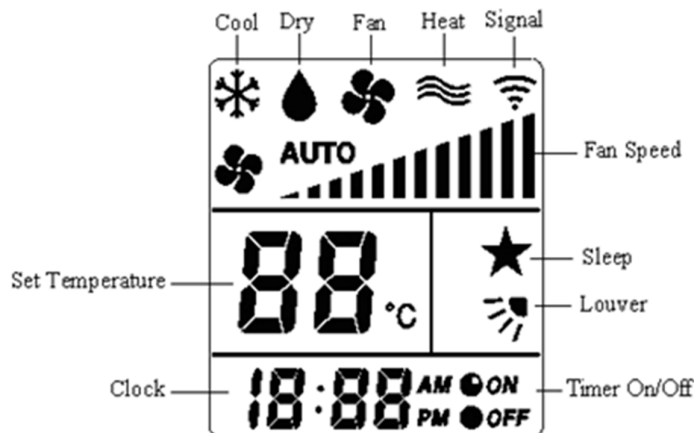
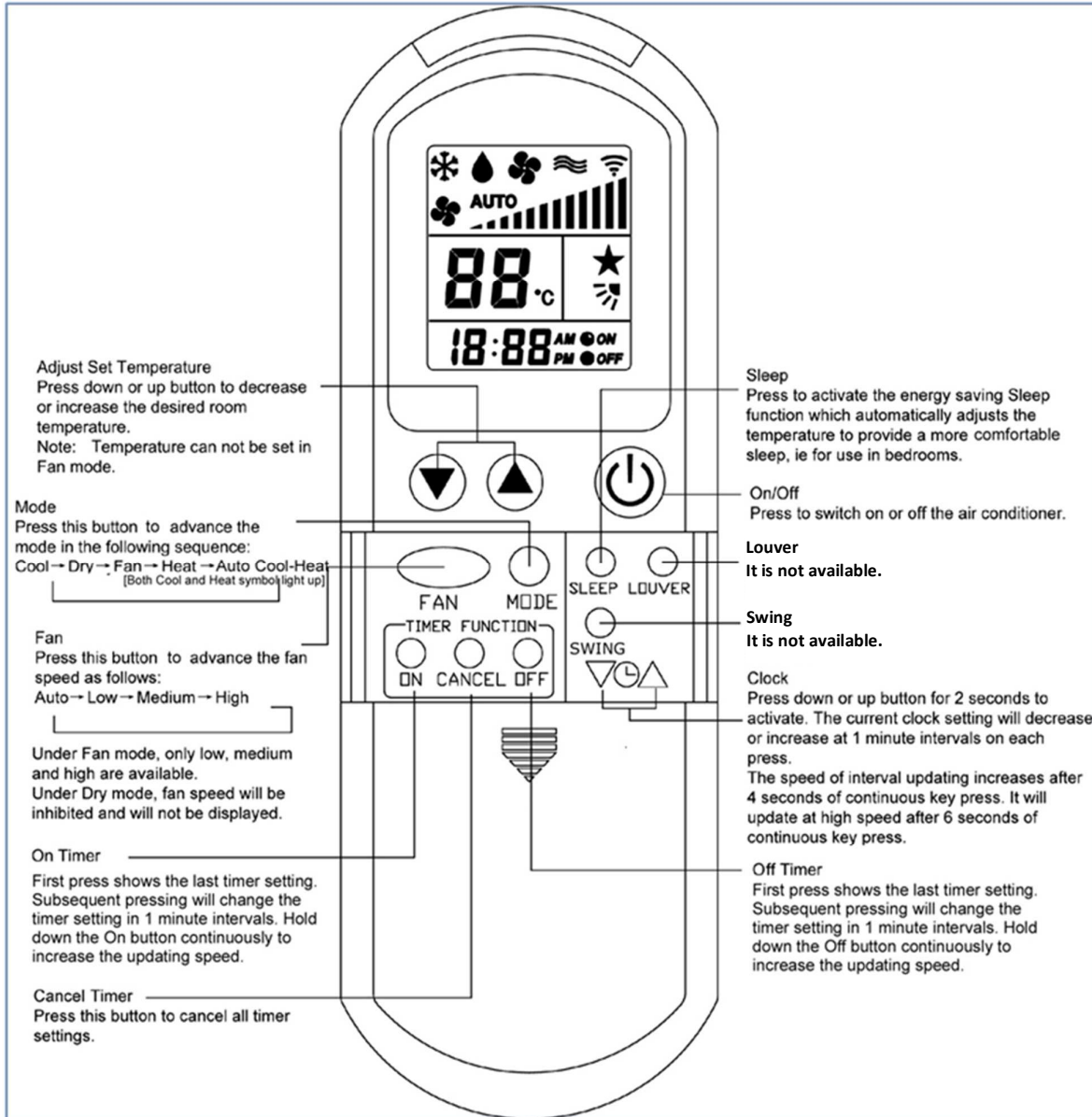

Attention

When unit with handset is the master unit, its settings are automatically sent to the slave units; Auto Cool-Heat operation will be applicable in 4-pipe system only.

“Swing” and “Louver” functions are not applicable.
European version only uses degree C setting.

F.2. Wired Wall Pad Controller





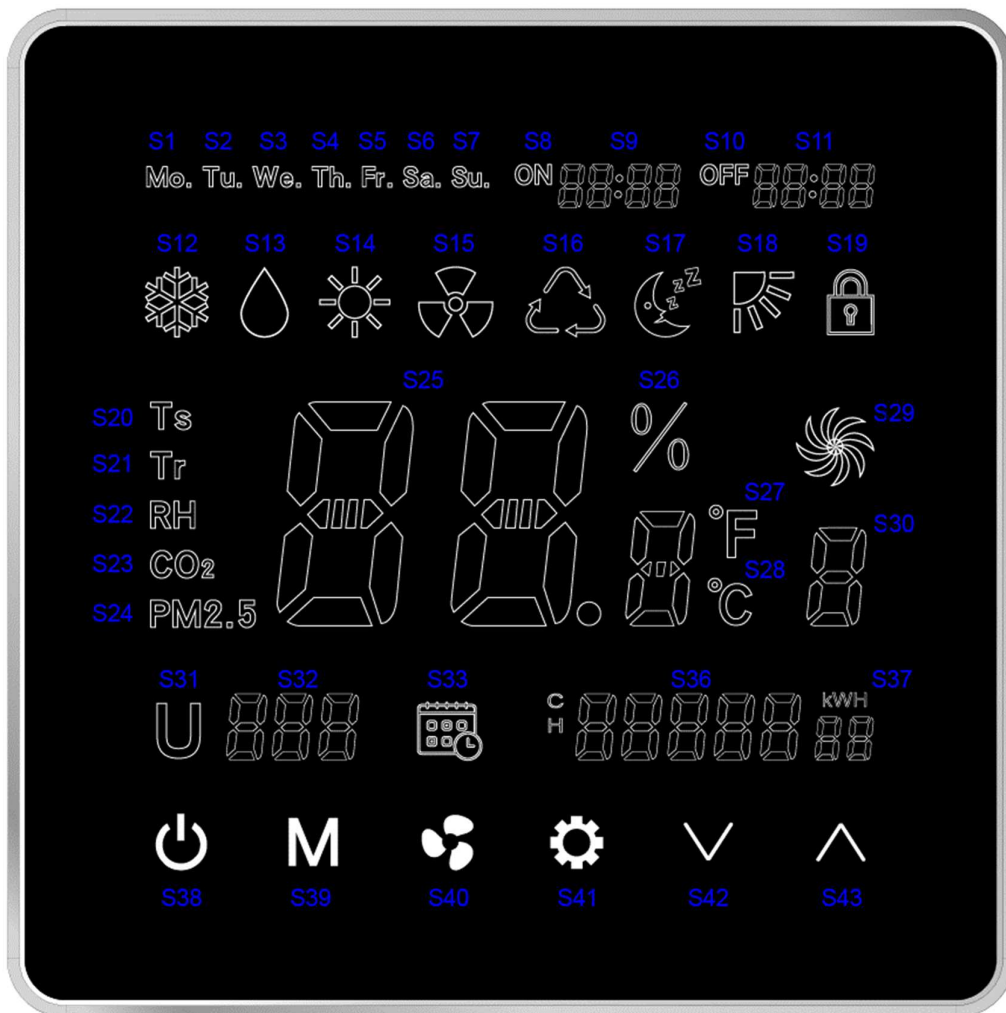























F.2.1. LED display









Code	Legend	Code	Legend	Code	Legend
S1	Monday	S16	Auto Mode	S31	Unit address
S2	Tuesday	S17	Sleep mode	S32	Unit No. / Error code
S3	Wednesday	S18	Swing mode	S33	Weekly timer
S4	Thursday	S19	LED lock	S34	C-cooling
S5	Friday	S20	Setting Temperature	S35	H-heating
S6	Saturday	S21	Room Temperature	S36	Energy consumption
S7	Sunday	S22	RH (if need)	S37	Energy consumption cycle
S8	Timer-ON	S23	CO2 density (if need)	S38	On/Off Button
S9	Timer-ON time (When Timer-ON is off: Current time)	S24	PM2.5 density (if need)	S39	Mode setting
S10	Timer-OFF	S25	Data Display	S38	On/Off Button
S11	Timer-OFF time	S26	RH percentage	S39	Mode setting
S12	Cooling Mode	S27	Fahrenheit degree	S40	Fan speed setting
S13	Dehumidification	S28	Celsius degree	S41	Parameter setting
S14	Heating Mode	S29	Fan	S42	Up
S15	Ventilation Mode	S30	0-Auto. 1-Low. 2- Medium. 3-High	S43	Down

F.2.2. Operation guide

S38	On/OFF Button	Press  to turn on. Press it again to turn off.
S39	Mode button	With wall pad on,  to select Cooling, Dehumidification, Heating, Ventilation or Auto sequentially.
S40	Fan Speed Button	Press  S30 to change from 0 to 3. 0=Auto speed, 1=Low speed, 2=Medium speed, 3=High speed.
S41	Parameter Setting Button	Long press  for 5 seconds to set today's day of week. Press  or  to change from Monday to Sunday.
		Long press  for 5 seconds then short press it once to set current time. Press  or  to change current time.
		Long press  for 5 seconds then short press it twice to set Timer ON. Press  to set day of week from Monday to Sunday. Press  or  to change Timer ON time. Press  to turn Timer ON on or off and S8 appears or disappears.

	<p>Long press  for 5 seconds then short press it 3 times to set Timer OFF time.</p> <p>Press  to set day of week from Monday to Sunday.</p> <p>Press  or  to change Timer OFF time.</p> <p>Press  to turn Timer OFF on or off and S10 appears or disappears.</p>
	<p>Long press  for 5 seconds then short press it 4 times to set group control and U31 appears. The function is reserved.</p>
	<p>Long press  for 5 seconds then short press it 5 times to set unit address and U32 appears.</p> <p>Press  or  to change unit address.</p>
<p>*** For MODBUS user only</p>	<p>Long press  for 5 seconds then short press it 6 times to set unit parameters. Press  to change the parameter type. Press  or  to change parameter setting value.</p> <p>S31/S32 displays “U001”, which is used to set unit type. 0=iAIR Mode: Ventilation T,RH, CO2, PM2.5 are displayed. 1=iFCU Mode: S12, S13, S14, S15, S16, S21 or S20 is displayed. 2=iAHU Mode: S12, S13, S14, S15, S16, S21 or S20 is displayed. 3=iAHU with air cleaner Mode: S12, S13, S14, S15, S16, T, RH, CO2, PM2.5 are displayed.</p> <p>S31/S32 displays “U002”, which is used to set unit of temperature degree. 0=Celsius degree. 1=Fahrenheit degree.</p> <p>S31/S32 displays “U003”, which is used to select display temperature on LCD. 1=Setting temperature. 0=Room temperature.</p> <p>S31/S32 displays “U004”, which is used to set setting temperature range. 0=Setting temperature is from 16~30°C. 1=Cooling setting temperature 24°C, Heating setting temperature 21°C.</p> <p>S31/S32 displays “U005”, which is used to set setting temperature band. 1~9°C.</p> <p>S31/S32 displays “U006-U009”, which are reserved to set parameters with optional accessory to measure PM2.5 and CO2 values.</p> <p>S31/S32 displays “U010~U011”, which are reserved.</p> <p>S31/S32 displays “U012”, which is used to set setting RH point. 30~70, default: 50</p> <p>S31/S32 displays “U013”, which is used to set setting RH band. 10~30, default: 10</p> <p>S31/S32 displays “U014”, which is used to set unit address. 1~255, default: 1</p> <p>S31/S32 displays “U015”, which is used to set unit ESP. 0~100%, default: 40% ,</p> <p>S31/S32 displays “U016”, which is reserved.</p>

		<p>S31/S32 displays "U017", which is used to set software. (please refer to different PCB)</p> <p>0=2-pipe with valve 1=2-pipe without valve 2=4-pipe with std valve 3=4-pipe with 6-way valve</p> <p>S31/S32 displays "U018", which is reserved.</p> <p>S31/S32 displays "U019", which is used to set DA1 function When U001=2,3 U019=0, fan control signal is based on Tr, Ts PID calculation U019=1, fan control signal is based on ESP PID calculation</p> <p>S31/S32 displays "U020", which is used to calibrate the sensor on the wired wall pad. -5~5, default: -3</p> <p>S31/S32 displays "U021", which is used to set EH function U021= 0, without EH. U021= 1, EH as booster. U021=2, EH as primary.</p> <p>S31/S32 displays "U022", which is used to select Tr sensor. 0=the sensor in the WWP. 1=the sensor in the PCB.</p> <p>S31/S32 displays "U023", which is used to display cooling and heating energy consumption. 0=S34/S35/S36/S37 disappears 1=S34/S35/S36/S37 appears In cooling and dehumidification mode, cooling energy consumption is shown. In heating mode, heating energy consumption is shown. 2=Motor running time is shown.</p> <p>S31/S32 displays "U024", which is used to set low speed RPM or control signal.</p> <p>S31/S32 displays "U025", which is used to set medium speed RPM or control signal.</p> <p>S31/S32 displays "U026", which is used to set high speed RPM or control signal.</p> <p>S31/S32 displays "U027", which is used to set Delta T OF Ti1/Ti2.</p> <p>S31/S32 displays "U028", which is used to set Delta T OF Ti3/Ti4.</p> <p>S31/S32 displays "U029", which is used to read unit type.</p> <p>S31/S32 displays "U030", which is used to read unit model.</p> <p>S31/S32 displays "U031", which is used to read unit manufacturing date.</p>
S32	Error code	<p>S32 : E** blinks</p> <p>Bit0 = Room temperature sensor error Bit1 = Ti1 temperature sensor error Bit2 = Ti2 temperature sensor error Bit3 = Float switch error Bit4 = Indoor coil low temperature protection Bit5 = Indoor coil overheat protection Bit6 = Filter switch Bit7 = Electrical heater failure Bit8 = Motor1 Error Bit9 = Motor2 Error</p>

		Bit10 = System parameters error Bit11 = Anti-frozen error Bit12 = Ti3 temperature sensor error Bit13 = Ti4 temperature sensor error Bit14 =PM2.5 sensor error Bit15 =AQI Error
Combination Button Function	Screen Lock Function Long press  for 5 seconds, S19 appears and screen is locked. Long press  for 5 seconds again, S19 disappears and screen is unlocked.	
	Swings Function Long press  for 5 seconds, S18 appears and swings is ON. Long press  for 5 seconds again, S18 disappears and swings is OFF.	
	Sleep Mode Long press  for 5 seconds, S17 appears and sleep mode is ON. Long press  for 5 seconds again, S17 disappears and sleep mode is OFF.	

F.2.3. Error Code List

Error Description	Code	Reason	Remedy
Room temperature sensor error	E1	Room sensor unplugged or damaged.	1. Check if Tr plug is connected or not.
			2. Check if sensor's resistance is correct or not.
Indoor coil sensor 1 failure	E2	Ti1 sensor unplugged or damaged.	1. Check if Ti1 plug is connected or not.
			2. Check if sensor's resistance is correct or not.
Indoor coil sensor 2 failure	E3	Ti2 sensor unplugged or damaged.	1. Check if Ti2 plug is connected or not.
			2. Check if sensor's resistance is correct or not.
Float switch error	E4	Float switch is opened.	1. Check if the condensate water pipe is connected or not.
			2. Check if the pump is functioning or not.
Indoor coil low temperature protection	E5	Water temperature is lower than 3 °C.	Check the water temperature.
Indoor coil over heat protection	E6	Water temperature is higher than 70 °C.	Check the water temperature.
Filter switch protection	E7	Filter Switch is open.	Replace or clean filter.
Electric Heater failure	E8	Only for unit with EH.	1. Change fan speed to high.
		EH safety switch is opened.	2. Replace the damaged EH safety switch.
EC motor failure(CN4)	E9	No EC motor feedback	1. Check Modbus setting.
			2. Check the EC motor.
EC motor failure(CN5)	E10	No EC motor feedback	1. Check Modbus setting.
			2. Check the EC motor.
Motor qty setting error (S6 PCB)	E11	Motor Qty setting error	1: check Modbus setting.
Anti-frozen protection	E12	When unit is standby, Tr<2°C.	1. Turn on unit to keep Tr high than 5°C
Indoor coil sensor 3 failure (S6 PCB)	E13	Ti3 sensor unplugged or damaged.	1. Check if Ti3 plug is connected or not.
			2. Check if sensor's resistance is correct or not.
Indoor coil sensor 4 failure (S6 PCB)	E14	Ti4 sensor unplugged or damaged.	1. Check if Ti4 plug is connected or not.
			2. Check if sensor's resistance is correct or not.
PM2.5 sensor failure (S6 PCB)	E15	PM2.5 sensor unplugged or damaged.	1. Check if PM2.5 plug is connected or not.
			2. Check if sensor's resistance is correct or not.
AQI sensor failure (S6 PCB)	E16	AQI sensor unplugged or damaged.	1. Check if AQI plug is connected or not.
			2. Check if sensor's resistance is correct or not.
Wired Wall Pad failure	E17	WWP unplugged or not well	1. Check plugs

F.2.4. Dimensions and installation

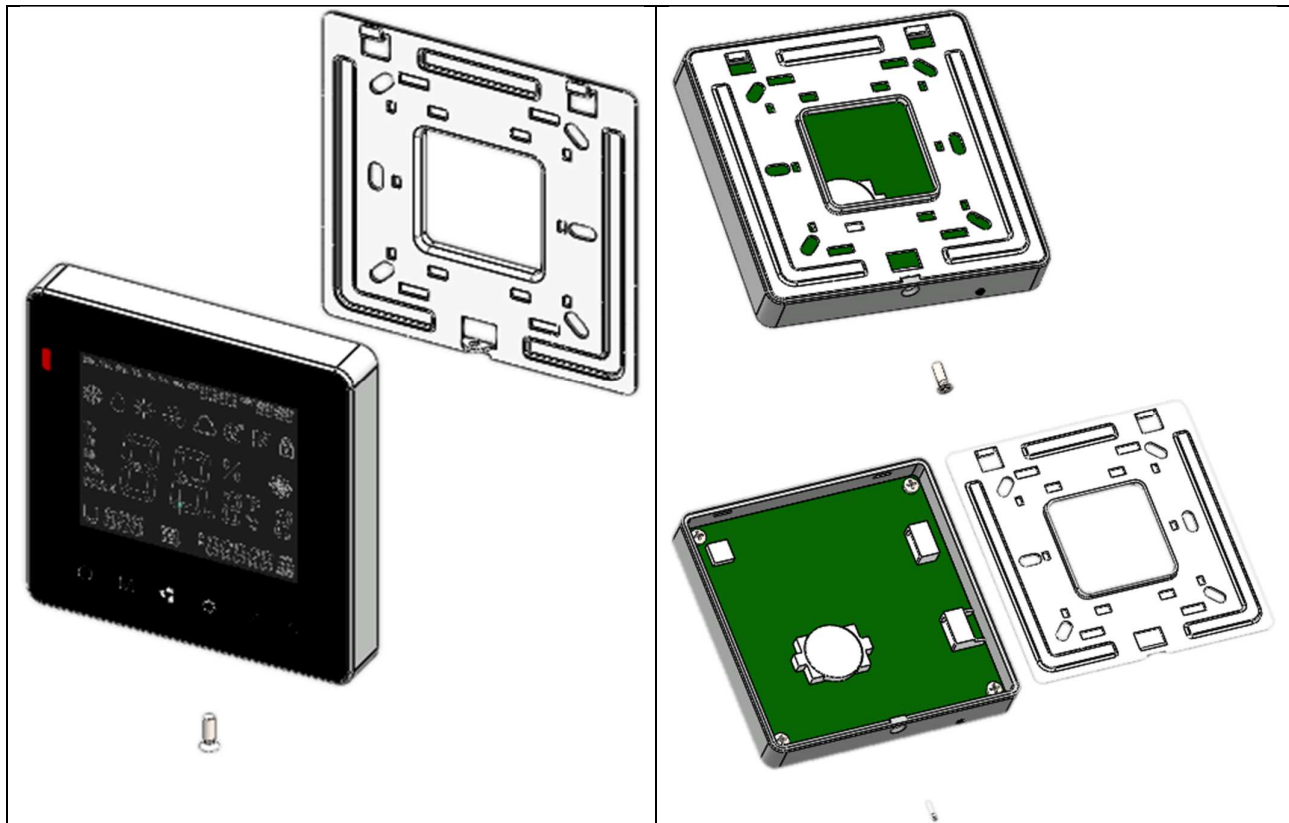
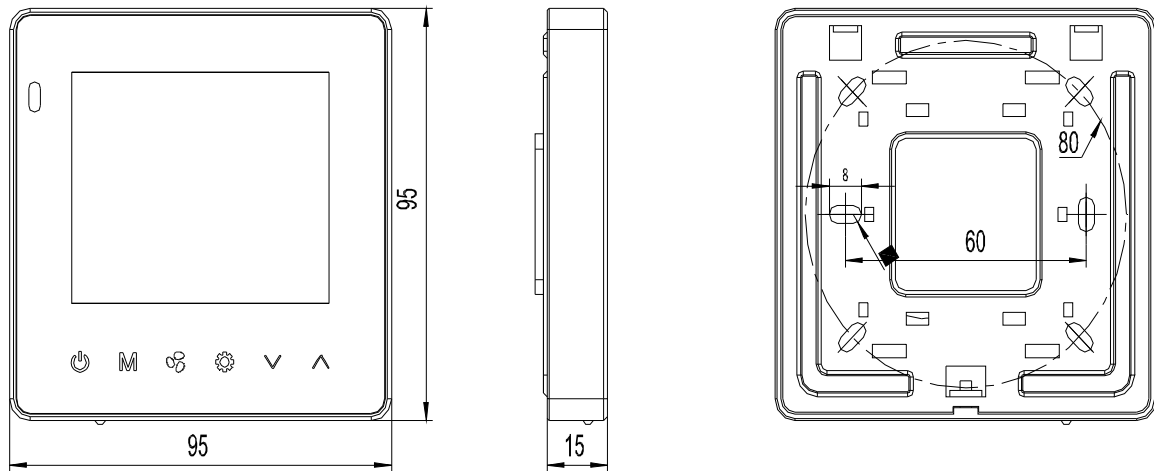

Use screw driver to remove the screw on the bottom

G. Sensor Resistance R-T Conversion Table

Resistance: $R(25^{\circ}\text{C}) = 10\text{K}\Omega \pm 1\%$ Beta Constant: $B(25/85) = 3950 \pm 1\%$

Temp. (deg. C)	Rmax (k Ohms)	Rnor (k Ohms)	Rmin (k Ohms)	Temp. (deg. C)	Rmax (k Ohms)	Rnor (k Ohms)	Rmin (k Ohms)
-30	186.3613	179.2666	172.4247	5	25.9521	25.4562	24.9672
-29	174.9608	168.4053	162.0793	6	24.6872	24.2274	23.7738
-28	164.3317	158.2726	152.4218	7	23.4912	23.0650	22.6443
-27	154.4170	148.8151	143.4022	8	22.3599	21.9650	21.5750
-26	145.1643	139.9837	134.9746	9	21.2897	20.9239	20.5622
-25	136.5254	131.7332	127.0964	10	20.2768	19.9380	19.6028
-24	128.4558	124.0216	119.7285	11	19.3178	19.0041	18.6937
-23	120.9146	116.8107	112.8348	12	18.4096	18.1193	17.8318
-22	113.8640	110.0648	106.3818	13	17.5493	17.2807	17.0146
-21	107.2691	103.7512	100.3387	14	16.7340	16.4857	16.2394
-20	101.0977	97.8396	94.6771	15	15.9612	15.7317	15.5040
-19	95.3201	92.3020	89.3705	16	15.2284	15.0164	14.8059
-18	89.9088	87.1124	84.3946	17	14.5333	14.3376	14.1432
-17	84.8385	82.2471	79.7268	18	13.8738	13.6933	13.5139
-16	80.0856	77.6837	75.3463	19	13.2479	13.0816	12.9160
-15	75.6284	73.4018	71.2336	20	12.6537	12.5005	12.3479
-14	71.4468	69.3823	67.3708	21	12.0895	11.9485	11.8080
-13	67.5220	65.6077	63.7412	22	11.5535	11.4239	11.2946
-12	63.8370	62.0616	60.3295	23	11.0442	10.9252	10.8064
-11	60.3755	58.7288	57.1212	24	10.5602	10.4510	10.3419
-10	57.1228	55.5953	54.1032	25	10.1000	10.0000	9.9000
-9	54.0651	52.6480	51.2629	26	9.6709	9.5709	9.4710
-8	51.1895	49.8747	48.5889	27	9.2623	9.1626	9.0630
-7	48.4842	47.2643	46.0705	28	8.8732	8.7738	8.6747
-6	45.9381	44.8062	43.6978	29	8.5025	8.4037	8.3052
-5	43.5409	42.4906	41.4615	30	8.1494	8.0512	7.9534
-4	41.2831	40.3086	39.3531	31	7.8128	7.7154	7.6184
-3	39.1559	38.2516	37.3644	32	7.4919	7.3953	7.2993
-2	37.1508	36.3117	35.4880	33	7.1859	7.0903	6.9953
-1	35.2603	34.4817	33.7169	34	6.8940	6.7995	6.7056
0	33.4771	32.7547	32.0447	35	6.6156	6.5221	6.4294
1	31.7945	31.1243	30.4652	36	6.3498	6.2576	6.1660
2	30.2064	29.5847	28.9728	37	6.0962	6.0051	5.9148
3	28.7068	28.1301	27.5623	38	5.8540	5.7642	5.6752
4	27.2904	26.7556	26.2286	39	5.6227	5.5342	5.4465

Temp. (deg. C)	Rmax (k Ohms)	Rnor (k Ohms)	Rmin (k Ohms)	Temp. (deg. C)	Rmax (k Ohms)	Rnor (k Ohms)	Rmin (k Ohms)
40	5.4018	5.3146	5.2283	77	1.4137	1.3722	1.3317
41	5.1907	5.1049	5.0199	78	1.3681	1.3275	1.2880
42	4.9890	4.9045	4.8210	79	1.3243	1.2845	1.2458
43	4.7961	4.7130	4.6309	80	1.2820	1.2431	1.2053
44	4.6117	4.5300	4.4494	81	1.2413	1.2033	1.1663
45	4.4354	4.3551	4.2759	82	1.2021	1.1649	1.1287
46	4.2667	4.1878	4.1100	83	1.1644	1.1279	1.0926
47	4.1053	4.0278	3.9515	84	1.1279	1.0923	1.0577
48	3.9508	3.8748	3.7999	85	1.0928	1.0580	1.0241
49	3.8030	3.7283	3.6548	86	1.0590	1.0249	0.9918
50	3.6614	3.5882	3.5161	87	1.0264	0.9930	0.9606
51	3.5258	3.4540	3.3833	88	0.9949	0.9623	0.9306
52	3.3960	3.3255	3.2562	89	0.9646	0.9326	0.9016
53	3.2715	3.2025	3.1346	90	0.9353	0.9040	0.8737
54	3.1523	3.0846	3.0181	91	0.9070	0.8764	0.8468
55	3.0380	2.9717	2.9065	92	0.8797	0.8498	0.8208
56	2.9285	2.8635	2.7996	93	0.8534	0.8241	0.7958
57	2.8234	2.7597	2.6972	94	0.8280	0.7994	0.7716
58	2.7227	2.6603	2.5990	95	0.8035	0.7754	0.7483
59	2.6260	2.5649	2.5049	96	0.7798	0.7523	0.7258
60	2.5333	2.4734	2.4147	97	0.7569	0.7300	0.7041
61	2.4443	2.3856	2.3282	98	0.7348	0.7085	0.6831
62	2.3589	2.3014	2.2452	99	0.7134	0.6877	0.6628
63	2.2768	2.2206	2.1656	100	0.6928	0.6676	0.6433
64	2.1981	2.1431	2.0892	101	0.6728	0.6482	0.6244
65	2.1224	2.0686	2.0159	102	0.6536	0.6295	0.6062
66	2.0498	1.9970	1.9455	103	0.6349	0.6113	0.5885
67	1.9800	1.9283	1.8779	104	0.6169	0.5938	0.5715
68	1.9129	1.8623	1.8130	105	0.5995	0.5769	0.5550
69	1.8484	1.7989	1.7507	106	0.5826	0.5605	0.5391
70	1.7864	1.7380	1.6908	107	0.5663	0.5447	0.5237
71	1.7267	1.6794	1.6332	108	0.5506	0.5293	0.5089
72	1.6694	1.6231	1.5779	109	0.5353	0.5145	0.4945
73	1.6142	1.5689	1.5247	110	0.5206	0.5002	0.4806
74	1.5612	1.5168	1.4736	111	0.5063	0.4863	0.4671
75	1.5101	1.4667	1.4245	112	0.4924	0.4729	0.4541
76	1.4610	1.4185	1.3772	113	0.4791	0.4599	0.4415

H. Troubleshooting

Symptoms	Cause	Remedy
The fan coil does not start up	No voltage	Check for presence of voltage Check fuse on board
	Mains switch in the "OFF" position	Place in the "ON" position
	Faulty room control	Check the room control
	Faulty fan	Check fan motor
Insufficient output	Filter clogged	Clean the filter
	Air flow obstructed	Remove obstacles
	Room control regulation	Check the room air sensor
	Incorrect water temperature	Check the water source
	Air present	Check the air vent
Noise and vibrations	Contact between metal parts	Check for loosening parts
	Loose screws	Tighten screws



Note: All the information or data in this manual may be changed without notice.

EUROPE

C / Rio Jucar, Nave 6 P.I El Saladar
Lorquí; Murcia, Spain 30564
Ph: (+34) 968 046 262

ASIA

6 On Ping St, R.6 - Block A, 9th Floor,
New Trade Plaza, Shatin, Hong Kong
Ph: (+852) 2648 8887

www.pghvac.com

contact@pghvac.com