



PURITY™ WHOLE HOUSE SYSTEM

Installation & Maintenance of the Fresh-Aire UV® Purity™ Whole House Air Purifier System

The **Fresh-Aire UV Purity™** germicidal ultraviolet light and filtration system offers the ultimate enhancement to indoor air quality. The system features three unique technologies (advanced filtration, germicidal UVC light, and photocatalytic oxidation) that improve indoor air quality by actively reducing airborne microbial contaminants and odor-causing volatile organic compounds.

The **Purity™** unit is installed directly onto the return side of the air handler or gas furnace.

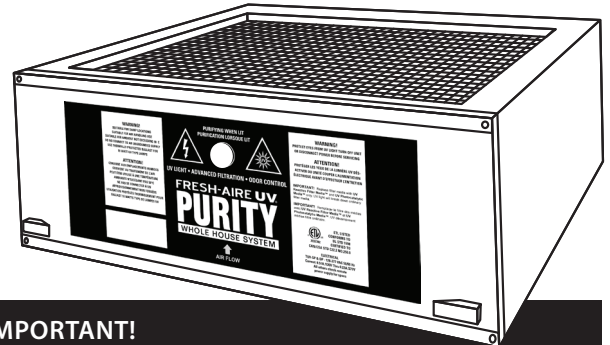

WARNING
PROTECT EYES FROM UV LIGHT
TURN OFF UNIT OR DISCONNECT
BEFORE SERVICING



IMPORTANT!

- Only qualified technicians should install this product*
- Install in accordance with relevant building codes
- Read instructions carefully including safety warnings

*Installation of this product by anyone other than licensed HVAC or electrical contractors voids warranty.

Parts Included

- A** Purity™ Housing
- B** UV Reactive Filter Media
- C** Photocatalytic (PCO) Media with UVC Lamp
- D** Self-Tapping Screws x 11
- E** Spade Connectors (ST Models) x 3
- F** Tap-In Connectors (ER Models) x 2

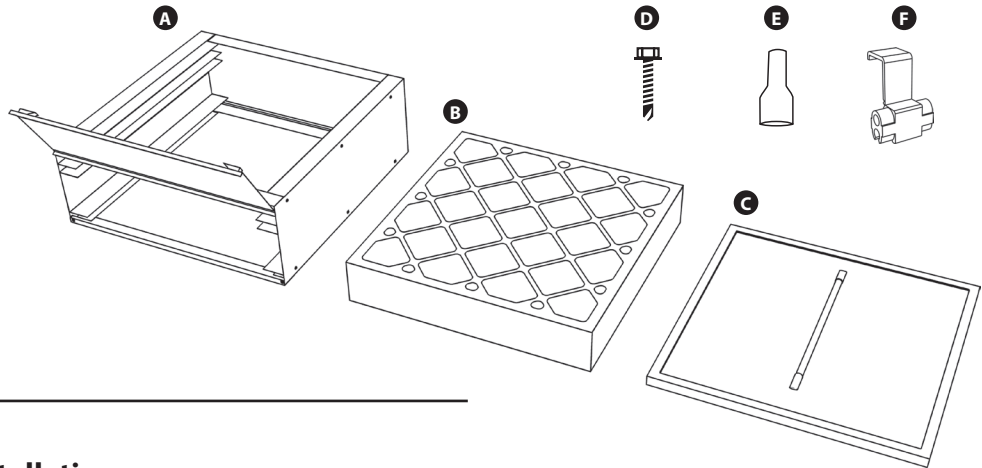

1 System Installation

1. Before installing **Purity™** remove the media guide-rails (to access screw holes). Rails are held in place with plastic rivets.

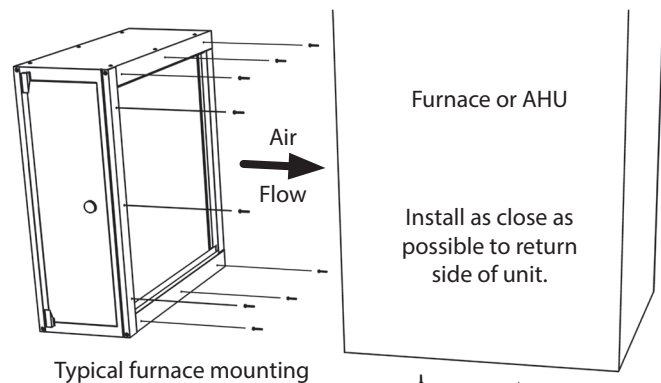
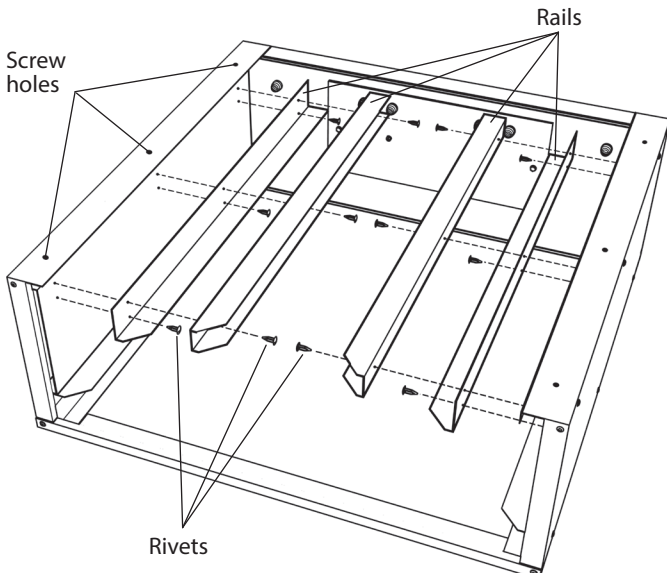

2. Attach **Purity™** housing to air system cabinet using self-tapping screws as shown.

3. Replace rails using plastic rivets.

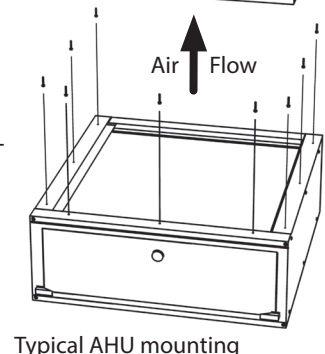

3 Power Supply

1. Remote mounted power supplies (ER, ST/DT models) are typically mounted in the control box of the air system and are connected to 110-277 VAC (ST/DT) or wired to the 24 VAC transformer there (ER). Use a separate 24 VAC transformer if needed - see warning.

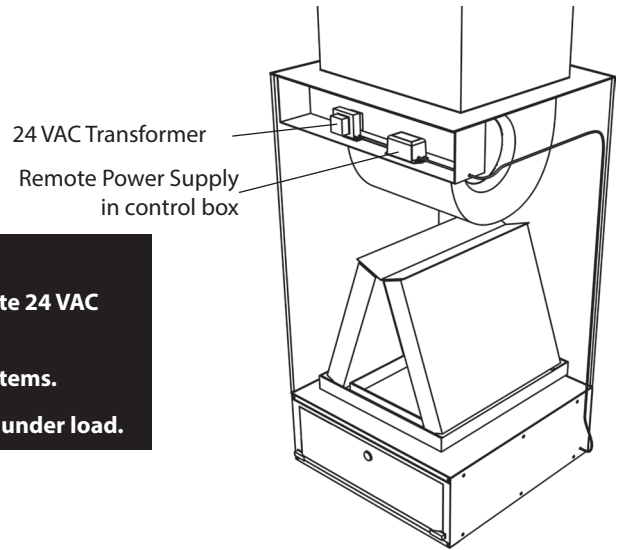

24 VAC WARNING!

Systems with high 24 VAC loads may require the installation of a separate 24 VAC transformer to power the Purity™ system.

Always use a separate 24 VAC transformer with “communicating” air systems.

Draws 16 VA, may need to do load calculation: Volts under load X Amps under load.

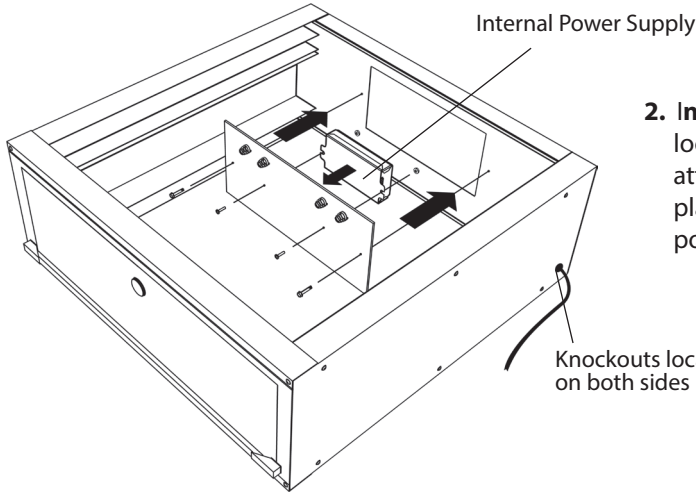

2. Internal power supplies (SP/DP models) are located inside the **Purity™** housing and are attached to the back of the removable belly-plate. Remove the belly-plate to replace the power supply.

3. Power cables pass through a knockout hole on the side of the **Purity™** housing. If access is limited pass the cables through the alternate knockout located on the other side.

IMPORTANT! Must be wired to constant power - do not connect to blower relay.

4. Wiring

External ER Power Supply
18-32 VAC

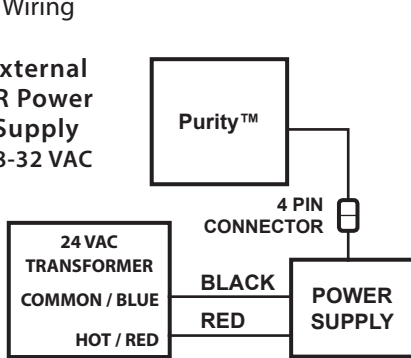

External ST, DT Power Supplies
110-277 VAC

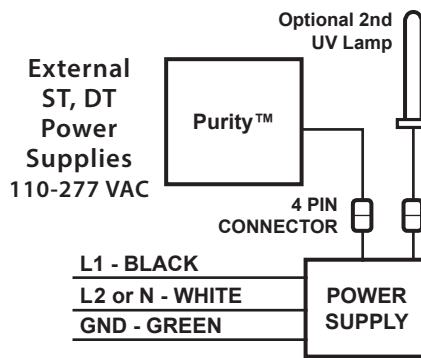

Internal SP, DP Power Supplies
110-277 VAC

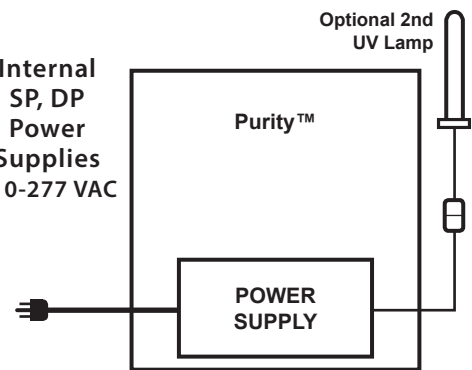

3 Insert Media

Insert media as shown. Be sure to orient the photocatalytic media so that the **UV lamp** faces the other filter not outward.

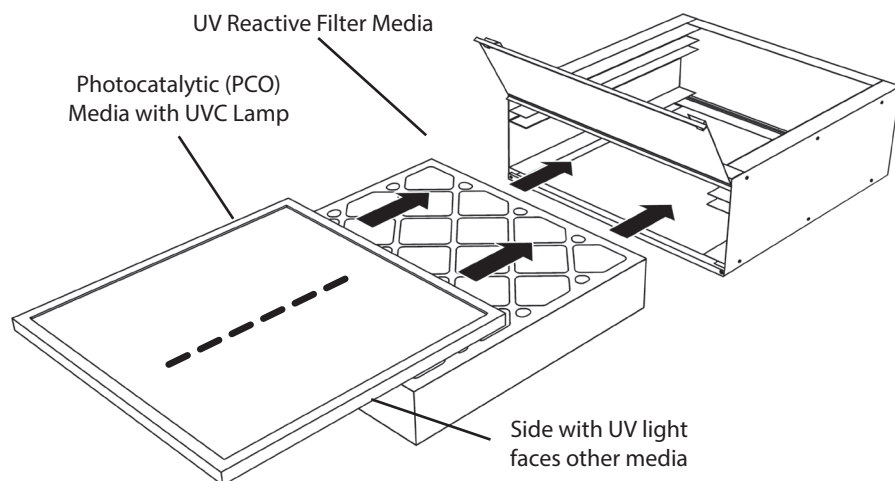

4 Interlock

To turn on the **Purity™** system after installation close the access panel (which closes a spring loaded interlock switch) and rotate the **door latches** to the closed position. Opening the **access panel** switches off power system for system maintenance.

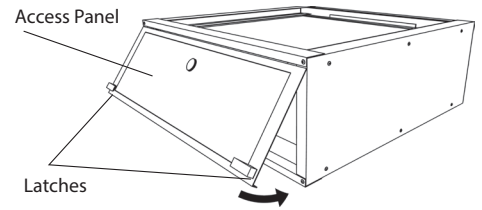

5 Replacing Media

Replace **PCO Media** (which includes the UVC light) every 2 years. Although the UV light will still glow, after 2 years the germicidal effectiveness will fall off. Replace with **part # TUVLM-PRT**.

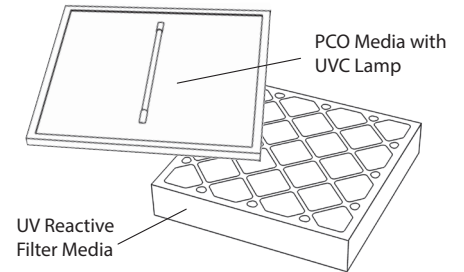

The **UV Reactive Filter Media** should be changed every six months, however, it may last up to a full year depending on local conditions. Replace with **part # TUV-RFM-4-XXYY**.

9 Trouble Shooting

Problem	Solution
UV Lamp(s) Not Lighting	<ol style="list-style-type: none"> 1. Check that power is applied. 2. Ensure the remote lamp cables are properly connected. 3. Reset power switch on power supply (off then on). 4. Install New UV Lamp(s). 5. Consult Factory.
UV Lamp(s) Flickering	<ol style="list-style-type: none"> 1. UV Lamp(s) have reached end of effective service life. Install new lamp(s) of same type. 2. If unit is new, check remote cables to ensure they are properly connected. 3. Reset power switch on power supply (off then on). 4. If new lamps still flicker, consult factory.
UV lamps burned out prematurely	<ol style="list-style-type: none"> 1. Consult Factory.
New UV lamps will not light - power supply problem	<ol style="list-style-type: none"> 1. Consult Factory. 2. External power suppressor may be needed if power surges occur.

Manufacturer's Warranty:

This warranty supersedes and replaces any warranty statements orally made by the Sales Person, Distributor or Dealer or contained in the written instructions or other Brochures or informational documents in relation to this product. This warranty gives you specific legal rights, and you may also have other rights which vary from State to State.

What Does This Warranty Cover? This lifetime limited manufacturer warranty covers any defects or malfunctions in material and workmanship under the normal use and service when operated and maintained in strict accordance with manufacturer's instructions for the Lifetime of the equipment.

How Long Does The Coverage Last? 1) Power Supply: For as long as you own the real property where the product is installed. 2) TUVL-1XX Series Ultraviolet Lamp is warranted for germicidal output for one-year from the date of installation. 3) TUVL-2XX Series Ultraviolet Lamp is warranted for germicidal output for two (2) years from the date of installation. This warranty is not transferable.

What Will Triatomic Environmental, Inc. Do? Triatomic Environmental, Inc. will replace any defective or malfunctioning part at no charge. You must pay any labor charges and shipping charges of defective product to our warranty department. **What Does This Warranty Not Cover?** THIS PRODUCT IS NOT INTENDED TO BE PURCHASED AND INSTALLED BY UNLICENSED HVAC OR ELECTRICAL CONTRACTORS. This warranty does not cover products or parts purchased from any source other than licensed HVAC or electrical contractors. This warranty does not cover parts installed by unlicensed HVAC or electrical contractors. This warranty does not cover parts damaged as a result of misuse, abuse, or any use other than its intended use, accident, acts of god, neglect, or from improper operation, maintenance, installation, modification or adjustments. Triatomic Environmental, Inc. shall have no responsibility for charges incurred by the customer for installation or removal of warranted items.

This warranty does not cover parts or equipment used with the Fresh-Aire UV system that are not manufactured by Triatomic Environmental, Inc.

**This warranty shall be void if UV lamps from manufacturer's other than Triatomic Environmental, Inc. are used with this equipment.

Consequential and incidental damages are not recoverable under this warranty. Manufacturer assumes no liability for any harm, which may occur as a result of the use of the equipment herein and shall not be liable for consequential or any other damages whether or not caused by manufacturer's negligence or resulting from any express or implied warranty or breach thereof. Consequential damages for the purpose of this warranty shall include, but not be limited to, loss of use, income or profit, or loss of or damages to property or injury or death to persons or animals occasioned by or arising out of operation, use, the operation, installation, repair or replacement of the equipment or otherwise. Some states do not allow the exclusion or limitation of incidental or consequential damages, so the above limitation or exclusion may not apply to you.

There are no Warranties which extend beyond the description of the face hereof.

How Do You Get Service? In order to be eligible for service under this warranty you MUST return the warranty registration card or register online at www.freshaireuv.com. If something is wrong with your product, call your installing contractor to receive a Return Merchandise Authorization (RMA) and instructions for returning the product to a licensed distributor in your area or the manufacturer.

Once the product is returned, we will inspect your product and contact you within 10 business days of our receipt of the product to give the results of our inspection. If we determine that the product is covered under this warranty, we will ship to you at no additional cost a replacement part. Replacement parts may be refurbished. If we determine that the product is not covered under this warranty, or that this warranty is void, the product will be returned to you COD. There is no charge for inspection.

How Does State Law Apply? This warranty gives you specific legal rights, and you may also have other rights which vary from state to state.



Manufactured by Triatomic Environmental, Inc.
WWW.FRESH-AIREUV.COM
sales@freshaireuv.com



© 2014 Fresh-Aire UV TUVL-PRT-MAN 7.24.14

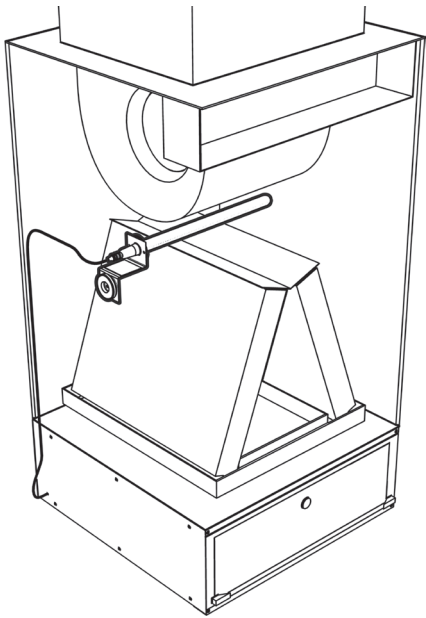

Optional 2nd Remote UV Light Installation Instructions

The optional **Fresh-Aire Remote UV Light** works with the **Purity™** system for enhanced disinfection, reduced system maintenance, and improved indoor air quality.

IMPORTANT!

- Purity™ Dual lamps are wired in series - both must be connected for lamps to light
- Only qualified technicians should install this product
- Install in accordance with relevant building codes
- Read instructions carefully including safety warnings

Installation Notes

Before installing the **Fresh-Aire Remote UV Light** it is necessary to determine the optimal mounting location inside the air system. First, look for the area with the heaviest mold growth. Also consider a location that will allow the germicidal UV light to shine on the greatest surface area.

Optional 2nd UV Light Parts

- A** UV Lamp 1 Year (TUVL-115P)
- B** UV Lamp 2 Year (TUVL-215P)
- C** Sight Glass
- D** "Z" Mounting Bracket
- E** Warning Sticker

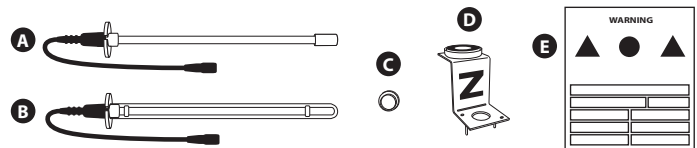

Note: lamp **A** or **B** and parts **C D E** are included with Purity™ Dual.



WARNING
PROTECT EYES FROM UV LIGHT
TURN OFF UNIT OR DISCONNECT
BEFORE SERVICING



IMPORTANT: Some materials inside the air system (including filter media, flex duct, wiring etc.) may not be UV light resistant. Use the optional UV shield (part #TUV-SHIELD-LP) or cover the materials with reflective tape.

1 Air Handler Interior Surface Installation

1. Determine the optimal position for placement of the **UV lamp**.
2. Use a utility knife to cut a slit in the insulation on the interior surface.
3. Place the magnetic **"Z" bracket** directly on the metal surface or remove the magnet and hard-mount the bracket using the **self-tapping screws** provided. Use foil tape to close the cut in the insulation.
4. Use plastic **quick-nuts** to attach the **UV lamp** to the **"Z" bracket** as shown.

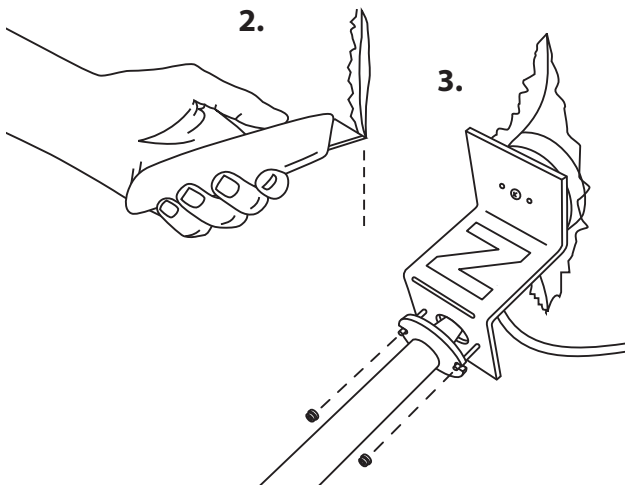

2 Coil "A" plate or Duct Installation

1. Snap the **"Z" bracket** apart by bending.
2. Drill a 1" hole in the "A"-plate or duct then attach the smaller piece of the bracket using the **self-tapping screws**.
3. Insert the **UV lamp** into the hole then use the plastic **quick-nuts** to attach the **UV lamp** to the **"Z" bracket** as shown.

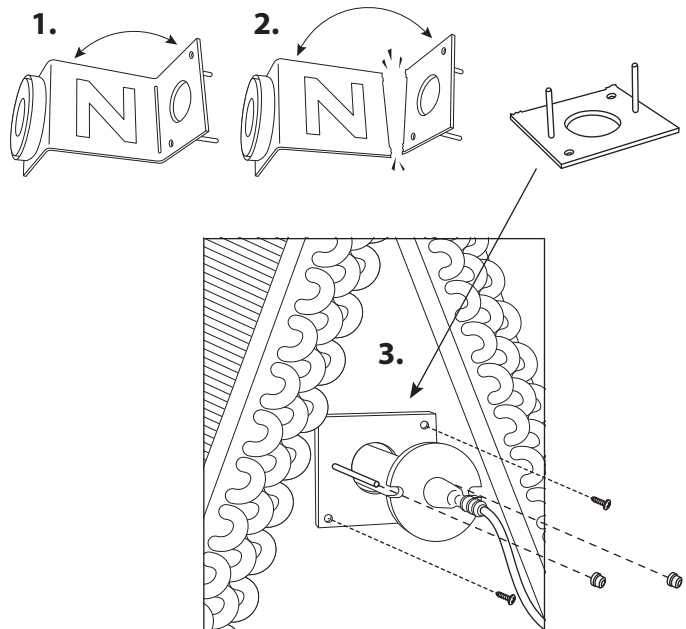

5 Remote UV Light Configuration

IMPORTANT! Only the **Purity™ Dual** model (with the **ST Power Supply**) has the electrical capacity for the optional **Remote UV Light**. The cable for the remote lamp passes through the knockout on the left side of the **Purity™ Housing**.

To add a second UV light to an existing **Purity™** system that is not a **Dual** model install a separate **Fresh-Aire UV AHU Series 1** or **Blue-Tube UV** system.

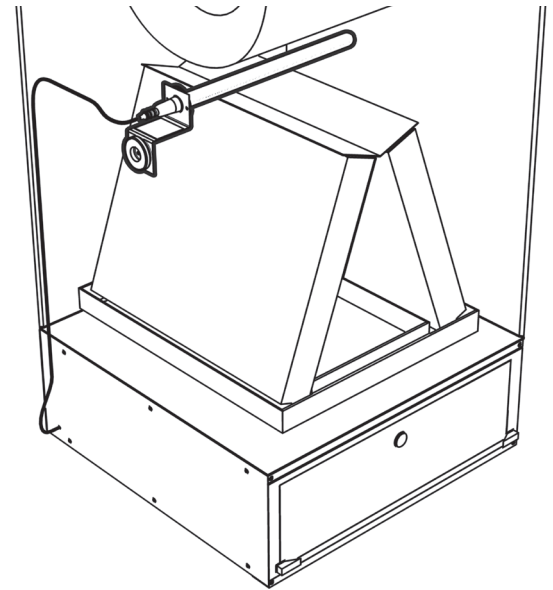

6 Remote UV Lamp Connection

1. When all the other components are properly installed connect the UV Lamp cable to the **Purity™** power supply cable.
2. Make sure the flanges are aligned and then push the connectors firmly together. A tight connection ensures a proper water-resistant seal.

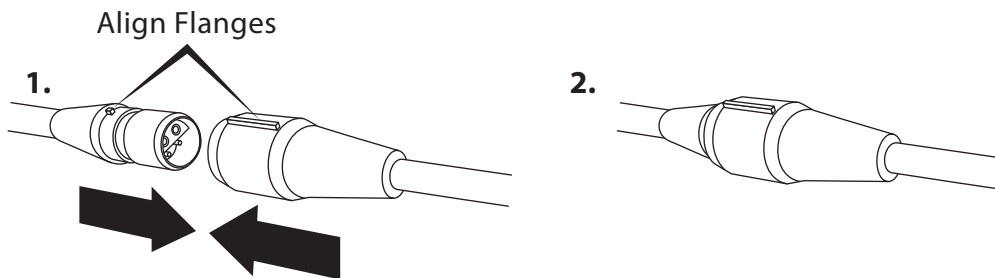

7 Sight Glass Installation

1. Find a suitable location on the outside of the duct-work near the UV Lamp installation and apply the **Fresh-Aire UV®** warning/lamp replacement sticker.
2. Drill a ½" hole through the orange circle on the sticker. Press the **UV safety viewport** into hole.
3. Turn on the power and use the **sight glass** to confirm that the **UV Lamp** is operating.

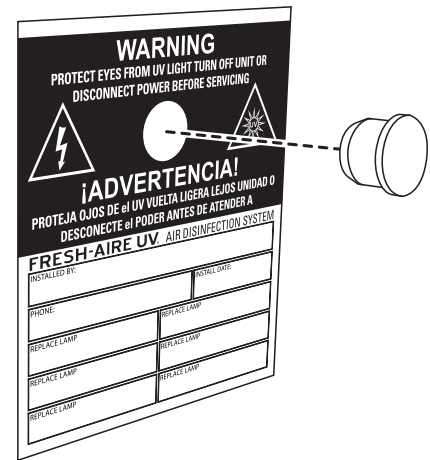

8 Lamp Replacement

The germicidal UV lamp in the **Fresh-Aire Remote UV Light** needs to be replaced periodically. A **TUVL-115P** lamp should be replaced every year. The **TUVL-215P** should be replaced every 2 years. Note: UV lamps will continue to emit visible light but lose germicidal effectiveness over time. You can upgrade to a 2 year lamp with your existing power supply.

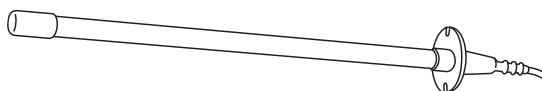

TUVL-115P
(1 Year)

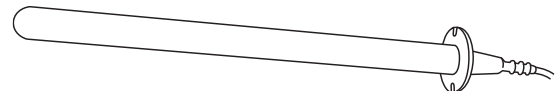

TUVL-215P
(2 Year)

CAUTION!

UV lamps contain small amounts of mercury - dispose of lamps in accordance with local environmental regulations. For more information visit www.lamprecycle.org

Note: Use of replacement UV lamps other than Fresh-Aire UV® voids warranty.