

Installation manual

CASCADE SETUP

Wall-hung high efficiency central heating boilers

CB 85 CH

CB 105 CH

CB 125 CH

CB 155 CH



INITIAL VERSION
E93.9950EN

Table of Contents

1. INTRODUCTION.....	4
2. INSTALLATION PROCEDURE CASCADE CONFIGURATION	5
3. DETERMINE POWER REQUIRED FOR THE CASCADE CONFIGURATION.....	6
4. CALCULATE DIMENSIONS AND SPACE OF CASCADE CONFIGURATION	8
5. EXPLANATION OF PARTS AND GROUPS	11
6. CONNECTING SETS	12
7. HYDRAULIC AND GAS HEADER GROUP.....	13
7.1 Headers	13
7.2 Support beam and support brackets	13
7.3 Headers and connecting sets.....	14
8. MOUNTING THE FRAME	15
8.1 Frame elements	15
8.2 Procedure for mounting the frame	16
9. MOUNTING THE GAS HEADER	17
10. MOUNTING THE BOILERS ON THE FRAME.....	18
11. MOUNTING THE HYDRAULIC GROUP AND THE CONNECTING SETS.....	19
12. MOUNTING THE LOW LOSS HEADERS	20
13. DETERMINE MANAGING AND DEPENDING BOILERS	21
14. COMPLETE THE MECHANICAL INSTALLATION	21
15. MOUNT THE FLUE GAS AND AIR SUPPLY SYSTEMS.....	22
15.1 Individual flue systems	22
15.2 Common flue system.....	22
16. SET PARAMETERS	23
17. COMMISSIONING THE CASCADE CONFIGURATION	23
18. ACCESSORIES.....	24
19. REFERENCES.....	24
19.1 List of figures	24
19.2 List of tables	24
20. APPENDIX A – CASCADE PARTS	25

1. Introduction

This Cascade manual is intended for the wall-hung high efficiency central heating boilers from the CB boiler series as manufactured by ECO Heating Systems.

The boilers can be combined in one cascade configuration. This ensures that the required power can always be achieved. Since several boilers are combined this allows for a deeper modulation range and for more precisely achieving the required level.

Furthermore the cascade configuration offers an increased reliability: should one boiler go into error, the cascade configuration will continue to operate.

ECO Heating Systems can supply standard cascade systems with mounting frame, piping and low loss headers for up to six boilers depending on the range. Larger amounts of boilers in a cascade combination are possible but require a dedicated system which must be designed separately.

The software allows for combining of up to 16 CB-boilers in a single cascade installation.

This document will offer you a general procedure for the complete installation of a cascade configuration. For specific details regarding connections, parameters, venting, etc. see the Installation & Service Manual of the boilers.



Figure 1.1 Typical cascade configuration

2. Installation procedure cascade configuration

In order to completely install a cascade configuration of two or more boilers, the following procedure should be observed:

1. **Calculate the total required amount of power for the cascade configuration and determine the number of boilers necessary in the cascade configuration to achieve the required power.**
This is described in detail in chapter 3.
2. **Determine the dimensions of the cascade set and the required space at the planned location.**
This is described in detail in chapter 4.
3. **Mount the frame.**
This is described in detail in chapter 8.
4. **Mount the gas header.**
This is described in detail in chapter 9.
5. **Mount the boilers on the frame.**
This is described in detail in chapter 10.
6. **Mount the hydraulic group and the connecting sets.**
This is described in detail in chapter 11.
7. **Mount the low loss header.**
This is described in detail in chapter 12.
8. **Determine which boiler is managing and which are depending.**
This is described in detail in chapter 13.
9. **Complete the mechanical installation of the cascade configuration.**
This is discussed in chapter 14.
10. **Mount the flue gas and air supply systems.**
This is discussed in chapter 15.
11. **Set the parameters in the software by means of the controller of each boiler.**
This is discussed in chapter 16.
12. **Commission the cascade installation.**
This is discussed in chapter 17.

3. Determine power required for the cascade configuration

The first step in the installation procedure for the cascade configuration is to determine the total power required for the cascade configuration. This power is calculated based on the size of the room(s) to be heated and other relevant variables. If the required power in kW is known, consult Table 3.1 (below) in order to determine which combination of boilers can be applied to achieve the required power.

Total Power *	CB 85 CH	CB 105 CH	CB 125 CH	CB 155 CH	Total number boilers	Cascade type
170	2				2	CCB-170-2-2000
187	1	1			2	CCB-187-2-1100
204		2			2	CCB-204-2-0200
210	1		1		2	CCB-210-2-1010
227		1	1		2	CCB-227-2-0110
236	1			1	2	CCB-236-2-1001
249			2		2	CCB-249-2-0020
253		1		1	2	CCB-253-2-0101
255	3				3	CCB-255-3-3000
272	2	1			3	CCB-272-3-2100
276			1	1	2	CCB-276-2-0011
289	1	2			3	CCB-289-3-1200
295	2		1		3	CCB-295-3-2010
302				2	2	CCB-302-2-0002
305		3			3	CCB-305-3-0300
312	1	1	1		3	CCB-312-3-1110
321	2			1	3	CCB-321-3-2001
328		2	1		3	CCB-328-3-0210
335	1		2		3	CCB-335-3-1020
338	1	1		1	3	CCB-338-3-1101
340	4				4	CCB-340-4-4000
351		1	2		3	CCB-351-3-0120
355		2		1	3	CCB-355-3-0201
357	3	1			4	CCB-357-4-3100
361	1		1	1	3	CCB-361-3-1011
374			3		3	CCB-374-3-0030
374	2	2			4	CCB-374-4-2200
378		1	1	1	3	CCB-378-3-0111
380	3		1		4	CCB-380-4-3010
387	1			2	3	CCB-387-3-1002
391	1	3			4	CCB-391-4-1300
397	2	1	1		4	CCB-397-4-2110
400			2	1	3	CCB-400-3-0021
404		1		2	3	CCB-404-3-0102
406	3			1	4	CCB-406-4-3001
407		4			4	CCB-407-4-0400
413	1	2	1		4	CCB-413-4-1210
420	2		2		4	CCB-420-4-2020
423	2	1		1	4	CCB-423-4-2101
426	5				5	CCB-426-5-5000
427			1	2	3	CCB-427-3-0012
430		3	1		4	CCB-430-4-0310
436	1	1	2		4	CCB-436-4-1120

Total Power *	CB 85 CH	CB 105 CH	CB 125 CH	CB 155 CH	Total number boilers	Cascade type
440	1	2		1	4	CCB-440-4-1201
446	2		1	1	4	CCB-446-4-2011
453				3	3	CCB-453-3-0003
453		2	2		4	CCB-453-4-0220
456		3		1	4	CCB-456-4-0301
459	1		3		4	CCB-459-4-1030
472	2			2	4	CCB-472-4-2002
476		1	3		4	CCB-476-4-0130
479		2	1	1	4	CCB-479-4-0211
486	1		2	1	4	CCB-486-4-1021
489	1	1		2	4	CCB-489-4-1102
499			4		4	CCB-499-4-0040
502		1	2	1	4	CCB-502-4-0121
506		2		2	4	CCB-506-4-0202
511	6				6	CCB-511-6-6000
512	1		1	2	4	CCB-512-4-1012
525			3	1	4	CCB-525-4-0031
529		1	1	2	4	CCB-529-4-0112
538	1			3	4	CCB-538-4-1003
551			2	2	4	CCB-551-4-0022
555		1		3	4	CCB-555-4-0103
578			1	3	4	CCB-578-4-0013
604				4	4	CCB-604-4-0004
624			5		5	CCB-624-5-0050
650			4	1	5	CCB-650-5-0041
676			3	2	5	CCB-676-5-0032
702			2	3	5	CCB-702-5-0023
729			1	4	5	CCB-729-5-0014
748			6		6	CCB-748-6-0060
755				5	5	CCB-755-5-0005
775			5	1	6	CCB-775-6-0051
801			4	2	6	CCB-801-6-0042
827			3	3	6	CCB-827-6-0033
853			2	4	6	CCB-853-6-0024
880			1	5	6	CCB-880-6-0015
906				6	6	CCB-906-6-0006

* Figures in this column represent the nominal output in kW at 50 °C/30 °C

Table 3.1 Cascade power calculation table based on CB boilers

EXAMPLES

- 1) In case the required power is calculated at 275 kW, the table will show you that the required cascade type is CCB-276-2-0011 and that the cascade configuration should have 2 boilers: one CB 125 CH boiler and one CB 155 CH boiler.
- 2) In case the required power is calculated at 440 kW, the table will show you that the required cascade type is CCB-440-4-1201 and that the cascade configuration should have 4 boilers: one CB 85 CH boiler, two CB 105 CH boilers and one CB 155 CH boiler.

4. Calculate dimensions and space of cascade configuration

In this chapter is explained how to determine the dimensions of the cascade configuration and how much space is required in the room where the cascade configuration will be installed.

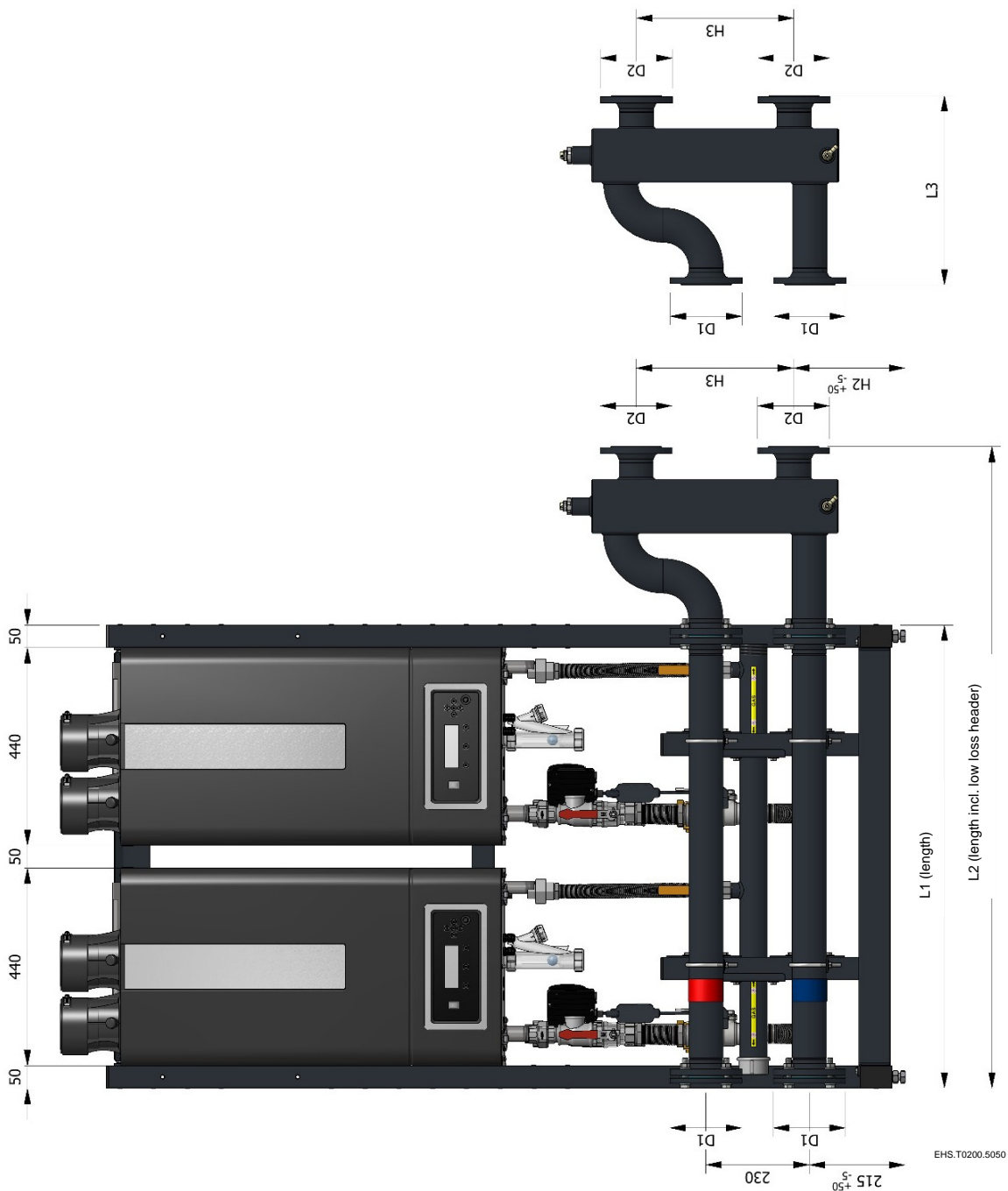

Figure 4.1 Dimensions front view

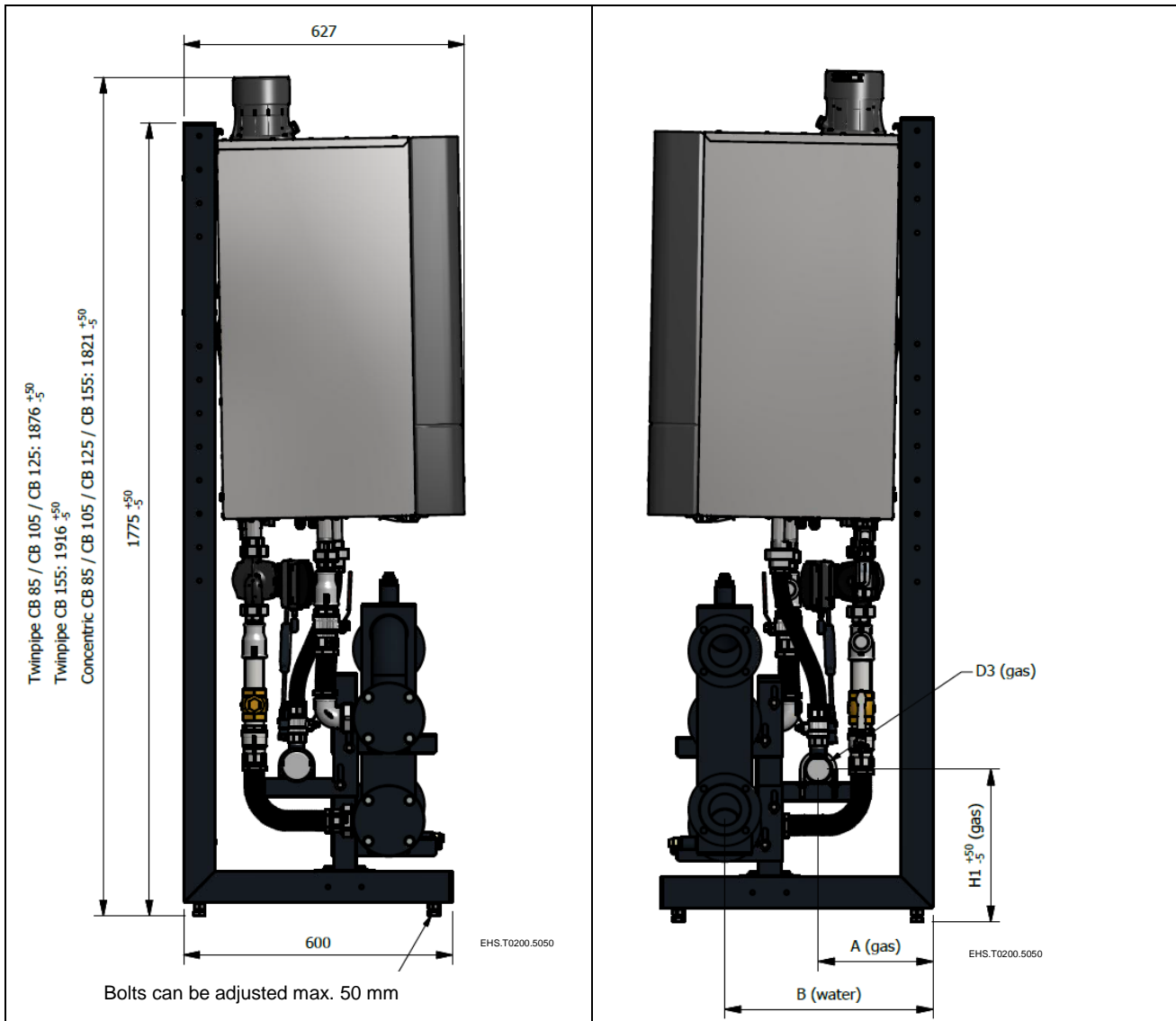

Figure 4.2 Dimensions: side views

After you have determined which cascade configuration will be applied and therefore how many boilers must be combined in the cascade configuration, the next step is to determine the total dimensions of the cascade configuration and the space required for the cascade configuration.

Figure 4.1 and Figure 4.2 show a schematic representation of a cascade configuration. The dimensional references in this figure (L1-L3, H1-H3, D1-D3, A, B) correspond with the dimensional references in the tables below.

EXAMPLES

In case a cascade configuration for 275 kW is required, which will exist of 2 boilers, refer to Table 4.1 for the dimensions of the cascade configuration. The table shows that frame length for this configuration is 1030 mm and the total length including the low loss header is 1428 mm.

In case a cascade configuration for 440 kW is required, which will exist of 4 boilers, refer to Table 4.2 for the dimensions of the cascade configuration. The table shows that frame length for this configuration is 2010 mm and the total length including the low loss header is 2408 mm.

All these dimensions have to be taken into account when determining the space required for placing the cascade configuration.

Number of boilers (up to 360 kW)	2 boilers	3 boilers	4 boilers
L1 (length frame)	1030	1520	2010
L2 (total length incl. header)	1428	1918	2408
L3 (length low loss header)	422	422	422
H1 (height gas)	308	308	308
H2 (height header coupling)	248	248	248
H3 (height couplings)	350	350	350
D1 (header connection size)	DN 65 PN6 (2½ ")	DN 65 PN6 (2½ ")	DN 65 PN6 (2½ ")
D2 (header connection size)	DN 65 PN6 (2½ ")	DN 65 PN6 (2½ ")	DN 65 PN6 (2½ ")
D3 (gas connection size)	R 2"	R 2"	R 2"
A (gas)	253	253	253
B (headers)	459	459	459

Table 4.1 Dimensions CB cascade up to 360 kW

Number of boilers (360 up to 540 kW)	3 boilers	4 boilers
L1 (length frame)	1520	2010
L2 (total length incl. header)	1938	2473
L3 (length low loss header)	487	487
H1 (height gas)	308	308
H2 (height header coupling)	257	257
H3 (height couplings)	380	380
D1 (header connection size)	DN 80 PN6 (3 ")	DN 80 PN6 (3 ")
D2 (header connection size)	DN 80 PN6 (3 ")	DN 80 PN6 (3 ")
D3 (gas connection size)	R 2"	R 2"
A (gas)	253	253
B (headers)	466	466

Table 4.2 Dimensions CB cascade 360 up to 540 kW

Number of boilers (540 to 930 kW)	4 boilers	5 boilers	6 boilers
L1 (length frame)	2010	2500	2990
L2 (total length incl. header)	2614	3104	3594
L3 (length low loss header)	628	628	628
H1 (height gas)	327	327	327
H2 (height header coupling)	272	272	272
H3 (height couplings)	420	420	420
D1 (header connection size)	DN 100 PN6 (4 ")	DN 100 PN6 (4 ")	DN 100 PN6 (4 ")
D2 (header connection size)	DN 100 PN6 (4 ")	DN 100 PN6 (4 ")	DN 100 PN6 (4 ")
D3 (gas connection size)	DN 80 (3")	DN 80 (3")	DN 80 (3")
A (gas)	253	253	253
B (headers)	482	482	482

Table 4.3 Dimensions CB cascade 540 to 930 kW

5. Explanation of parts and groups

Each cascade configuration exists of the following parts and groups:

1. The number of boilers as selected in chapter 3.
2. The frame group (with locking plates) as determined by the number of boilers.
3. An external pump for each boiler.
4. Connecting sets to connect the boilers to the hydraulic and gas header groups. Each connecting set contains one gas, one supply and one return pipe. More details can be found in chapter 6.
5. Hydraulic and gas header group, existing of 1 gas, 1 supply and 1 return header, including all mounting and connecting parts. More details can be found in chapter 7.
6. Low-loss header to connect the hydraulic group to the heating installation.

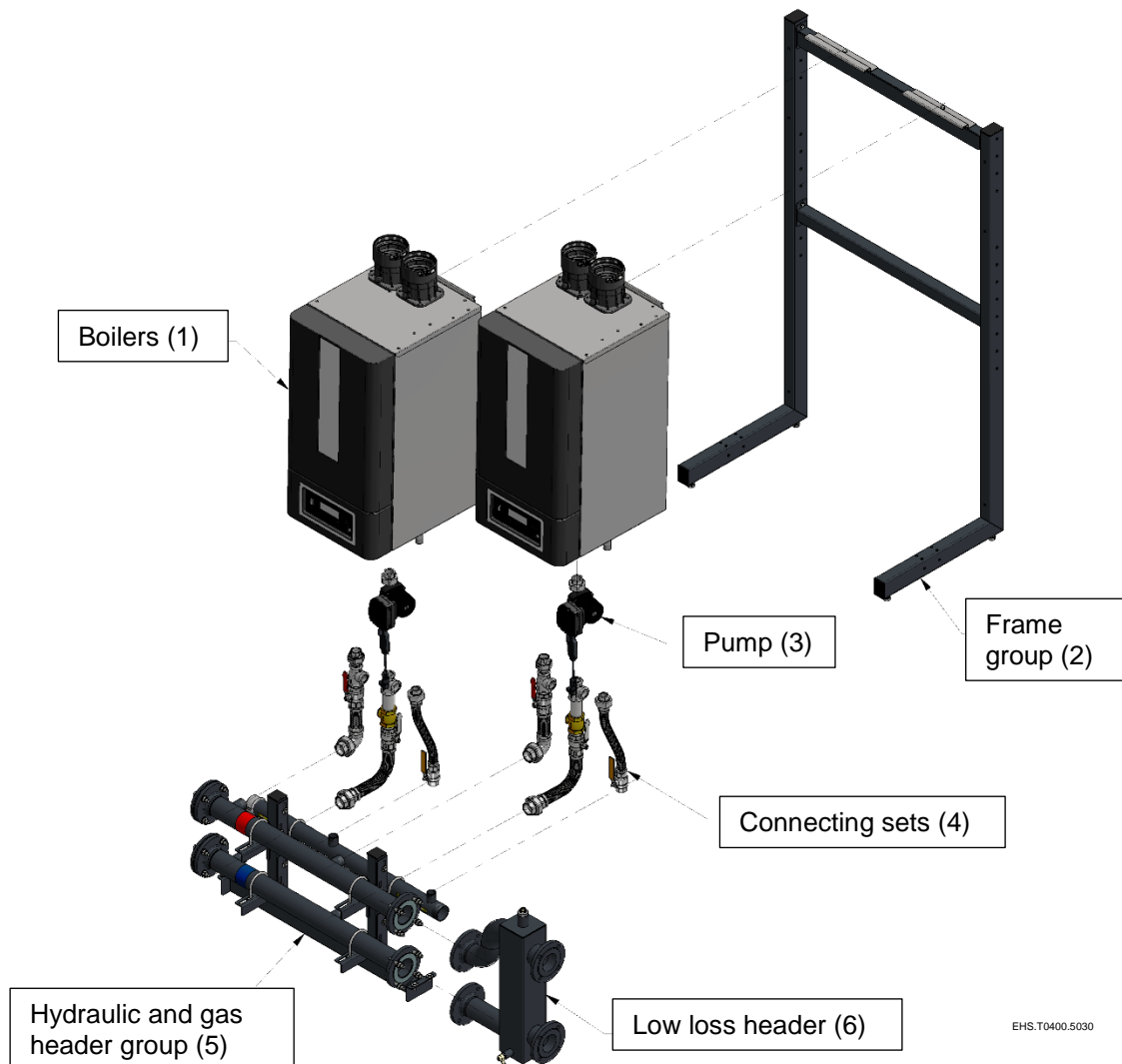
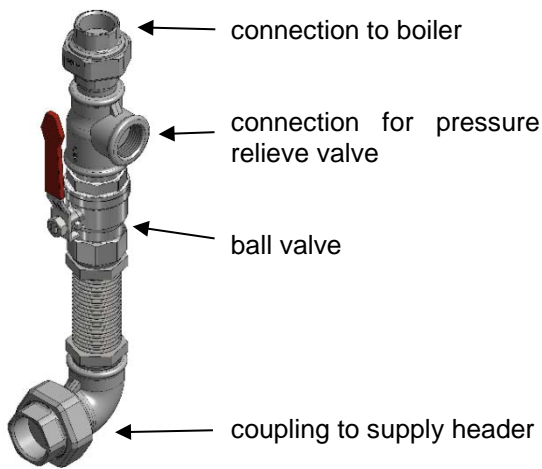

Figure 5.1 Cascade parts and groups

6. Connecting sets

Supply connecting set



EHS.T0700.5010

Gas connecting set

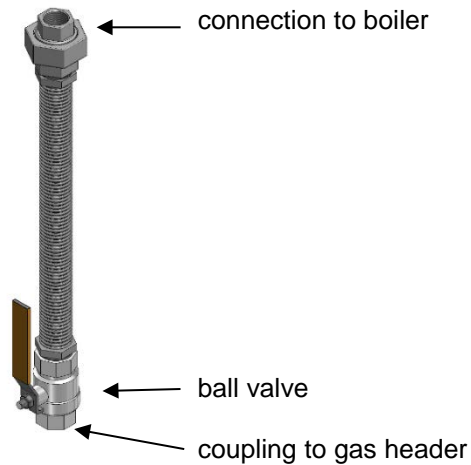

EHS.T0700.5010

Return connecting set with external pump

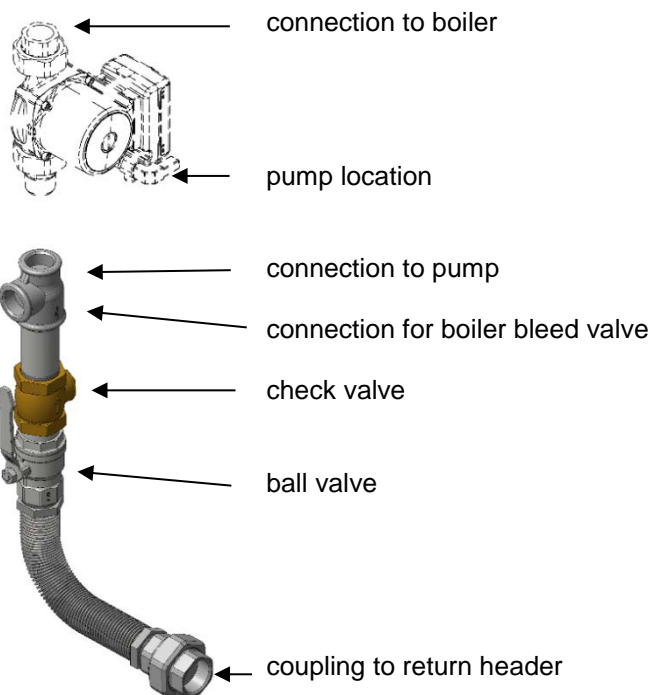

EHS.T0700.5010

Figure 6.1 Connecting sets

The gas connecting set should be connected to the gas connection on the boiler. The supply connecting set must be connected to the boiler supply connection (front connection on the boiler) and the return connecting set (longest) to the boiler return connection (back connection on the boiler). The open connection in the supply connecting set is meant for a pressure relief valve, and the open connection in the return connecting set is to be used for a boiler bleeding valve.

7. Hydraulic and gas header group

7.1 Headers

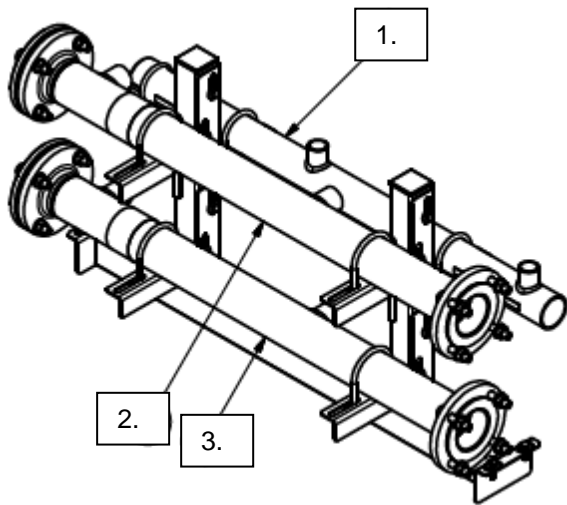

1. Gas header (yellow marking)
2. Supply header (red marking)
3. Return header (blue marking)

Figure 7.1 Parts hydraulic and gas header group

7.2 Support beam and support brackets

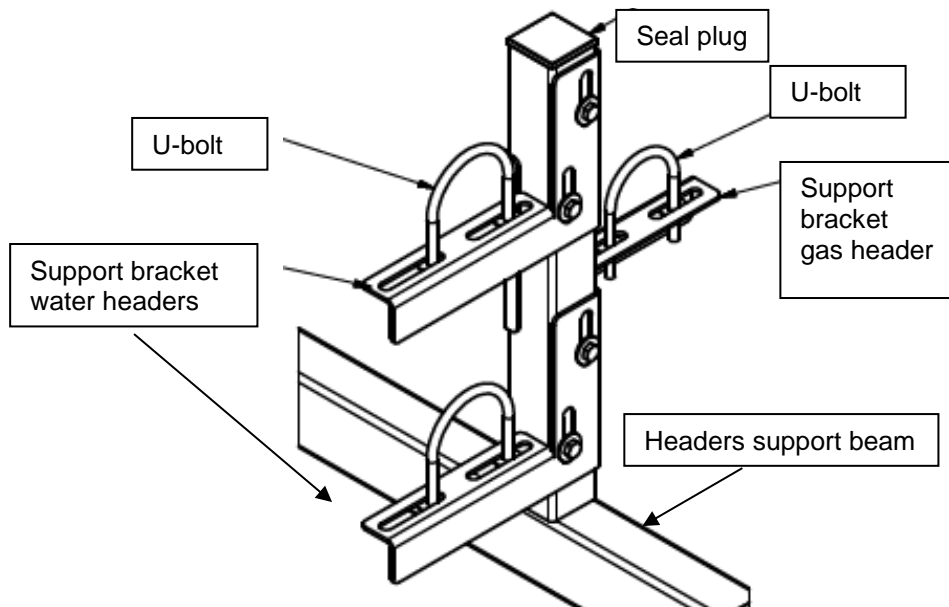

Figure 7.2 Headers support beam and support brackets

7.3 Headers and connecting sets

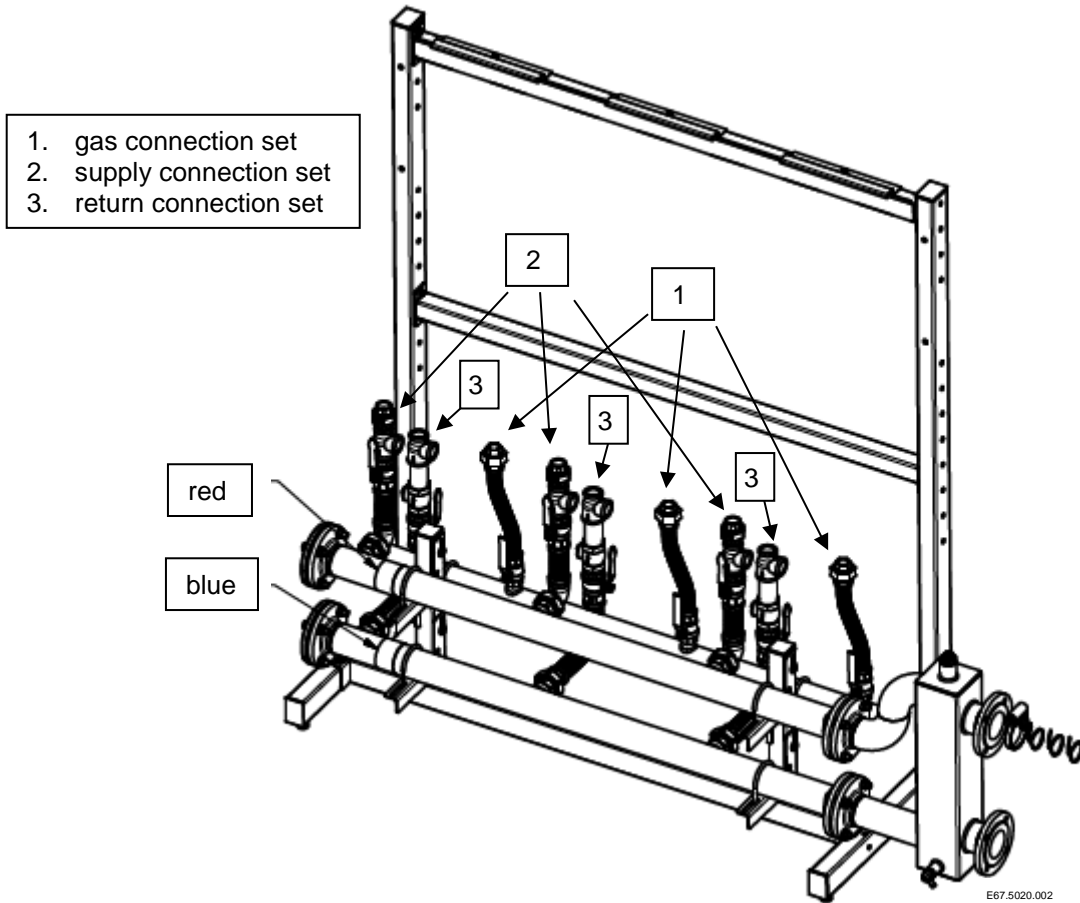

Figure 7.3 Headers and connecting sets

Variant sizes

Depending on the cascade configuration the headers come in the following size varieties:

Header	Varieties
Gas header	DN50 / DN80
Water header (supply and return)	DN65 / DN80 / DN100

See also Table 4.1, Table 4.2 and Table 4.3.

8. Mounting the frame

8.1 Frame elements

The first part of the actual installation of the cascade configuration is assembling the frame on which the boilers will be hung.

The basic frame exists of the following elements:

- L-shaped stands
- Top beam
- In-between beam (middle beam)
- Mounting material (bolts, washers)

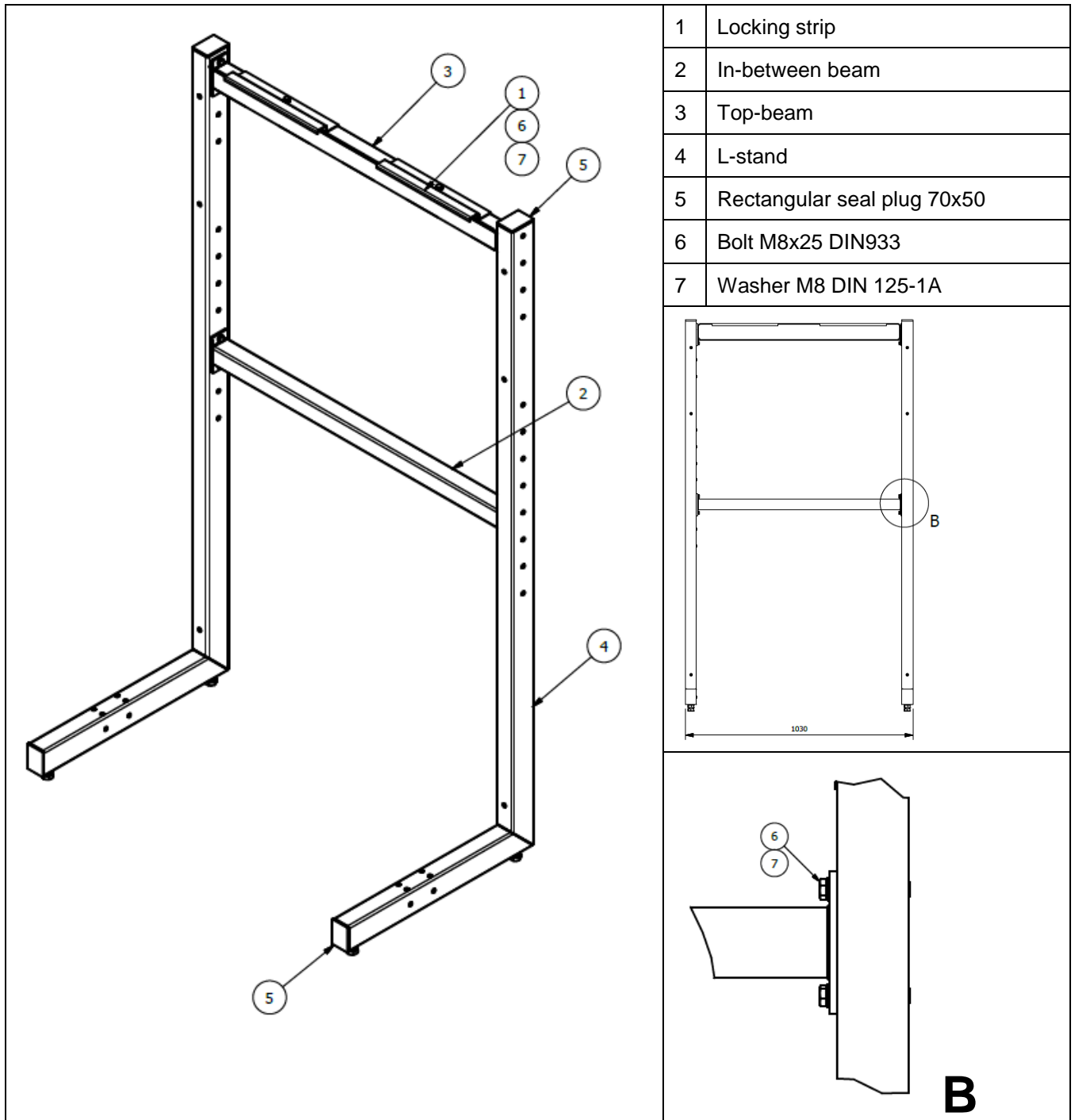

Figure 8.1 Frame elements

The number of elements to be mounted depends on the number of boilers which have to be combined.

# Boilers		# L-stands	# Top beams	# In-between beams	# Frame braces	Width beams
1*		2	1	1	1	440 mm
2		2	1	1	1	930 mm
3		2	1	1	1	1420 mm
4		3	2	2	2	930 mm
5	exists of a 2-boiler frame and a 3-boiler frame	3	1	1	1	930 mm
			1	1	1	1420 mm
6	option 1	3	2	2	2	1420 mm
	option 2	4	3	3	3	930 mm

* A frame can also be mounted for a single boiler, although a 1 boiler configuration does not fall within the cascade scope of this manual.

Table 8.1 Frame elements per cascade set

Attention!

Each set of material for the required cascade configuration will contain the exact amount of material required for the cascade configuration type ordered.

8.2 Procedure for mounting the frame

See also Figure 8.1.

To mount the frame, subsequently carry out the steps in the following procedure:

1. Check after unpacking that all parts are actually present.
2. Mount the in-between beam(s) between the L-stands.
Ensure that the beam’s flange hole falls over the raised edge of the L-stand connection hole.
Mount the beam(s) loosely; do not yet tighten the bolts.
3. Mount the top beam(s) between the L-stands.
Ensure that the beam’s flange hole falls over the raised edge of the L-stand connection hole
Mount the beam(s) loosely; do not yet tighten the bolts.
4. Level the L-stands, both vertically and horizontally.
Use a level and the adjustment bolts on the bottom of the L-stands.

Attention!

The frame must be levelled tension-free.
So do not tighten bolts or mount boilers before the frame has been levelled.

Attention!

After mounting the frame, the frame must be braced or mounted to the wall or ceiling to prevent the frame and boilers from wobbling.
Check the local building regulations for the relevant requirements.

9. Mounting the gas header

Attention!

All lines/piping must be mounted free of tension. The weight of all the components should be supported separately from the boiler so there is no force on the connections.

Attention!

During mounting of the gas header group it is very important that the position of the support beam as well as the support brackets of the headers allow for some play (tolerance) for a neat installation. After finishing the installation, the support beam and brackets can be tightened.

1. Mount the support beam(s) for the hydraulic and gas header group loosely between the legs of the L-stands.
2. Mount the support brackets for the gas header at nominal height. See also Figure 7.2.
3. Place the gas header(s) on the support brackets and fasten it (them) loosely with the U-bolts. Make sure that the connections for the corresponding connecting sets are at the upper side of the header(s).
4. Next mount the boilers on the frame. See chapter 10.

10. Mounting the boilers on the frame

1. Before mounting the boiler on the frame, ensure that the frame is level both horizontally and vertically. If necessary adjust with the adjusting bolts on the lower side of the frame (see Figure 10.1).
2. Hang the boilers on the frame.
3. Align the boilers with the L-stand in such a way that there is an exact 50 mm gap between the boilers.
4. Lock the suspension bracket with the locking strip to prevent the boiler from falling off the bracket (see drawing).
5. Make sure that the boiler is at the right position (near level). The boilers must hang backwards slightly ($1^\circ \pm 0.5^\circ$). If necessary, adjust with the adjusting bolts on the lower rear side of the back panel (see Figure 10.1). When the adjusting bolts are **not** sufficient, the space behind the bolts needs to be filled to achieve the correct position.

Attention!

The boiler must **never lean forward** in the mounted position.

6. Next mount the hydraulic group and connecting sets. See chapter 11.

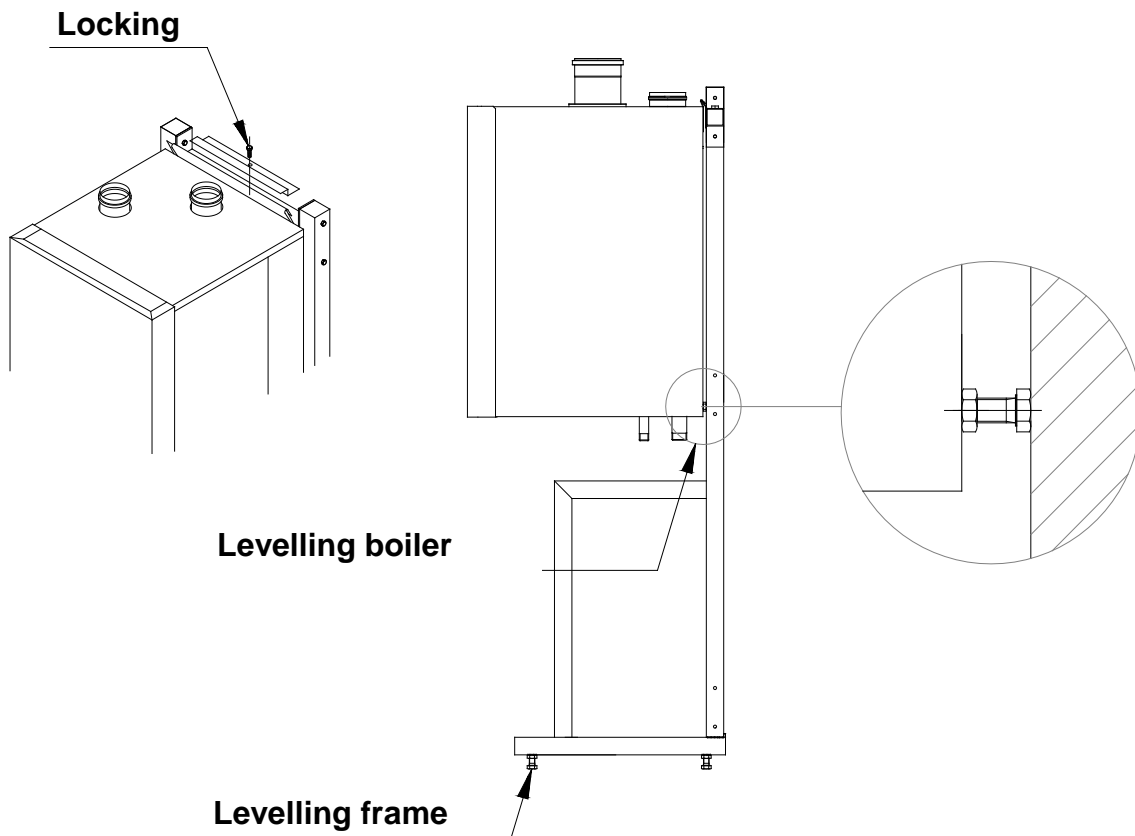

Figure 10.1 Mounting details

11. Mounting the hydraulic group and the connecting sets

After the boiler has been mounted on the frame, the hydraulic group and the connecting sets must be mounted.

Attention!

All lines/piping must be mounted free of tension. The weight of all the components should be supported separately from the boiler so there is no force on the connections.

Attention!

During mounting of the hydraulic and gas header group it is very important that the position of the support beam as well as the support brackets of the headers allow for some play (tolerance) for a neat installation. After finishing the installation, the support beam and brackets can be tightened.

1. Mount the support brackets for the return header at nominal height. See also Figure 7.2.
2. Place the return header(s) (bottom water header / blue) on the support brackets and fasten it (them) loosely with the U-bolts. Make sure that the connections for the corresponding connecting sets are at the back of the header.
3. Mount the connecting sets for the return header. See also Figure 7.3.

Attention!

An external pump (to be ordered separately) must be mounted between the return connecting set and the boiler. Required for this are:

- pump supplied with 2 flat-seal two-part couplings;
 - 1 flat-seal coupling for connection to boiler (inside thread / female thread)
 - 1 flat-seal coupling for connection to connecting set (outside thread / male thread)
- a. Fit the flat-seal couplings to the boiler and to the connecting set.
 - b. Mount the pump to the boiler; pay attention to its orientation.
 - c. Mount the connecting set to the pump; pay attention to its orientation.
 - d. Bend the flexible part of the return connecting set into a smooth bend.
 - e. Fit the connecting set to the return header (conical three-part coupling). Fit the loose part to the header and then fasten the coupling.
4. Mount the support brackets for the supply header. See also Figure 7.2.
 5. Place the supply header(s) (top water header / red) on the support brackets and fasten it (them) loosely with the U-bolts.
 6. Mount the connecting sets for the supply header. See also Figure 7.3.
The connecting set has a three-part coupling for the connection to the boiler.
 - a. Fit the loose part of the three-part coupling to the boiler.
 - b. Fit the connecting set to the coupling.
 - c. Fit the connecting set to the supply header (conical three-part coupling). Fit the loose part to the header and then fasten the coupling.
 7. Fit the gas connecting sets to the boiler and to the gas header.
 8. When all parts are mounted correctly and are free of tension, fasten all couplings, bolts and U-bolts.
 9. Next mount the low loss header. See chapter 12.

12. Mounting the low loss headers

After mounting the hydraulic and gas header group and the connecting sets to the boilers, the low loss header must be mounted to the supply and return headers.

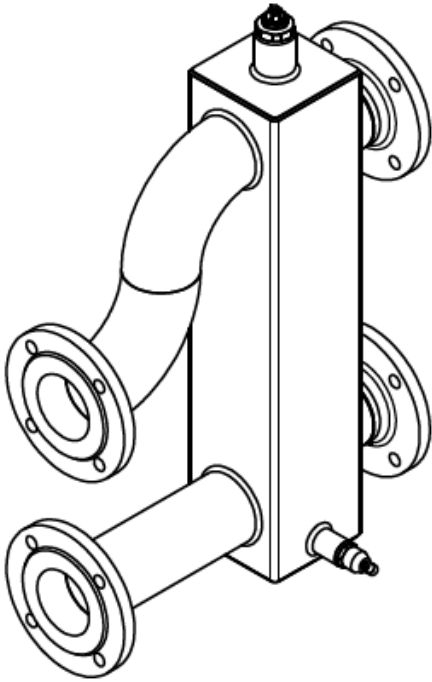

Figure 12.1 Low loss header

Depending on the configuration of the cascade setup, one of the following low loss headers can be mounted:

Type	Size	Used for	Article number	Size
DN 65	2,5"	Cascade installation up to 360 kW	E68.0300.501	120 x 120 x 3
DN 80	3"	Cascade installation 360 up to 540 kW	E68.0300.502	140 x 140 x 4
DN 100	4"	Cascade installation 540 to 930 kW	E68.0300.503	200 x 200 x 5

Table 12.1 Low loss header connection sizes

The low-loss header can be fitted on the right-hand side as well as on the left-hand side without making any alterations to the supplied parts. The gas connection can also be fitted on one of both sides, independent from the side chosen for the low loss header.

1. Mount the low loss header.
It can be mounted on the right-hand or the left-hand side of the supply and return headers, whatever the best place for connecting the headers to the heating installation.
2. Fit the supplied flanges on the opposite end of the supply and return headers in order to block those ends.
3. Fit the supplied seal cap on the opposite end of the gas header in order to block that end.

13. Determine managing and depending boilers

Before completing the mechanical installation it is important to decide which boiler will be the managing boiler.

Any of the boilers can be assigned as managing boiler; all the other boilers in the cascade configuration have to be assigned as depending boilers.

When the CH supply temperature is based on an outdoor sensor, only one outdoor sensor is needed. This sensor is connected to the managing boiler and calculates the CH setpoint for the cascade system.

A cascade system can be used with an DHW indirect tank. A DHW circulator and sensor must be connected to the managing boiler.

All boilers in the cascade system have to be assigned a unique address. This is done in the parameters of each boiler.

How to assign unique addresses to boilers and how to manage the parameters required for the cascade configuration is described in detail in the chapter(s) about Cascading in the Installation & Service Manual of the CB boiler series.

14. Complete the mechanical installation

After the previous instructions have been completed, the cascade configuration must be connected to the heating system and the mechanical installation of the cascade configuration must be completed with all other necessary parts and connections.

This may include:

- all valves
- non-return valves
- strainers
- air separators
- expansion vessel
- overflow

Attention!

The hydraulic piping of the Eco Heating Systems cascade systems already contains non-return valves underneath each boiler. When other hydraulic systems are used, non-return valves must be fitted in the return pipe of each boiler.

The Installation & Service Manual of the CB boiler series provides you with the necessary installation schemes and requirements to complete the installation.

In addition to the instructions from the Installation & Service Manual, it is imperative for the cascade configuration to:

- Complete all wiring of the boilers according to the boiler manual. For the system to work for cascade the communication busses must be parallel linked together.

Attention!

Link all connections 10 to 10 and all connections 11 to 11, do not mix these.

Link connections 10 of the dependent boilers to 20 of the managing boiler, and connections 11 of the dependent boilers to 21 of the managing boiler.

For more information refer to the chapters on Electrical Installation and Cascade in the Installation & Service Manual of the CB boiler series.

- If no expansion vessel or overflow is fitted to the T-connection of the supply connecting set and/or return connecting set, the T-connection(s) must be blocked by fitting a cap or stopper on the T-connection(s) in question.

15. Mount the flue gas and air supply systems

After the cascade installation has been connected to the heating installation, the flue gas and air supply systems must be mounted in compliance with the applicable standards and regulations and in accordance with the instructions from the Installation & Service Manual of the CB boiler series.

15.1 Individual flue systems

The individual flue systems must be mounted in compliance with the applicable standard and in accordance with the instructions from the Installation & Service Manual of the CB boiler series (“**Flue gas and air supply system**”).

For each boiler, the combined resistance of the individual flue gas and air inlet pipe can be calculated and checked with the maximum resistance allowed.

For resistance tables and example calculations we refer to the aforementioned chapter in the boiler manual.

15.2 Common flue system

A common flue system must be designed in accordance with EN 13384-2 “Chimney – Thermal and fluid dynamic calculation methods – Part 2: Chimneys serving more than one heating appliance.”

Eco Heating Systems can advise you on the software to be used for doing these calculations. Do not attempt to design common flue systems without the appropriate software and training.

16. Set parameters

Before commissioning the cascade installation, several parameters have to be changed in order to have the boilers operate in unison as a cascade configuration.

These parameters can be programmed on each boiler itself in the display of the boiler (so without the use of an external computer).

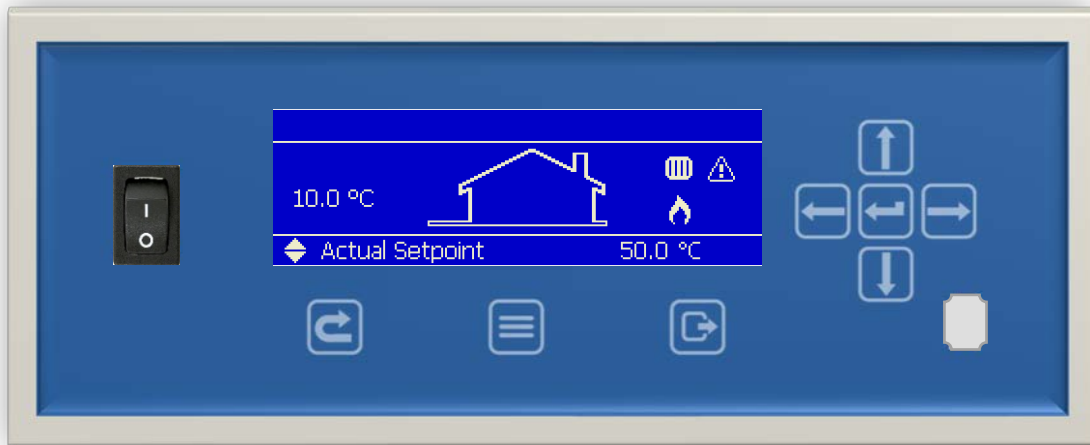

Figure 16.1 Boiler display

One of the boilers has been assigned as managing boiler; all the other boilers in the cascade configuration have been assigned as depending boilers (see chapter 13).

These depending boilers in the cascade system have to be assigned a unique address. This is set in the parameters of each boiler.

How to assign unique addresses to boilers and how to manage the parameters required for the cascade configuration is described in detail in the chapter(s) about Cascading in the Installation & Service Manual of the CB boiler series.

Attention!

Changes in parameters may only be carried out by a skilled installation/service engineer, who has had specific training for setting up the CB boilers. He will be able to check whether the installation functions correctly after the parameter change has been done.

17. Commissioning the cascade configuration

To complete the cascade configuration, the installation must be commissioned. Commissioning is described in detail in the relevant chapter(s) of the Installation & Service Manual of the CB boiler series.

After commissioning the total cascade configuration will act as one single boiler, switching boilers on and off, depending on the total load necessary to adjust and keep the supply temperature at the set value.

18. Accessories

To complete your cascade configuration the following accessories are available:

	Sensors	Details	Article nr.	Remarks
1	Outside air temperature sensor	12kOhm@25°C	E04.016.306	Optional
2	External flow temperature sensor low loss header	10kOhm@25°C	E04.016.304	Required

Table 18.1 Accessories

19. References

19.1 List of figures

Figure 1.1 Typical cascade configuration	4
Figure 4.1 Dimensions front view	8
Figure 4.2 Dimensions: side views	9
Figure 5.1 Cascade parts and groups	11
Figure 6.1 Connecting sets	12
Figure 7.1 Parts hydraulic and gas header group	13
Figure 7.2 Headers support beam and support brackets	13
Figure 7.3 Headers and connecting sets	14
Figure 8.1 Frame elements.....	15
Figure 10.1 Mounting details	18
Figure 12.1 Low loss header	20
Figure 16.1 Boiler display	23

19.2 List of tables

Table 3.1 Cascade power calculation table based on CB boilers	7
Table 4.1 Dimensions CB cascade up to 360 kW	10
Table 4.2 Dimensions CB cascade 360 up to 540 kW	10
Table 4.3 Dimensions CB cascade 540 to 930 kW	10
Table 8.1 Frame elements per cascade set	16
Table 12.1 Low loss header connection sizes.....	20
Table 18.1 Accessories	24

20. Appendix A – Cascade Parts

The following drawings give an overview of parts used in a cascade configuration.

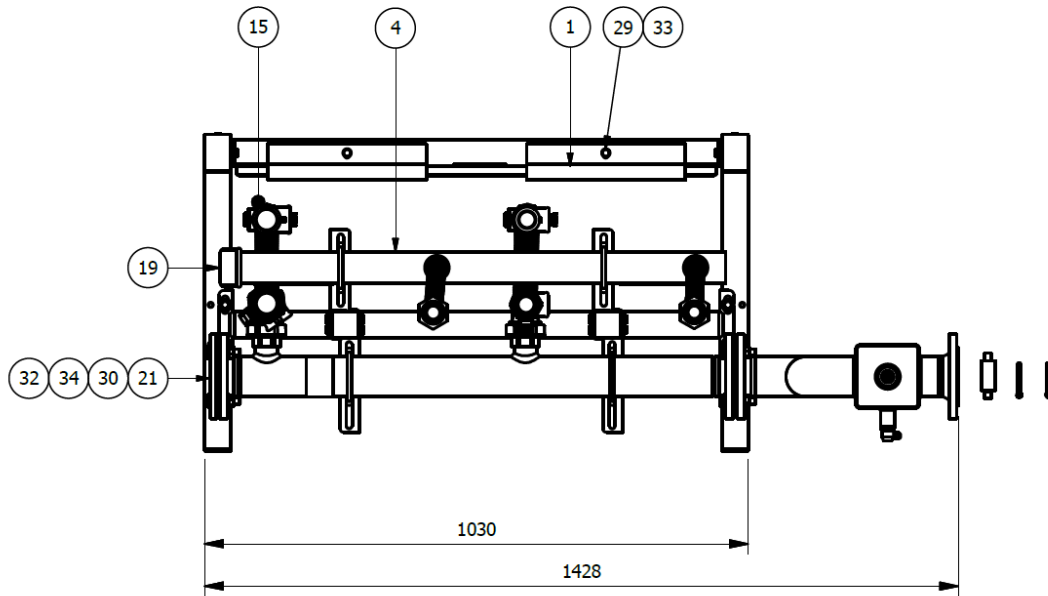

Top view

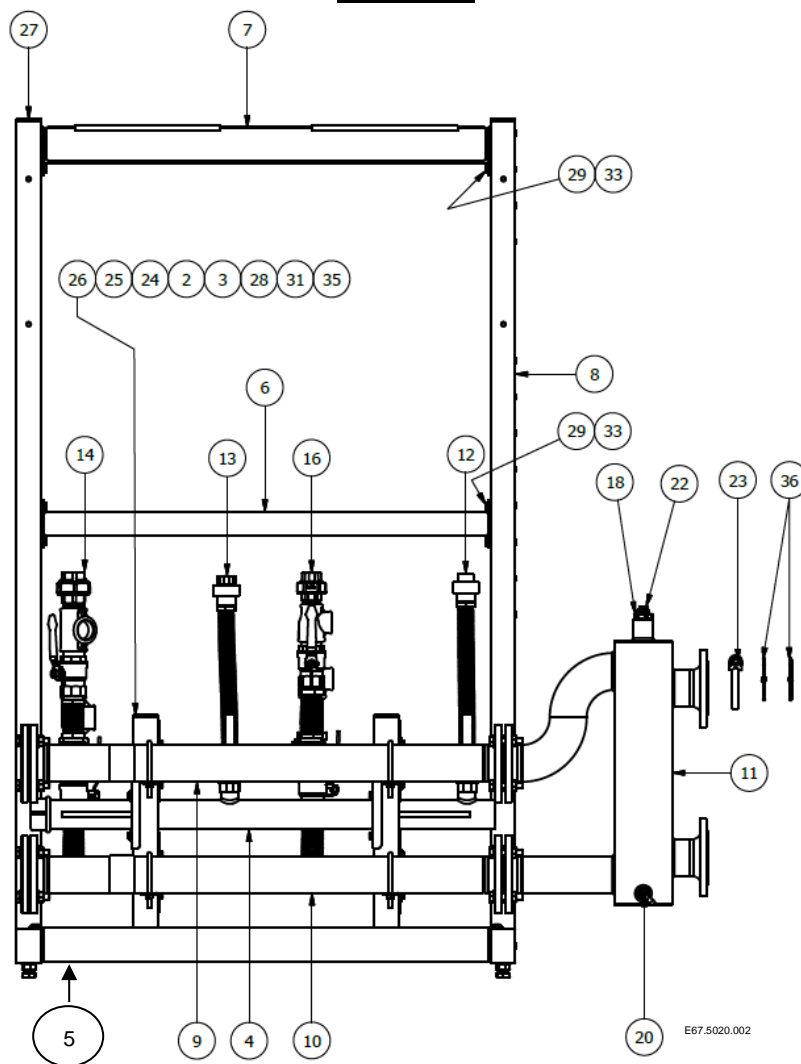

Front view

The exact amount for each part in the cascade configuration varies and depends on the cascade type and the number of boilers in the cascade set.

Furthermore, headers and connecting set couplings come in different sizes, depending on the cascade configuration (see Table 4.1, Table 4.2 and Table 4.3).

Part list

Nr in drawing	Part description	Remarks / variants
1	Locking strip Cascade	
2	Support bracket water header	
3	Support bracket gas header	
4	Gas Header	DN50 / DN80
5	Support beam	for mounting the support brackets
6	In-between beam	
7	Top beam	
8	L-stand	
9	Supply header	DN65 / DN80 / DN100
10	Return header	DN65 / DN80 / DN100
11	Low loss header	DN65 / DN80 / DN100
12	Gas connecting set ¾ "	
13	Gas connecting set 1"	
14	Supply connecting set R1¼	
15	Return connecting set R1¼	
16	Supply connecting set R1	
	Return connecting set R1	alternative to 15 – not in figure
18	Reducing ring	
19	Seal cap Rp2	DN50 / DN80 to block gas header
20	Drain tap G½	
21	Blind flange	DN65 / DN80 / DN100 to block water headers
22	Air vent	
23	External temperature sensor	
24	U-bolt M8 x 50-61 2"	
25	U-bolt M8 x 71-77 2½	
26	Square seal plug 50 x 50	
27	Rectangular seal plug 70 x 50	
28	Hexagonal bolt M8x16 DIN933	
29	Hexagonal bolt M8x25 DIN933	
30	Hexagonal bolt M12x60 DIN933	
31	Hexagonal nut M8 DIN934	
32	Hexagonal nut M12 DIN934	
33	Flat washer M8 DIN 125-1A	
34	Flat washer M12 DIN 125-1A	
35	Flat washer large M8x24 DIN9021	
36	Tyrap 385 x 4.8 mm	for keeping together loose wires and cables

Your distributor:

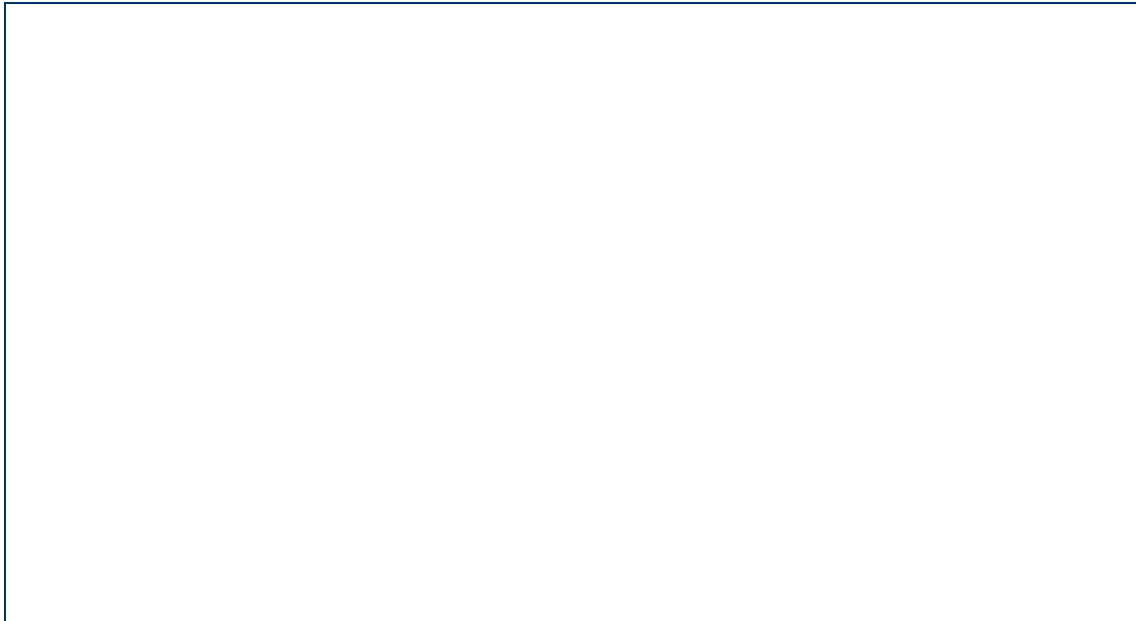

Eco Heating Systems Groningen B.V.

P.O. Box 5145 9700 GC Groningen
Rigaweg 10 9723 TH Groningen

The Netherlands

T +31 (0)50 5470470

E sales@ecohts.nl

I www.ecohts.nl

