



# USER MANUAL (1 of 2)

## INSTALLATION and STARTUP GUIDE

# Benchmark<sup>®</sup> Platinum Series Boilers

Natural Gas, Propane Gas, or Dual Fuel Fired Modulating, Condensing Boilers

750, 1000, 1500, 2000, 2500, and 3000 MBH Boilers



**SEE ALSO:** *Benchmark PLATINUM Operation, Service and Maintenance Guide (GF-201)*

**APPLIES TO MODELS:**

**Natural Gas:**

- BMK 750
- BMK 1000
- BMK 1500
- BMK 2000
- BMK 2500
- BMK 3000

**Dual-Fuel (NG/P):**

- BMK 1500DF
- BMK 2000DF
- BMK 2500DF
- BMK 3000DF

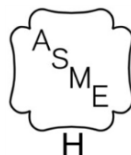
**Propane:**

- BMK 750P
- BMK 1000P
- BMK 1500P
- BMK 2000P
- BMK 2500P
- BMK 3000P

**Applies to Serial Numbers:**  
G-17-2400 and above.

*Latest Update: 11/29/2017*

**Technical Support**  
1-800-526-0288  
(Mon-Fri, 8am-5pm EST)  
[www.aerco.com](http://www.aerco.com)



**DISCLAIMER:**

The information contained in this manual is subject to change without notice from AERCO International, Inc. AERCO makes no warranty of any kind with respect to this material, including, but not limited to, implied warranties of merchantability and fitness for a particular application. AERCO International is not liable for errors appearing in this manual, nor for incidental or consequential damages occurring in connection with the furnishing, performance, or use of these materials

# TABLE OF CONTENTS

<b>FOREWORD .....</b>	<b>5</b>
<b>SECTION 1: SAFETY PRECAUTIONS .....</b>	<b>9</b>
1.1 WARNINGS & CAUTIONS.....	9
1.2 EMERGENCY SHUTDOWN .....	10
1.3 PROLONGED SHUTDOWN .....	10
1.4 IMPORTANT – FOR MASSACHUSETTS INSTALLATIONS.....	11
<b>SECTION 2: INSTALLATION .....</b>	<b>13</b>
2.1 INTRODUCTION.....	13
2.2 RECEIVING THE UNIT .....	13
2.3 UNPACKING.....	13
2.4 SITE PREPARATION .....	14
2.4.1 Installation Clearances .....	14
2.4.2 Setting the Unit .....	17
2.5 LIFTING PROVISIONS .....	19
2.5.1 BMK 750 – 1000 lifting Provisions.....	19
2.5.2 BMK 1500 – 3000 Lifting Provisions .....	20
2.6 SUPPLY AND RETURN PIPING.....	21
2.6.1 BMK 750 – 1000 Supply and Return Piping.....	21
2.6.2 BMK 1500 – 3000 Supply and Return Piping.....	21
2.6.3 Dual Inlet Return Piping .....	22
2.7 PRESSURE RELIEF VALVE INSTALLATION .....	23
2.8 CONDENSATE DRAIN AND PIPING.....	24
2.9 GAS SUPPLY PIPING .....	26
2.9.1 Gas Supply Specifications .....	27
2.9.2 Manual Gas Shutoff Valve .....	27
2.9.3 External Gas Supply Regulator .....	28
2.10 AC ELECTRICAL POWER WIRING.....	30
2.10.1 Electrical Power Requirements .....	30
2.10.2 Power Box Locations .....	32
2.10.3 Electrical Power Box Internal Components.....	33
2.11 FIELD CONTROL WIRING .....	35
2.11.1 Outdoor Air & Air Sensor Common.....	36
2.11.2 AIR TEMP SENSOR .....	37
2.11.3 O <sub>2</sub> SENSOR (+ & -) .....	37
2.11.4 SPARK SIGNAL (+ & -).....	37
2.11.5 ANALOG IN .....	37
2.11.6 VALVE FEEDBACK.....	37
2.11.7 SHIELD (SHLD & SHLD).....	38
2.11.8 ANALOG OUT.....	38
2.11.9 RS485 Comm (+, GND, & -).....	38
2.11.10 RS232 Comm (TxD & RxD).....	38
2.11.11 VFD/Blower (0-10 & AGND) .....	38
2.11.12 Interlocks.....	39

**CONTENTS**

2.11.13 Fault Relay (NC, COM, & NO) ..... 39

2.11.14 Auxiliary Relay Contacts (NC, COM, & NO) ..... 39

2.12 FLUE GAS VENT INSTALLATION ..... 40

2.12.1 MASSACHUSETTS INSTALLATIONS ..... 40

2.13 COMBUSTION AIR ..... 41

2.13.1 DUCTED COMBUSTION AIR ..... 41

2.14 BENCHMARK PUMP RELAY ..... 42

2.15 SEQUENCING ISOLATION VALVE INSTALLATION ..... 43

**SECTION 3: START SEQUENCE ..... 45**

3.1 INTRODUCTION ..... 45

3.2 START SEQUENCE ..... 45

3.3 START/STOP LEVELS ..... 51

3.4 START/STOP LEVELS – AIR/FUEL & ENERGY INPUT ..... 52

3.4.1 BMK 750/1000 Air/Fuel Valve Position and Energy Input ..... 52

3.4.2 BMK 1500 Air/Fuel Valve Position and Energy Input ..... 53

3.4.3 BMK 2000 Air/Fuel Valve Position and Energy Input ..... 54

3.4.4 BMK 2500 Air/Fuel Valve Position and Energy Input ..... 55

3.4.5 BMK 3000 Air/Fuel Valve Position and Energy Input ..... 56

**SECTION 4: INITIAL START-UP ..... 57**

4.1 INITIAL START-UP REQUIREMENTS ..... 57

4.2 TOOLS & INSTRUMENTS FOR COMBUSTION CALIBRATION ..... 57

4.2.1 Required Tools & Instrumentation ..... 57

4.2.2 Installing Gas Supply Manometer ..... 58

4.2.3 Accessing the Analyzer Probe Port ..... 60

4.3 FUEL TYPES AND COMBUSTION CALIBRATION ..... 61

4.4 COMBUSTION CALIBRATION ..... 62

4.4.1 NATURAL GAS Combustion Calibration ..... 63

4.4.2 PROPANE GAS COMBUSTION CALIBRATION ..... 67

4.5 REASSEMBLY ..... 71

4.6 DUAL FUEL SWITCHOVER ..... 71

4.6.1 Switchover from NATURAL GAS to PROPANE ..... 72

4.6.2 Switchover from PROPANE to NATURAL GAS ..... 73

4.7 OVER-TEMPERATURE LIMIT SWITCHES ..... 74

4.7.1 Digital Alarm Switch Checks and Adjustments ..... 75

**SECTION 5: SAFETY DEVICE TESTING ..... 77**

5.1 TESTING OF SAFETY DEVICES ..... 77

5.2 LOW GAS PRESSURE TEST ..... 78

5.2.1 LOW GAS PRESSURE TEST: BMK 750 – 2500 ..... 78

5.2.2 LOW GAS PRESSURE TEST: BMK 3000 Only ..... 80

5.3 HIGH GAS PRESSURE TEST ..... 82

5.3.1 HIGH GAS PRESSURE TEST: BMK 750 – 2500 ..... 82

5.3.2 HIGH GAS PRESSURE TEST: BMK 3000 Only ..... 84

5.4 LOW WATER LEVEL FAULT TEST ..... 86

5.5 WATER TEMPERATURE FAULT TEST ..... 87

**CONTENTS**

5.6 INTERLOCK TESTS .....89  
 5.6.1 Remote Interlock Test .....89  
 5.6.2 Delayed Interlock Test.....89  
 5.7 FLAME FAULT TEST .....90  
 5.8 AIR FLOW FAULT TESTS - BLOWER PROOF & BLOCKED INLET SWITCHES .....91  
 5.8.1 Blower Proof Switch Test .....91  
 5.8.2 Blocked Inlet Switch Test.....93  
 5.9 SSOV PROOF OF CLOSURE SWITCH CHECK .....94  
 5.10 PURGE SWITCH OPEN DURING PURGE .....94  
 5.11 IGNITION SWITCH OPEN DURING IGNITION.....97  
 5.12 SAFETY PRESSURE RELIEF VALVE TEST .....97  
**SECTION 6: BOILER SEQUENCING TECHNOLOGY .....99**  
 6.1 INTRODUCTION.....99  
 6.1.1 INSTALLATION NOTES.....100  
 6.2 AERCO BST QUICK START CHART .....100  
 6.3 BST IMPLEMENTATION INSTRUCTION .....101  
 6.3.1 OPTION 1 - CONSTANT SETPOINT WITH DIRECT WIRED HEADER SENSOR.....101  
 6.3.2 OPTION 2 - CONSTANT SETPOINT WITH MODBUS WIRED HEADER SENSOR .....102  
 6.3.3 OPTION 3 - OUTDOOR RESET WITH DIRECT WIRED HEADER SENSOR AND DIRECT WIRED  
 OUTDOOR SENSOR.....103  
 6.3.4 OPTION 4 - OUTDOOR RESET WITH MODBUS HEADER SENSOR AND MODBUS OUTDOOR SENSOR  
 .....105  
 6.3.5 OPTION 5 - REMOTE SETPOINT WITH DIRECT WIRED HEADER SENSOR AND 4-20MA SETPOINT  
 DRIVE .....107  
 6.3.6 OPTION 6 - REMOTE SETPOINT WITH DIRECT WIRED HEADER SENSOR AND MODBUS SETPOINT  
 DRIVE .....109  
 6.3.7 OPTION 7 - REMOTE SETPOINT WITH MODBUS HEADER SENSOR AND 4-20MA SETPOINT DRIVE  
 .....111  
 6.3.8 Option 8 - Remote Setpoint with MODBUS Header Sensor AND MODBUS Setpoint Drive.....113  
**SECTION 7: ONAER SETUP.....115**  
 7.1 INTRODUCTION.....115  
 7.1.1 Connecting the Ethernet Cable .....115  
 7.1.2 Confirming the Ethernet Connection .....117  
 7.1.3 Confirm Ethernet DHCP Configuration.....117  
**APPENDIX A: DIMENSIONAL AND CLEARANCE DRAWINGS .....119**

# FOREWORD

The AERCO Benchmark (BMK) 750, 1000, 1500, 2000, 2500, and 3000 natural gas and propane fueled boilers are modulating and condensing units. They represent a true industry advance that meets the needs of today's energy and environmental concerns. Designed for application in any closed loop hydronic system, the Benchmark's modulating capability relates energy input directly to fluctuating system loads. These BMK models provide extremely high efficiency operation and are ideally suited for modern low temperature, as well as, conventional heating systems.

## IMPORTANT!

Unless otherwise specified all descriptions provided in this document apply to the Benchmark Platinum Series of boiler.

The Benchmark models operate within the input and output ranges listed below. All measurements apply to both natural gas and propane models, unless otherwise specified.

Benchmark Platinum Boiler Intake and Output Ranges				
MODEL	INPUT RANGE (BTU/HR.)		OUTPUT RANGE (BTU/HR.)	
	MINIMUM	MAXIMUM	MINIMUM	MAXIMUM
<b>BMK 750</b>	50,000 (14.6 kW)	750,000 (220 kW)	47,750 (14.0 kW)	716,250 (210 kW)
<b>BMK 1000</b>	50,000 (14.6 kW)	1,000,000 (293 kW)	48,300 (14.2 kW)	968,000 (284 kW)
<b>BMK 1500</b>	75,000 (22 kW)	1,500,000 (440 kW)	64,500 (18.9 kW)	1,395,000 (409 kW)
<b>BMK 2000</b>	100,000 (29.3 kW)	2,000,000 (586 kW)	86,000 (25.2 kW)	1,860,000 (545 kW)
<b>BMK 2500</b>	167,000 (48.9 kW)	2,500,000 (732 kW)	144,000 (42.2 kW)	2,395,000 (702 kW)
<b>BMK 3000</b>	200,000 (58.6 kW)	3,000,000 (879 kW)	174,000 (51.0 kW)	2,874,000 (842 kW)

The output of the boiler is a function of the unit's firing rate (valve position) and return water temperature.

When installed and operated in accordance with this Instruction Manual, these boilers comply with the NO<sub>x</sub> emission standards outlined in: **South Coast Air Quality Management District (SCAQMD), Rule 1146.2**. In addition, the BMK 750 & 1000 comply with the **Bay Area Air Quality Management District regulation 9, Rule 7**.

Whether used in singular or modular arrangements, the BMK boilers offer the maximum venting flexibility with minimum installation space requirements. These boilers are Category II and IV, positive pressure appliances. Single and/or multiple breeched units are capable of operation in the following vent configurations:

- **Room Combustion Air:**
  - Vertical Discharge
  - Horizontal Discharge
- **Ducted Combustion Air:**
  - Vertical Discharge
  - Horizontal Discharge

These boilers are capable of being vented utilizing Polypropylene and AL29-4C vent systems. In addition, the BMK 750 & 1000 models are also approved for PVC and CPVC, vent systems.

FORWARD

The Benchmark's advanced electronics are available in several selectable modes of operation offering the most efficient operating methods and energy management system integration.

<b>AERCO Technical Terminology Meanings</b>	
<b>TERMINOLOGY</b>	<b>MEANING</b>
A (Amp)	Ampere
ACS	AERCO Control System, AERCO's boiler management systems
ADDR	Address
AGND	Analog Ground
ALRM	Alarm
ANSI	American National Standards Institute,
ASME	American Society of Mechanical Engineers
AUX	Auxiliary
BAS	Building Automation System, often used interchangeably with EMS (see below)
Baud Rate	Symbol rate, or simply the number of distinct symbol changes (signaling events) transmitted per second. It is not equal to bits per second, unless each symbol is 1 bit long.
BMK (Benchmark)	AERCO's Benchmark series boilers
BMS or BMS II	AERCO Boiler Management Systems
BLDG (Bldg)	Building
BST	AERCO on-board Boiler Sequencing Technology
BTU	British Thermal Unit. A unit of energy approximately equal to the heat required to raise 1 pound (0.45 kg) of water 1°F (0.55 °C)
BTU/HR	BTUs per Hour (1 BTU/hr = 0.29 W)
CCP	Combination Control Panel
CCS	Combination Control System
C-More Controller	A control system developed by AERCO and currently used in all Benchmark, Innovation and KC1000 Series product lines.
CFH	Cubic Feet per Hour (1 CFH = 0.028 m <sup>3</sup> /hr)
CO	Carbon Monoxide
COMM (Comm)	Communication
Cal.	Calibration
CNTL	Control
CPU	Central Processing Unit
DBB	Double Block and Bleed, a gas trains containing 2 Safety Shutoff Valves (SSOVs) and a solenoid operated vent valve.
DIP	Dual In-Line Package, a type of switch
ECU	Electronic Control Unit (O <sub>2</sub> sensor)
EMS	Energy Management System; often used interchangeably with BAS
FM	Factory Mutual. Used to define boiler gas trains.

<b>AERCO Technical Terminology Meanings</b>	
<b>TERMINOLOGY</b>	<b>MEANING</b>
GF-xxxx	Gas Fired (an AERCO document numbering system)
GND	Ground
HDR	Header
Hex	Hexadecimal Number (0 – 9, A – F)
HP	Horse Power
HX	Heat Exchanger
Hz	Hertz (Cycles Per Second)
I.D.	Inside Diameter
IGN	Ignition
IGST Board	Ignition/Stepper Board, contained in C-More Controller
INTLK (INTL'K)	Interlock
I/O	Input/Output
I/O Box	Input/Output (I/O) Box currently used on Benchmark, Innovation and KC1000 Series products
IP	Internet Protocol
ISO	International Organization for Standardization
Lbs.	Pounds (1 lb = 0.45 kg)
LED	Light Emitting Diode
LN	Low Nitrogen Oxide
MA (mA)	Milliampere (1 thousand <sup>th</sup> of an ampere)
MAX (Max)	Maximum
MBH	1000 BTUs per Hour
MIN (Min)	Minimum
Modbus®	A serial, half-duplex data transmission protocol developed by AEG Modicon
NC (N.C.)	Normally Closed
NO (N.O.)	Normally Open
NO <sub>x</sub>	Nitrogen Oxide
NPT	National Pipe Thread
O <sub>2</sub>	Oxygen
O.D.	Outside Diameter
OMM & O&M	Operation and Maintenance Manual
onAER	AERCO's on-line remote monitoring system
PCB	Printed Circuit Board
PMC Board	Primary Micro-Controller (PMC) board, contained in the C-More Controller
P/N	Part Number
POC	Proof of Closure



<b>AERCO Technical Terminology Meanings</b>	
<b>TERMINOLOGY</b>	<b>MEANING</b>
PPM	Parts per Million
PSI	Pounds per Square Inch (1 PSI = 6.89 kPa)
PTP	Point-to-Point (usually over RS232 networks)
P&T	Pressure and Temperature
ProtoNode	Hardware interface between BAS and a boiler or water heater
PVC	Poly Vinyl Chloride, a common synthetic plastic
PWM	Pulse Width Modulation
REF (Ref)	Reference
RES.	Resistive
RS232 (or EIA-232)	A standard for serial, full-duplex (FDX) transmission of data based on the RS232 Standard
RS422 (or EIA-422)	A standard for serial, full-duplex (FDX) transmission of data based on the RS422 Standard
RS485 (or EIA-485)	A standard for serial, half-duplex (HDX) transmission of data based on the RS485 Standard
RTN (Rtn)	Return
SETPT (Setpt)	Setpoint Temperature
SHLD (Shld)	Shield
SPDT	Single Pole Double Throw, a type of switch
SSOV	Safety Shut Off Valve
TEMP (Temp)	Temperature
Terminating Resistor	A resistor placed at each end of a daisy-chain or multi-drop network in order to prevent reflections that may cause invalid data in the communication
Tip-N-Tell	A device that indicates if a package was tipped during shipping
UL	A business that tests and validates products
VAC	Volts, Alternating Current
VDC	Volts, Direct Current
VFD	Vacuum Fluorescent Display, also Variable Frequency Drive
W	Watt
W.C.	Water Column, a unit of pressure (1 W.C. = 249 Pa)
µA	Micro amp (1 million <sup>th</sup> of an ampere)



## SECTION 1: SAFETY PRECAUTIONS

### 1.1 WARNINGS & CAUTIONS

Installers and operating personnel **MUST**, at all times, observe all safety regulations. The following warnings and cautions are general and must be given the same attention as specific precautions included in these instructions. In addition to all the requirements included in this AERCO Instruction Manual, the installation of units **MUST** conform with local building codes, or, in the absence of local codes, ANSI Z223.1 (National Fuel Gas Code Publication No. NFPA-54) for gas-fired boilers and ANSI/NFPASB for LP gas-fired boilers. Where applicable, the equipment shall be installed in accordance with the current Installation Code for Gas Burning Appliances and Equipment, CSA B149.1, and applicable Provincial regulations for the class; which should be carefully followed in all cases. Authorities having jurisdiction should be consulted before installations are made.

See section 1.4 for important information regarding installation of units within the Commonwealth of Massachusetts.

#### IMPORTANT!

This Instruction Manual is an integral part of the product and must be maintained in legible condition. It must be given to the user by the installer and kept in a safe place for future reference.

#### WARNING!

- Do not use matches, candles, flames, or other sources of ignition to check for gas leaks.
- Fluids under pressure may cause injury to personnel or damage to equipment when released. Be sure to shut off all incoming and outgoing water shutoff valves. Carefully decrease all trapped pressures to zero before performing maintenance.
- Before attempting to perform any maintenance on the unit, shut off all gas and electrical inputs to the unit.
- The exhaust vent pipe of the unit may operate under a positive pressure and therefore must be completely sealed to prevent leakage of combustion products into living spaces.
- Electrical voltages up to 120 VAC (BMK 750 – 2000) and 208 or 460 VAC (BMK 2500/3000) may be used in this equipment. Therefore the cover on the unit's power box (located behind the front panel door) must be installed at all times, except during maintenance and servicing.
- A single-pole (120 VAC units) or three-pole (220 VAC or higher units) switch must be installed on the electrical supply line of the unit. The switch must be installed in an easily accessible position to quickly and safely disconnect electrical service. Do not affix switch to unit sheet metal enclosures.

**CAUTION!**

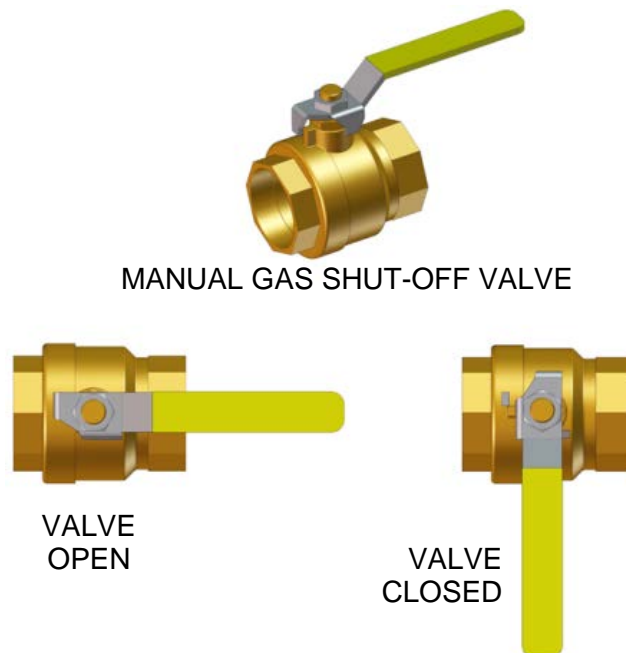
- Many soaps used for gas pipe leak testing are corrosive to metals. The piping must be rinsed thoroughly with clean water after leak checks have been completed.
- DO NOT use this boiler if any part has been under water. Call a qualified service technician to inspect and replace any part that has been under water.

**1.2 EMERGENCY SHUTDOWN**

If overheating occurs or the gas supply fails to shut off, close the manual gas shutoff valve (Figure 1-1) located external to the unit.

**NOTE:**

The Installer must identify and indicate the location of the emergency shutdown manual gas valve to operating personnel.



**Figure 1-1: Manual Gas Shutoff Valve**

**1.3 PROLONGED SHUTDOWN**

After prolonged shutdown, it is recommended that the initial startup procedures in Section 4 and the safety device test procedures in Section 5 be performed to verify that all system-operating parameters are correct. If there is an emergency, turn off the electrical power supply to the AERCO boiler and close the manual gas valve located upstream from the unit. The installer must identify the emergency shut-off device.

## 1.4 IMPORTANT – FOR MASSACHUSETTS INSTALLATIONS

### Requirements for Massachusetts Installations

Boiler Installations within the Commonwealth of Massachusetts must conform to the following requirements:

- Boiler must be installed by a plumber or a gas fitter who is licensed within the Commonwealth of Massachusetts.
- Prior to unit operation, the complete gas train and all connections must be leak tested using a non-corrosive soap.
- The vent termination must be located a minimum of 4 feet above grade level. If side-wall venting is used, the installation must conform to the following requirements **extracted from 248 CMR 5.08 (2)**:

(a) For all side wall horizontally vented gas fueled equipment installed in every dwelling, building or structure used in whole or in part for residential purposes, including those owned or operated by the Commonwealth and where the side wall exhaust vent termination is less than seven (7) feet above finished grade in the area of the venting, including but not limited to decks and porches, the following requirements shall be satisfied:

**1. INSTALLATION OF CARBON MONOXIDE DETECTORS:** At the time of installation of the side wall horizontal vented gas fueled equipment, the installing plumber or gasfitter shall observe that a hard wired carbon monoxide detector with an alarm and battery back-up is installed on the floor level where the gas equipment is to be installed. In addition, the installing plumber or gasfitter shall observe that a battery operated or hard wired carbon monoxide detector with an alarm is installed on each additional level of the dwelling, building or structure served by the side wall horizontal vented gas fueled equipment. It shall be the responsibility of the property owner to secure the services of qualified licensed professionals for the installation of hard wired carbon monoxide detectors.

**a.** In the event that the side wall horizontally vented gas fueled equipment is installed in a crawl space or an attic, the hard wired carbon monoxide detector with alarm and battery back-up may be installed on the next adjacent floor level.

**b.** In the event that the requirements of this subdivision can not be met at the time of completion of installation, the owner shall have a period of thirty (30) days to comply with the above requirements; provided, however, that during said thirty (30) day period, a battery operated carbon monoxide detector with an alarm shall be installed.

**2. APPROVED CARBON MONOXIDE DETECTORS:** Each carbon monoxide detector as required in accordance with the above provisions shall comply with NFPA 720 and be ANSI/UL 2034 listed and IAS certified.

**3. SIGNAGE:** A metal or plastic identification plate shall be permanently mounted to the exterior of the building at a minimum height of eight (8) feet above grade directly in line with the exhaust vent terminal for the horizontally vented gas fueled heating appliance or equipment. The sign shall read, in print size no less than one-half (1/2) inch in size, "**GAS VENT DIRECTLY BELOW. KEEP CLEAR OF ALL OBSTRUCTIONS**". (Continued)

**Requirements for Massachusetts Installations**

**4. INSPECTION:** The state or local gas inspector of the side wall horizontally vented gas fueled equipment shall not approve the installation unless, upon inspection, the inspector observes carbon monoxide detectors and signage installed in accordance with the provisions of 248 CMR 5.08(2)(a)1 through 4.

(b) **EXEMPTIONS:** The following equipment is exempt from 248 CMR 5.08(2)(a)1 through 4:

1. The equipment listed in Section 10 entitled "Equipment Not Required To Be Vented" in the most current edition of NFPA 54 as adopted by the Board; and
2. Product Approved side wall horizontally vented gas fueled equipment installed in a room or structure separate from the dwelling, building or structure used in whole or in part for residential purposes.

(c) **MANUFACTURER REQUIREMENTS - GAS EQUIPMENT VENTING SYSTEM PROVIDED.** When the manufacturer of Product Approved side wall horizontally vented gas equipment provides a venting system design or venting system components with the equipment, the instructions provided by the manufacturer for installation of the equipment and the venting system shall include:

1. Detailed instructions for the installation of the venting system design or the venting system components; and
2. A complete parts list for the venting system design or venting system.

(d) **MANUFACTURER REQUIREMENTS - GAS EQUIPMENT VENTING SYSTEM NOT PROVIDED.** When the manufacturer of a Product Approved side wall horizontally vented gas fueled equipment does not provide the parts for venting the flue gases, but identifies "special venting systems", the following requirements shall be satisfied by the manufacturer:

1. The referenced "special venting system" instructions shall be included with the appliance or equipment installation instructions; and
2. The "special venting systems" shall be Product Approved by the Board, and the instructions for that system shall include a parts list and detailed installation instructions.

(e) A copy of all installation instructions for all Product Approved side wall horizontally vented gas fueled equipment, all venting instructions, all parts lists for venting instructions, and/or all venting design instructions shall remain with the appliance or equipment at the completion of the installation.

.....[End of Extracted Information From 248 CMR 5.08 (2)].....

## SECTION 2: INSTALLATION

### 2.1 INTRODUCTION

This Section provides the descriptions and procedures necessary to unpack, inspect and install the AERCO Benchmark Platinum Boilers, models 750, 1000, 1500, 2000, 2500 and 3000.

### 2.2 RECEIVING THE UNIT

Each Benchmark Boiler System is shipped as a single crated unit. The shipping weight for these BMK models is approximately as follows:

- **BMK 750:** 1100 lbs. (499 kg)
- **BMK 1000:** 1200 lbs. (544 kg)
- **BMK 1500/2000:** 1800 lbs. (817 kg).
- **BMK 2500/3000:** 2200 lbs. (1000 kg)

The unit must be moved with the proper rigging equipment for safety and to avoid equipment damage. The unit should be completely inspected for evidence of shipping damage and shipment completeness at the time of receipt from the carrier and before the bill of lading is signed.

#### CAUTION!

While packaged in the shipping container, the unit must be moved by pallet jack or forklift from the FRONT ONLY.

#### NOTE:

AERCO is not responsible for lost or damaged freight. Each unit has a Tip-N-Tell indicator on the outside of the crate. This indicates if the unit has been turned on its side during shipment. If the Tip-N-Tell indicator is tripped, do not sign for the shipment. Note the information on the carrier's paperwork and request a freight claim and inspection by a claims adjuster before proceeding. Any other visual damage to the packaging materials should also be made clear to the delivering carrier.

### 2.3 UNPACKING

Carefully unpack the unit taking care not to damage the unit enclosure when cutting away packaging materials

After unpacking, make a close inspection of the unit to ensure that there is no evidence of damage not indicated by the Tip-N-Tell indicator. The freight carrier should be notified immediately if any damage is detected.

The following accessories come standard with each unit and are either packed separately within the unit's shipping container or are factory installed on the unit:

- Pressure/Temperature Gauge
- ASME Pressure Relief Valve
- Condensate Drain Trap (P/N **24441**)
- A 1 " or 2" Natural Gas Supply Shutoff Valve, and a Propane Shutoff Valve on Propane and Dual Fuel units

## SECTION 2 – INSTALLATION

When optional accessories are ordered, they may be packed within the unit's shipping container, factory installed on the unit, or packed and shipped in a separate container. Any standard or optional accessories shipped loose should be identified and stored in a safe place until ready for installation or use.

## 2.4 SITE PREPARATION

Ensure that the site selected for installation of the Benchmark Platinum Boiler includes:

- Access to AC input power specified in Section 2.10.1.
- Access to a natural gas or propane gas with minimum pressure specified in Section 2.9.1.

### 2.4.1 Installation Clearances

All Benchmark models are the same height, but vary in depth according to model pairs; 750/1000, 1500/2000, and 2500/3000. The unit must be installed with the prescribed clearances for service as shown in Figure 2-1a, 2-1b and 2-1c. The minimum clearance dimensions, required by AERCO, are listed below for all models. However, if Local Building Codes require additional clearances, these codes shall supersede AERCO's requirements. The **minimum acceptable clearances** required are as follows:

- Sides: 24 inches (61 cm)
- Front: 24 inches (61 cm)
- Rear: 24 inches (61 cm)
- Top: 18 inches (45.7 cm)

All gas piping, water piping and electrical conduit or cable must be arranged so that they do not interfere with the removal of any panels, or inhibit service or maintenance of the unit.

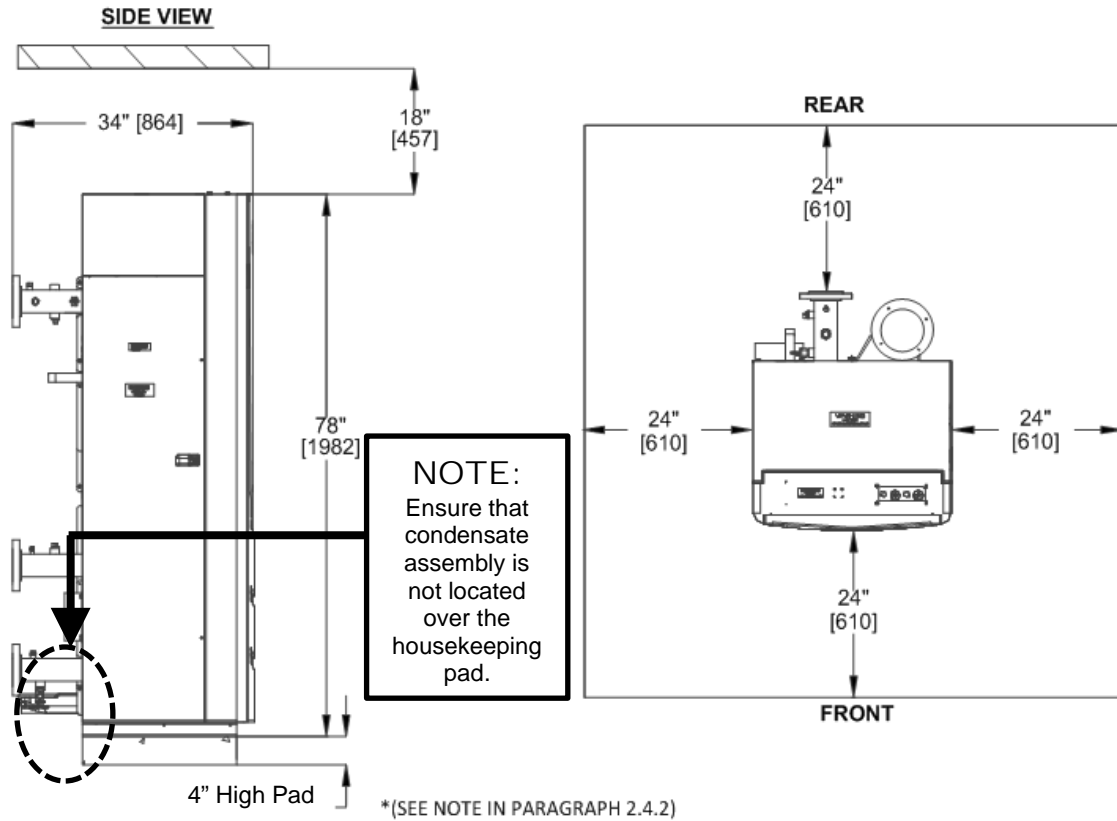
In multiple unit installations, it is important to plan the position of each unit in advance. Sufficient space for piping connections and future service/maintenance requirements must also be taken into consideration. All piping must include ample provisions for expansion.

**NOTE:**

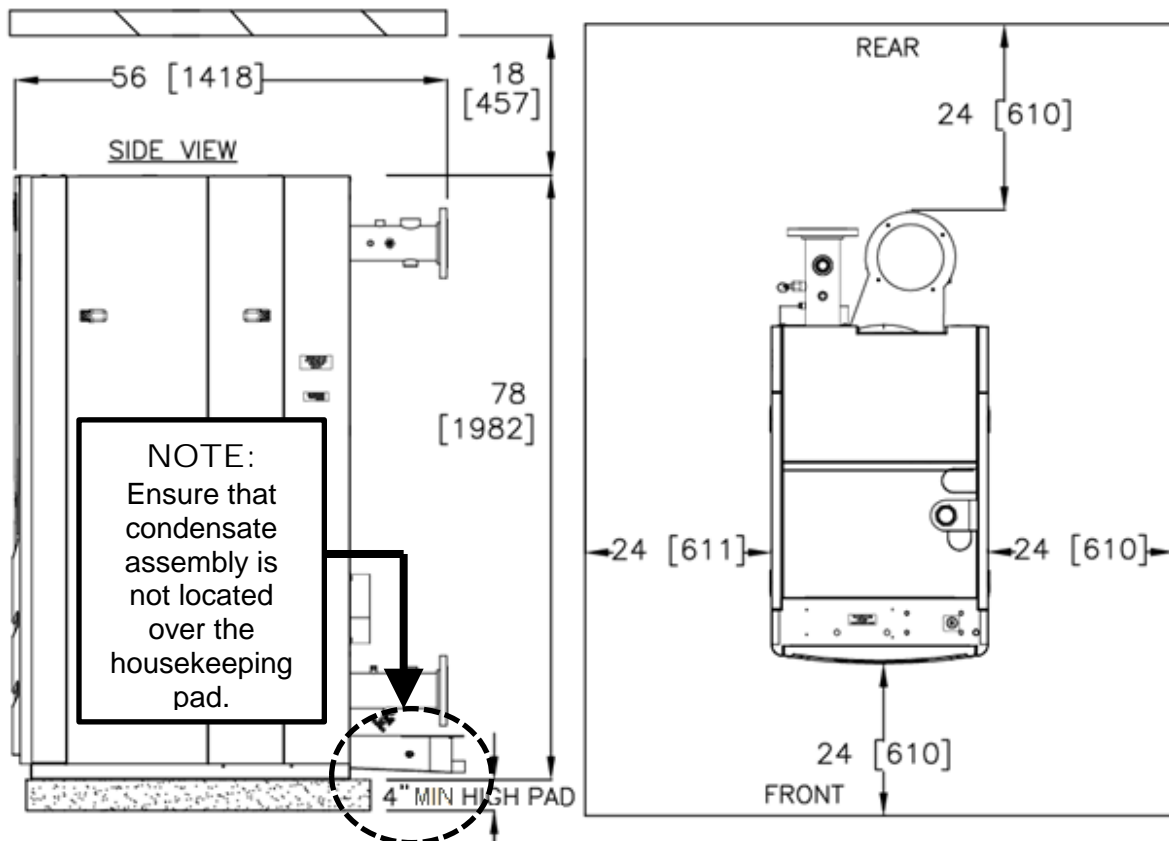
Benchmark 750 – 3000 units may be installed with zero side clearances in pairs only. The perimeter clearances still apply. See drawings in *Appendix A: Dimensions and Clearance Drawings*.

If installing a Combination (CCP) system using an ACS panel, it is important to identify the Combination Mode Boilers in advance and place them in the proper physical location. For information on Combination Mode Boilers refer to Section 3.7 of the *BMK PLATINUM 750 – 3000 Boiler Operation and Maintenance Guide*, OMM-0116 (GF-201).

SECTION 2 – INSTALLATION



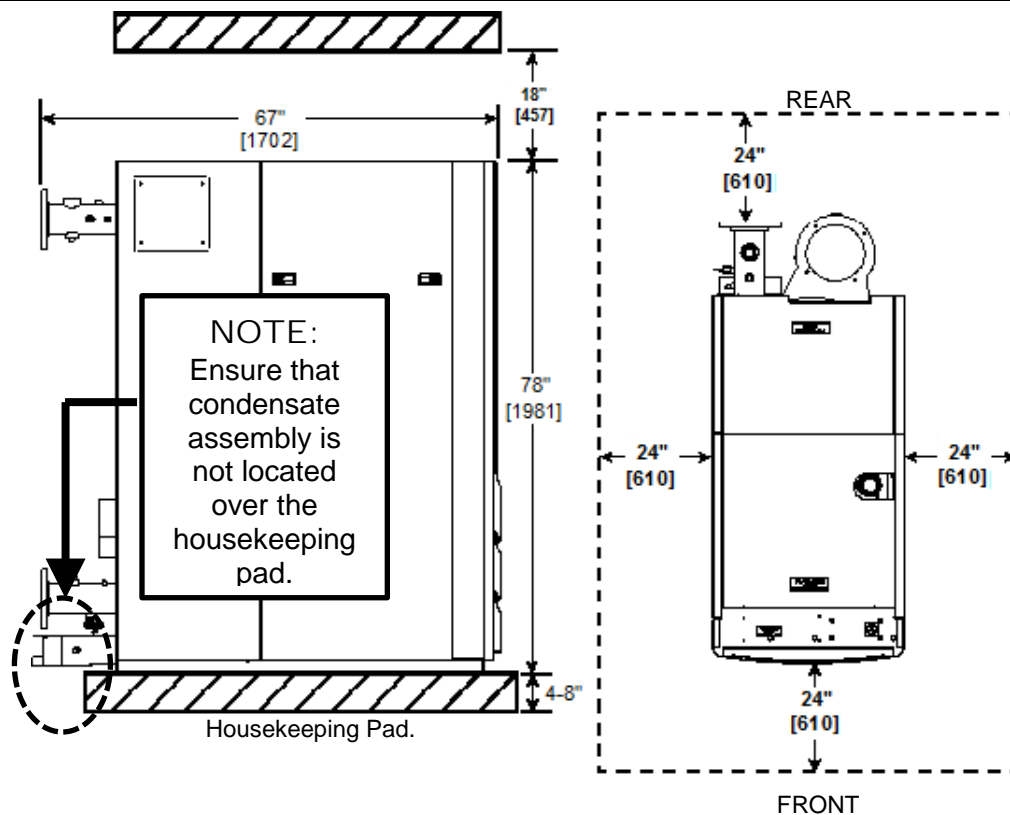
**Figure 2-1a: BMK 750/1000 Clearances**



**Figure 2-1b: BMK 1500/2000 Clearances**



SECTION 2 – INSTALLATION



**Figure 2-1c: BMK 2500/3000 Clearances**

**WARNING!**

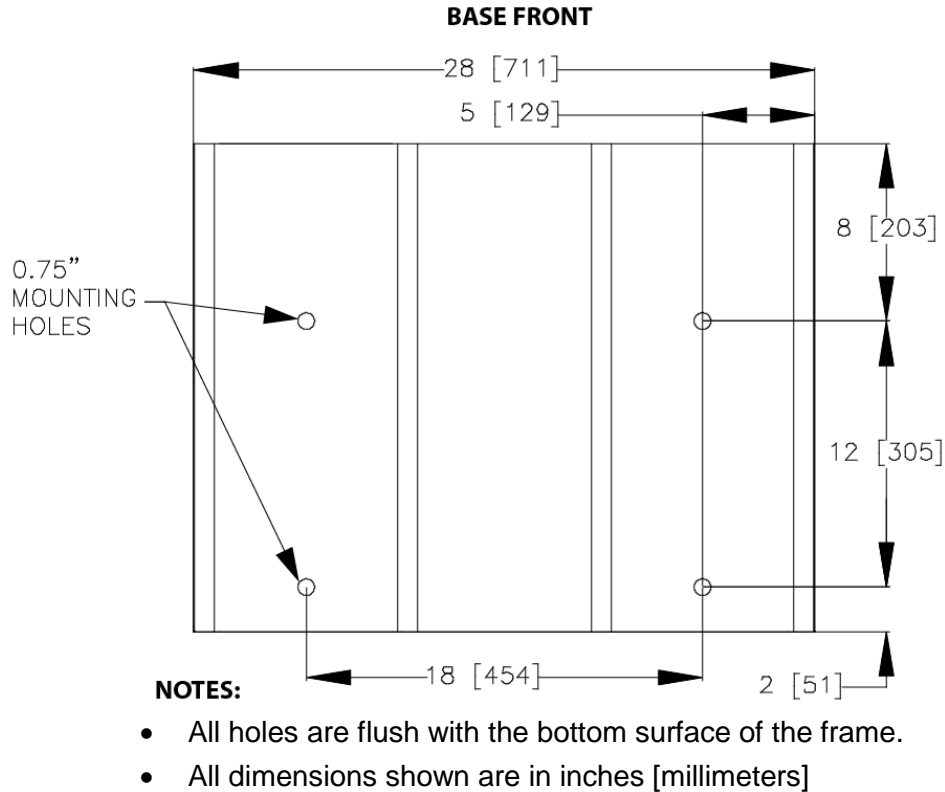
Keep the unit area clear and free from all combustible materials and flammable vapors or liquids.

**FOR MASSACHUSETTS ONLY:**

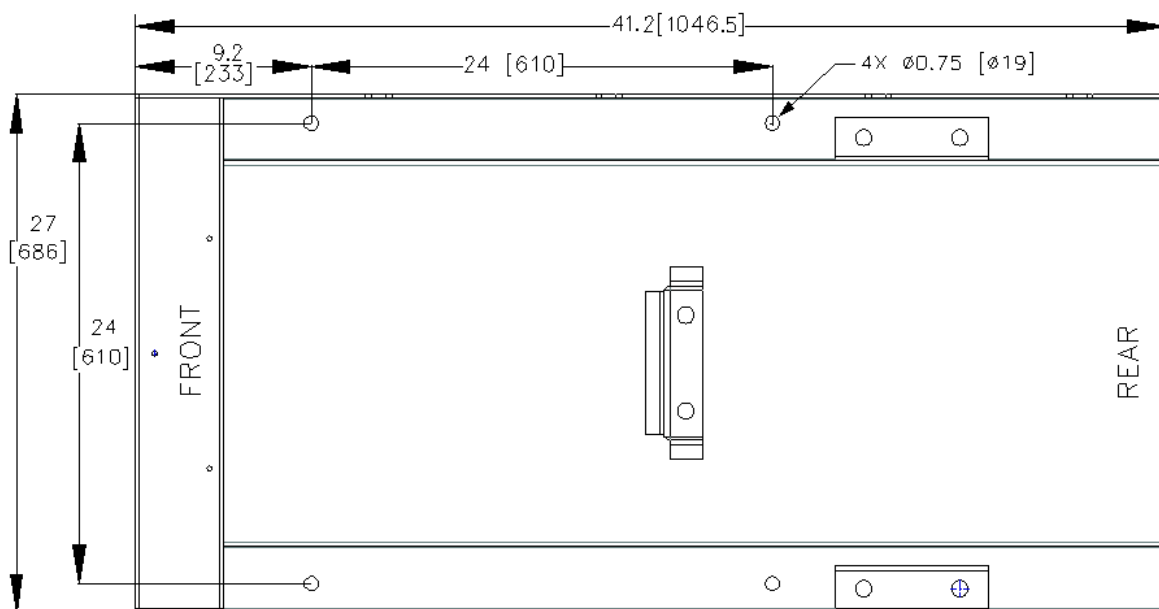
For Massachusetts installations, the unit must be installed by a plumber or gas-fitter licensed within the Commonwealth of Massachusetts. In addition, the installation must comply with all requirements specified in Section 1.4, above.

### 2.4.2 Setting the Unit

BMK 750/1000 units must be installed on a **4 to 6 inch (10.2 to 15.2 cm)** while BMK 1500 – 3000 units must be installed on a **4 to 8 inch (10.2 to 20.3 cm)** housekeeping pad to ensure proper condensate drainage. If anchoring the unit, refer to Figure 2-2a, 2-2b and 2-2c for anchor locations.

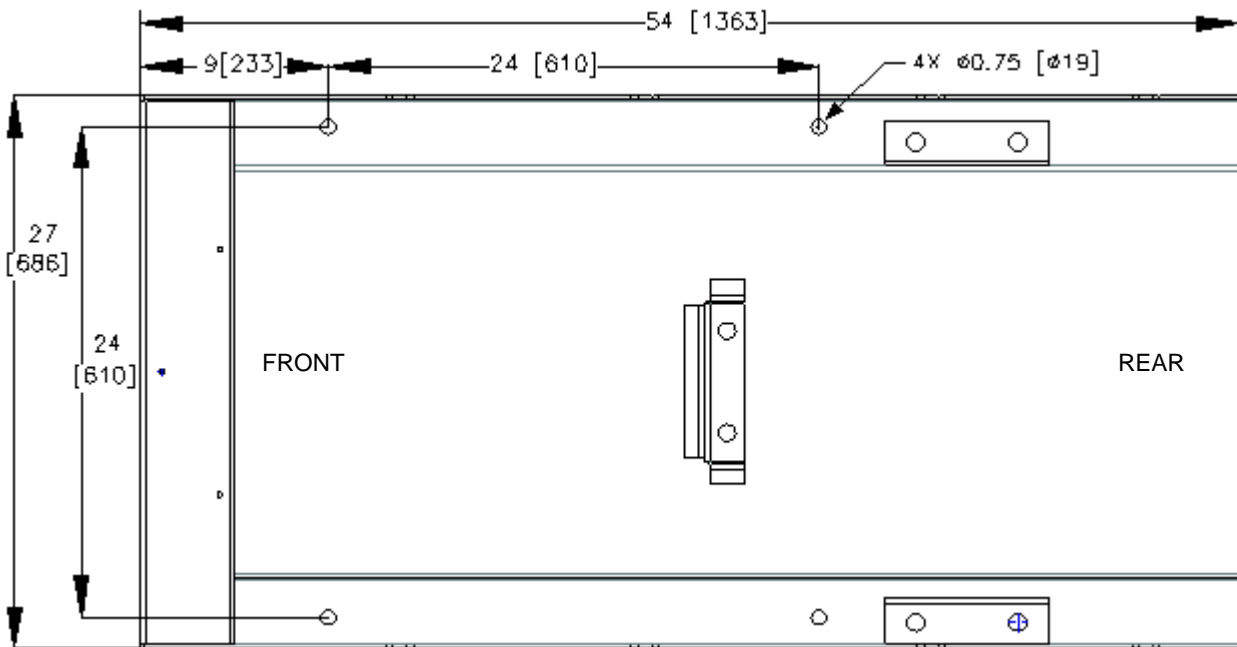


**Figure 2-2a: BMK 750/1000 Anchor Bolt Locations**



**Figure 2-2b: BMK 1500/2000 Anchor Bolt Locations**

SECTION 2 – INSTALLATION



NOTES:

- 1) ALL HOLES ARE FLUSH WITH THE BOTTOM SURFACE OF THE FRAME
- 2) ALL DIMENSIONS SHOWN ARE IN INCHES [MILLIMETERS]

**Figure 2-2c: BMK 2500/3000 Anchor Bolt Locations**

## 2.5 LIFTING PROVISIONS

### WARNING!

When lifting or moving the boiler, **DO NOT** attempt to manipulate the boiler using the gas train or blower.

### 2.5.1 BMK 750 – 1000 lifting Provisions

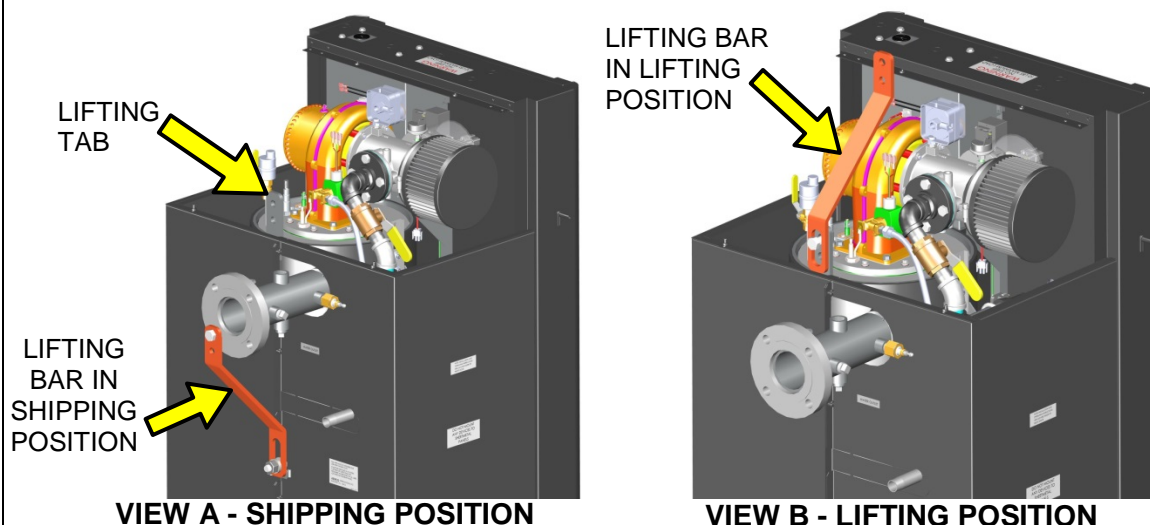
Unpack and inspect the unit, then remove the four (4) lag screws securing the boiler to the shipping pallet. The boiler can be lifted and moved by inserting forklift tines in the front slots provided in the base of the unit, or it can be lifted by attaching a lifting bar to the unit's heat exchanger. A lifting bar (P/N **59174**), with attaching hardware, is supplied with each unit. When shipped, this bar is attached to the rear of the unit as shown in Figure 2-3a (View A). One (1) lifting tab is provided at the top of the unit's heat exchanger as shown. This tab is used to attach the lifting bar to the unit, as described below.

### WARNING!

When using the lifting tab and bar, ensure there is no load placed on the gas train or blower.

#### Attaching the Lifting Bar: BMK 750/1000 Instructions

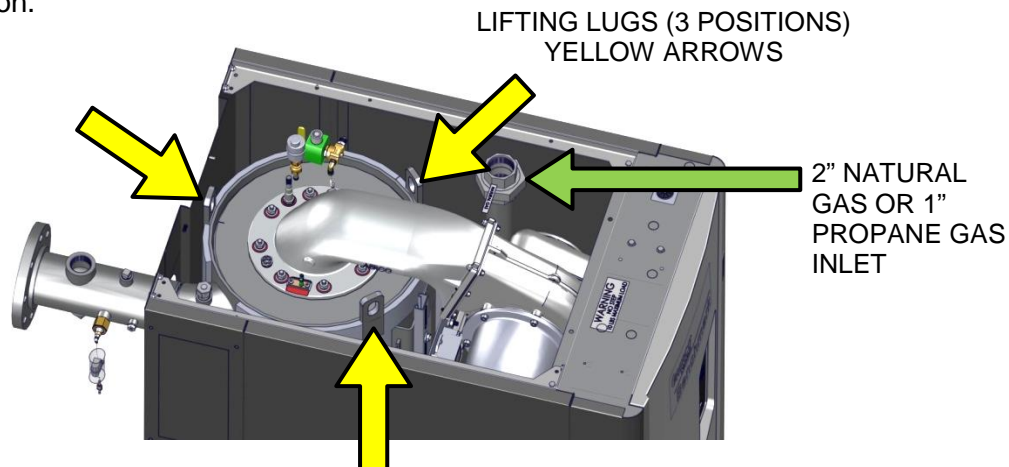
1. Remove the lifting bar from its shipping location at the rear of the unit (Figure 2-3a, View A). Retain the two (2) hex head cap screws, hex nuts and flat washers.
2. Remove the top shroud from the boiler and locate the lifting tab at the top-rear of the heat exchanger.
3. Attach the lifting bar to the heat exchanger lifting tab using the hardware removed in step 1 (Fig. 2-3a, View B). The upper end of the lifting bar containing the oval cutout should be positioned over the top of the heat exchanger as shown.
4. Using proper rigging equipment capable of lifting **1200 lbs. (544 kg)**, lift the boiler and position it on the housekeeping pad.
5. After the boiler is properly set on the pad, detach the lifting bar and replace the shroud on the top of the unit, but retain the lifting bar for possible reuse at the installation site.



**Figure 2-3a: BMK 750/1000 Boiler Lifting Provisions**

### 2.5.2 BMK 1500 – 3000 Lifting Provisions

Three lifting lugs are provided at the top of the primary heat exchanger as shown in Figure 2-3. Remove the front top panel from the unit to provide access to the lifting lugs. Remove the four (4) lag screws securing the unit to the shipping skid. Lift the unit off the shipping skid and position it on the **4 inch to 8 inch (10.2 cm to 20.3 cm)** housekeeping concrete pad (required) in the desired location.



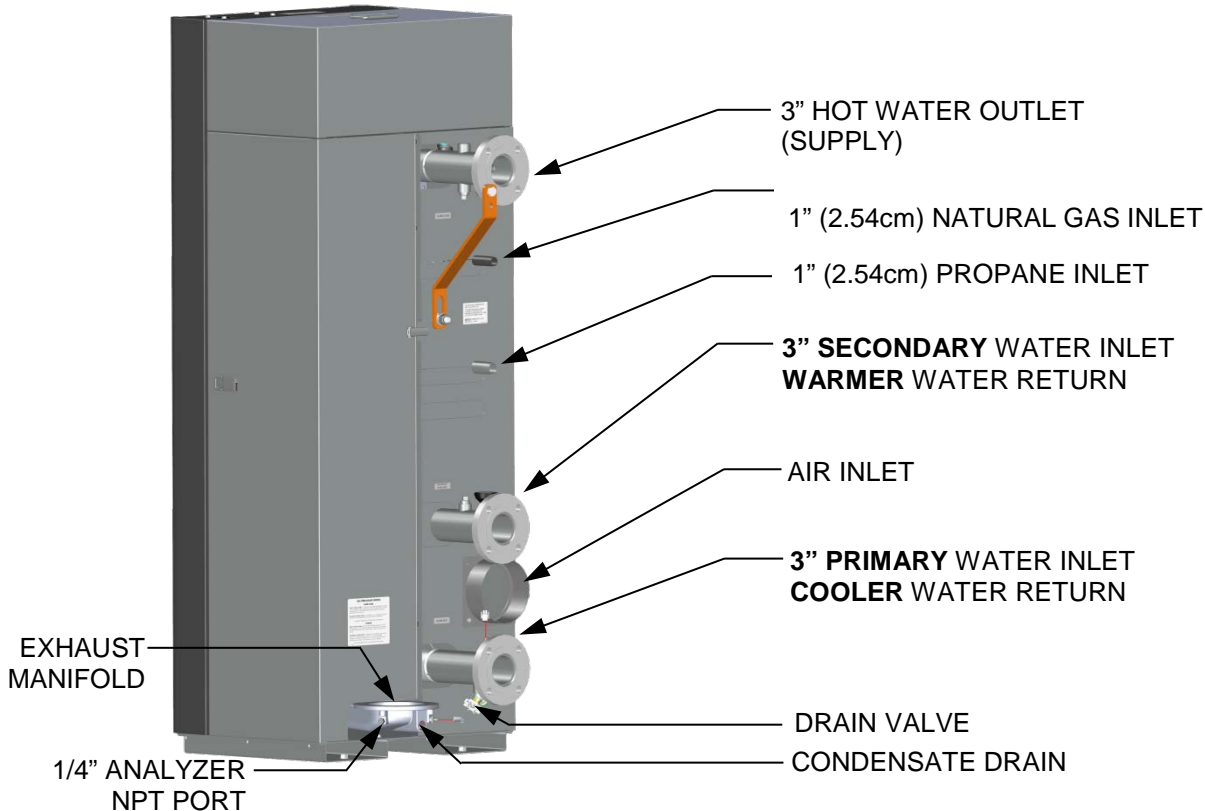
**Figure 2-3: Boiler Lifting Provisions – BMK 1500/2000 Shown**

## 2.6 SUPPLY AND RETURN PIPING

### 2.6.1 BMK 750 – 1000 Supply and Return Piping

Benchmark 750 and 1000 Boiler utilizes 3” (7.62cm) 150# flanges for the water system supply and return piping connections. The physical location of the supply and return piping connections are on the rear of the unit as shown in Figure 2-4a. Refer to Appendix A for dimensional data.

When connecting the hot water outlet and cold water inlet to building piping, first make sure the mating surfaces are thoroughly clean. AERCO recommends using Loctite ® 7649 to prime the mating surfaces and then Loctite 567 as pipe dope. Do *NOT* use Teflon tape.

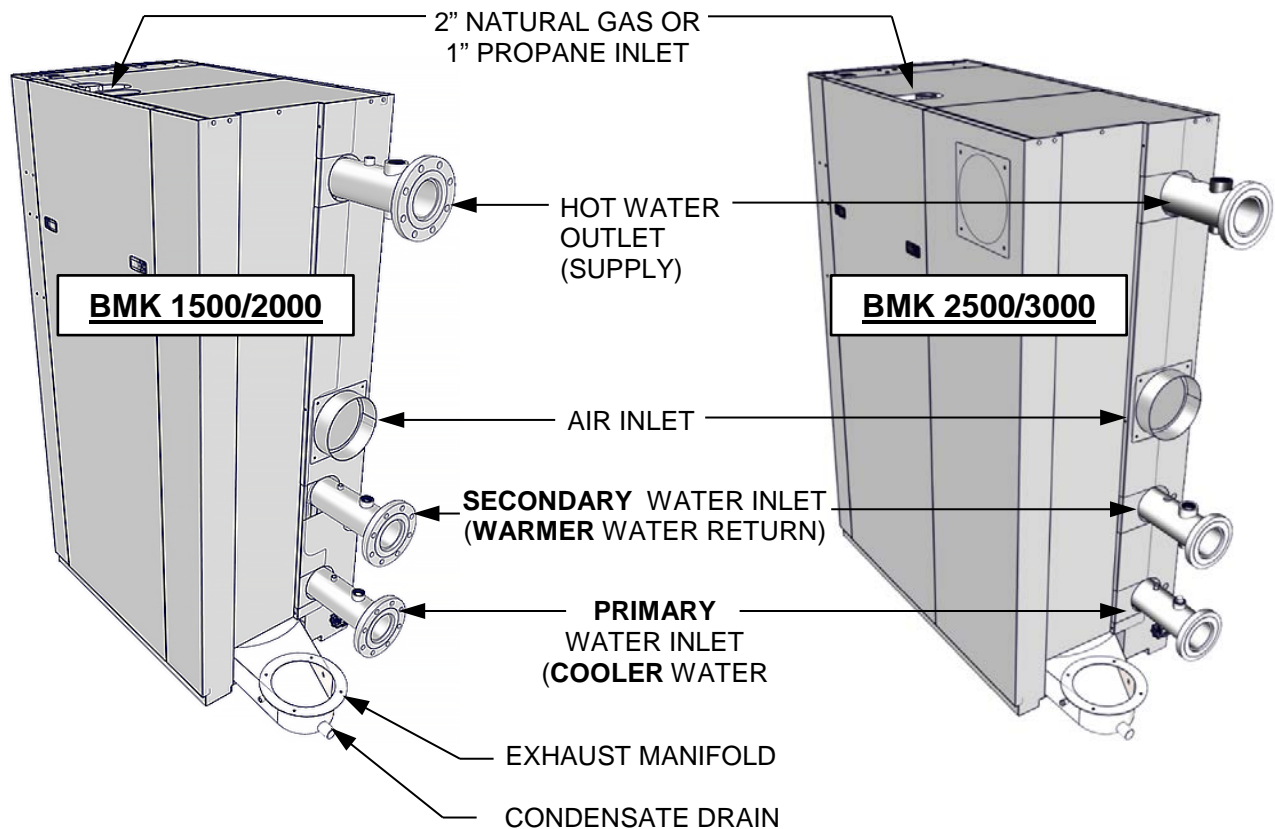


**Figure 2-4a: BMK 750/1000 Supply and Return Locations – Two Inlet Option Shown**

### 2.6.2 BMK 1500 – 3000 Supply and Return Piping

All Benchmark 1500, 2000, 2500 and 3000 units have one 4” (10.2 cm) 150# flanges for the water INLET (supply) and one 4” (10.2 cm) 150# flanges for the hot water OUTLET (return) piping connections. Some units have an optional second 4” (10.2 cm) 150# flange for the water INLET, as shown in Figure 2-4b. Refer to Appendix A for dimensional data.

When connecting the hot water outlet and cold water inlet to building piping, first make sure the mating surfaces are thoroughly clean. AERCO recommends using Loctite ® 7649 to prime the mating surfaces and then Loctite 567 as pipe dope. Do *NOT* use Teflon tape.



**Figure 2-4b: BMK 1500/2000 and BMK 2500/3000 Supply and Return Locations**

### 2.6.3 Dual Inlet Return Piping

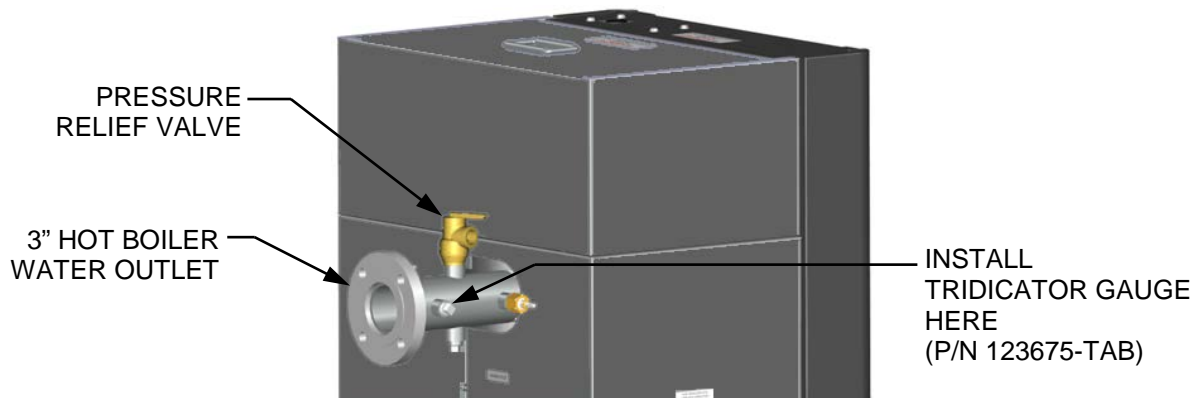
The standard dual inlet connections allow these units to be configured with a separate cooler return temperature zone, rather than blending high and low return temperature zones. Utilizing the dual return capability, these boilers can take further advantage of the condensing capabilities. When configured with a lower return temperature zone or AERCO SmartPlate, thermal efficiency can improve by up to 6% (Based on an 80 °F (26.7 °C) minimum return water temperature at full fire. Lower return temperatures are possible which would yield even greater efficiency gains. The maximum temperature differential across the boiler heat exchanger is 100 °F (37.8 °C).

To use the secondary inlet, pipe the **warmer** return water to the **secondary** (upper) inlet and the **cooler** return water to the **primary** (lower) inlet. If the flow through both the primary and the secondary return is constant, then the combined minimum flows must equal the specified minimum flow of the boiler. If the flow through either of the inlet returns is intermittent, then the minimum flow through one of the return connections must always equal the specified minimum flow of the boiler. Contact your AERCO representative for additional information.

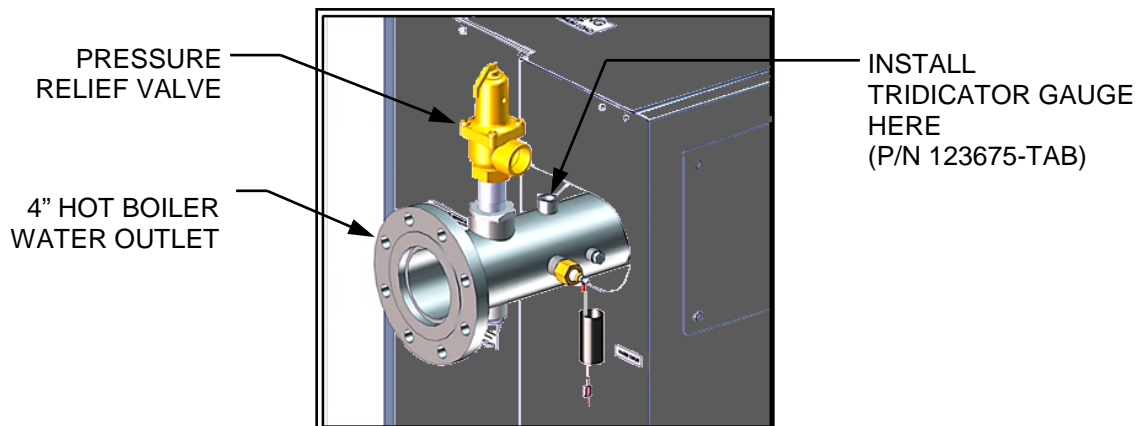


## 2.7 PRESSURE RELIEF VALVE INSTALLATION

An ASME rated Pressure Relief Valve is supplied with each Benchmark Boiler. The pressure rating for the relief valve must be specified on the sales order. Available pressure ratings range from 30 to 160 psi (207 to 1103 kPa). The relief valve is installed on the hot water outlet of the boiler as shown in Figure 2-5a and 2-5b. A suitable pipe joint compound should be used on the threaded connections. Any excess should be wiped off to avoid getting any joint compound into the valve body. The relief valve must be piped to **within 12 inches (30.5 cm)** of the floor to prevent injury in the event of a discharge. No valves, restrictions, or other blockages are allowed in the full port discharge line. In multiple unit installations the discharge lines must **NOT** be manifolded together. Each must be individually run to a suitable discharge location.



**Figure 2-5a: BMK 750/1000 P&T Relief Valve Location**



**Figure 2-5b: BMK 1500/2000/2500/3000 P&T Relief Valve Location**

## 2.8 CONDENSATE DRAIN and PIPING

The Benchmark Boiler is designed to condense water vapor from the flue products. Therefore, the installation must have provisions for suitable condensate drainage or collection. See the following subsections for information on the condensate drain and piping for the various models.

The condensate drain port located on the exhaust manifold (see Figure 2-4a and 2-4b) must be connected to the condensate trap (P/N **24441**), which is packed separately within the unit’s shipping container. The condensate trap inlet and outlet connections contain tapped 3/4” NPT ports.

A sample condensate trap installation is shown in Figure 2-6a and 2-6b. However, the actual installation details for the trap will vary depending on the available clearances, housekeeping pad height/dimensions and other prevailing conditions at the site. The following general guidelines must be observed to ensure proper condensate drainage:

- The condensate trap inlet must be level with, or lower than the exhaust manifold drain port.
- The base of the condensate trap must be supported to ensure that it is level (horizontal).
- The trap must be removable for routine maintenance. AERCO recommends that a union be utilized between the exhaust manifold condensate drain port and the trap inlet port.

While observing the above guidelines, install the condensate trap as follows:

### Condensate Drain Installation Instructions

1. Connect the condensate trap inlet to the exhaust manifold drain connection using the appropriate piping components (nipples, reducers, elbows, etc.).
2. At the condensate trap outlet, install a 3/4” NPT nipple.
3. Connect a length of 1” (2.54 cm) I.D. polypropylene hose to the trap outlet and secure with a hose clamp.
4. Route the hose on the trap outlet to a nearby floor drain.

If a floor drain is not available, a condensate pump can be used to remove the condensate to an appropriate drain. **The maximum condensate flow rate is:**

Model	Maximum Condensate Flow Per Boiler
BMK 750	6 gallons (23 L) per hour
BMK 1000	8 gallons (30 L) per hour
BMK 1500	9 gallons (34 L) per hour
BMK 2000	10 gallons (38 L) per hour
BMK 2500	17 gallons (64 L) per hour
BMK 3000	20 gallons (76 L) per hour

### WARNING!

Use PVC, stainless steel, aluminum or polypropylene for condensate drain piping. Do **NOT** use carbon or copper components.

SECTION 2 – INSTALLATION

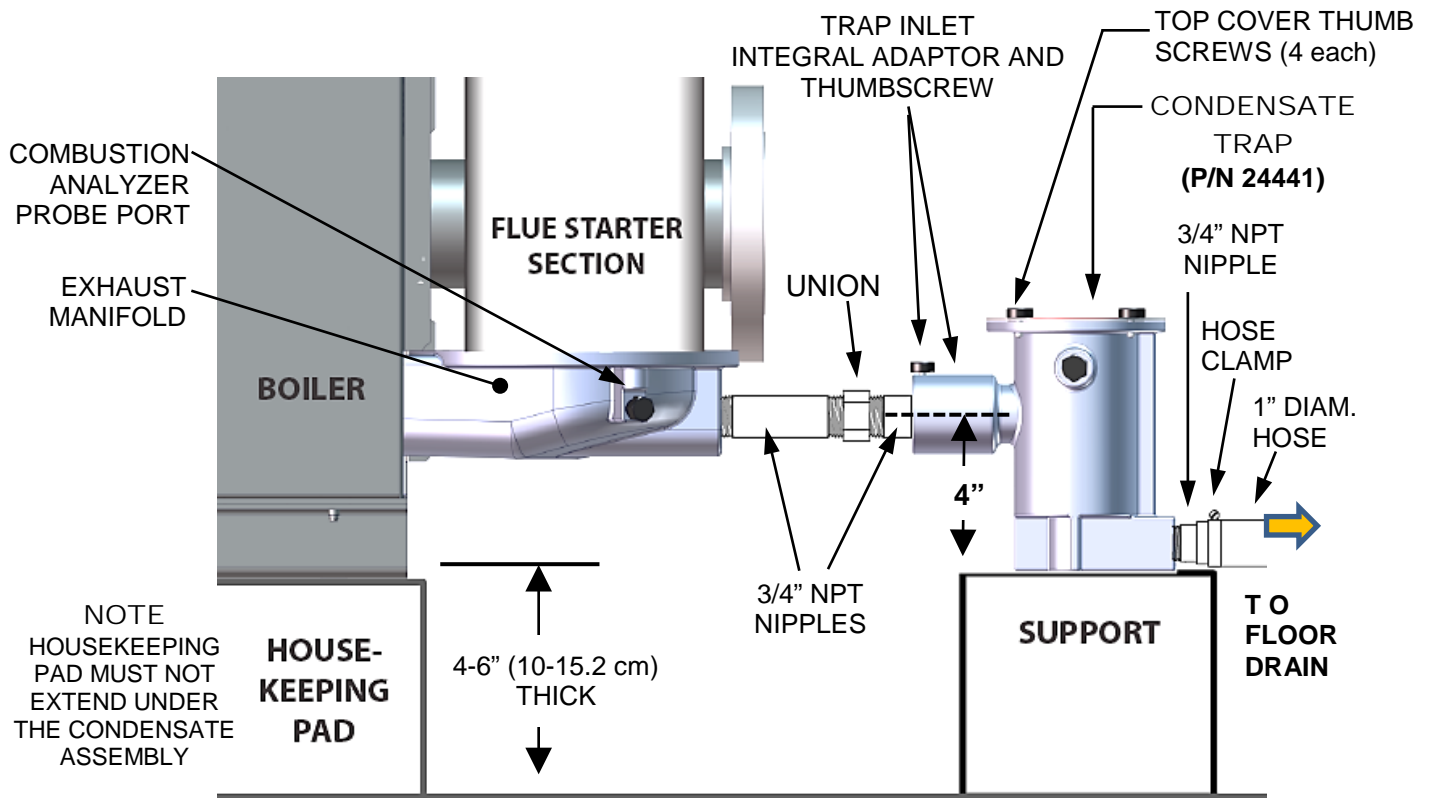


Figure 2-6a: BMK 750/1000 Sample Condensate Trap Installation

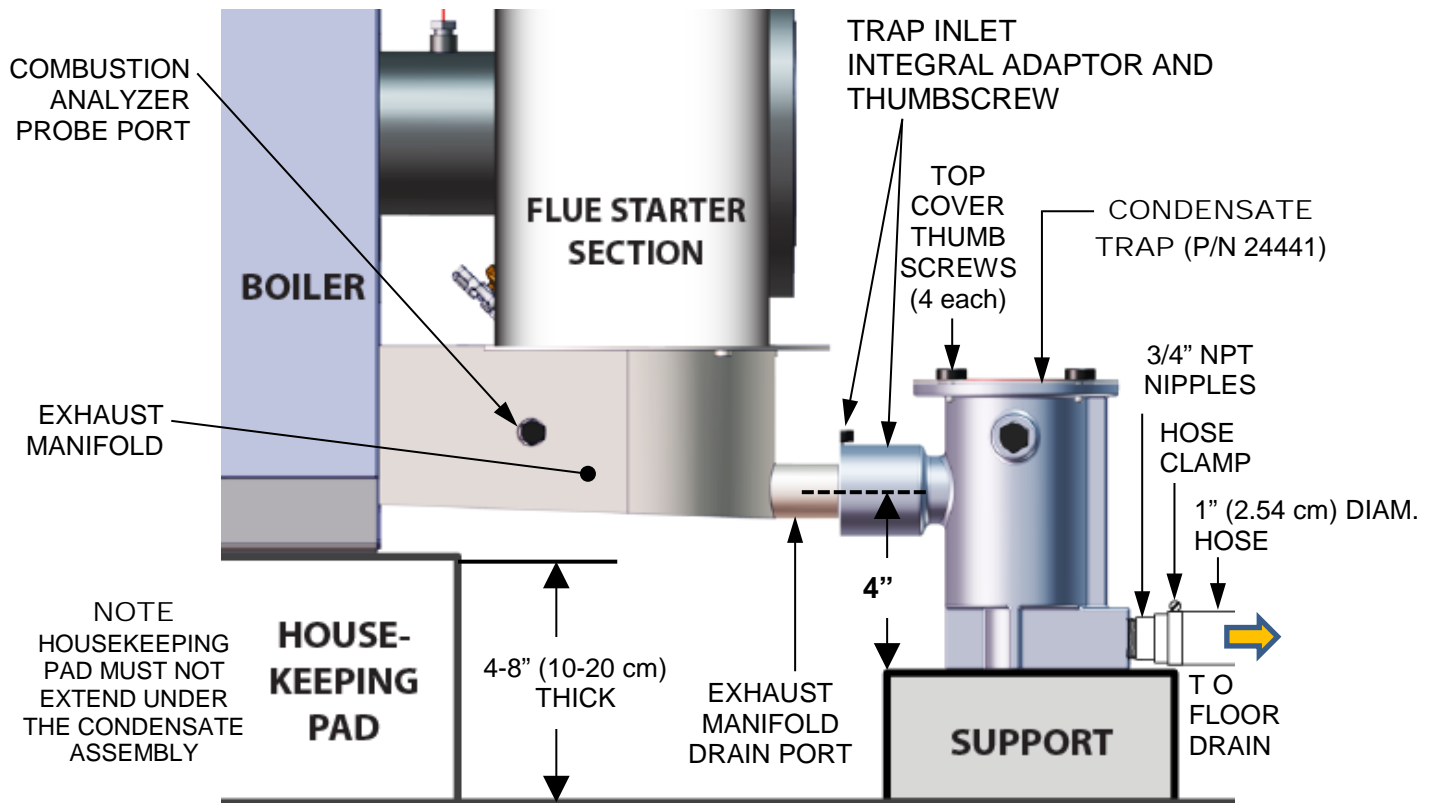


Figure 2-6b: BMK 1500 – 3000 Sample Condensate Trap Installation

## 2.9 GAS SUPPLY PIPING

AERCO's *Benchmark Gas Components and Supply Design Guide, TAG-0047 (GF-2030)* must be consulted prior to designing or installing any gas supply piping.

### WARNING!

**NEVER USE MATCHES, CANDLES, FLAMES OR OTHER SOURCES OF IGNITION TO CHECK FOR GAS LEAKS.**

### CAUTION!

Many of the soaps used for gas pipe leak testing are corrosive to metals. Therefore, piping must be rinsed thoroughly with clean water after leak checks have been completed.

### NOTE:

All gas piping must be arranged so that it does not interfere with removal of any covers, inhibit service/maintenance, or restrict access between the unit and walls, or another unit.

**Benchmark 750 and 1000:** Features a 1 inch (2.54 cm) NATURAL GAS gas inlet connection on the rear of the unit.

**Benchmark 750P and 1000P:** Features a 1 inch (2.54 cm) PROPANE gas inlet connection on the rear of the unit.

**Benchmark 1500/2000/2500/3000:** Features a 2 inch (5.08 cm) NATURAL GAS gas inlet connection on the top of the unit.

**Benchmark 1500P, 2000P, 2500P, and 3000P (Propane):** Features a 1 inch (2.54 cm) PROPANE gas inlet connection on the top of the unit.

**Benchmark 1500DF, 2000DF, 2500DF, and 3000DF (Dual Fuel):** Features a 2 inch (5.08 cm) NATURAL GAS and a 1 inch (2.54 cm) PROPANE gas inlet connection on the top of the unit.

Prior to installation, all pipes should be de-burred and internally cleared of any scale, metal chips or other foreign particles. Do *NOT* install any flexible connectors or unapproved gas fittings. Piping must be supported from the floor, ceiling or walls only and must not be supported by the unit.

A suitable piping compound, approved for use with natural gas, should be used. Any excess must be wiped off to prevent clogging of components.

To avoid unit damage when pressure testing gas piping, the unit must be isolated from the gas supply piping. The gas pressure applied to the unit **must never exceed 14" W.C. (3.49 kPa)**. A thorough leak test of all external piping must be performed using a soap and water solution or suitable equivalent. The gas piping used must meet all applicable codes.

### 2.9.1 Gas Supply Specifications

The gas supply input specifications to the unit are as follows:

The maximum static pressure to the unit must not exceed the following:

**TABLE 2-1: Maximum Static Gas Pressure**

Model	Natural gas	Propane
<b>BMK 750 - BMK 3000</b>	14" W.C. (3.49 kPa)	14" W.C. (3.49 kPa)

Supply piping and pressure to the unit must be sufficient to provide the volume of gas while maintaining gas pressure listed below while **operating at maximum capacity**.

**TABLE 2-2: Minimum Gas Pressure Requirements**

Model	Natural gas	Propane
<b>BMK 750</b>	4" W.C. (1.0 kPa)	7" W.C. (1.74 kPa)
<b>BMK 1000</b>	4" W.C. (1.0 kPa)	11" W.C. (2.74 kPa)
<b>BMK 1500</b>	4" W.C. (1.0 kPa)	4" W.C. (1.0 kPa)
<b>BMK 2000 *</b>	4" W.C. (1.0 kPa)	4" W.C. (1.0 kPa)
<b>BMK 2500</b>	4" W.C. (1.0 kPa)	4" W.C. (1.0 kPa)
<b>BMK 3000</b>	4" W.C. (1.0 kPa)	4" W.C. (1.0 kPa)

\* The BMK 2000 may derate by up to 150,000 BTU's when operated **below 5" W.C. (1245 Pa)** at full fire.

### 2.9.2 Manual Gas Shutoff Valve

A manual shut-off valve must be installed in the gas supply line upstream of the boiler as shown in Figure 1-1.

### 2.9.3 External Gas Supply Regulator

An external gas pressure regulator is required on the gas inlet piping under most conditions (see, below). Regulators must conform to the specifications shown in the tables below.

The external natural gas regulator must be capable of regulating the following BTU per hour while maintaining the minimum gas pressure listed below:

TABLE 2-3a: NATURAL GAS Regulator Capacity		
Model	BTU/HR (kW)	Minimum Gas Pressure
BMK 750/1000	49,000 – 1,020,000 (14.3 – 299)	4.0” W.C. (1.0 kPa)
BMK 1500	100,000 – 2,120,000 (29.3 - 621.3)	6.0” W.C. (1.49 kPa)
BMK 2000	100,000 – 2,120,000 (29.3 - 621.3)	8.5” W.C. (2.12 kPa)
BMK 2500/3000	150,000 – 3,180,000 (44 - 932)	8.0” W.C. (1.99 kPa)

TABLE 2-3b: PROPANE Gas Regulator Capacity		
Model	BTU/HR (kW)	Minimum Gas Pressure
BMK 750/1000	49,000 – 1,020,000 (14.3 – 299)	11.0” W.C. (2.74 kPa)
BMK 1500/2000	100,000 – 2,120,000 (29.3 - 621.3)	4.0” W.C. (1.0 kPa)
BMK 2500/3000	150,000 – 3,180,000 (44 - 932)	4.0” W.C. (1.0 kPa)

A lock-up style regulator **MUST** be used when gas supply pressure will exceed 14” W.C. (3.49 kPa).

#### 2.9.3.1 Massachusetts Installations Only

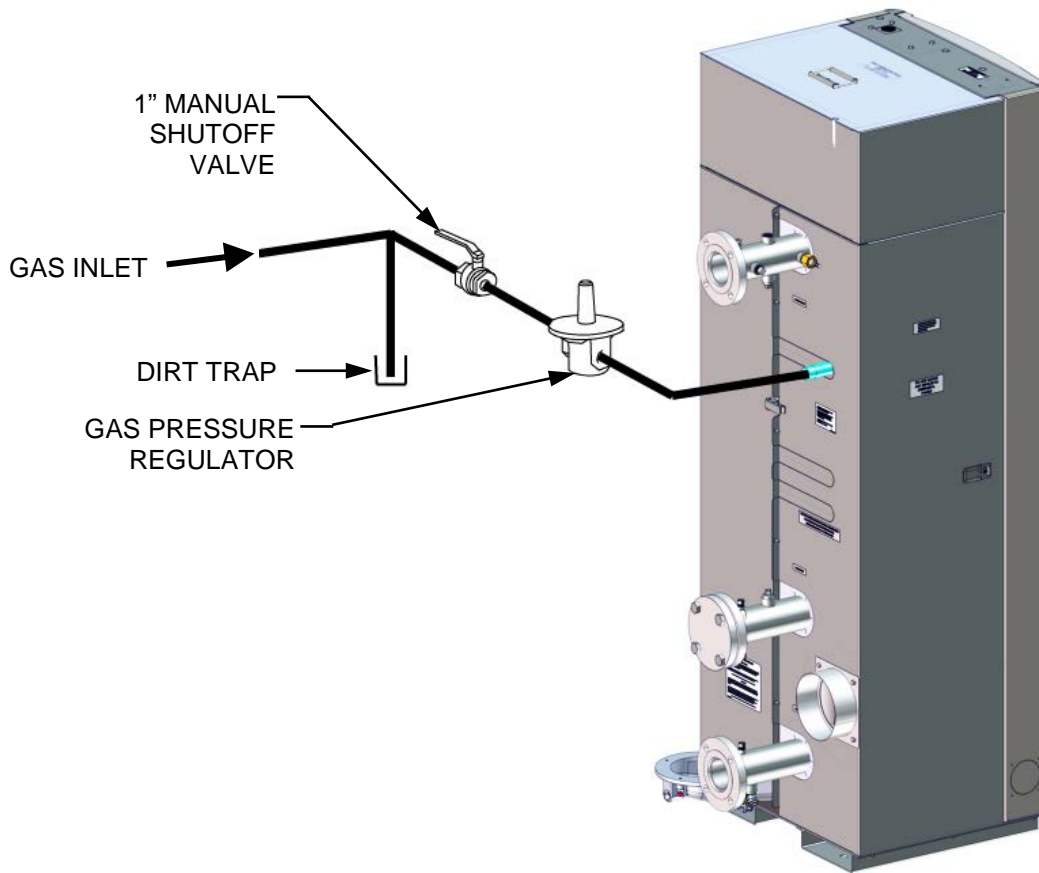
For Massachusetts installations, a mandatory external gas supply regulator must be positioned as shown in Figure 2-7a, 2-7b and 2-7c. The gas supply regulator must be properly vented to outdoors. Consult the local gas utility for detailed requirements concerning venting of the supply gas regulator.

#### 2.9.3.2 All Installations (Except Massachusetts)

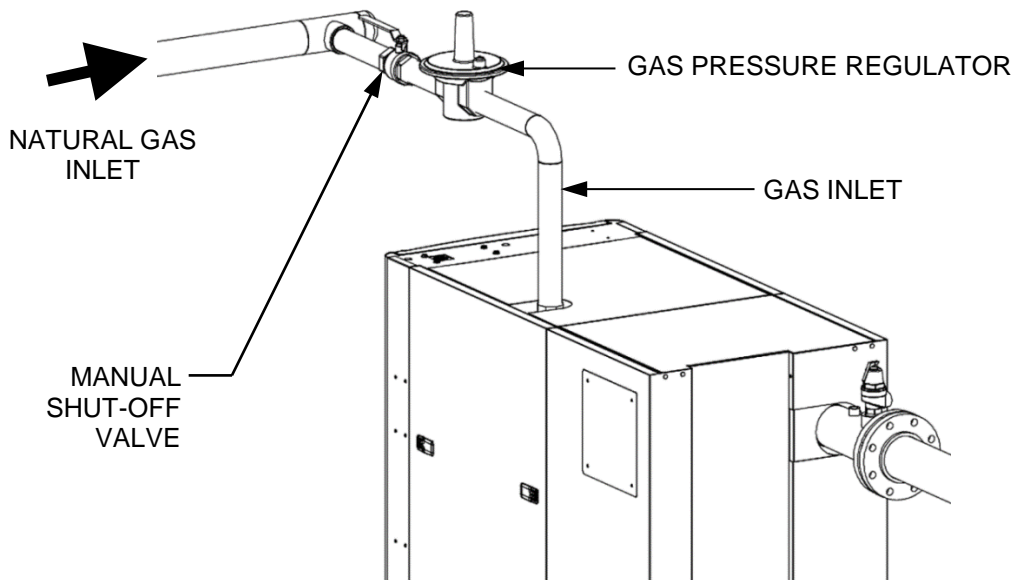
For installations with 3 or more units (other than Massachusetts) that **EXCEED 7” W.C. (1.7 kPa)** gas pressure, a separate external gas supply regulator, as shown in Figure 2-7a, 2-7b and 2-7c, **is highly recommended**. No regulator is required for gas pressures **below 7” W.C. (1.7 kPa)** of pressure. Consult the local gas utility for detailed requirements concerning venting of the supply gas regulator.

**NOTE:**

It is the responsibility of the customer to source and purchase the appropriate gas regulator as described above. However, AERCO offers for sale an appropriate regulator, which may be ordered at the time of unit purchase or separately. Contact your AERCO sales representative for more information.

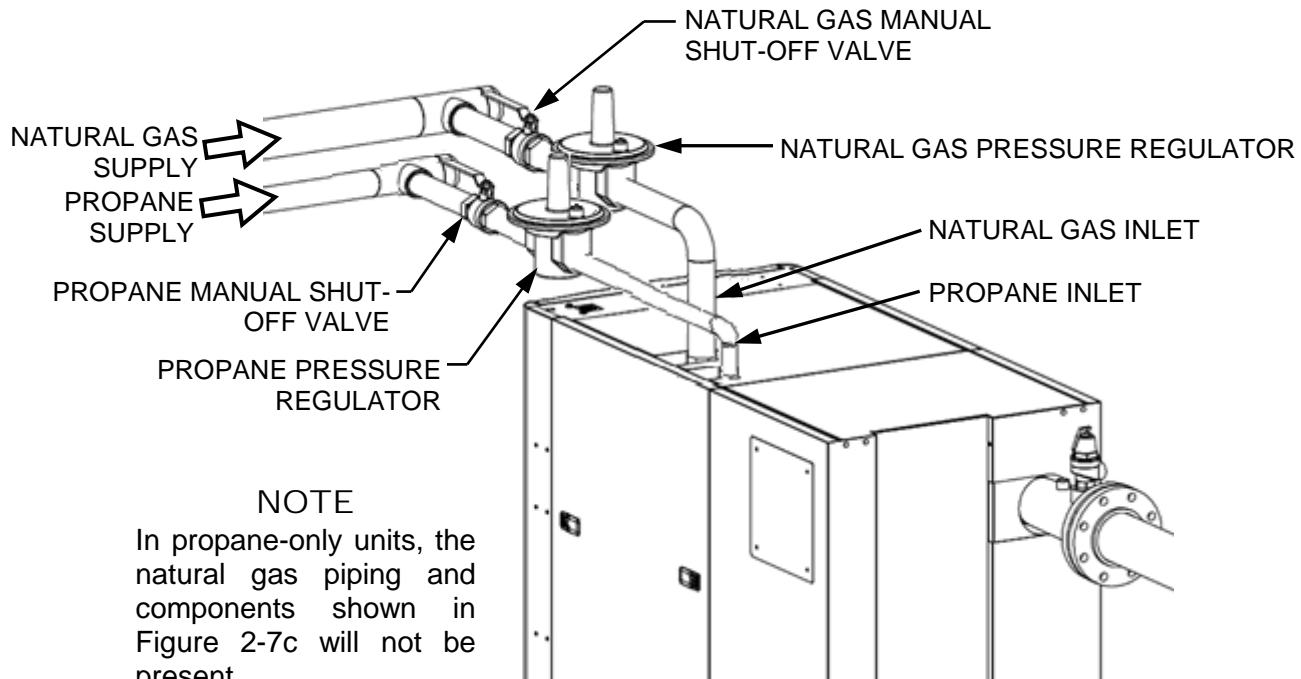


**Figure 2-7a: BMK 750/1000 Manual Gas Shut-Off Valve and Gas Regulator**



**Figure 2-7b: BMK 1500-3000 Manual Gas Shut-Off Valve and Gas Regulator**





**Figure 2-7c: BMK 1500-3000DF Dual Fuel Manual Gas Shut-Off Valve & Gas Regulator**

## 2.10 AC ELECTRICAL POWER WIRING

AERCO's *Benchmark Electrical Power Guide*, TAG-0048 (GF-2060), must be consulted prior to connecting any AC power wiring to the unit.

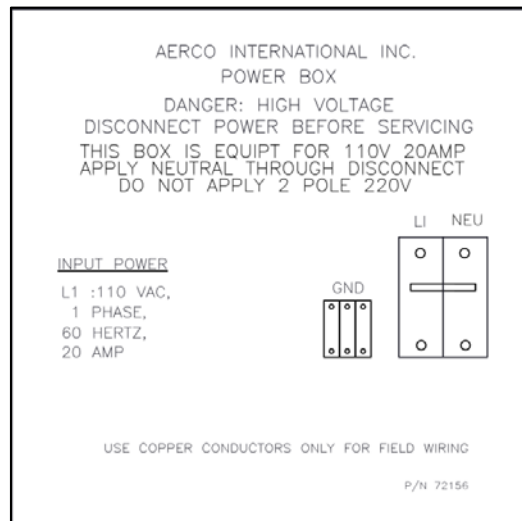
### 2.10.1 Electrical Power Requirements

The BMK models covered by this manual are available in the following voltage configurations:

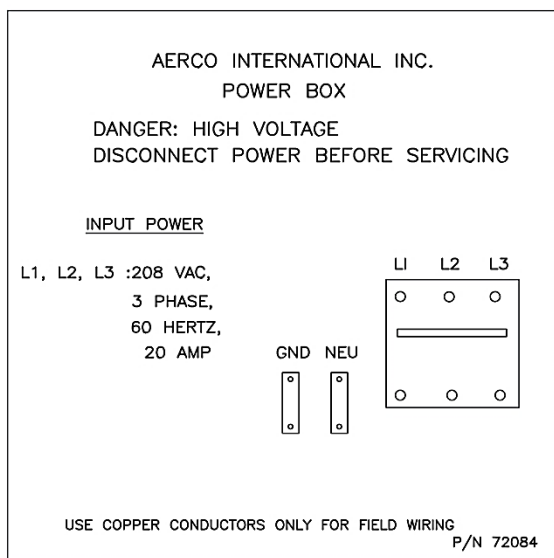
- **BMK 750/1000:** 120 VAC, Single-Phase, 60 Hz @ 20 Amps
- **BMK 1500/2000:** 120 VAC, Single-Phase, 60 Hz @ 20 Amps
- **BMK 2500-3000/208:** 208 VAC, Three-Phase, 60 Hz @ 20 Amps
- **BMK 2500-3000/460:** 460 VAC, Three-Phase, 60 Hz @ 15 Amps

A label showing the required AC power connections is provided on the front cover of the Power Box as shown below in Figures 2-8a and 2-8b. The location of the power box is shown in Section 2.10.2, below.

SECTION 2 – INSTALLATION



**Figure 2-8a: Power Box Cover Label – BMK 750 – 2000**



**BMK 2500/3000 - 208VAC**



**BMK 2500/3000 - 460VAC**

**Figure 2-8b: Power Box Cover Labels – BMK 2500/3000**

Each unit must be connected to a dedicated electrical circuit. **NO OTHER DEVICES SHOULD BE ON THE SAME ELECTRICAL CIRCUIT AS THE BOILER.**

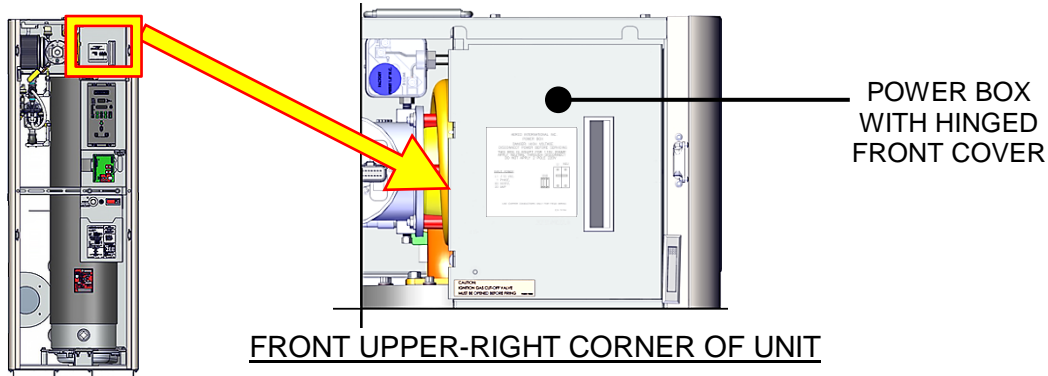
A switch must be installed on the electrical supply line in an easily accessible location to quickly and safely disconnect electrical service. DO NOT attach the switch to sheet metal enclosures of the unit.

After placing the unit in service, the ignition safety shutoff device must be tested. If an external electrical power source is used, the installed boiler must be electrically bonded to ground in accordance with the requirements of the authority having jurisdiction. In the absence of such requirements, the installation shall conform to National Electrical Code (NEC), ANSI/NFPA 70 and/or the Canadian Electrical Code (CEC) Part I, CSA C22.1 Electrical Code.

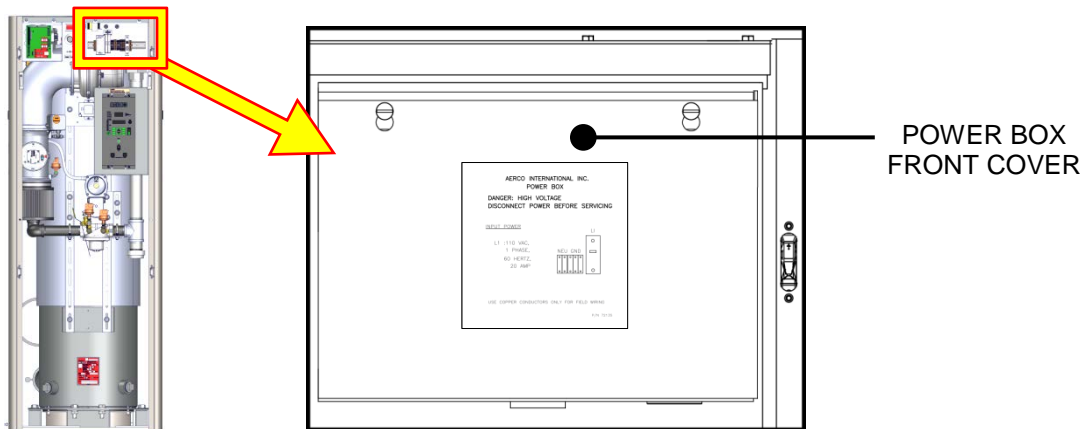
For electrical power wiring diagrams, see the *Benchmark Electrical Power Guide*, TAG-0048 (GF-2060).

## 2.10.2 Power Box Locations

External AC power connections are made to the unit inside the Power Box on the front of the unit. Remove the front panel to access the Power Box, which is mounted in the upper part of the unit as shown in Figure 2-9a and 2-9b. The internal connections inside the power box is shown in Section 2.10.3, below.



**Figure 2-9a: BMK 750/1000 Power Box with Closed Cover**

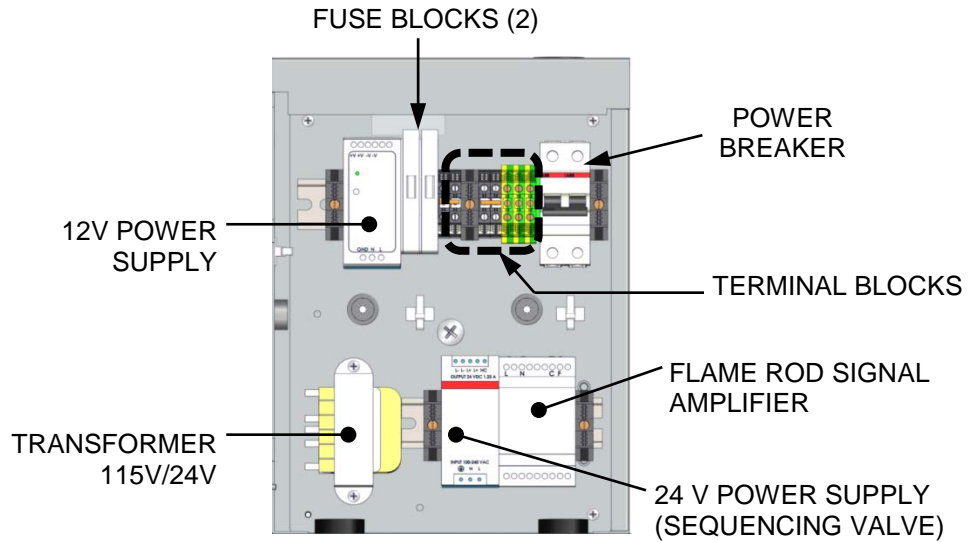


**Figure 2-9b: BMK 1500/2000/2500/3000 Power Box with Closed Cover**

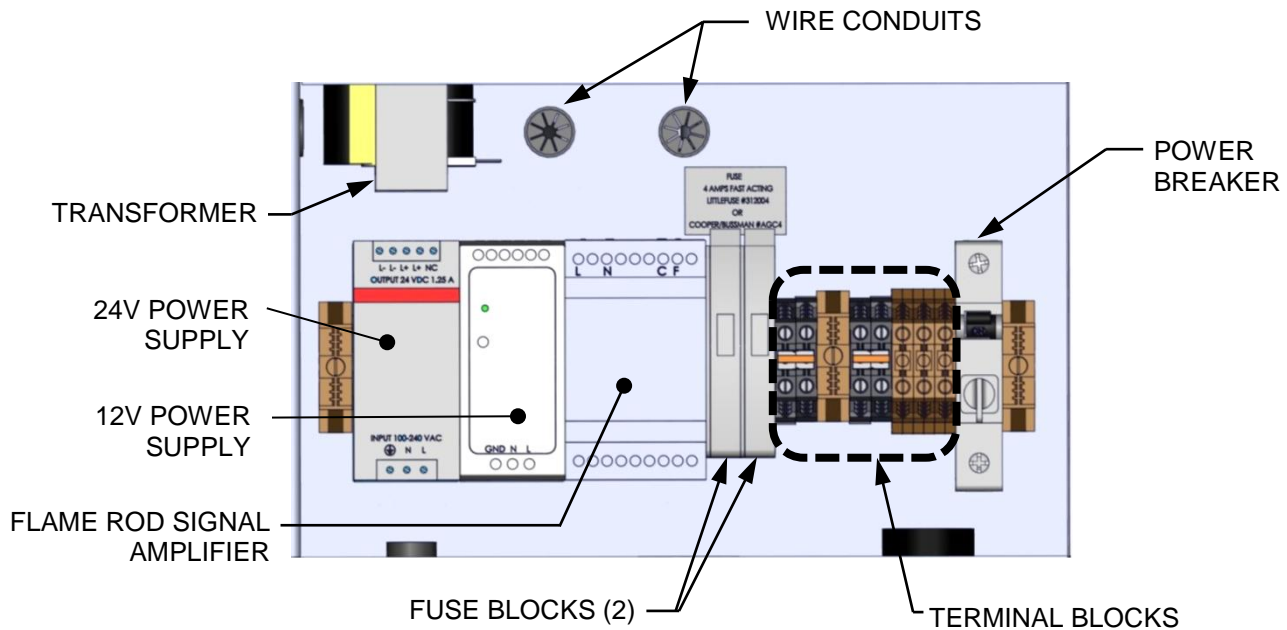
### 2.10.3 Electrical Power Box Internal Components

**WARNING!**

The power breaker shown in Figure 2-10a, 2-10b and 2-10c does **NOT** remove power from the terminal blocks.

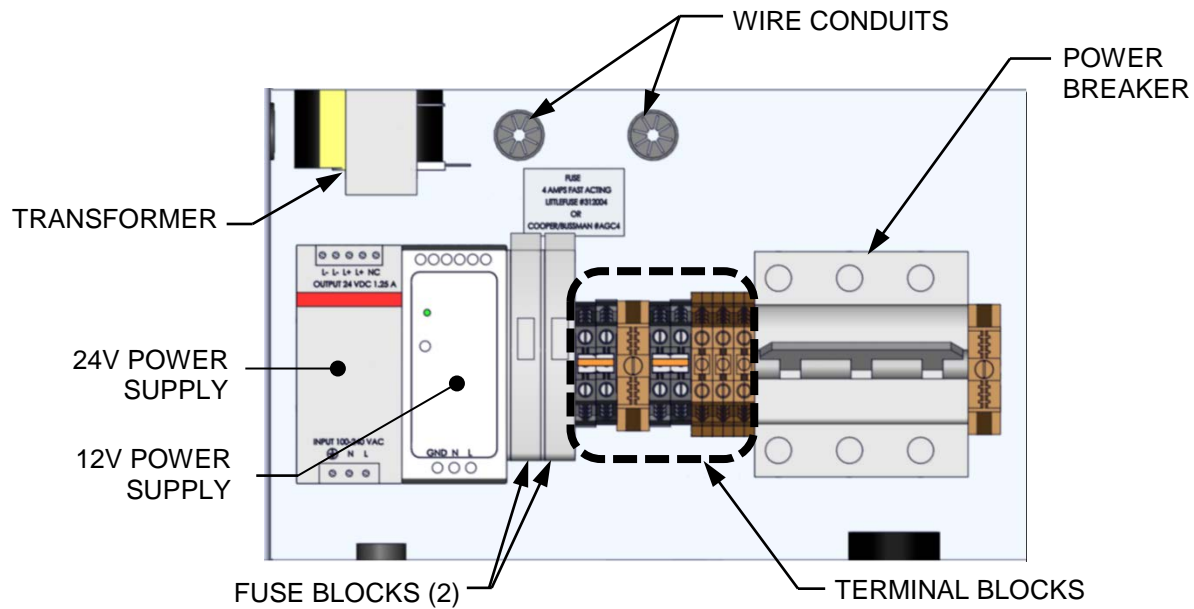


**Figure 2-10a: BMK 750/1000 Power Box Internal Components**



**Figure 2-10b: BMK 1500/2000 Power Box Internal Components**

SECTION 2 – INSTALLATION



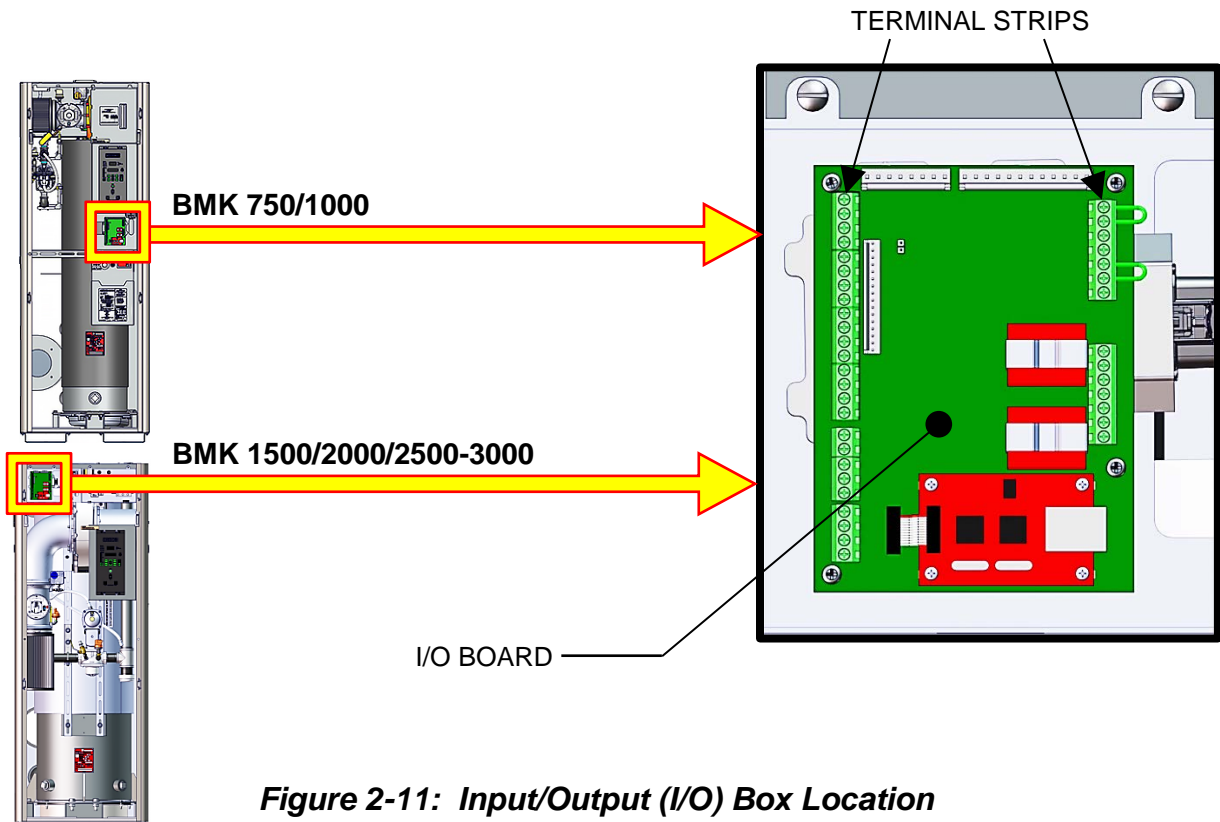
**Figure 2-10c: BMK 2500/3000 Power Box Internal Components**

NOTES:

- With the exception of the transformer shown in Figure 2-10a 2-10b, and 2-10c, all of the components in the Power Box are mounted on a DIN rail.
- All electrical conduit and hardware must be installed so that it does not interfere with the removal of any unit covers, inhibit service/maintenance, or prevent access between the unit and walls or another unit.

## 2.11 FIELD CONTROL WIRING

Each unit is fully wired from the factory with an internal operating control system. No field control wiring is required for normal operation. However, the C-More Controller used with all Benchmark units does allow for some additional control and monitoring features. Wiring connections for these features are made on the Input/Output (I/O) board located behind the removable front panel assembly of the unit. The location of the I/O board is shown in Figure 2-11. The I/O board terminal strip connections are shown in Figure 2-12. All field wiring is installed from the rear of the panel by routing the wires through one of the four bushings provided on the sides of the I/O board.



**Figure 2-11: Input/Output (I/O) Box Location**

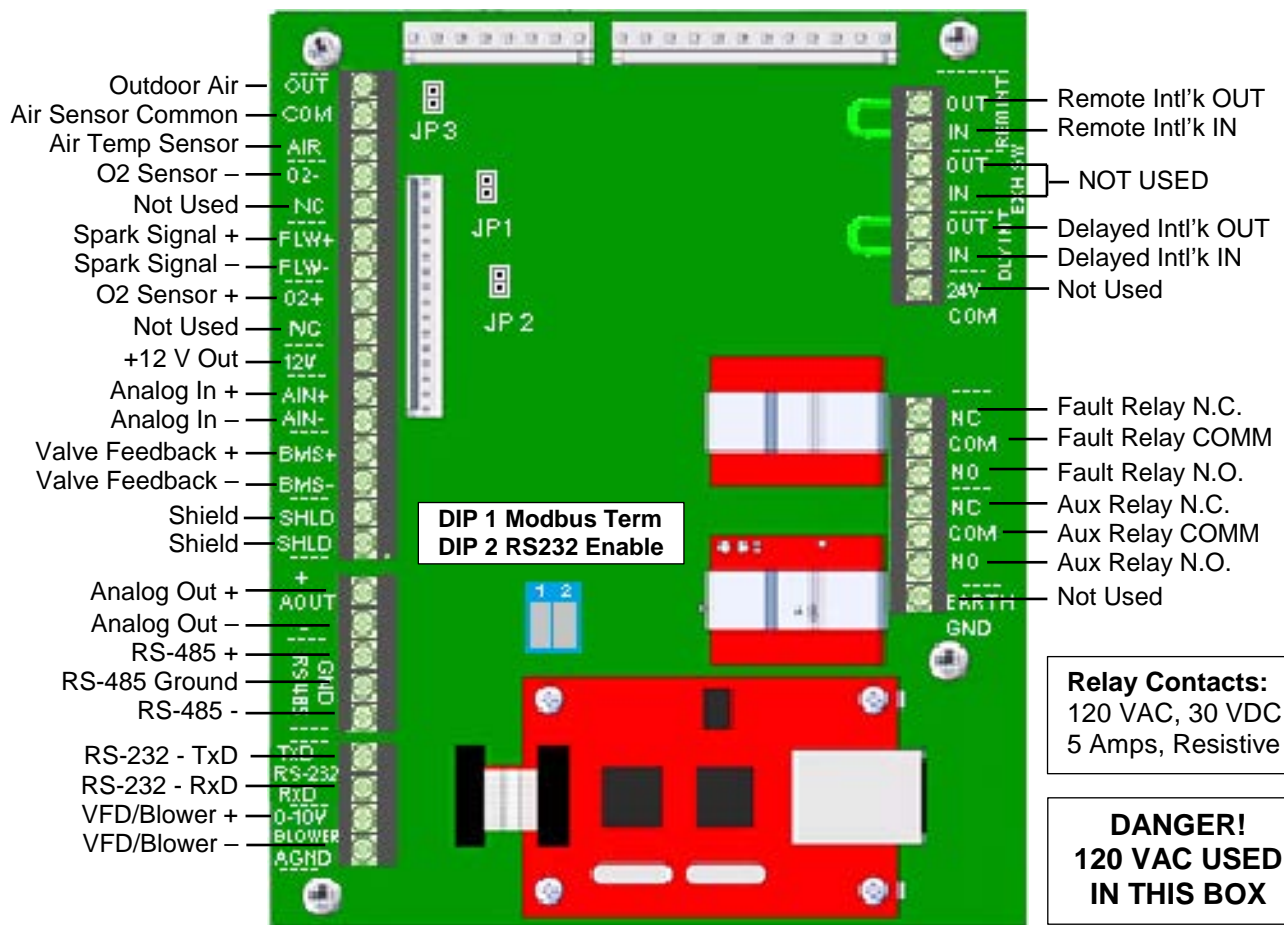
**NOTE:**

Use Figure 2-12 to determine the functions of the I/O board connections. Do not use the silkscreened label on the I/O board itself, as some labels may not match the functions. There is also a diagram of the connection functions on the cover of the I/O Box.

**WARNING!**  
DO NOT make any connections to the I/O Box terminals labeled **“NOT USED”**. Attempting to do so may cause equipment damage.



SECTION 2 – INSTALLATION



**NOTE:**  
Refer to this image for connections rather than the silkscreen labels shown on the board.

**Figure 2-12: I/O Box Terminal Strips**

**2.11.1 Outdoor Air & Air Sensor Common**

An outdoor temperature sensor (P/N **61047**) is required for the INDOOR/OUTDOOR RESET mode of operation. It can also be used with another mode if it is desired to use the outdoor sensor enable/disable feature, which allows the boiler to be enabled or disabled based on the outdoor air temperature.

The factory default for the outdoor sensor is DISABLED. To enable the sensor and/or select an enable/disable outdoor temperature, see Section 2.6: *CONFIGURATION Menu*, item 7, in the *Benchmark PLATINUM 750 – 3000 Operation and Maintenance Guide*, OMM-0116 (GF-201).

The outdoor sensor may be wired **up to 200 feet (61m)** from the boiler. It is connected to the **OUTDOOR AIR** and **AIR SENSOR COMMON** terminals of the I/O board (Figure 2-12). Wire the sensor using a twisted shielded pair wire from 18 to 22 AWG. There is no polarity to observe when terminating these wires. The shield is to be connected only to the terminals labeled *SHIELD* in the I/O Box PCB. The sensor end of the shield must be left free and ungrounded.

When mounting the sensor, it must be located on the North side of the building where an average outside air temperature is expected. The sensor must be shielded from direct sunlight as well as impingement by the elements. If a shield is used, it must allow for free air circulation.



### 2.11.2 AIR TEMP SENSOR

The **AIR TEMP SENSOR** terminal is used to monitor the air inlet temperature sensor (P/N **61024**). This input is always enabled and is a “view only” input. It can be seen in the AIR TEMP setting in the *Operating* menu (see Section 2.4: *OPERATING Menu*, item 4, of the *Benchmark PLATINUM 750 – 3000 Operation and Maintenance Guide*, OMM-0116 (GF-201)). A resistance chart for this sensor is provided in APPENDIX C of the same guide. This sensor is an active part of the combustion control system and must be operational for accurate air/fuel mixing control.

### 2.11.3 O<sub>2</sub> SENSOR (+ & –)

The two **O<sub>2</sub> SENSOR** terminals (+ and –) are used to connect an integrated oxygen sensor to the I/O board. The O<sub>2</sub> concentration is displayed in the *Operating* menu after a 60 second warm-up period. See Section 2.4: *OPERATING Menu*, item 13, of the *Benchmark PLATINUM 750 – 3000 Operation and Maintenance Guide*, OMM-0116 (GF-201).

### 2.11.4 SPARK SIGNAL (+ & –)

The two **SPARK SIGNAL** terminals (+ & -) connect to the spark monitor (P/N **61034**, also called "AC Current transducer"), which monitors the current going to the ignition transformer (P/N **65085**). See Section 5.12 in the *Benchmark PLATINUM 750 – 3000 Operation and Maintenance Guide*, OMM-0116 (GF-201) for more information. If the current is insufficient (too high or low) during the ignition sequence, the controller will abort the ignition cycle. The controller will attempt up to three ignition cycles. If the current is insufficient by the third try, the controller will shut down and display a fault message.

### 2.11.5 ANALOG IN

The two **ANALOG IN** terminals (+ and –) are used when an external signal is used to change the setpoint (REMOTE SETPOINT mode) of the boiler.

Either a **4 to 20 mA/1 – 5 VDC** or a **0 to 20 mA/0 – 5 VDC** signal may be used to vary the setpoint or air/fuel valve position. The factory default setting is **4 to 20 mA/1 – 5 VDC**, however this may be changed to **0 to 20 mA/0 – 5 VDC** in the *Configuration* menu; see Section 2.6: *CONFIGURATION Menu*, item 6, in the *Benchmark PLATINUM 750 – 3000 Operation and Maintenance Guide*, OMM-0116 (GF-201).

If voltage rather than current is selected as the drive signal, a DIP switch must be set on the PMC Board located inside the C-More Controller. Contact the AERCO factory for information on setting DIP switches.

All supplied signals must be floating (ungrounded) signals. Connections between the source and the boiler's I/O board (Figure 2-12) must be made using twisted shielded pair of 18–22 AWG wire such as Belden 9841. Polarity must be maintained and the shield must be connected only at the source end and must be left floating (not connected) at the Boiler's I/O board.

Whether using voltage or current for the drive signal, they are linearly mapped to a 40°F to 240°F (4.4 to 116 °C) setpoint or a 0% to 100% air/fuel valve position. No scaling for these signals is provided

### 2.11.6 VALVE FEEDBACK

The two **VALVE FEEDBACK** terminals (+ and –) are used when the Sequencing Isolation Valve Feedback option is selected. The Valve Feedback signal is connected to the “Valve Fdbk” terminals and is used to confirm that the valve has properly opened or closed. If the Valve

## SECTION 2 – INSTALLATION

Feedback signal does not match the Valve-Open or Valve-Close command for the time defined in the "Valve Fdbk timer" entry, the controller will proceed as follows:

- (a) If the valve fails with the Valve Stuck Open fault, the "Valve Stuck Open" message will be displayed and the unit will remain active.
- (b) If the valve fails with the Valve Stuck Closed fault, the "Valve Stuck Closed" message will be displayed and the unit will shut down.

**NOTE:**

If the Valve Feedback option is used, Shorting Jumper **MUST** be inserted on JP2 on the I/O Board (see Figure 2-12).

**2.11.7 SHIELD (SHLD & SHLD)**

The SHIELD terminals are used to terminate any shields used on sensor wires connected to the unit. Shields must only be connected to these terminals.

**2.11.8 ANALOG OUT**

The two **ANALOG OUT** terminals (+ & -) output from 0 to 20 mA and may be used to monitor Setpoint, Outlet Temperature, Valve Position 4-20 mA, Valve Position 0-10v or be set to OFF. The default setting in the C-More Controller is Valve Position 0-10v, and behaves as follows:

- 0-10VDC **must** be selected for the voltage output used by the controller to modulate the combustion blower via the I/O Box terminals labeled **VFD/BLOWER** (Section 2.11.11).
- If Boiler Sequencing Technology (BST) is enabled, the Analog Output terminals are used to drive the isolation valve, open and closed. A 0-20 mA signal is used, with 20 mA to close the valve and 0 to open.

**NOTE:**

When driving an isolation valve, shorting jumper #JP2 **MUST** be installed on the I/O Board.

**2.11.9 RS485 Comm (+, GND, & -)**

The three **RS-485** communication terminals are used when the boiler plant is being controlled by an Energy Management System (EMS) or an AERCO Control System (ACS) using Modbus (RS485) communication.

**2.11.10 RS232 Comm (TxD & RxD)**

As of Firmware version 4.0 and above, these terminals are used only by factory-trained personnel to monitor onAER communications via a portable computer.

**2.11.11 VFD/Blower (0-10 & AGND)**

The two **VFD/BLOWER** (0-10 & AGND) terminals send an analog signal to control the blower speed.

## 2.11.12 Interlocks

The unit has two interlock circuits for interfacing with Energy Management Systems and auxiliary equipment such as pumps, louvers or other accessories. These interlocks are called the Remote Interlock and Delayed Interlock (**REMOTE INTL’K IN** and **DELAYED INTL’K IN** in Figure 2-12). Both interlocks, described below, are factory wired in the closed position using jumpers.

### NOTE:

Both the Delayed Interlock and Remote Interlock must be in the closed position for the unit to fire.

### 2.11.12.1 Remote Interlock In (OUT & IN)

The remote interlock circuit is provided to remotely start (enable) and stop (disable) the unit if desired. The circuit is 24 VAC and comes factory pre-wired closed (jumped).

### 2.11.12.2 Delayed Interlock In (OUT & IN)

The Delayed Interlock terminals can be used in one of two ways:

- In conjunction with the optional external sequencing valve (see section 2.15: *Sequencing Isolation Valve Installation* and Section 6: *BST*), a component of AERCO’s on-board Boiler Sequencing Technology (BST) solution. A cable of the boiler’s wiring harness is connected to these terminals on all units; if BST is implemented, the other end of that cable is connected to the sequencing valve.
- If BST is *NOT* implemented, the second use is typically in conjunction with the AUXILIARY RELAY CONTACTS described in section 2.11.14, below. This interlock circuit is located in the purge section of the start string. It can be connected to the proving device (end switch, flow switch etc.) of an auxiliary piece of equipment started by the unit’s auxiliary relay. If the delayed interlock is connected to a proving device that requires time to close (make), a time delay (AUX START ON DLY) that holds the start sequence of the unit long enough for a proving switch to make (close) can be programmed.

To use this option, you must disconnect the harness from the Delayed Interlock terminals and connect the proving device in its place.

Should the proving switch not prove within the programmed time frame, the unit will shut down. The AUX START ON DLY can be programmed from 0 to 120 seconds. This option is located in the *Configuration* menu (see Section 2.6: *CONFIGURATION Menu*, item 16, in the *Benchmark PLATINUM 750 – 3000 Operation and Maintenance Guide*, OMM-0116 (GF-201)).

## 2.11.13 Fault Relay (NC, COM, & NO)

The fault relay is a single pole double throw (SPDT) relay having a normally open and normally closed set of relay contacts that are rated for 5 amps at 120 VAC and 5 amps at 30 VDC. The relay energizes when any fault condition occurs and remains energized until the fault is cleared and the **CLEAR** button is depressed.

## 2.11.14 Auxiliary Relay Contacts (NC, COM, & NO)

Each unit is equipped with a single pole double throw (SPDT) relay that is energized when there is a demand for heat and de-energized after the demand for heat is satisfied. The relay is provided for the control of auxiliary equipment, such as pumps and louvers, or can be used as a

## SECTION 2 – INSTALLATION

unit status indicator (firing or not firing). Its contacts are rated for 120 VAC @ 5 amps. Refer to Figure 2-12 to locate the AUXILIARY RELAY terminals for wiring connections.

## 2.12 FLUE GAS VENT INSTALLATION

AERCO's *Benchmark Venting and Combustion Air Guide*, TAG-0022 (GF-2050) must be consulted before any flue or combustion air venting is designed or installed. Suitable, U/L approved, positive pressure, watertight vent materials **MUST** be used for safety and UL certification. Because the unit is capable of discharging low temperature exhaust gases, **the flue must be pitched back towards the unit a minimum of 1/4" per foot (0.64 cm per 0.3 m)** to avoid any condensate pooling and to allow for proper drainage.

While there is a positive flue pressure during operation, the combined pressure drop of vent and combustion air systems **must not exceed 140 equivalent feet (42.7m) or 0.8" W.C. (199 Pa)**. Fittings as well as pipe lengths must be calculated as part of the equivalent length. For a natural draft installation **the draft must not exceed -0.25" W.C. (-62 Pa)**. These factors must be planned into the vent installation. If the maximum allowable equivalent lengths of piping are exceeded, the unit will not operate properly or reliably.

### 2.12.1 MASSACHUSETTS INSTALLATIONS

For Massachusetts installations, the following companies provide vent systems which conform to all applicable requirements for installations within the Commonwealth of Massachusetts. Contact information is as follows:

**Selkirk Corporation - Heatfab Division**

130 Industrial Blvd.  
Turners Falls, MA 01376  
Phone: 1-800-772-0739  
[www.heatfab.com](http://www.heatfab.com)

**Watertown Supply**

33 Grove St.  
Watertown, MA 02472  
Phone: (617) 924-2840  
[www.watertownsupply.com/](http://www.watertownsupply.com/)

**Glover Sheet Metal, Inc.**

44 Riverdale Ave.  
Newton, MA 02485  
Phone: (617) 527-8178  
[www.gloversheetmetal.com](http://www.gloversheetmetal.com)

## 2.13 COMBUSTION AIR

The *Benchmark Venting and Combustion Air Guide*, TAG-0022 (GF-2050) MUST be consulted before any inlet air venting is designed or installed. Air supply is a direct requirement of ANSI 223.1, NFPA-54, CSA B149.1 and local codes. These codes should be consulted before a permanent design is determined.

The combustion air must be free of chlorine, halogenated hydrocarbons or other chemicals that can become hazardous when used in gas-fired equipment. Common sources of these compounds are swimming pools, degreasing compounds, plastic processing, and refrigerants. Whenever the environment contains these types of chemicals, combustion air MUST be supplied from a clean area outdoors for the protection and longevity of the equipment and warranty validation.

If combustion air is supplied directly to the unit(s) though air duct(s), see section 2.13.1 below.

If combustion air is not supplied through air ducts, it must be supplied to the unit(s) through two permanent openings. These two openings must have a free area of **not less than one square inch (6.5 cm<sup>2</sup>) for each 4000 BTUs (1.17 kW) input for each unit**. The free area must take into account restrictions such as louvers and bird screens. For Canada installations, refer to the requirements specified in CSA B149.1-10, sections 8.4.1 and 8.4.3.

### 2.13.1 DUCTED COMBUSTION AIR

For ducted combustion air installations, the air ductwork must be attached directly to the air inlet connection on the sheet metal enclosure. Consult the *Benchmark Venting and Combustion Air Guide*, TAG-0022 (GF-2050) when designing combustion air ducting.

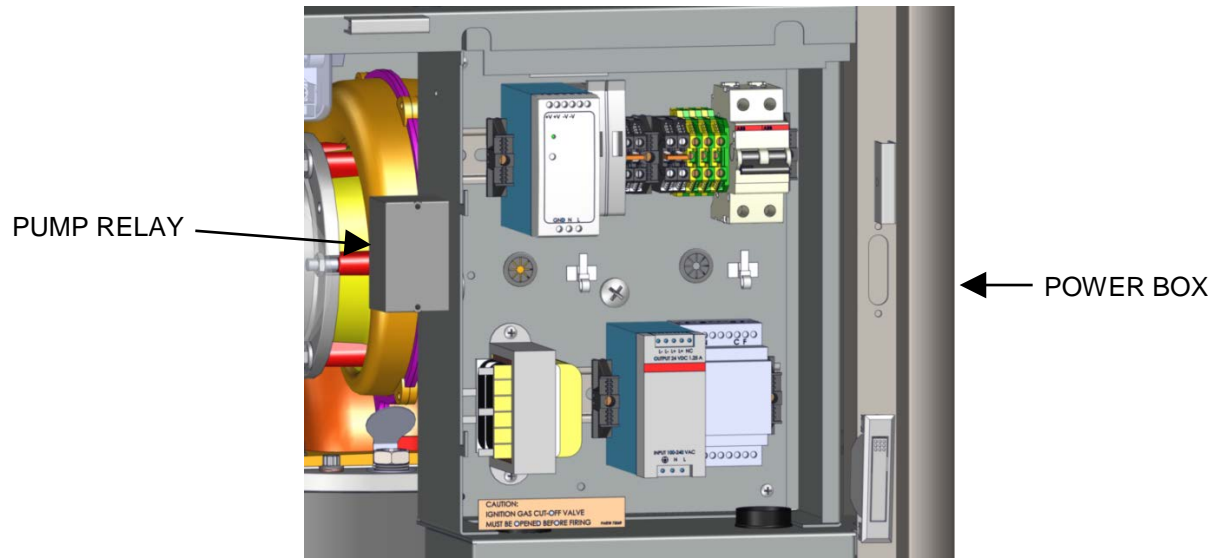
In a ducted combustion air application, the combustion air ducting pressure losses must be taken into account when calculating the total maximum allowable venting run. When using the unit in a ducted combustion air configuration, the minimum diameter connection at the unit is:

TABLE 2-4: Air Duct Minimum Diameter	
Benchmark Model	Duct Diameter
BMK 750 BMK 1000 BMK 1500	6 inch (15.2 cm) diameter connection
BMK 2000 BMK 2500 BMK 3000	8 inch (20.3 cm) diameter connection

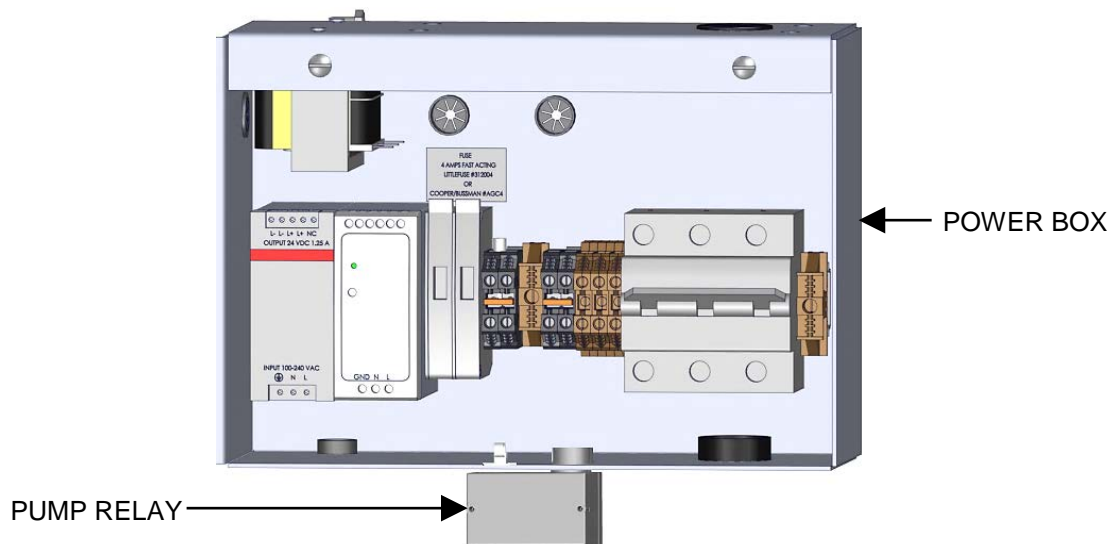
## 2.14 BENCHMARK PUMP RELAY

All Benchmark Platinum models ship with a pump relay (P/N **69102-2** for BMK750/1000, **69102-3** for BMK1500-3000) as standard equipment. The pump relay allows the user to turn a pump on/off and open/close a motorized valve as the boiler cycles on and off on demand. The Pump Delay Timer feature allows the user to keep the pump running and keep the motorized valve open for up to 30 minutes after the boiler has shut down and the demand is satisfied.

The pump relay is attached to the outside of the power box, as shown below. Boilers equipped with the pump relay have a label on the power box cover adjacent to the relay.



**Figure 2-13a: BMK 750/1000 Pump Relay Location**

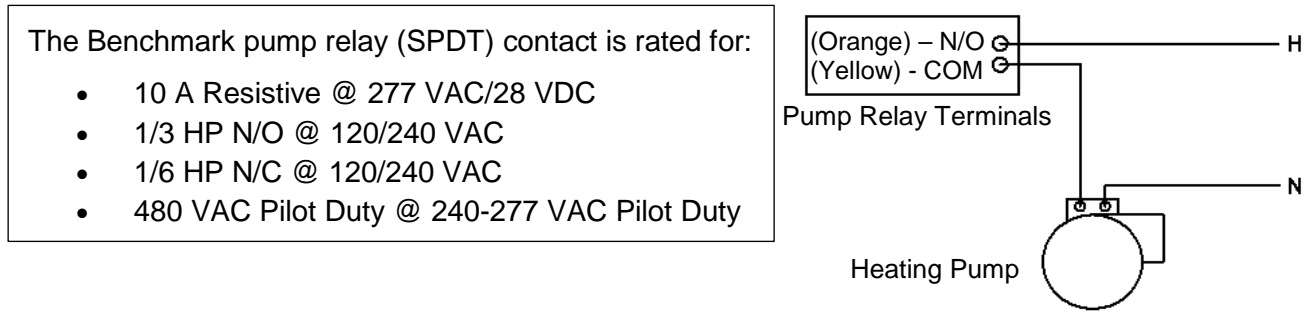


**Figure 2-13b: BMK 1500/2000/2500-3000 Pump Relay Location (BMK 25000/3000 Shown)**



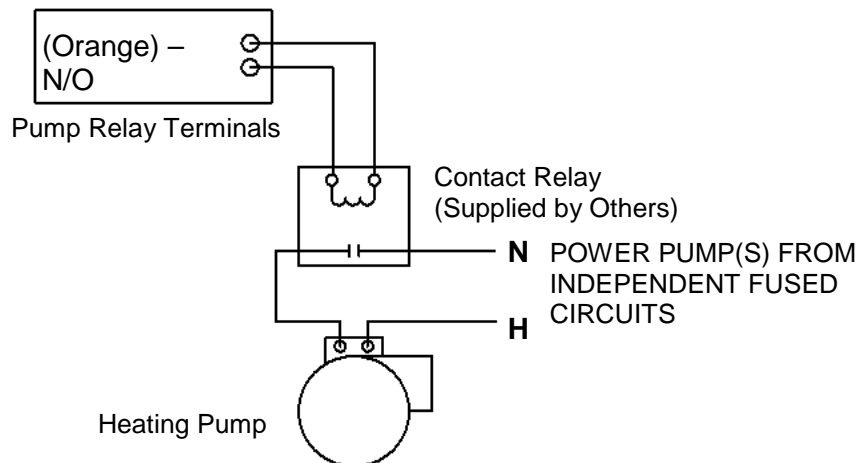
SECTION 2 – INSTALLATION

See Figures 2-14 and 2-15 for wiring details.



**Figure 2-14: Schematic – System Pump Start using Boiler Pump Relay**

If pump/valve load exceeds the above contact ratings, use a separate contact relay, as shown in Figure 2-15.



**Figure 2-15: Schematic – System Pump Start using a Separate Contact Relay**

## 2.15 SEQUENCING ISOLATION VALVE INSTALLATION

All Benchmark units are pre-wired with a connection for an optional motorized external sequencing isolation valve (P/N **92084-TAB**). This valve is an integral component of the AERCO’s on-board Boiler Sequencing Technology (BST) solution. BST allows sites with multiple boilers to have one boiler, acting as a “Manager” to manage the other boilers at the site, designated as “Clients” in such a way that the efficiency of the entire boiler array is maximized.

When operated with the BST system, the Manager controls its own isolation valve and sends signals to the Client units to open or close their isolation valves. After the boiler load is satisfied, the isolation valve opens for a programmed interval (default = 1 minute) before closing. When the system load is satisfied, the BST system will open the isolation valves for all of the boilers.

The implementation of BST, and the installation and use of this valve is optional. However, **when BST is implemented, use of this valve is strongly recommended.**

Installation consists of installing the sequencing isolation valve in the hot water outlet pipe, and then connecting it to the pre-wired connector on the shell harness, as described below.

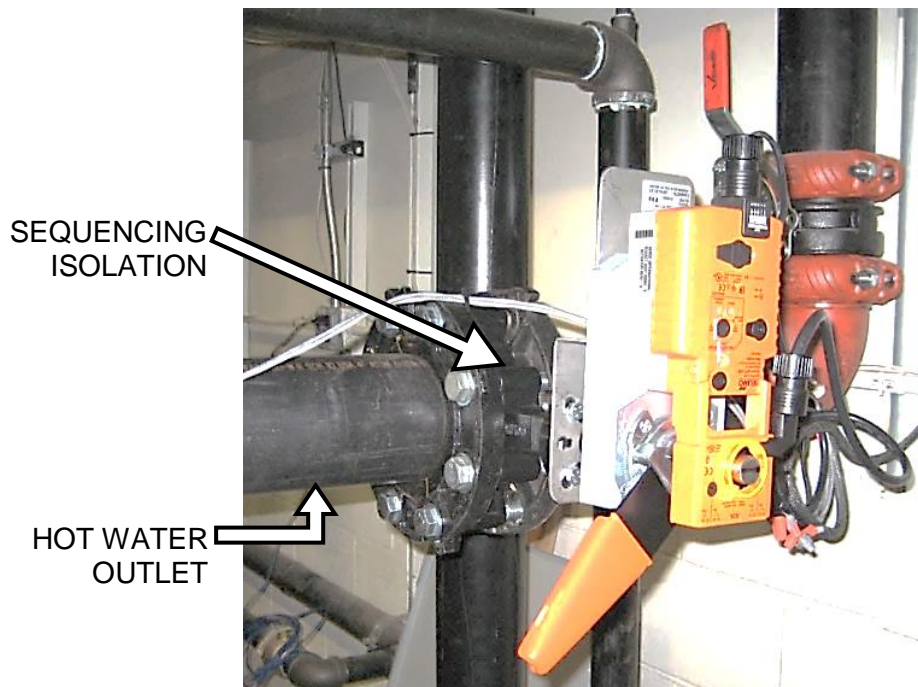


**NOTE:**

When the Sequencing Isolation Valve is used, the AUX START ON DLY in the *Configuration* menu must be set to 120 seconds (see Section 2.6: *CONFIGURATION Menu*, item 16, in the *Benchmark PLATINUM 750 – 3000 Operation and Maintenance Guide*, OMM-0116 (GF-201)). The Sequencing Isolation Valve control is only available when BST is enabled. Refer to section 2.11.12.2 (wiring) and Section 6: *Boiler Sequencing Technology* in this guide, and Section 2.6: *CONFIGURATION Menu* in the *Benchmark PLATINUM 750 – 3000 Operation and Maintenance Guide*, OMM-0116 (GF-201).

**Sequencing Isolation Valve Installation Instructions**

1. Install the sequencing isolation valve in the boiler's hot water outlet pipe (Figure 2-16).



**Figure 2-16: Sequencing Isolation Valve Installed**

2. Find the unused black cable, coiled inside the unit's enclosure. One end is connected to the DELAYED INTERLOCK IN terminals in the I/O board, while the other end contains a Molex connector with a cap containing a jumper wire inserted in it (this jumper wire allows units that do not have a sequencing isolation valve to operate normally).
3. Remove the cap (with jumper wire attached) from the Molex connector and dispose of it.



**Figure 2-17: Sequencing Isolation Valve Molex Connector and Jumper Wire**

4. Plug the Molex connector into the sequencing isolation valve's connector.

## SECTION 3: START SEQUENCE

### 3.1 INTRODUCTION

The information in this Section provides a guide to starting the Benchmark Boiler using the C-More Controller mounted on the front of the unit. It is imperative that the initial startup of this unit be performed by factory trained personnel. Operation prior to initial startup by factory trained personnel may void the equipment warranty. In addition, the following WARNINGS and CAUTIONS must be observed at all times.

#### WARNING!

- Electrical voltages in this system include 120 VAC (BMK 750 – 20000) or 208 or 460 VAC (BMK 2500/3000) and 24 volts AC. It must be serviced only by factory certified service technicians.
- **Do not attempt to dry fire the unit.** Starting the unit without a full water level can seriously damage the unit and may result in injury to personnel or property damage. This situation will void any warranty.

#### CAUTION!

All of the installation procedures in Section 2 must be completed before attempting to start the unit.

### 3.2 START SEQUENCE

When the C-more Controller ON/OFF switch is set to the **ON** position, it checks all pre-purge safety switches to ensure they are closed. These switches include:

- Safety Shut-Off Valve (SSOV) Proof of Closure (POC) switch
- Low Water Level switch
- High Water Temperature switch
- High Gas Pressure switch
- Low Gas Pressure switch

#### NOTE:

The **Blocked Inlet** and downstream **Blower Proof** switches are *not* checked prior to starting the pre-purge.

If all of the above switches are closed, the READY light above the ON/OFF switch will light and the unit will be in the STANDBY mode.

#### NOTE:

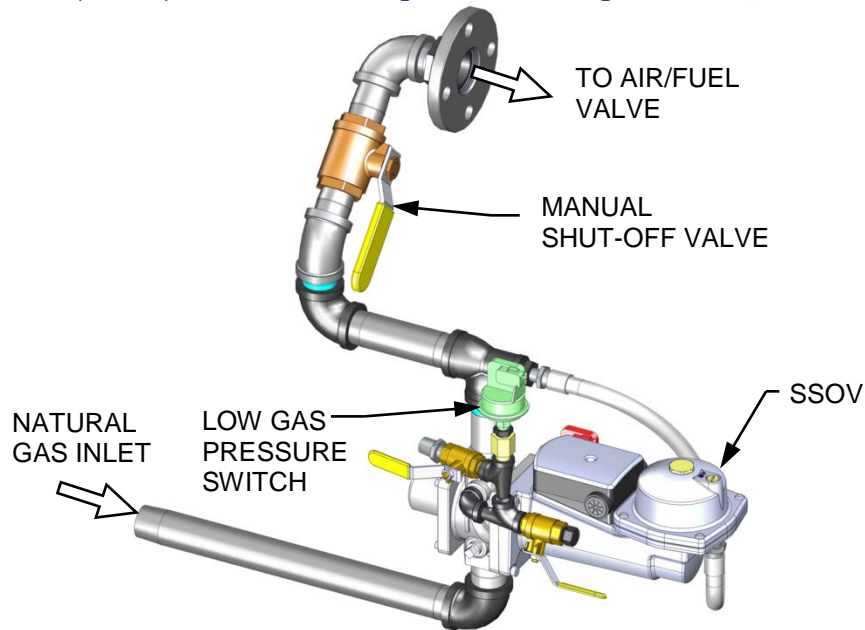
If any of the Pre-Purge safety device switches are open, the appropriate fault message will be displayed. Also, the appropriate messages will be displayed throughout the start sequence, if the required conditions are not observed

SECTION 3 - START SEQUENCE

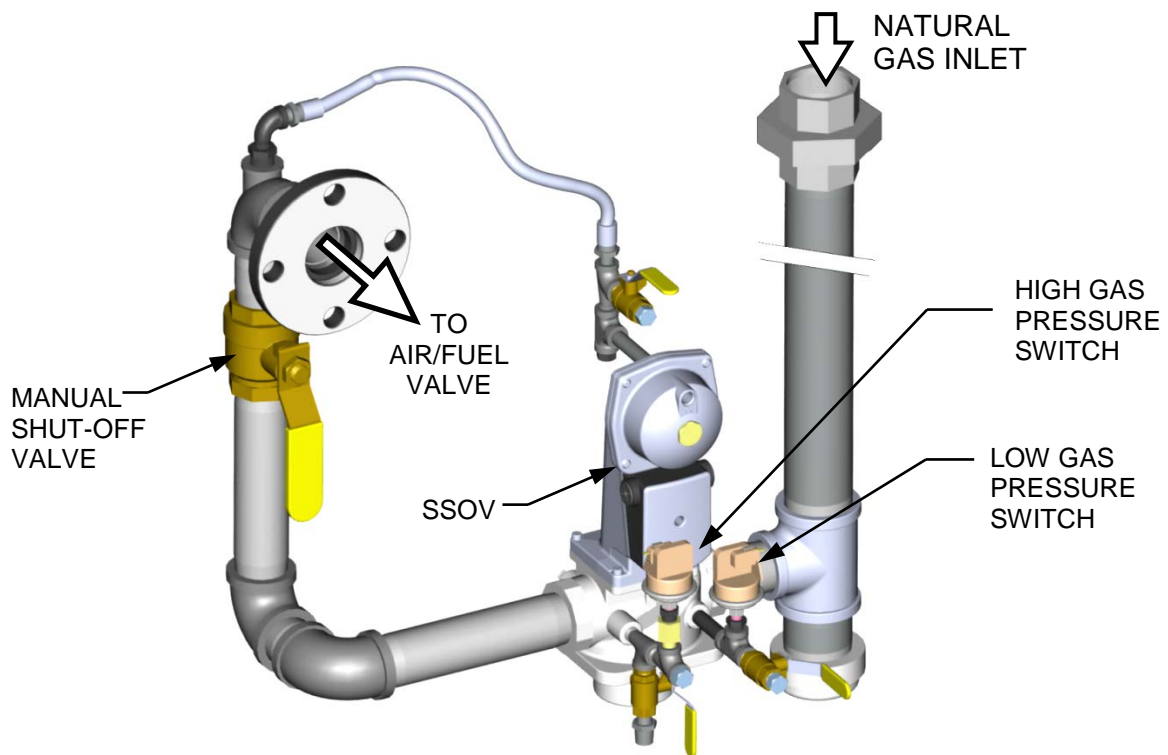
When there is a demand for heat, the following events will occur:

**Start Sequence:**

1. The **DEMAND** LED status indicator will light.
2. The unit checks to ensure that the Proof of Closure (POC) switch in the downstream Safety Shut-Off Valve (SSOV) is closed. See Figure 3-1a through 3-1d for SSOV location.

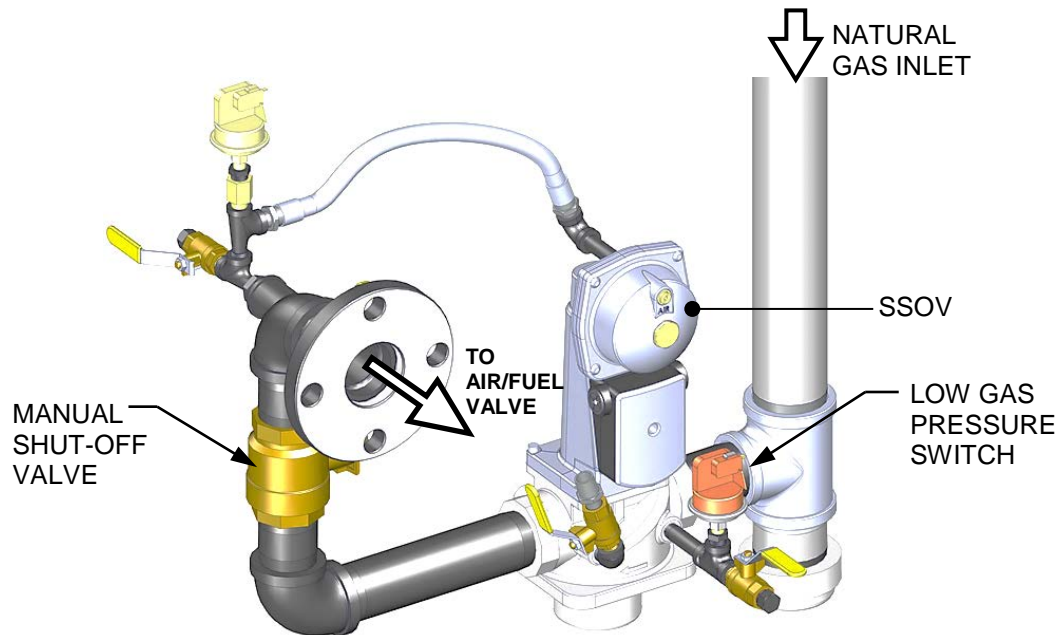


**Figure 3-1a: BMK 750 & 1000 SSOV Location (P/N 22140-1 shown)**

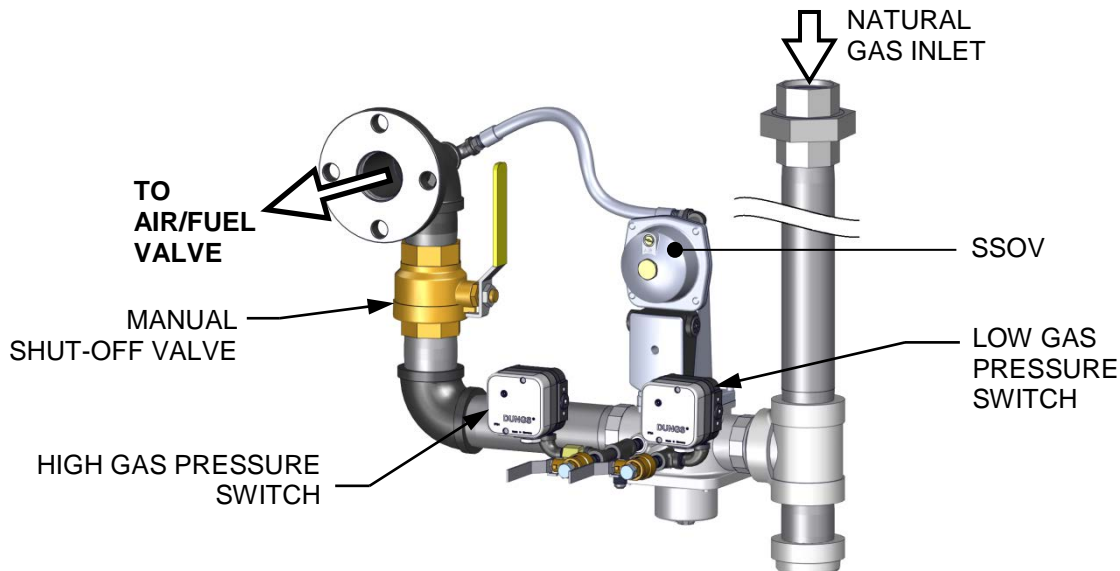


**Figure 3-1b: BMK 1500 & 2000 SSOV Location (P/N 22188 shown)**

**Start Sequence:**



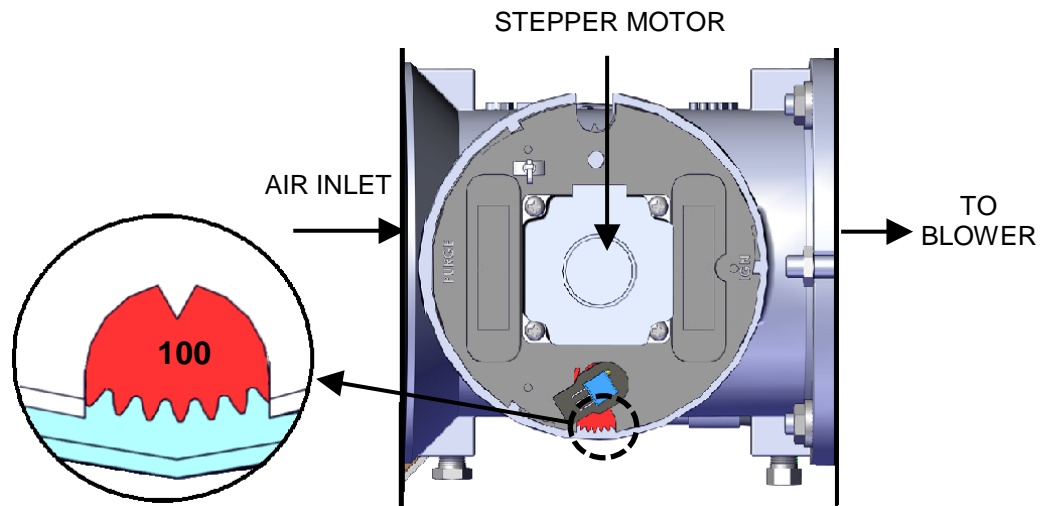
**Figure 3-1c: BMK 2500: SSOV Location (P/N 22190 shown)**



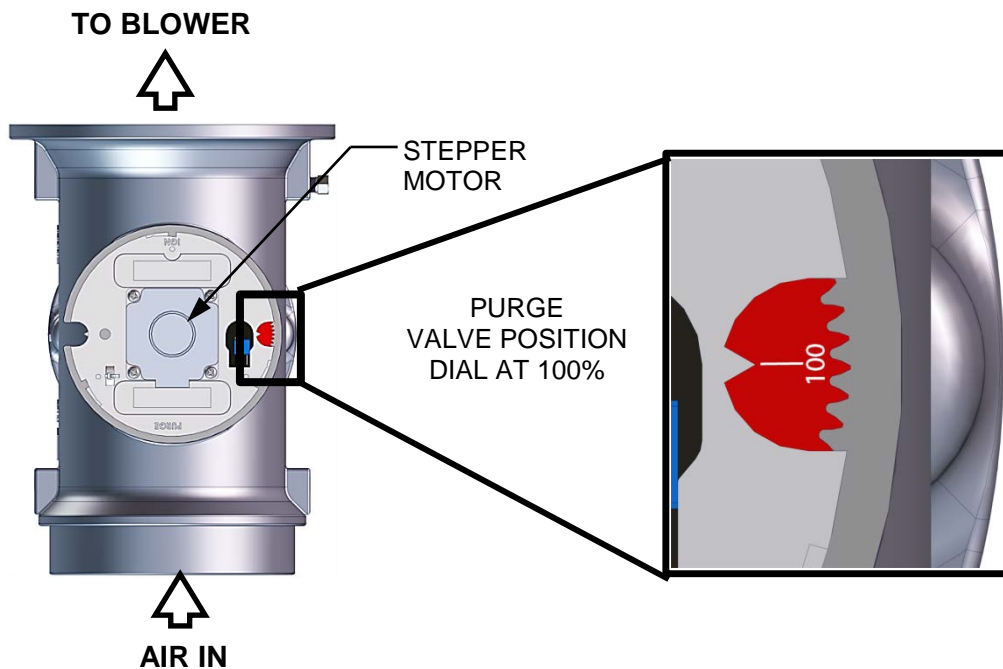
**Figure 3-1d: BMK 3000: SSOV Location (P/N 22171 shown)**

3. With all required safety device switches closed, a purge cycle will be initiated and the following events will occur:
  - a. The Blower relay energizes and turns on the blower.
  - b. The Air/Fuel Valve rotates to the full-open purge position and closes purge position switch. The dial on the Air/Fuel Valve (Figure 3-2a and 3-2b) will read **100** to indicate that it is full-open (100%).
  - c. The **VALVE POSITION** bargraph will show 100%.

**Start Sequence:**



*Figure 3-2a: BMK 750 & 1000 Air/Fuel Valve in Purge Position*

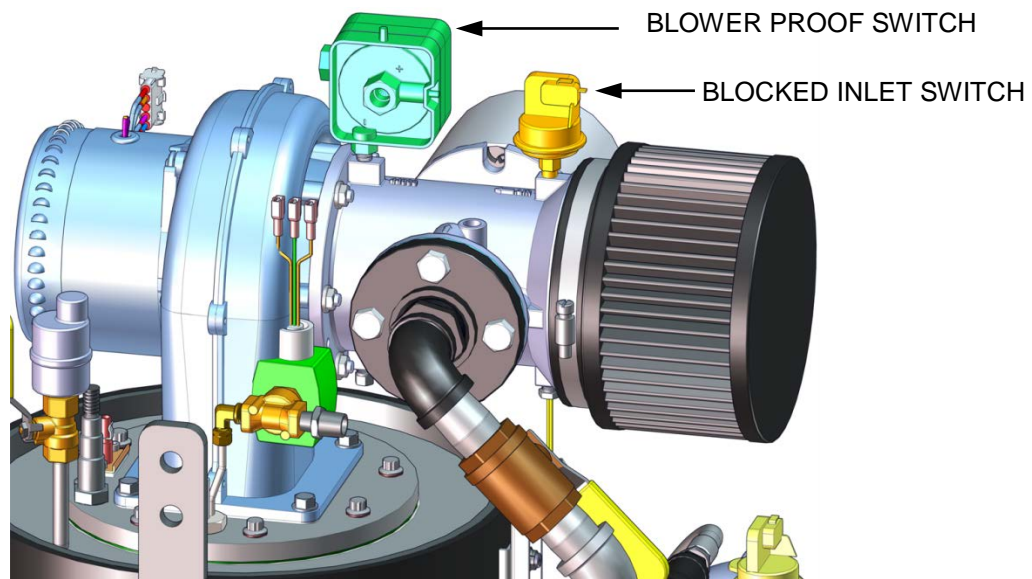


*Figure 3-2b: BMK 1500 – 3000 Air/Fuel Valve In Purge Position*

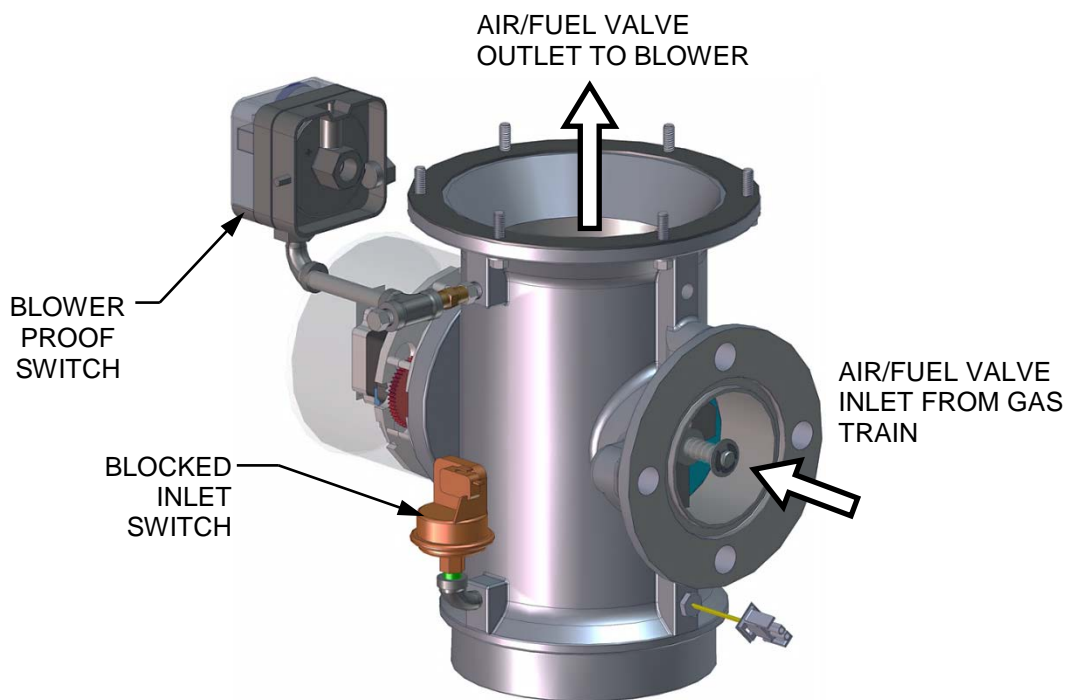
4. Next, the blower proof switch on the Air/Fuel Valve (Figure 3-3a and 3-3b) closes. The display will show **PURGING** and indicate the elapsed time of the purge cycle in seconds.



**Start Sequence:**



**Figure 3-3a: BMK 750 & 1000 Blower Proof Switch**

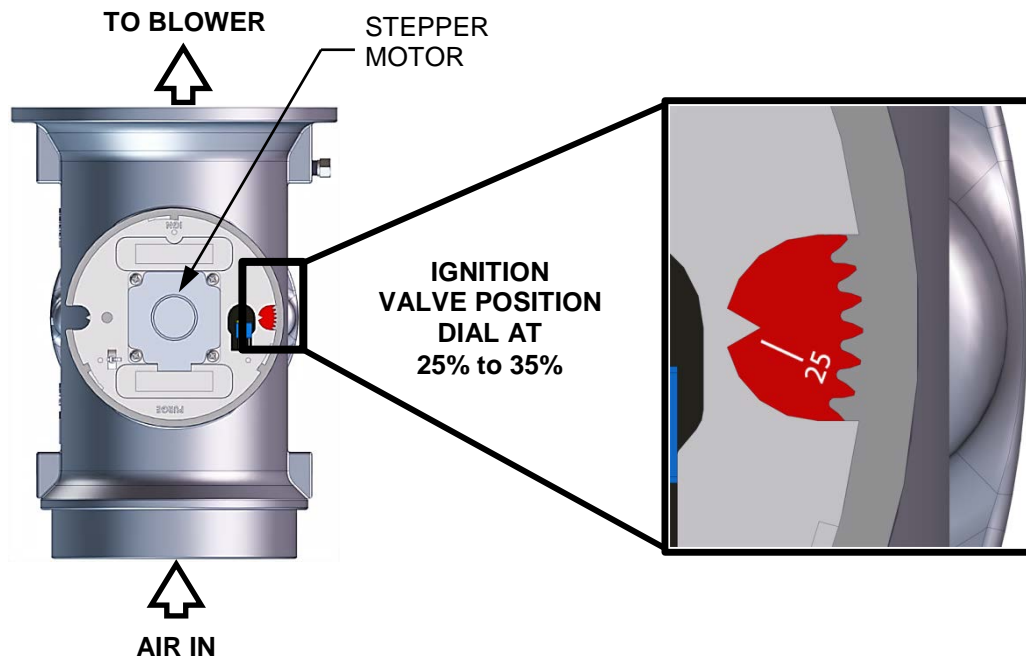


**Figure 3-3b: BMK 1500 – 3000 Blower Proof Switch**

5. Upon completion of the purge cycle, the C-More Controller initiates an ignition cycle and the following events occur:
  - a) The Air/Fuel Valve rotates to the low-fire (Ignition Position) position and closes the ignition switch. The Dial on the Air/Fuel Valve (Figure 3-4) will read between **25** and **35** to indicate that the valve is in the low fire position.

### Start Sequence:

- b) The “Spark Cycle Time” item in the *Factory* menu can be set to either 0 Sec, 2 Sec or 7 Sec to define the duration of the Spark Element Cleaning Cycle. This cycle turns on the spark transformer to produce a spark (with no gas flowing) to clean the spark element of moisture or carbon buildup.
- c) For the duration of this cycle, the C-More Controller will display the **CLEANING IGNITER** message.
- d) Following the Spark Element Cleaning Cycle, power is applied to the Gas Safety Shut-off Valve (SSOV) and the C-More Controller displays the **PRE IGNITION** message. When the SSOV indicates the Gas Valve is OPEN (POC), the C-More Controller displays the **IGNITION TRIAL** message.
- e) If no spark is present 3 seconds into the IGNITION TRIAL, the C-More Controller will abort the Ignition Cycle and shut down the boiler. Refer to Section 6: *Troubleshooting Guide* in the *Benchmark PLATINUM 750 – 3000 Operation and Maintenance Guide*, OMM-0116 (GF-201) for guidance if this occurs.



**Figure 3-4: Air/Fuel Valve In Ignition Position**

6. Up to 4 seconds will be allowed for ignition to be detected. The igniter relay will be turned off one second after flame is detected.
7. After 2 seconds of continuous flame, **FLAME PROVEN** will be displayed and the flame strength will be indicated. After 5 seconds, the current date and time will be displayed in place of the flame strength.
8. With the unit firing properly, it will be controlled by the temperature controller circuitry. The boiler’s **VALVE POSITION** will be continuously displayed on the front panel bargraph.
9. Once the demand for heat has been satisfied, the C-More Controller will turn off the SSOV gas valve. The blower relay will be deactivated and the Air/Fuel Valve will be closed. **STANDBY** will be displayed.



### 3.3 START/STOP LEVELS

The start and stop levels are the Air/Fuel Valve positions (% open) that start and stop the unit, based on load. These levels are Factory preset as follows:

<b>TABLE 3-1a: Start/Stop Levels – NATURAL GAS</b>						
	<b>BMK 750</b>	<b>BMK 1000</b>	<b>BMK 1500</b>	<b>BMK 2000</b>	<b>BMK 2500</b>	<b>BMK 3000</b>
<b>Start Level:</b>	22%	22%	24%	24%	24%	20%
<b>Stop Level:</b>	18%	18%	16%	18%	16%	14%

<b>TABLE 3-1b: Start/Stop Levels – PROPANE GAS</b>						
	<b>BMK 750</b>	<b>BMK 1000</b>	<b>BMK 1500</b>	<b>BMK 2000</b>	<b>BMK 2500</b>	<b>BMK 3000</b>
<b>Start Level:</b>	22%	22%	24%	24%	26%	22%
<b>Stop Level:</b>	18%	18%	18%	18%	18%	14%

Normally, these settings do not require adjustment.

Note that the energy input of the boiler is not linearly related to the Air/Fuel Valve position.

### 3.4 START/STOP LEVELS – AIR/FUEL & ENERGY INPUT

The Tables below show the relationship between the energy input and Air/Fuel Valve position for the BMK models covered in this document.

#### 3.4.1 BMK 750/1000 Air/Fuel Valve Position and Energy Input

**TABLE 3-2a: BMK 750/1000 Air/Fuel Valve Position – NATURAL GAS**

AIR/FUEL VALVE POSITION (% OPEN)	ENERGY INPUT (BTU/HR)		BOILER ENERGY INPUT (% OF FULL CAPACITY)	
	BMK 750	BMK 1000	BMK 750	BMK 1000
0%	0	0	0	0
10%	0	0	0	0
18% (Stop Level)	50,000 (14.7 kW)	50,000 (14.7 kW)	6.7%	5%
20%	52,000 (15.2 kW)	54,000 (15.8 kW)	6.9%	5.4%
30%	108,000 (31.7 kW)	140,000 (41.0 kW)	14%	14%
40%	246,000 (72.1 kW)	297,000 (87.0 kW)	33%	30%
50%	369,000 (108.1 kW)	443,000 (126.9 kW)	49%	44%
60%	465,000 (136.3 kW)	564,000 (165.3 kW)	62%	56%
70%	554,000 (162.4 kW)	660,000 (193.4 kW)	74%	66%
80%	637,000 (186.7 kW)	789,000 (231.2 kW)	85%	79%
90%	733,000 (214.8 kW)	933,000 (273.4 kW)	98%	93%
100%	750,000 (219.8 kW)	1,000,000 (293.1 kW)	100%	100%

**TABLE 3-2b: BMK 750/1000 Air/Fuel Valve Position – PROPANE GAS**

Air/Fuel Valve Position (% Open)	Energy Input (BTU/Hr)		Boiler Energy Input (% of Full Capacity)	
	BMK 750	BMK 1000	BMK 750	BMK 1000
0%	0	0	0	0
10%	0	0	0	0
18% (Stop Level)	50,000 (14.7 kW)	50,000 (14.7 kW)	6.7%	5.0%
20%	71,000 (20.8 kW)	71,000 (20.8 kW)	9.5%	7.1%
30%	128,000 (37.5 kW)	181,000 (53.0 kW)	17%	18%
40%	373,000 (109.3 kW)	400,000 (117.2 kW)	50%	40%
50%	508,000 (148.9 kW)	562,000 (164.7 kW)	68%	56%
60%	565,000 (165.6 kW)	703,000 (206.0 kW)	75%	70%
70%	621,000 (182.0 kW)	791,000 (231.8 kW)	83%	79%
80%	660,000 (193.4 kW)	865,000 (253.5 kW)	88%	87%
90%	723,000 (211.9 kW)	963,000 (282.2 kW)	96%	96%
100%	750,000 (219.8 kW)	1,000,000 (293.1 kW)	100%	100%

**3.4.2 BMK 1500 Air/Fuel Valve Position and Energy Input**

**TABLE 3-3a: BMK 1500 Air/Fuel Valve Position – NATURAL GAS**

AIR/FUEL VALVE POSITION (% OPEN)	ENERGY INPUT (BTU/HR)	BOILER ENERGY INPUT (% OF FULL CAPACITY)
16% (Stop Level)	76,000 (22.3 kW)	5.0%
20%	127,000 (37.2 kW)	8.5%
30%	366,000 (107.2 kW)	24.4%
40%	629,000 (184.3 kW)	41.9%
50%	822,000 (240.9 kW)	54.7%
60%	977,000 (286.2 kW)	65.0%
70%	1,119,000 (327.9 kW)	74.5%
80%	1,255,000 (367.7 kW)	83.5%
90%	1,396,000 (409.0 kW)	92.9%
100%	1,502,000 (440.1 kW)	100%

**TABLE 3-3b: BMK 1500 Air/Fuel Valve Position – PROPANE GAS**

AIR/FUEL VALVE POSITION (% OPEN)	ENERGY INPUT (BTU/HR)	BOILER ENERGY INPUT (% OF FULL CAPACITY)
18% (Stop Level)	75,000	5.0%
20%	93,700	6.2%
30%	254,000	16.9%
40%	505,000	33.7%
50%	680,000	45.3%
60%	807,000	53.8%
70%	947,000	63.1%
80%	1,157,000	77.1%
90%	1,379,000	91.9%
100%	1,503,000	100%

**3.4.3 BMK 2000 Air/Fuel Valve Position and Energy Input**

**TABLE 3-4a: BMK 2000 Air/Fuel Valve Position – NATURAL GAS**

AIR/FUEL VALVE POSITION (% OPEN)	ENERGY INPUT (BTU/HR)	BOILER ENERGY INPUT (% OF FULL CAPACITY)
18% (Stop Level)	100,000 (29.3 kW)	6.7%
20%	143,000 (41.9 kW)	11%
30%	388,000 (113.7 kW)	23%
40%	759,000 (222.4 kW)	37%
50%	1,069,000 (313.2 kW)	51%
60%	1,283,000 (375.9 kW)	61%
70%	1,476,000 (432.5 kW)	74%
80%	1,675,000 (490.1 kW)	83%
90%	1,833,000 (537.1 kW)	93%
100%	2,000,000 (586.0 kW)	100%

**TABLE 3-4b: BMK 2000 Air/Fuel Valve Position – PROPANE GAS**

AIR/FUEL VALVE POSITION (% OPEN)	ENERGY INPUT (BTU/HR)	BOILER ENERGY INPUT (% OF FULL CAPACITY)
18% (Stop Level)	100,000	5.0%
20%	126,600	6.3%
30%	363,000	18.2%
40%	677,000	33.9%
50%	898,000	44.9%
60%	1,070,000	53.5%
70%	1,242,000	62.1%
80%	1,523,000	76.2%
90%	1,845,000	92.3%
100%	2,000,000	100%

**3.4.4 BMK 2500 Air/Fuel Valve Position and Energy Input**

**TABLE 3-5a: BMK 2500 Air/Fuel Valve Position – NATURAL GAS**

AIR/FUEL VALVE POSITION (% OPEN)	ENERGY INPUT (BTU/HR)	BOILER ENERGY INPUT (% OF FULL CAPACITY)
16% (Stop Level)	167,000 (48.9 kW)	6.7%
30%	430,000 (126.0 kW)	17%
40%	770,000 (225.7 kW)	31%
50%	1,440,000 (422.0 kW)	43%
60%	1,820,000 (533.4 kW)	58%
70%	1,815,000 (531.9 kW)	73%
80%	2,030,000 (594.9 kW)	81%
90%	2,300,000 (674.1 kW)	92%
100%	2,500,000 (732.7 kW)	100%

**TABLE 3-5b: BMK 2500 Air/Fuel Valve Position – PROPANE GAS**

AIR/FUEL VALVE POSITION (% OPEN)	ENERGY INPUT (BTU/HR)	BOILER ENERGY INPUT (% OF FULL CAPACITY)
18% (Stop Level)	155,000	6.2%
30%	400,000	16%
40%	808,000	32%
50%	1,055,000	42%
60%	1,330,000	53%
70%	1,671,000	67%
80%	1,998,000	80%
90%	2,280,000	91%
100%	2,500,000	100%

**3.4.5 BMK 3000 Air/Fuel Valve Position and Energy Input**

**TABLE 3-6a: BMK 3000 Air/Fuel Valve Position – NATURAL GAS**

AIR/FUEL VALVE POSITION (% OPEN)	ENERGY INPUT (BTU/HR.)	BOILER ENERGY INPUT (% OF FULL CAPACITY)
14% (Stop Level)	200,000 (58.6 kW)	6.7%
30%	520,000 (152 kW)	17%
40%	880,000 (258 kW)	29%
50%	1,270,000 (372 kW)	42%
60%	1,680,000 (492 kW)	56%
70%	2,100,000 (615 kW)	70%
80%	2,390,000 (700 kW)	80%
90%	2,650,000 (777 kW)	88%
100%	3,000,000 (879 kW)	100%

**TABLE 3-6b: BMK 3000 Air/Fuel Valve Position – PROPANE GAS**

AIR/FUEL VALVE POSITION (% OPEN)	ENERGY INPUT (BTU/HR)	BOILER ENERGY INPUT (% OF FULL CAPACITY)
18% (Stop Level)	200,000	6.7%
30%	520,000	17%
40%	920,000	31%
50%	1,270,000	42%
60%	1,570,000	52%
70%	1,960,000	65%
80%	2,330,000	78%
90%	2,700,000	90%
100%	3,000,000	100%

## SECTION 4: INITIAL START-UP

### 4.1 INITIAL START-UP REQUIREMENTS

The requirements for the initial start-up of the Benchmark boiler consists of the following:

- Complete the installation (Section 2: *Installation*)
- Set proper controls and limits (Section 2: *Operation of the of the Benchmark PLATINUM 750 – 3000 Operation and Maintenance Guide*)
- Perform combustion calibration (Section 4.5: *Combustion Calibration*, below)
- Test safety devices (Section 5: *Safety Device Testing*)

All applicable installation procedures in Section 2: *Installation* must be fully completed prior to performing the initial start-up of the unit. The initial start-up must be successfully completed prior to putting the unit into service. Starting a unit without the proper piping, venting, or electrical systems can be dangerous and may void the product warranty. The following start-up instructions should be followed precisely in order to operate the unit safely and at a high thermal efficiency, with low flue gas emissions.

Initial unit start-up must be performed **ONLY** by AERCO factory trained start-up and service personnel. After performing the start-up procedures below, it will be necessary to perform the procedures in Section 5: *Safety Device Testing*, below, to complete all initial unit start-up requirements.

An AERCO Gas Fired Startup Sheet, included with each Benchmark unit, must be completed for each unit for warranty validation and a copy must be returned promptly to AERCO via e-mail at: **STARTUP@AERCO.COM**.

#### WARNING!

**DO NOT ATTEMPT TO DRY FIRE THE UNIT.** Starting the unit without a full water level can seriously damage the unit and may result in injury to personnel or property damage. This situation will void any warranty.

### 4.2 TOOLS & INSTRUMENTS FOR COMBUSTION CALIBRATION

To properly perform combustion calibration, the proper instruments and tools must be used and correctly attached to the unit. The following sections outline the necessary tools and instrumentation as well as their installation.

#### 4.2.1 Required Tools & Instrumentation

The following tools and instrumentation are necessary to perform combustion calibration:

- Digital Combustion Analyzer: Oxygen accuracy to  $\pm 0.4\%$ ; Carbon Monoxide (CO) and Nitrogen Oxide (NO<sub>x</sub>) resolution to 1 PPM.
- 0 to 16 inch W.C. (0 to 4.0 kPa) manometer or equivalent gauge and plastic tubing.
- 1/4 inch NPT-to-barbed fittings for use with gas supply manometer or gauge.
- Small and large flat blade screwdrivers.
- Tube of silicone adhesive



### 4.2.2 Installing Gas Supply Manometer

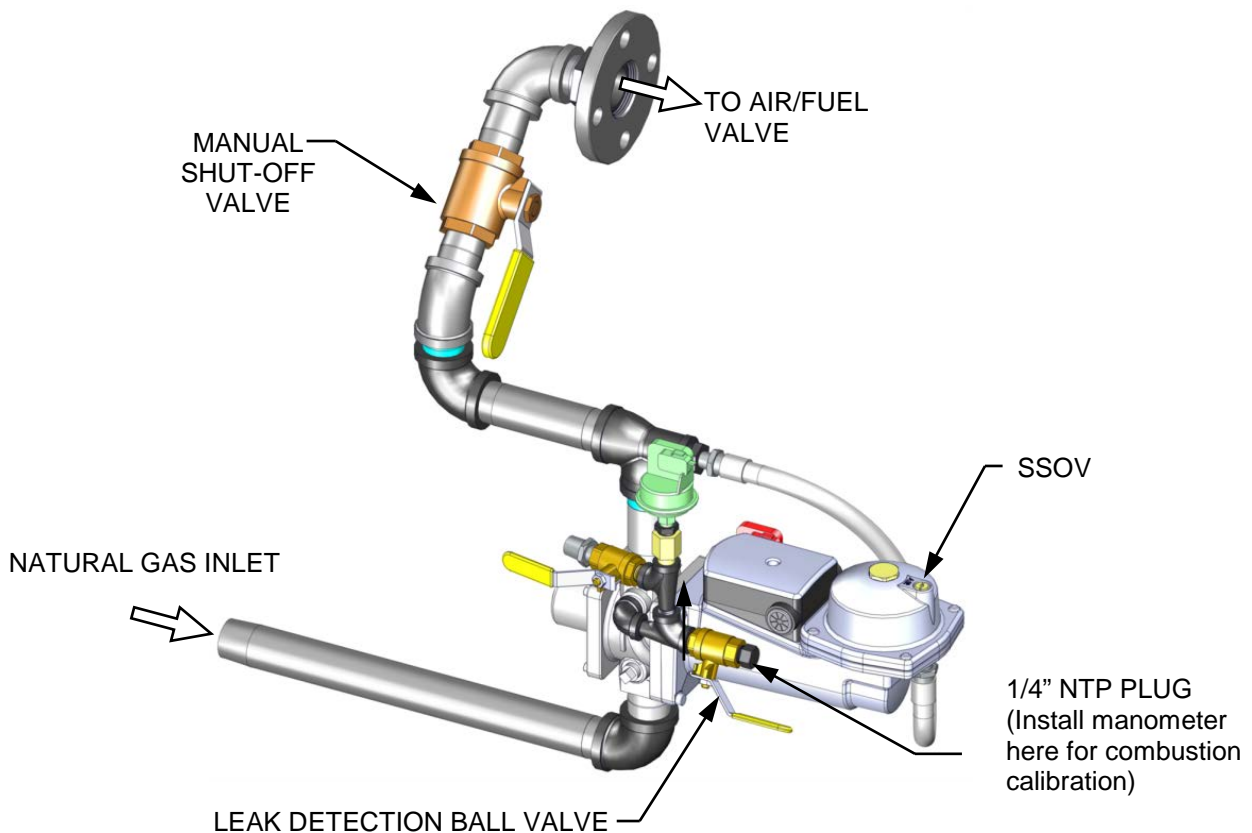
The gas supply manometer (or gauge) is used to monitor the gas pressure on the downstream side of the SSOV during the Combustion Calibration procedures described in Section 4.4.1: *Natural Gas Combustion Calibration* or Section 4.4.2: *Propane Gas Combustion Calibration*

The gas supply manometer is installed at the upstream and/or downstream location shown in Figure 4-1a through 4-1d.

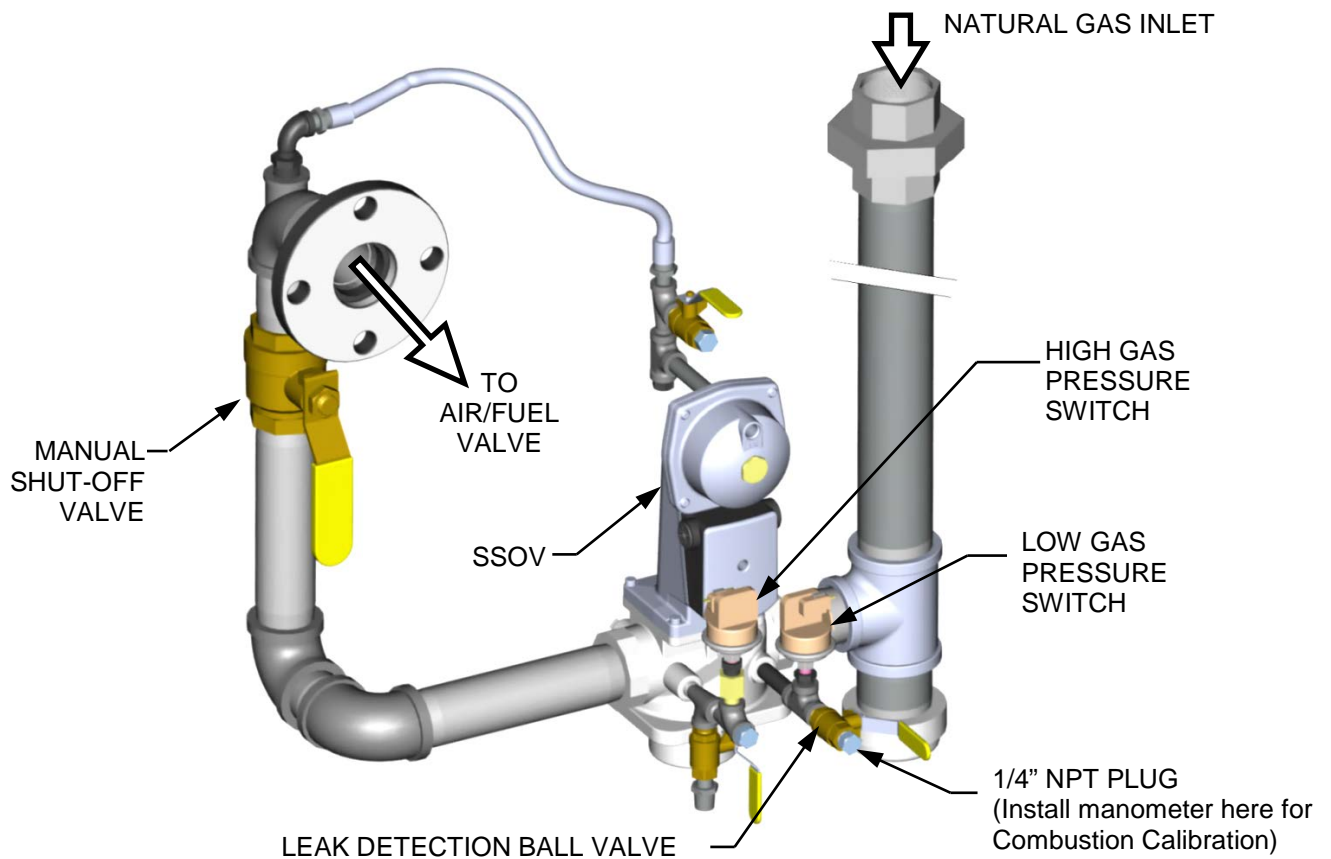
To monitor the gas pressure on the downstream side of the SSOV during Combustion Calibration (in Section 4.4, below), install the 16" W.C. (4.0 kPa) manometer(s) as described in the following steps:

#### Gas Supply Manometer Installation Instructions

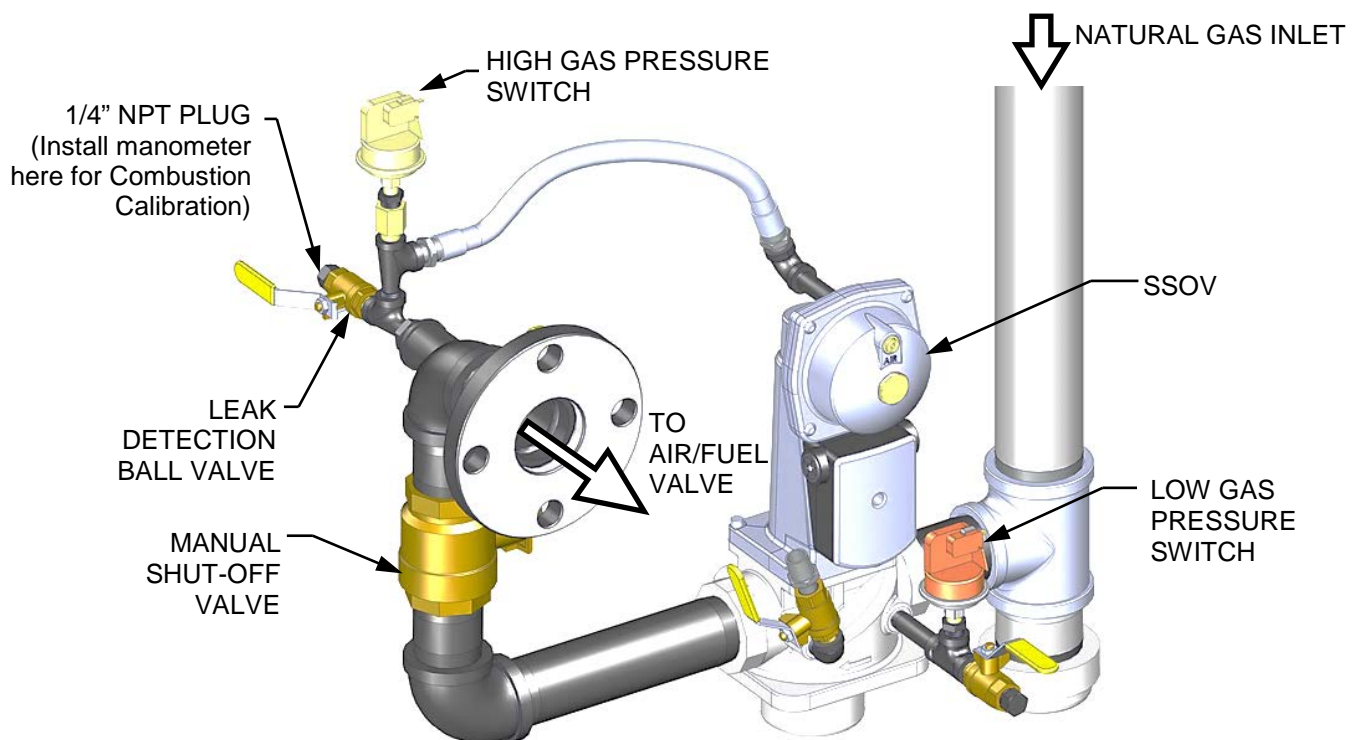
1. Turn off the main gas supply upstream of the unit.
2. Remove the top panel and front panel from the boiler to access the gas train components.
3. Remove the 1/4" NPT plug from the leak detection ball valve on the downstream side of the SSOV as shown in Figure 4-1a – 4-1d.
4. Install a NPT-to-barbed fitting into the tapped plug port.
5. Attach one end of the plastic tubing to the barbed fitting and the other end to the 16" W.C. (4.0 kPa) manometer.



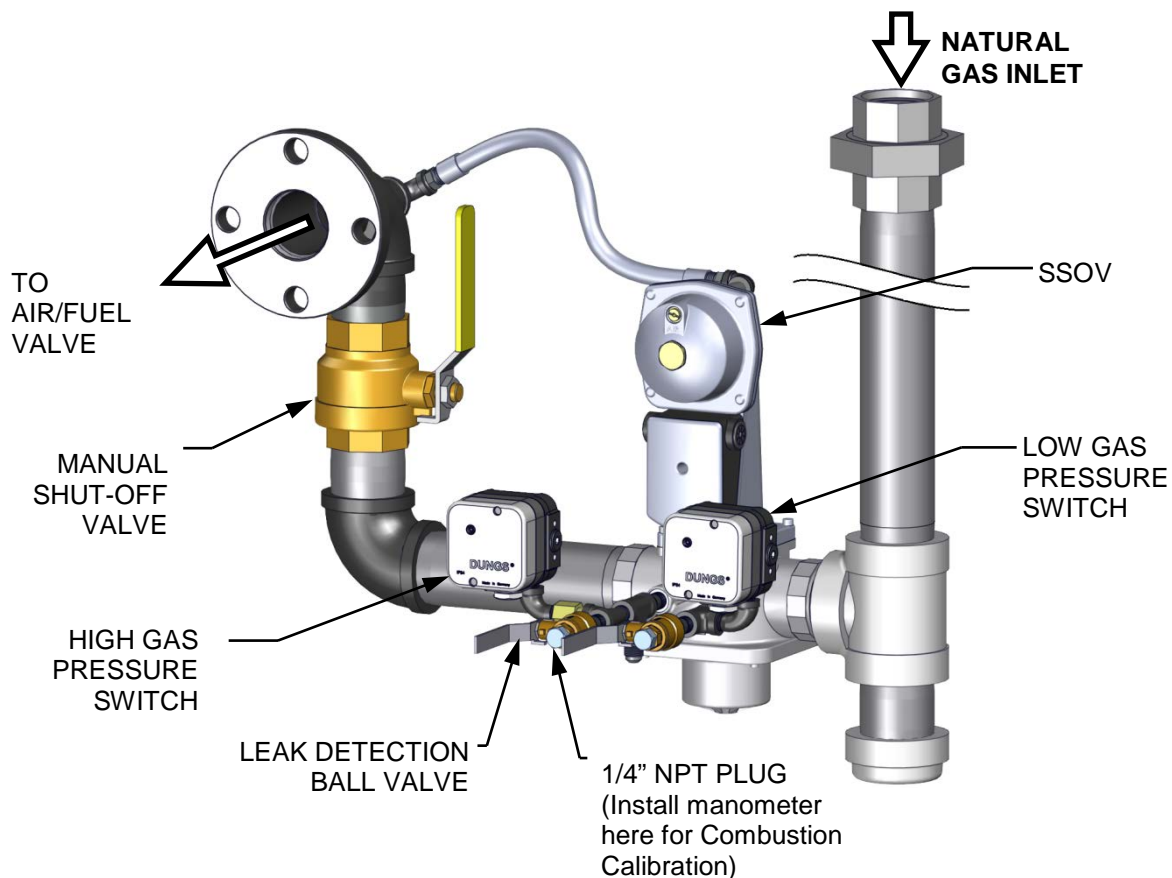
**Figure 4-1a: BMK 750 & 1000 1/4 Inch Gas Plug Location (P/N 22140-1 shown)**



**Figure 4-1b: BMK 1500 & 2000 1/4 Inch Gas Plug Location (P/N 22188 shown)**



**Figure 4-1c: BMK 2500 1/4 Inch Gas Plug Location (P/N 22190 shown)**



**Figure 4-1d: BMK 3000 1/4 Inch Gas Plug Location (P/N 22171 shown)**

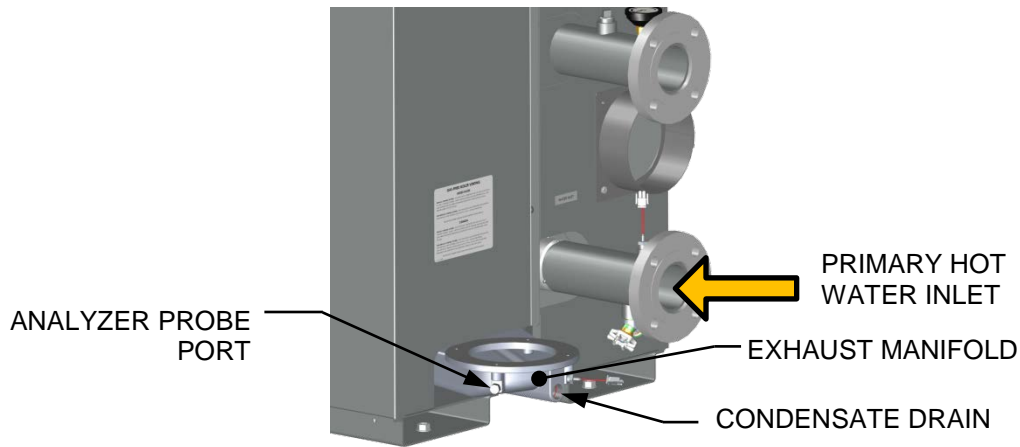
### 4.2.3 Accessing the Analyzer Probe Port

The unit contains a 1/4" NPT port on the side of the exhaust manifold as shown in Figure 4-2a and 4-2b. Prepare the port for the combustion analyzer probe as follows:

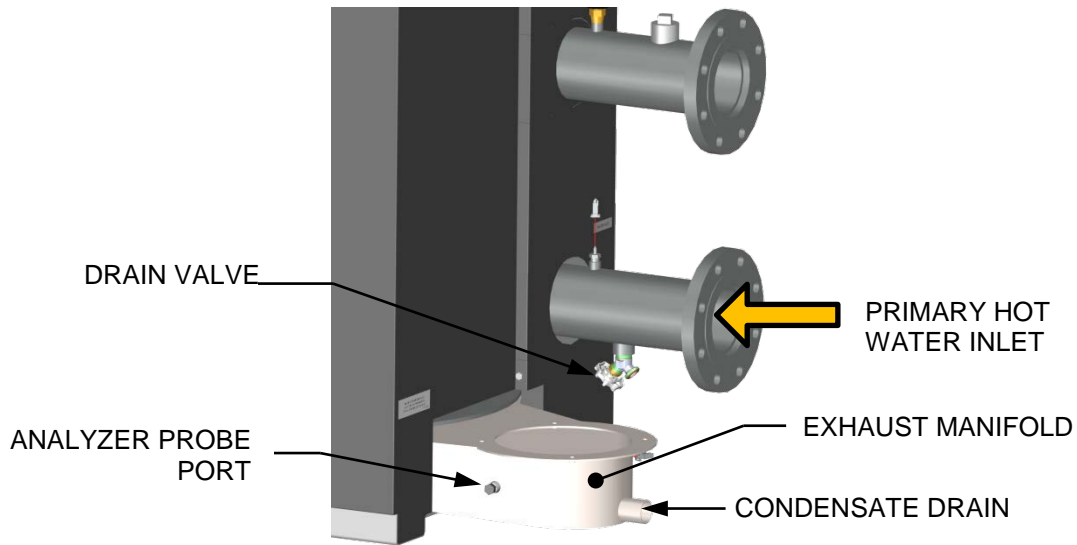
#### Analyzer Probe Port Access Instructions

1. Refer to Figure 4-2a or 4-2b and remove the 1/4" NPT plug from the exhaust manifold.
2. If necessary, adjust the stop on the combustion analyzer probe so it will extend mid-way into the flue gas flow. **DO NOT install the probe at this time.**

### Analyzer Probe Port Access Instructions



**Figure 4-2a: BMK 750 & 1000 Analyzer Probe Port Location**



**Figure 4-2b: BMK 1500 – 3000 Analyzer Probe Port Location**

## 4.3 FUEL TYPES and COMBUSTION CALIBRATION

All BMK Platinum models may be preconfigured at the factory to use either natural gas or propane gas, and BMK models between 1500 and 3000 are available in dual fuel versions, allowing the installer/operator to switch between natural gas and propane gas onsite as needed.

Both fuel types require different combustion calibration values, and so care should be taken to ensure the appropriate instructions are used for the fuel being used. Instructions for natural gas are presented first, then for propane after.

Instructions for switching between fuel types in dual fuel models is presented in sections after all combustion calibration instructions.

### CAUTION!

Ensure the appropriate combustion calibration instructions are used for the fuel being used in the boiler.

## 4.4 COMBUSTION CALIBRATION

The Benchmark boiler is combustion calibrated with either standard combustion or Ultra-Low NO<sub>x</sub> (on the BMK 750/1000 only) at the factory, whichever was ordered, prior to shipping. This gas pressure must be within the ranges shown in Table 4-1 for each model of boiler **at full fire**.

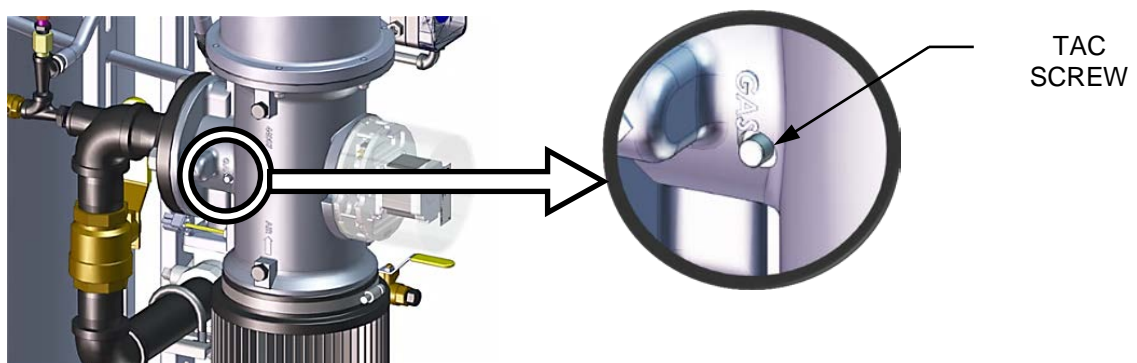
Recalibration as part of initial start-up is necessary due to changes in the local altitude, gas BTU content, gas supply piping and supply regulators. Combustion Calibration Test Data sheets are shipped with each unit. These sheets must be filled out and returned to AERCO for proper Warranty Validation.

**IT IS IMPORTANT TO PERFORM THE COMBUSTION CALIBRATION PROCEDURE BELOW TO PROVIDE OPTIMUM PERFORMANCE AND KEEP READJUSTMENTS TO A MINIMUM.**

- For units running on NATURAL GAS, standard & Ultra-Low NO<sub>x</sub>, complete Section 4.4.1
- For units running on PROPANE gas complete Section 4.4.2



**Figure 4-3: Gas Pressure Adjustment Screw Location**



**Figure 4-4: TAC Screw**



### 4.4.1 NATURAL GAS Combustion Calibration

#### NATURAL GAS Combustion Calibration Instructions

These instructions apply only to units running on **NATURAL GAS**. Instructions for doing combustion calibration on a unit running PROPANE appear in the next section, 4.4.2.

1. Open the water supply and return valves to the unit and ensure that the system pumps are running.
2. Open the **NATURAL GAS** supply valve to the unit.
3. Set the C-More Controller's ON/OFF switch to the **OFF** position
4. Turn external AC power to the unit **ON**. The display will show a description of the unit and then the time and date.
5. Press the **MENU** key on the front panel of the C-More Controller and access the *Setup* menu, enter the password **6817** and then press the **ENTER** key.
6. Set the unit to the MANUAL mode by pressing the **AUTO/MAN** key. A flashing *Manual Valve Position* message will be displayed with the present position in % and the **MANUAL** LED will light.
7. Adjust the air/fuel valve position to **0%** by pressing the ▼ arrow key and then press **ENTER**.
8. Ensure that the leak detection ball valve downstream of the SSOV is open and the manometer is attached and functioning properly.
9. Set the ON/OFF switch to the **ON** position.
10. Press the **MENU** key on the front panel of the C-More Controller until **COMBUSTION CAL MENU** appears on the display.
11. Press the Up ▲ arrow key until **SET Stdby V Out** (*Standby Voltage*) setting appears. Verify that it is set to **2.0 V** (the default). AERCO recommends it be kept at 2.0 volts to prevent flue gas recirculation. Individually vented units in positive pressure boiler rooms may set **SET Stdby V Out** to **0** volts.
12. Press the Down ▼ arrow key until **SET Valve Position** appears, then press **CHANGE**.
13. Use the Up ▲ arrow key to change the valve position to **30%**. The unit should begin its start sequence and fire.
14. Next, verify that the gas pressure downstream of the SSOV is set to the value in Table 4-1 for the model you are calibrating. If gas pressure adjustment is required, remove the brass hex nut on the SSOV actuator to access the gas pressure adjustment screw (Figure 4-3). Make gas pressure adjustments using a flat-tip screwdriver to obtain a gas pressure approximately shown in Table 4-1.

**TABLE 4-1: NATURAL GAS Gas Pressure Range @ 100% Fire Rate**

Model	Single Fuel	Dual Fuel
<b>BMK 750</b>	2.0" ± 0.2" W.C. (0.50 ± 0.05 kPa)	-
<b>BMK 1000</b>	2.4" ± 0.4" W.C. (0.60 ± 0.10 kPa)	-
<b>BMK 1500</b>	3.6" ± 0.1" W.C. (0.90 ± 0.02 kPa)	3.6" ± 0.1" W.C. (0.90 ± 0.02 kPa)
<b>BMK 2000</b>	3.4" ± 0.2" W.C. (0.85 ± 0.05 kPa)	6.3" ± 0.1" W.C. (1.57 ± 0.02 kPa)
<b>BMK 2500</b>	2.0" ± 0.1" W.C. (0.50 ± 0.02 kPa)	5.8" ± 0.1" W.C. (1.44 ± 0.02 kPa)
<b>BMK 3000</b>	2.1" ± 0.2" W.C. (0.52 ± 0.05 kPa)	6.0" ± 0.2" W.C. (1.49 ± 0.05 kPa)

**NATURAL GAS Combustion Calibration Instructions**

15. On Benchmark 3000 units *only*, once the manifold gas pressure is within the range in table 4-1, record this value; it will be used later, in Section 5.2.2: *Low Pressure Gas Test*, and Section 5.3.2: *High Pressure Gas Test*.
16. Press the Down ▼ arrow key until **SET Valve Position** appears on the display, then press **CHANGE**.
17. Press the Up ▲ arrow key until the **SET Valve Position** reads **100%**, then press **ENTER**.
18. With the valve position at 100%, insert the combustion analyzer probe into the exhaust manifold probe opening (see Figure 4-2a or 4-2b in Section 4.2.3) and allow enough time for the combustion analyzer reading to stabilize.
19. Compare the combustion analyzer’s oxygen readings to the O<sub>2</sub> Sensor value displayed in the *Operating* menu on the C-More Controller. The offset value in the *Calibration* menu can be adjusted by ±3% to make the on-board O<sub>2</sub> sensor match the value from the combustion analyzer. If the values differ by more than ±3% and your combustion analyzer is correctly calibrated, the on-board O<sub>2</sub> sensor may be defective and need to be replaced.
20. Compare the measured oxygen level to the oxygen range shown in Table 4-2. Also, ensure that the nitrogen oxide (NO<sub>x</sub>) and carbon monoxide (CO) readings do not exceed the values shown in Table 4-2. If your target NO<sub>x</sub> value is 9 ppm or less, use the values in the Ultra-Low NO<sub>x</sub> columns. If you are not in a “NO<sub>x</sub>-limited” area and/or do not have a NO<sub>x</sub> measurement in your analyzer, set the oxygen (O<sub>2</sub>) at **5.5% ± 0.5%**.

**TABLE 4-2: NATURAL GAS Calibration Readings 100% Valve Position**

Model	Standard NO <sub>x</sub>		Ultra-Low NO <sub>x</sub>		Carbon Monoxide (CO)
	Oxygen (O <sub>2</sub> ) %	Nitrogen Oxide (NO <sub>x</sub> )	Oxygen (O <sub>2</sub> ) %	Nitrogen Oxide (NO <sub>x</sub> )	
750	5.5% ± 0.2%	≤20 ppm	6.0% ± 1.0%	≤9 ppm	<100 ppm
1000	5.5% ± 0.2%	≤20 ppm	6.0% ± 1.0%	≤9 ppm	<100 ppm
1500	5.2% ± 0.2%	≤20 ppm	-	-	<100 ppm
2000	6.0% ± 0.2%	≤20 ppm	-	-	<100 ppm
2500	5.6% ± 0.2%	≤20 ppm	-	-	<100 ppm
3000	5.1% ± 0.2%	≤20 ppm	-	-	<100 ppm
3000 DF	5.3% ± 0.2%	≤20 ppm	-	-	<100 ppm

21. Next, press the Down ▼ arrow key until **CAL Voltage 100%** is displayed.
22. Press the **CHANGE** key and observe that **CAL Voltage 100%** is flashing.
23. The oxygen level at the 100% valve position should match the value in Table 4-2. Also, ensure that the NO<sub>x</sub> and CO readings do not exceed the values in Table 4-2.
24. If the oxygen level is not within the specified range, adjust the level using the ▲ and ▼ arrow keys. This will adjust the output voltage to the blower motor as indicated on the display. Pressing the Up ▲ arrow key increases the oxygen level and pressing the down ▼ arrow key decreases the oxygen level.
25. Once the oxygen level is within the specified range at 100%, press the **ENTER** key to store the selected blower output voltage for the 100% valve position. Record all readings on the Combustion Calibration Sheets provided.



**NATURAL GAS Combustion Calibration Instructions**

26. With the valve position at 100%, if the oxygen level is still not within the required tolerance after adjusting the blower voltage, then the gas pressure on the downstream side of the SSOV must be adjusted using the gas pressure adjustment screw on the SSOV (Figure 4-3). Slowly rotate the gas pressure adjustment in 1/4-turn increments) Clockwise to reduce O<sub>2</sub> level or counterclockwise to increase it. Allow the combustion analyzer to stabilize following each adjustment.
27. Once the oxygen level is within the specified range at 100%, record the O<sub>2</sub>, NO<sub>x</sub> and CO readings on the Combustion Calibration Data Sheets provided with the unit.
28. Press the Up ▲ arrow key until **SET Valve Position** appears and then press **CHANGE**.
29. Use the Down ▼ arrow key to lower the valve position to one of the following:
  - BMK 750 & 1000: **80%**
  - BMK 1500 – 3000: **70%**

**NOTE:**

Remaining combustion calibration steps are performed using the *Combustion Cal* menu in the C-More Controller. The combustion calibration control functions will be used to adjust the oxygen level (%) at valve position percentages described in the steps below. These instructions assume that the **inlet air temperature is between 50°F and 100°F (10°C – 37.8°C)**. If NO<sub>x</sub> readings exceed the target values in Table 4-2, above, increase the O<sub>2</sub> level up to 1% higher than the listed calibration range. Record the increased O<sub>2</sub> value on the Combustion Calibration sheet.

30. Repeat steps 21 through 25 for valve positions shown in Table 4-3a (BMK 750 & 1000) and Table 4-3b (BMK 1500-3000). The O<sub>2</sub>, NO<sub>x</sub> and CO should stay within the ranges shown Table 4-3a and Table 4-3b.

<b>TABLE 4-3a: NATURAL GAS BMK 750/1000 Final Valve Positions</b>					
Valve Position	Standard NO <sub>x</sub>		Ultra-Low NO <sub>x</sub>		Carbon Monoxide (CO)
	Oxygen (O <sub>2</sub> ) %	Nitrogen Oxide (NO <sub>x</sub> )	Oxygen (O <sub>2</sub> ) %	Nitrogen Oxide (NO <sub>x</sub> )	
80%	5.5% ± 0.2%	≤30 ppm	6.0% ± 1.0%	≤09 ppm	<100 ppm
60%	5.5% ± 0.2%	≤30 ppm	6.0% ± 1.0%	≤09 ppm	<100 ppm
45%	5.5% ± 0.2%	≤30 ppm	6.0% ± 1.0%	≤09 ppm	<50 ppm
30%	5.5% ± 0.2%	≤30 ppm	6.0% ± 1.0%	≤09 ppm	<50 ppm
18% *	5.5% ± 0.2%	≤30 ppm	6.0% ± 1.0%	≤09 ppm	<50 ppm

**NATURAL GAS Combustion Calibration Instructions**

**TABLE 4-3b: NATURAL GAS Final Valve Positions**

Single Fuel		Dual Fuel		Nitrogen Oxide (NO <sub>x</sub> )	Carbon Monoxide (CO)
Valve %	Oxygen %	Valve %	Oxygen %		
<b>BMK 1500</b>					
70%	6.0% ± 0.2%	70%	6.0% ± 0.2%	≤20 ppm	<100 ppm
50%	6.3% ± 0.2%	50%	6.3% ± 0.2%	≤20 ppm	<100 ppm
40%	7.0% ± 0.2%	40%	7.0% ± 0.2%	≤20 ppm	<50 ppm
30%	7.0% ± 0.2%	30%	7.0% ± 0.2%	≤20 ppm	<50 ppm
16%	8.0% ± 0.2%	16%	8.0% ± 0.2%	≤20 ppm	<50 ppm
<b>BMK 2000</b>					
70%	5.5% ± 0.2%	70%	6.5% ± 0.2%	≤20 ppm	<100 ppm
50%	5.5% ± 0.2%	50%	6.5% ± 0.2%	≤20 ppm	<100 ppm
40%	6.0% ± 0.2%	40%	6.5% ± 0.2%	≤20 ppm	<50 ppm
30%	6.0% ± 0.2%	30%	6.5% ± 0.2%	≤20 ppm	<50 ppm
18% *	6.5% ± 0.2%	18%	5.5% ± 0.2%	≤20 ppm	<50 ppm
<b>BMK 2500</b>					
70%	5.9% ± 0.2%	70%	5.9% ± 0.2%	≤20 ppm	<100 ppm
50%	6.0% ± 0.2%	45%	6.2% ± 0.2%	≤20 ppm	<100 ppm
40%	6.3% ± 0.2%	30%	6.0% ± 0.2%	≤20 ppm	<50 ppm
30%	6.3% ± 0.2%	20%	5.8% ± 0.2%	≤20 ppm	<50 ppm
16%	6.0% ± 0.2%	16%	6.0% ± 0.2%	≤20 ppm	<50 ppm
<b>BMK 3000</b>					
70%	5.1% ± 0.2%	85%	5.4% ± 0.2%	≤20 ppm	<100 ppm
50%	6.1% ± 0.2%	65%	5.5% ± 0.2%	≤20 ppm	<100 ppm
40%	5.0% ± 0.2%	45%	5.7% ± 0.2%	≤20 ppm	<50 ppm
30%	6.4% ± 0.2%	30%	5.6% ± 0.2%	≤20 ppm	<50 ppm
14%	6.4% ± 0.2%	18%	6.2% ± 0.2%	≤20 ppm	<50 ppm

**NOTES:**

\* Set the Valve Position at 18% but make adjustments to the Combustion Calibration value designated as 16%.

If NO<sub>x</sub> readings exceed the target values in Table 4-3a or 4-3b, increase the O<sub>2</sub> level up to 1% higher than the listed calibration range shown in the table. Record the increased O<sub>2</sub> value on the Combustion Calibration sheet.

31. If the oxygen level at the lowest valve position (14%, 16% or 18%) is too high and the Blower voltage is at the minimum value, you can adjust the TAC screw, which is recessed in the top of the Air/Fuel Valve (see Figure 4-4). Rotate the screw 1/2 turn **clockwise (CW) to add fuel and reduce the O<sub>2</sub>** to the specified level. Recalibration **MUST** be performed again from 60% down to the lowest valve position after making a change to the TAC screw.

**This completes the NATURAL GAS combustion calibration procedure.**

## 4.4.2 PROPANE GAS COMBUSTION CALIBRATION

### PROPANE Combustion Calibration Instructions

These instructions apply only to units running **PROPANE** gas. Instructions for doing combustion calibration on a unit running Natural Gas appear in the previous section, 4.4.1.

1. Open the water supply and return valves to the unit and ensure that the system pumps are running.
2. Open the **PROPANE** supply valve to the unit.
3. Set the C-More Controller's ON/OFF switch to the **OFF** position
4. Turn on external AC power to the unit. The display will show a description of the unit and then the time and date.
5. Press the **MENU** key on the front panel of the C-More Controller and access the *Setup* menu, enter the password **6817** and then press the **ENTER** key.
6. Set the unit to the **MANUAL** mode by pressing the **AUTO/MAN** key. A flashing **Manual Valve Position** message will be displayed with the present position in % and the **MANUAL** LED will light.
7. Adjust the air/fuel valve position to **0%** by pressing the **▼** arrow key and then press **ENTER**.
8. Ensure that the leak detection ball valve downstream of the SSOV is open and the manometer is attached and functioning properly.
9. Set the ON/OFF switch to the **ON** position.
10. Press the **MENU** key on the front panel of the C-More Controller until **COMBUSTION CAL MENU** appears on the display.
11. Press the Up **▲** arrow key until **SET Stdby V Out (Standby Voltage)** setting appears. Verify that it is set to **2.0 V** (the default). AERCO recommends it be kept at 2.0 volts to prevent flue gas recirculation. Individually vented units in positive pressure boiler rooms may set **SET Stdby V Out** to **0** volts.
12. Press the Down **▼** arrow key until **SET Valve Position** appears, then press **CHANGE**.
13. Use the Up **▲** arrow key to change the valve position to **30%**. The unit should begin its start sequence and fire.
14. Next, verify that the gas pressure downstream of the SSOV is set to the value in Table 4-4 for the model you are calibrating. If gas pressure adjustment is required, remove the brass hex nut on the SSOV actuator to access the gas pressure adjustment screw (Figure 4-3). Make gas pressure adjustments using a flat-tip screwdriver to obtain a gas pressure approximately shown in Table 4-4.

**TABLE 4-4: PROPANE Gas Pressure Range @ 100% Fire Rate**

Model	Nominal Gas Pressure
BMK 750P	3.9" W.C. ± 0.2" W.C. (0.97 kPa ± 0.05 kPa)
BMK 1000P	7.6" W.C. ± 0.2" W.C. (1.89 kPa ± 0.05 kPa)
1500DF & 1500P	1.4" W.C. ± 0.1" W.C. (0.35 kPa ± 0.02 kPa)
2000DF & 2000P	2.5" W.C. ± 0.1" W.C. (0.62 kPa ± 0.02 kPa)
2500DF & 2500P	2.0" W.C. ± 0.1" W.C. (0.50 kPa ± 0.02 kPa)
3000DF & 3000P	1.6" W.C. ± 0.1" W.C. (0.40 kPa ± 0.02 kPa)

15. On Benchmark 3000 units *only*, once the manifold gas pressure is within the range in table 4-1, record this value; it will be used later, in Section 5.2.2: *Low Pressure Gas Test*, and Section 5.3.2: *High Pressure Gas Test*.

**PROPANE Combustion Calibration Instructions**

16. Press the Down ▼ arrow key until **SET Valve Position** appears on the display, then press **CHANGE**.
17. Press the Up ▲ arrow key until the **SET Valve Position** reads **100%**, then press **ENTER**.
18. With the valve position at 100%, insert the combustion analyzer probe into the exhaust manifold probe opening (see Figure 4-2a or 4-2b in Section 4.2.3) and allow enough time for the combustion analyzer reading to stabilize.
19. Compare the combustion analyzer's oxygen readings to the O<sub>2</sub> Sensor value displayed in the *Operating* menu on the C-More Controller. The offset value in the *Calibration* menu can be adjusted by ±3% to make the on-board O<sub>2</sub> sensor match the value from the combustion analyzer. If the values differ by more than ±3% and your combustion analyzer is correctly calibrated, the on-board O<sub>2</sub> sensor may be defective and need to be replaced
20. Compare the measured oxygen level to the oxygen range shown in Table 4-5. Also, ensure that the nitrogen oxide (NO<sub>x</sub>) and carbon monoxide (CO) readings do not exceed the values shown in Table 4-5. If you are not in a "NO<sub>x</sub>-limited" area and/or do not have a NO<sub>x</sub> measurement in your analyzer, set the oxygen (O<sub>2</sub>) at **5.5% ± 0.5%**.

<b>TABLE 4-5: PROPANE Calibration Readings at 100% Valve Position</b>			
<b>Model</b>	<b>Oxygen (O<sub>2</sub>) %</b>	<b>Nitrogen Oxide (NO<sub>x</sub>)</b>	<b>Carbon Monoxide (CO)</b>
750 & 1000	5.5% ± 0.2%	≤100 ppm	<150 ppm
1500	5.2% ± 0.2%	≤100 ppm	<150 ppm
2000	6.0% ± 0.2%	≤100 ppm	<150 ppm
2500	5.0% ± 0.2%	≤100 ppm	<150 ppm
3000	5.2% ± 0.2%	≤100 ppm	<150 ppm

21. Next, press the Down ▼ arrow key until **CAL Voltage 100%** is displayed.
22. Press the **CHANGE** key and observe that **CAL Voltage 100%** is flashing.
23. The oxygen level at the 100% valve position should be as shown in Table 4-5. Also, ensure that the NO<sub>x</sub> and CO readings do not exceed the values shown in Table 4-5.
24. If the oxygen level is not within the specified range, adjust the level using the ▲ and ▼ arrow keys. This will adjust the output voltage to the blower motor as indicated on the display. Pressing the Up ▲ arrow key increases the oxygen level and pressing the down ▼ arrow key decreases the oxygen level.
25. Once the oxygen level is within the specified range at 100%, press the **ENTER** key to store the selected blower output voltage for the 100% valve position. Record all readings on the Combustion Calibration Sheets provided.
26. With the unit running at 100% valve position, if the oxygen level is not within the required tolerance after adjusting the blower voltage, then the gas pressure on the downstream side of the SSOV must be adjusted using the gas pressure adjustment screw on the SSOV (Figure 4-3). Slowly rotate the gas pressure adjustment in 1/4-turn increments) Clockwise to reduce O<sub>2</sub> level or counterclockwise to increase it. Allow the combustion analyzer to stabilize following each adjustment.
27. Once the oxygen level is within the specified range at 100%, record the O<sub>2</sub>, NO<sub>x</sub> and CO readings on the Combustion Calibration Data Sheets provided with the unit.
28. Press the Up ▲ arrow key until **SET Valve Position** appears and then press **CHANGE**.

**PROPANE Combustion Calibration Instructions**

29. Use the Down ▼ arrow key to lower the valve position to one of the following:

- BMK 750P & 1000P: **80%**
- BMK 1500/2000/2500 DF & P: **70%**
- BMK 3000 DF & P: **85%**

**NOTE:**

Remaining combustion calibration steps are performed using the *Combustion Cal* menu in the C-More Controller. The combustion calibration control functions will be used to adjust the oxygen level (%) at valve position percentages described in the steps below. These instructions assume that the **inlet air temperature is between 50°F and 100°F (10°C – 37.8°C)**. If NO<sub>x</sub> readings exceed the target values in Table 4-5, above, increase the O<sub>2</sub> level up to 1% higher than the listed calibration range. Record the increased O<sub>2</sub> value on the Combustion Calibration sheet.

30. Repeat steps 21 through 25 for valve positions shown in Table 4-6. The oxygen (O<sub>2</sub>), nitrogen oxide (NO<sub>x</sub>) and carbon monoxide (CO) should stay within the ranges shown Table 4-6.

**TABLE 4-6: Final Valve Positions – PROPANE**

Valve Position	Oxygen (O <sub>2</sub> ) %	Nitrogen oxide (NO <sub>x</sub> )	Carbon Monoxide (CO)
<b>BMK 750/1000</b>			
80%	5.5% ± 0.2%	<100 ppm	<150 ppm
60%	5.5% ± 0.2%	<100 ppm	<150 ppm
45%	5.5% ± 0.2%	<100 ppm	<150 ppm
30%	6.3% ± 0.2%	<100 ppm	<100 ppm
18%	5.5% ± 0.2%	<100 ppm	<100 ppm
<b>BMK 1500</b>			
70%	5.2% ± 0.2%	<100 ppm	<150 ppm
50%	5.3% ± 0.2%	<100 ppm	<150 ppm
40%	6.2% ± 0.2%	<100 ppm	<150 ppm
30%	7.0% ± 0.2%	<100 ppm	<100 ppm
18%	8.5% ± 0.2%	<100 ppm	<100 ppm
<b>BMK 2000</b>			
70%	6.5% ± 0.2%	<100 ppm	<150 ppm
50%	6.5% ± 0.2%	<100 ppm	<150 ppm
40%	6.5% ± 0.2%	<100 ppm	<150 ppm
30%	6.5% ± 0.2%	<100 ppm	<100 ppm
18%	5.5% ± 0.2%	<100 ppm	<100 ppm
<b>BMK 2500</b>			
70%	5.4% ± 0.2%	<100 ppm	<150 ppm
45%	5.6% ± 0.2%	<100 ppm	<150 ppm
30%	6.0% ± 0.2%	<100 ppm	<100 ppm
22%	5.8% ± 0.2%	<100 ppm	<100 ppm
18%	6.0% ± 0.2%	<100 ppm	<100 ppm

**PROPANE Combustion Calibration Instructions**

<b>BMK 3000</b>			
85%	5.2% ± 0.2%	<100 ppm	<150 ppm
65%	5.4% ± 0.2%	<100 ppm	<150 ppm
45%	6.0% ± 0.2%	<100 ppm	<150 ppm
30%	6.4% ± 0.2%	<100 ppm	<100 ppm
18%	6.4% ± 0.2%	<100 ppm	<100 ppm

**\* NOTE:**  
Set the Valve Position at 18% but make adjustments to the Combustion Calibration value designated as 16%.

**NOTE:**  
If NO<sub>x</sub> readings exceed the target values in Table 4-6, increase the O<sub>2</sub> level up to 1% higher than the listed calibration range shown in the table. Record the increased O<sub>2</sub> value on the Combustion Calibration sheet.

- If the oxygen level at the 18% valve position is too high and the Blower voltage is at the minimum value, you can adjust the TAC screw, which is recessed in the top of the Air/Fuel Valve (see Figure 4-4). Rotate the screw 1/2 turn **clockwise (CW) to add fuel and reduce the O<sub>2</sub>** to the specified level. Recalibration **MUST** be performed again from 60% down to the lowest valve position after making a change to the TAC screw.

**This completes the PROPANE gas combustion calibration procedure.**



## 4.5 REASSEMBLY

Once the combustion calibration adjustments are properly set, the unit can be reassembled for service operation.

### Reassembly Instructions

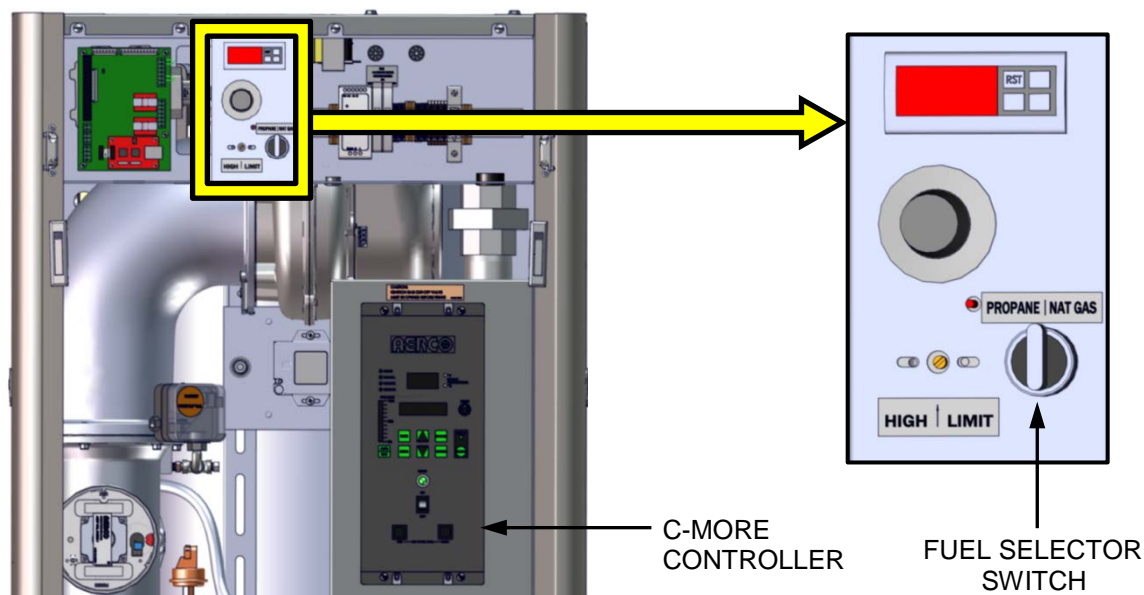
1. Set the ON/OFF switch in the **OFF** position.
2. Disconnect AC power from the unit.
3. Shut off the gas supply to the unit.
4. Remove the manometer and barbed fittings and reinstall the NPT plug using a suitable pipe thread compound.
5. Remove the combustion analyzer probe from the 1/4" vent hole in the exhaust manifold and then replace the 1/4" NPT plug in the vent hole.
6. Replace all previously removed sheet metal enclosures on the unit.

**This concludes reassembly of the unit after combustion calibration.**

## 4.6 DUAL FUEL SWITCHOVER

Dual Fuel models contain a fuel selector switch, located on the Temperature Limit panel. The location of this panel on BMK 1500 – 3000 units is shown in Figure 4-5, below; for the location of this panel on BMK 750 and 1000 units see Figure 4-6a in Section 4.7.

Instructions for switching from one fuel to the other are in Sections 4.6.1 and 4.6.2.



PARTIAL FRONT VIEW WITH FRONT COVER REMOVED

**Figure 4-5: Dual Fuel Switch Location – BMK 1500-3000 Shown**

**4.6.1 Switchover from NATURAL GAS to PROPANE****Switchover from NATURAL GAS to PROPANE Instructions**

1. Set the ON/OFF switch on the C-More Controller to the **OFF** position.
2. Close the external Natural Gas supply valves.
3. Open the external Propane gas supply valves.
4. Refer to Figure 4-5 and locate the Fuel Selector Switch on the unit, behind the front door.
5. Set the Fuel Selector Switch to the **PROPANE** position. A **GAS PRESSURE FAULT** message will be displayed on the C-More Controller.
6. Clear the Gas Pressure Fault by pressing the **CLEAR** key.
7. Set the ON/OFF switch on the C-More Controller to the **ON** position.
8. Press the **MENU** key once. **SETUP MENU** will be displayed.
9. Press the **▲** arrow key once. **PASSWORD** will be displayed.
10. Press the **CHANGE** key. **PASSWORD** will begin to flash.
11. Using the **▲** arrow key, increment the display and stop at **159**.
12. Press the **ENTER** key to store the displayed password.
13. **PASSWORD 1** will be displayed, indicating that the valid Level 1 password has been stored.
14. Next, access the *Configuration* menu by pressing the **MENU** key once.
15. Using the **▲** and **▼** arrow keys, scroll through the *Configuration* menu and stop at **Fuel Type**.
16. Press the **CHANGE** key. **FUEL TYPE** will begin to flash.
17. Press the **▲** arrow key. **PROPANE** will be displayed.
18. Press the **ENTER** key to store the *Propane Fuel type*.
19. Replace the front door panel previously removed from the boiler.

**This completes the switchover from NATURAL GAS to PROPANE.**

**4.6.2 Switchover from PROPANE to NATURAL GAS****Switchover from PROPANE to NATURAL GAS Instructions**

1. Set the ON/OFF switch on the C-More Controller to the **OFF** position.
2. Close the external Propane Gas supply valves.
3. Open the external Natural Gas supply valves.
4. Refer to Figure 4-5 and locate the Fuel Selector Switch on the front of the unit.
5. Set the Fuel Selector Switch to the **NATURAL GAS** position. A **GAS PRESSURE FAULT** message will be displayed on the C-More Controller.
6. Clear the Gas Pressure Fault by pressing the **CLEAR** key.
7. Apply AC power to the boiler.
8. Press the **MENU** key once. **SETUP MENU** will be displayed.
9. Press the **▲** arrow key once. **PASSWORD** will be displayed.
10. Press the **CHANGE** key. **PASSWORD** will begin to flash.
11. Using the **▲** arrow key, increment the display and stop at **159**.
12. Press the **ENTER** key to store the displayed password.
13. **PASSWORD 1** will be displayed, indicating that the valid Level 1 password has been stored.
14. Next, access the *Configuration* menu by pressing the **MENU** key once.
15. Using the **▲** and **▼** arrow keys, scroll through the *Configuration* menu and stop at **FUEL TYPE**.
16. Press the **CHANGE** key. **FUEL TYPE** will begin to flash.
17. Press the **▼** arrow key. **NATURAL GAS** will be displayed.
18. Press the **ENTER** key to store the *Natural Gas Fuel* type.
19. Replace the front door panel previously removed from the boiler.

**This completes the steps necessary to switch from PROPANE Gas to NATURAL GAS.**

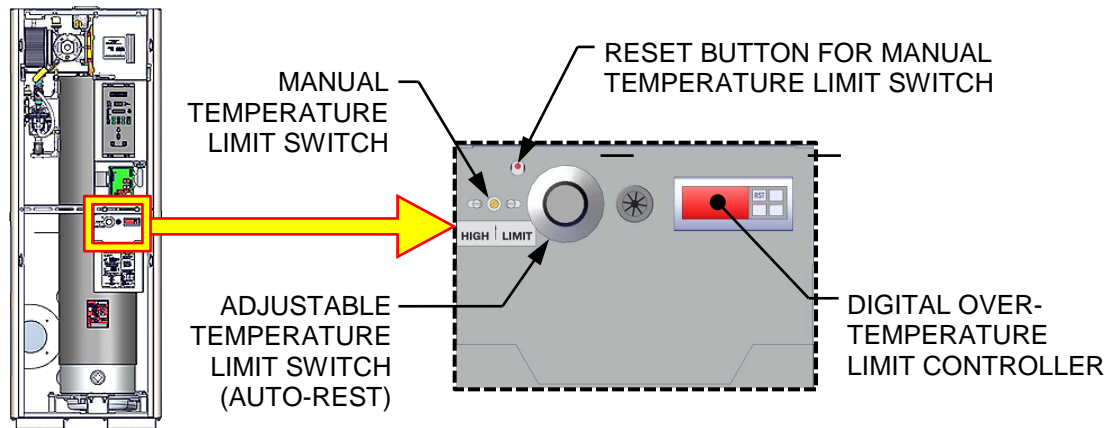
## 4.7 OVER-TEMPERATURE LIMIT SWITCHES

The unit contains three (3) types of over-temperature limit controls. These controls consist of a **Manual Reset** button, a rotary adjustable **Temperature Limit** switch and a digital **Over-Temperature Alarm** button. These controls are mounted on a plate as shown in Figure 4-6a and 4-6b. They can be accessed by opening the front panel door of the unit.

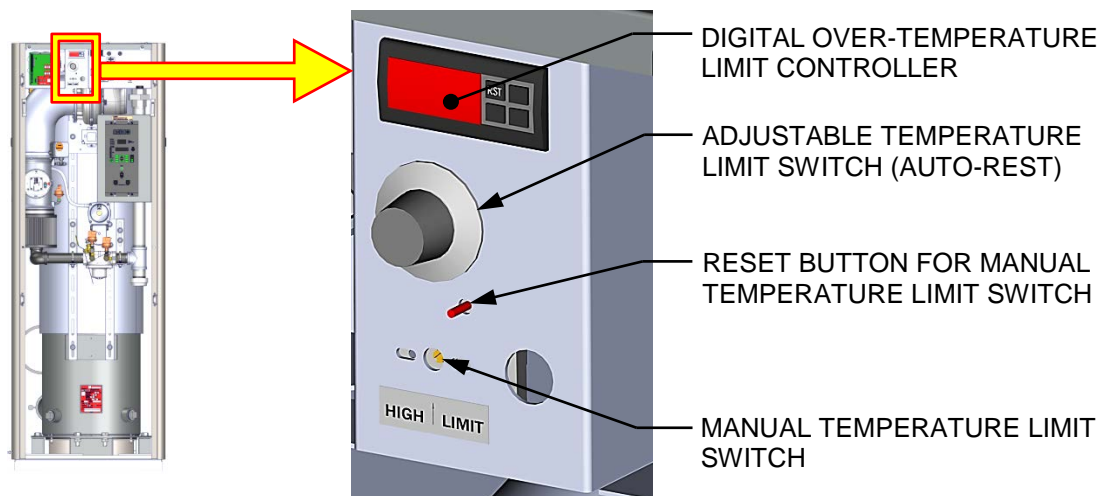
The **Manual Reset** button is not adjustable and is permanently fixed at 210°F (98.9°C). This button will shut down and lock out the boiler if the water temperature exceeds 210°F (98.9°C). Following an over-temperature condition, it must be manually reset by pressing the **Manual Reset** button shown in Figure 4-6a and 4-6b before the boiler can be restarted.

The adjustable **Temperature Limit** switch is manually adjustable from 32°F - 212°F (0°C – 100°C). This switch allows the boiler to restart, once the temperature drops below the selected temperature setting on the dial. Set the dial on this switch to the desired setting.

The digital **Over-Temperature Alarm** switch shown in Figure 4-6a, 4-6b and 4-7 is preset at the factory to 210°F (98.9°C) and should not be changed. If an over-temperature condition is detected, this switch automatically shuts down the boiler and sounds an audible alarm. If desired, the **Over-Temperature Alarm** can be checked or adjusted using the procedure in section 4.7.1.



**Figure 4-6a: BMK 750 & 1000 Over-Temperature Limit Switch Location**



**Figure 4-6b: BMK 1500 – 3000 Over-Temperature Limit Switch Location**

### 4.7.1 Digital Alarm Switch Checks and Adjustments

The **Over-Temperature Alarm** switch settings can be checked or adjusted using the controls and display on the front panel of the switch illustrated and described in Figure 4-7 and Table 4-9.

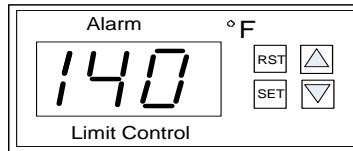


Figure 4-7: Digital Over-Temperature Alarm Switch Front Panel

CONTROL/DISPLAY	MEANING	FUNCTION
LED Display	TEMP status	Displays current water temperature or setpoint.
RST	RESET Button	Resets the unit after an alarm condition.
▲	UP Button	Increases the displayed temperature.
▼	DOWN Button	Decreases the displayed temperature.
SET	SET Button	Used to access and store parameters in the unit.

Perform the following steps to check or adjust the **Over-Temperature Alarm** switch settings:

#### Over-Temp Alarm Switch Check and Adjustment Instructions

1. Set the ON/OFF switch to the **ON** position.
2. Press the **SET** button on the **Over-Temperature Alarm** switch. **SP** will appear in the display.
3. Press the **SET** button again. The current over-temperature limit value stored in memory will be displayed. (Default = 210°F, 98.9°C).
4. If the display does not show the required over-temperature alarm setting, press the ▲ or ▼ arrow button to change the display to the desired temperature setting.
5. Once the desired over-temperature alarm setting (210°F) is displayed, press the **SET** button to store the setting in memory.
6. To calibrate the offset (P1), press and hold the **SET** button on the Over-Temperature Alarm switch for 8 seconds. Access code value **0** should appear in the display. The switch comes from the factory with the code set at 0. AERCO recommends that you do not change this code.
7. Press the **SET** button again to enter the code. The first parameter label, **SP**, will appear in the display.
8. Using the ▲ and ▼ arrow keys, select parameter P1.
9. Press **SET** to view the value stored in memory.
10. If the desired value is not displayed, modify the setting using the ▲ and ▼ arrow keys. The value can be changed from -10° to +10° (-5.5°C to + 5.5°C) offset. Press **SET** to enter the value and exit to the text parameter.
11. To exit the programming mode, press the **SET** and ▼ buttons simultaneously or simply wait one minute and the display will automatically exit the programming mode.
12. Once the programming mode has been exited, the display will show the current outlet water temperature of the boiler.

(This page intentionally blank)



## SECTION 5: SAFETY DEVICE TESTING

### 5.1 TESTING OF SAFETY DEVICES

Periodic safety device testing is required to ensure that the control system and safety devices are operating properly. The boiler control system comprehensively monitors all combustion-related safety devices before, during and after the start sequence. The following tests check to ensure that the system is operating as designed.

Operating controls and safety devices should be tested on a regular basis or following service or replacement. All testing must conform to local codes such as ASME CSD-1.

#### NOTES:

- MANUAL and AUTO modes of operation are required to perform the following tests. For a complete explanation of these modes, see Section 3: *Modes of Operation* in the *Benchmark PLATINUM 750 – 3000 Operation and Maintenance Guide*, OMM-0116 (GF-201).
- It is necessary to remove the front door and side panels from the unit to perform the tests described below.

#### WARNING!

Electrical voltages in this system include 120 VAC (BMK 750 – 20000) or 208 or 460 VAC (BMK 2500/3000) and 24 volts AC. Power must be removed prior to performing wire removal or other test procedures that can result in electrical shock.

## 5.2 LOW GAS PRESSURE TEST

Complete the instructions in Section 5.2.1 for BMK 750 – 2500 units, or in Section 5.2.2 for BMK 3000 units, which have different Low and High Gas Pressure switches.

### 5.2.1 LOW GAS PRESSURE TEST: BMK 750 – 2500

To simulate a low gas pressure fault, refer to Figure 5-1a, 5-1b or 5-1c and perform the following steps:

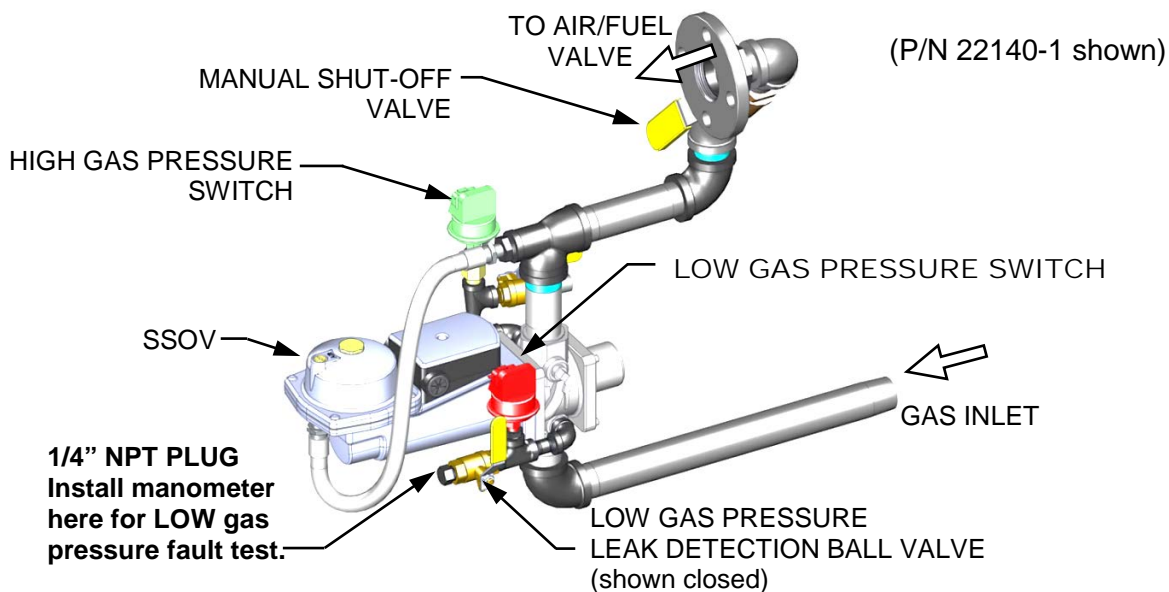
#### LOW Gas Pressure Test Instructions: BMK 750 – 2500

1. Close the leak detection ball valve located at the Low Gas Pressure switch.
2. Remove the 1/4" NPT plug from the ball valve at the Low Gas Pressure switch.
3. Install a **0 - 16" W.C. (0 – 4.0 kPa)** manometer or gauge where the 1/4" plug was removed.
4. Slowly open the ball valve near the Low Gas Pressure switch.
5. Press the **MENU** key on the front panel of the C-More Controller and access the *Setup* menu, enter the password **6817** and then press the **ENTER** key.
6. Place the unit in **MANUAL** mode and adjust the Air/Fuel Valve position (% open) **between 25% and 30%**.
7. While the unit is firing, slowly close the external manual gas shut-off valve (not shown).
8. The unit should shut down and display a **GAS PRESSURE** fault message at approximately the pressure shown in Table 5-1 (the pressure setting of the LOW Gas Pressure switch):

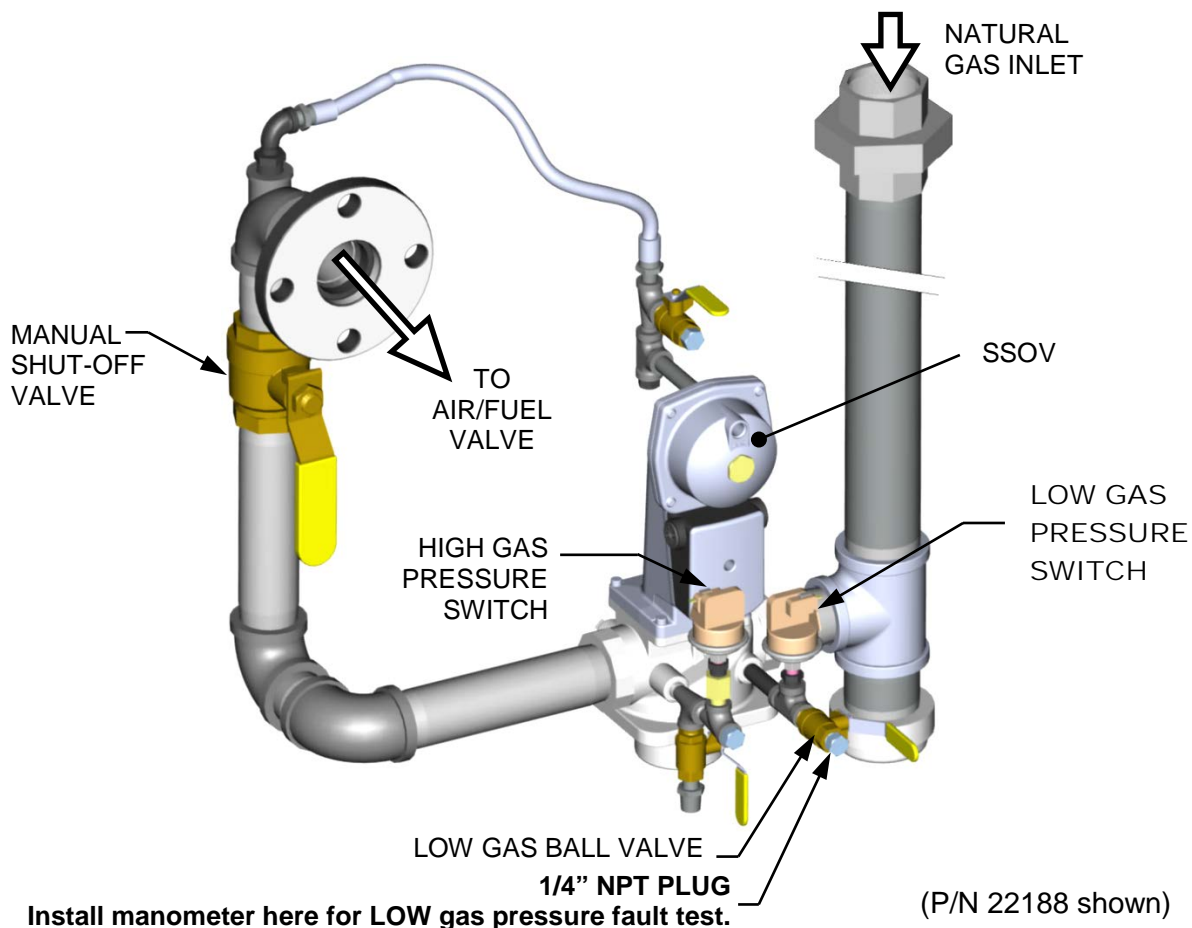
TABLE 5-1: LOW Gas Pressure, ± 0.2" W.C. (± 50 Pa)		
Benchmark Model	Natural Gas	Propane
BMK 750/1000 FM & DBB Single-Fuel	2.6" W.C. (648 Pa)	7.5" W.C. (1,868 Pa)
BMK 1500/2000 FM & DBB Single-Fuel	3.6" W.C. (897 Pa)	–
BMK 1500/2000 Dual-Fuel	4.4" W.C. (1,096 Pa)	2.6" W.C. (648 Pa)
BMK 1500/2000 DBB Dual-Fuel	2.6" W.C. (648 Pa)	2.6" W.C. (648 Pa)
BMK 2500 FM & DBB Single-Fuel	3.6" W.C. (897 Pa)	–
BMK 2500 Dual-Fuel	7.5" W.C. (1,868 Pa)	3.6" W.C. (897 Pa)
BMK 2500 DBB Dual-Fuel	7.5" W.C. (1,868 Pa)	3.6" W.C. (897 Pa)
BMK 3000 FM & DBB Single-Fuel	2.6" W.C. (648 Pa)	–
BMK 3000 Dual-Fuel	7.5" W.C. (1,868 Pa)	2.6" W.C. (648 Pa)
BMK 3000 DBB Dual-Fuel	7.5" W.C. (1,868 Pa)	2.6" W.C. (648 Pa)

9. Fully open the external manual gas shut-off valve (not shown) and press the **CLEAR** button on the C-More Controller.
10. The fault message should clear and the **FAULT** indicator should go off. The unit should restart.
11. Upon test completion, close the ball valve and remove the manometer. Replace the 1/4" NPT plug removed in step 2.

**LOW Gas Pressure Test Instructions: BMK 750 – 2500**

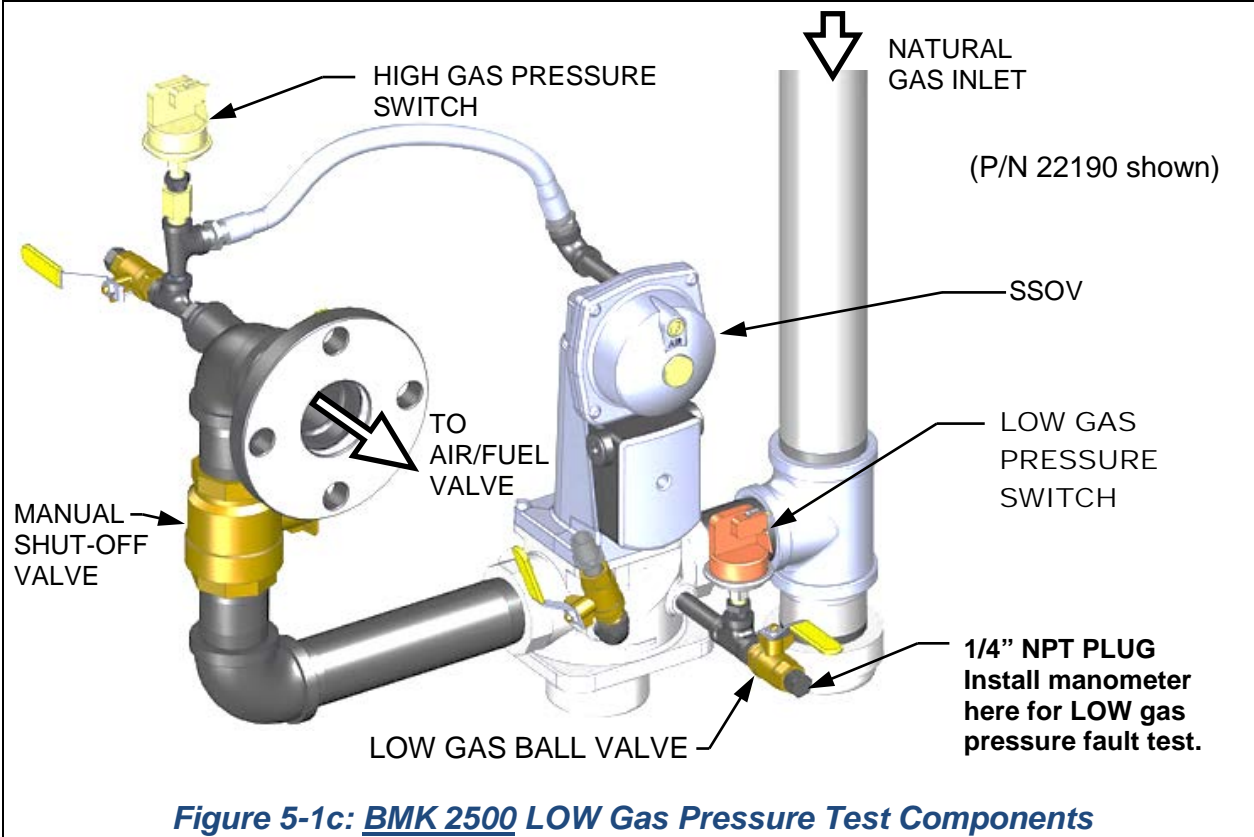


**Figure 5-1a: BMK 750/1000 LOW Gas Pressure Test Components**



**Figure 5-1b: BMK 1500/2000 LOW Gas Pressure Test Components**

**LOW Gas Pressure Test Instructions: BMK 750 – 2500**



**Figure 5-1c: BMK 2500 LOW Gas Pressure Test Components**

**5.2.2 LOW GAS PRESSURE TEST: BMK 3000 Only**

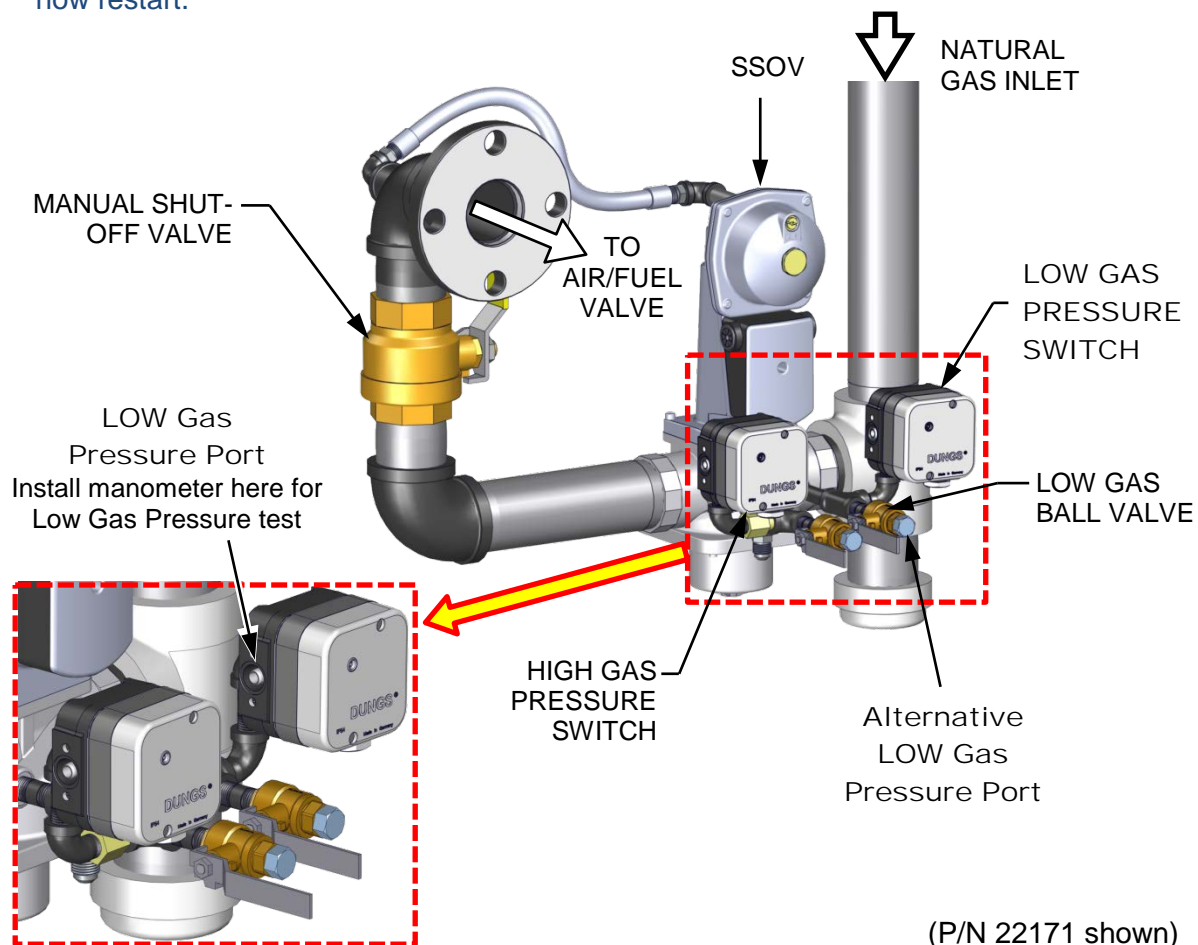
To simulate a low gas pressure fault on BMK 3000 units, refer to Figure 5-2, below, and perform the following steps:

**LOW Gas Pressure Test Instructions: BMK 3000 Only**

1. Close the external gas supply ball valve (not shown) upstream of the unit.
2. Locate the port on the top of the Low Gas Pressure switch (see Figure 5-2, below) and loosen the screw inside a few turns to open it. Do not remove this screw completely. Alternatively, you can remove the 1/4 inch plug shown in Figure 5-2 and install a hose barb fitting in that location.
3. Attach one end of the plastic tubing to the port or barb fitting and the other end to a **16” W.C. (0 – 4.0 kPa)** manometer.
4. Apply the reading of the manifold pressure taken in Step 15 of section 4.4.1 (natural gas units) or Step 15 of section 4.4.2 (propane units) and plug it into the following formula, which calculates the *minimum* allowable gas pressure:
  - FM Natural Gas pressure → \_\_\_ x 0.5 + 0.7 = \_\_\_\_\_ min gas pressure
  - DBB Natural Gas pressure → \_\_\_ x 0.5 + 1.6 = \_\_\_\_\_ min gas pressure
  - Propane Gas pressure → \_\_\_ x 0.5 + 0.6 = \_\_\_\_\_ min gas pressure
5. Remove the cover from the Low Gas Pressure switch and set the dial indicator to **2** (the minimum).
6. Open the external gas supply ball valve (not shown) upstream of the unit.

**LOW Gas Pressure Test Instructions: BMK 3000 Only**

7. Press the **MENU** key on the front panel of the C-More Controller and access the *Setup* menu, enter the password **6817** and then press the **ENTER** key.
8. Place the unit in MANUAL mode and adjust the Air/Fuel Valve position (% open) to **100%**.
9. While the unit is firing, read the CO value on the combustion analyzer and slowly decrease the incoming gas supply pressure until the CO reading is **approximately 300 ppm**.
10. Take a reading of the inlet gas pressure. If the inlet pressure is below the minimum calculated in step 4, above, then increase the pressure to match the calculated minimum.
11. Slowly turn the indicator dial on the Low Gas Pressure switch until the unit shuts down due to a gas pressure fault.
12. Readjust the inlet gas pressure to what it was prior to the test.
13. Press the **CLEAR** button on the C-More Controller to clear the fault.
14. The fault message should clear and the **FAULT** indicator should go off. The unit should now restart.



**Figure 5-2: BMK 3000 LOW and HIGH Gas Pressure Test Components**



## 5.3 HIGH GAS PRESSURE TEST

Complete the instructions in Section 5.3.1 for BMK 750 – 2500 units, or in Section 5.3.2 for BMK 3000 units, which have different High Gas Pressure switches.

### 5.3.1 HIGH GAS PRESSURE TEST: BMK 750 – 2500

To simulate a high gas pressure fault, refer to Figure 5-3a through 5-3c and perform the following steps:

#### HIGH Gas Pressure Test Instructions: BMK 750 – 2500

1. Close the leak detection ball valve located at the **High Gas Pressure** switch.
2. Remove the 1/4" NPT plug from the High Gas pressure leak detection ball valve shown in Figures 5-3a through 5-3c.
3. Install a **0 - 16" W.C. (0 – 4.0 kPa)** manometer or gauge where the 1/4" plug was removed.
4. Slowly open the leak detection ball valve.
5. Press the **MENU** key on the C-More Controller and access the *Setup* menu, enter the password **6817** and then press the **ENTER** key.
6. Start the unit in **MANUAL** mode at a valve position (firing rate) **between 25% and 30%**.
7. With the unit running, monitor the gas pressure on the manometer installed in step 2 and record the gas pressure reading.
8. Slowly increase the gas pressure using the adjustment screw on the SSOV **while counting the number of turns you make**.
9. The **FAULT** indicator should start flashing and the unit should shut down and display a **GAS PRESSURE** fault message at approximately the value shown in Table 5-2 (the pressure setting of the HIGH Gas Pressure switch):

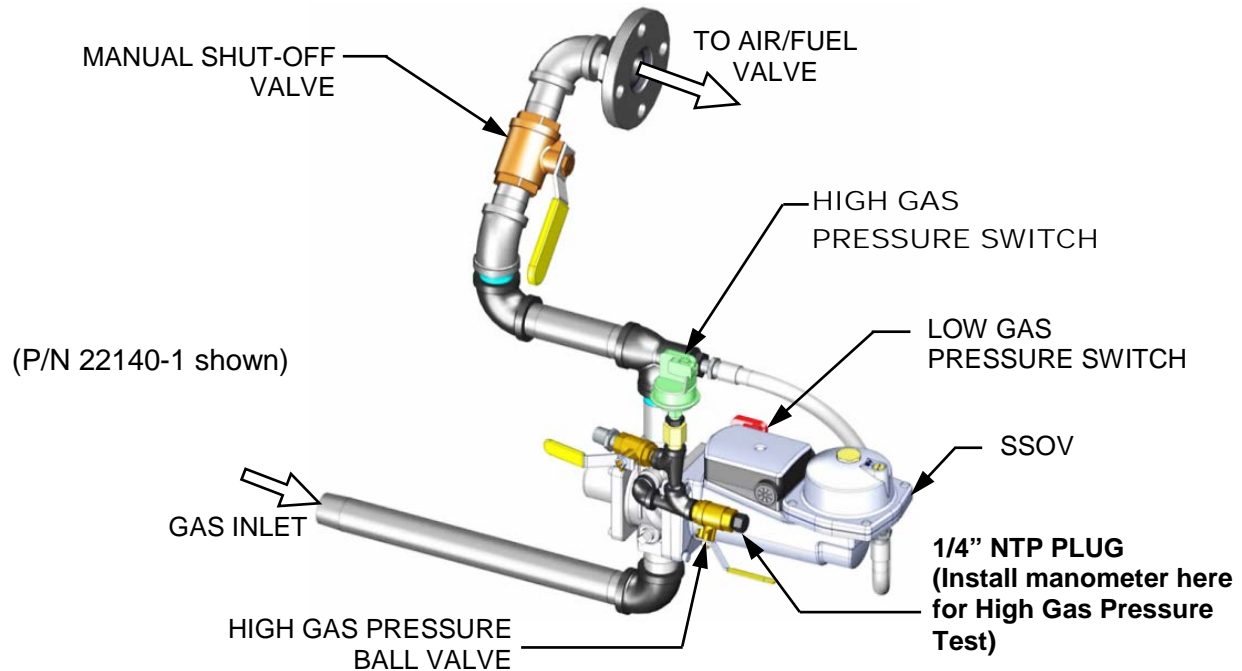
TABLE 5-2: HIGH Gas Pressure, ± 0.2" W.C. (± 50 Pa)		
Benchmark Model	Natural Gas	Propane
BMK 750/1000 FM & DBB Single-Fuel	4.7" W.C. (1.17 KPa)	4.7" W.C. (1.17 KPa)
BMK 1500/2000 Single-Fuel	4.7" W.C. (1.17 KPa)	–
BMK 1500/2000 DBB Single-Fuel	4.7" W.C. (1.17 KPa)	–
BMK 1500/2000 Dual-Fuel	4.7" W.C. (1.17 KPa)	4.7" W.C. (1.17 KPa)
BMK 1500/2000 DBB Dual-Fuel	3.5" W.C. (0.87 kPa)	3.5" W.C. (0.87 kPa)
BMK 2500 FM & DBB Single-Fuel	3.0" W.C. (0.75 kPa)	–
BMK 2500 Dual-Fuel	7.0" W.C. (1,74 kPa)	2.6" W.C. (0.65 kPa)
BMK 2500 DBB Dual-Fuel	7.0" W.C. (1,74 kPa)	2.6" W.C. (0.65 kPa)
BMK 3000 FM & DBB Single-Fuel	3.0" W.C. (0.75 kPa)	–
BMK 3000 Dual-Fuel	6.6" W.C. (1,64 kPa)	2.6" W.C. (0.65 kPa)
BMK 3000 DBB Dual-Fuel	6.6" W.C. (1,64 kPa)	2.6" W.C. (0.65 kPa)

10. Reduce the gas pressure by returning the SSOV adjustment screw back to its position before starting step 7 (the value recorded in step 6). This pressure should be within the range used during combustion calibration, shown in Table 4-1 (Natural Gas) and Table 4-4 (Propane gas).

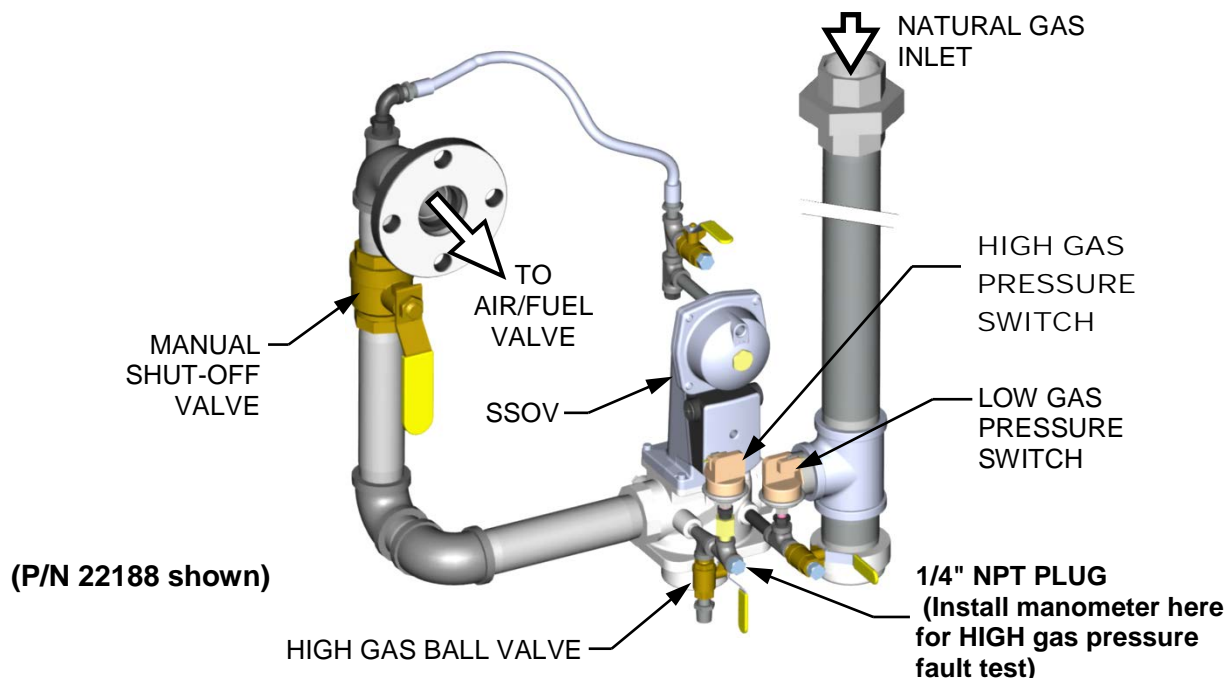


**HIGH Gas Pressure Test Instructions: BMK 750 – 2500**

11. Press the **CLEAR** button on the C-More Controller to clear the fault.
12. The fault message should clear and the **FAULT** indicator should go off. The unit should restart (if in MANUAL mode).
13. Upon test completion, close the ball valve and remove the manometer. Replace the 1/4" NPT plug removed in step 2.

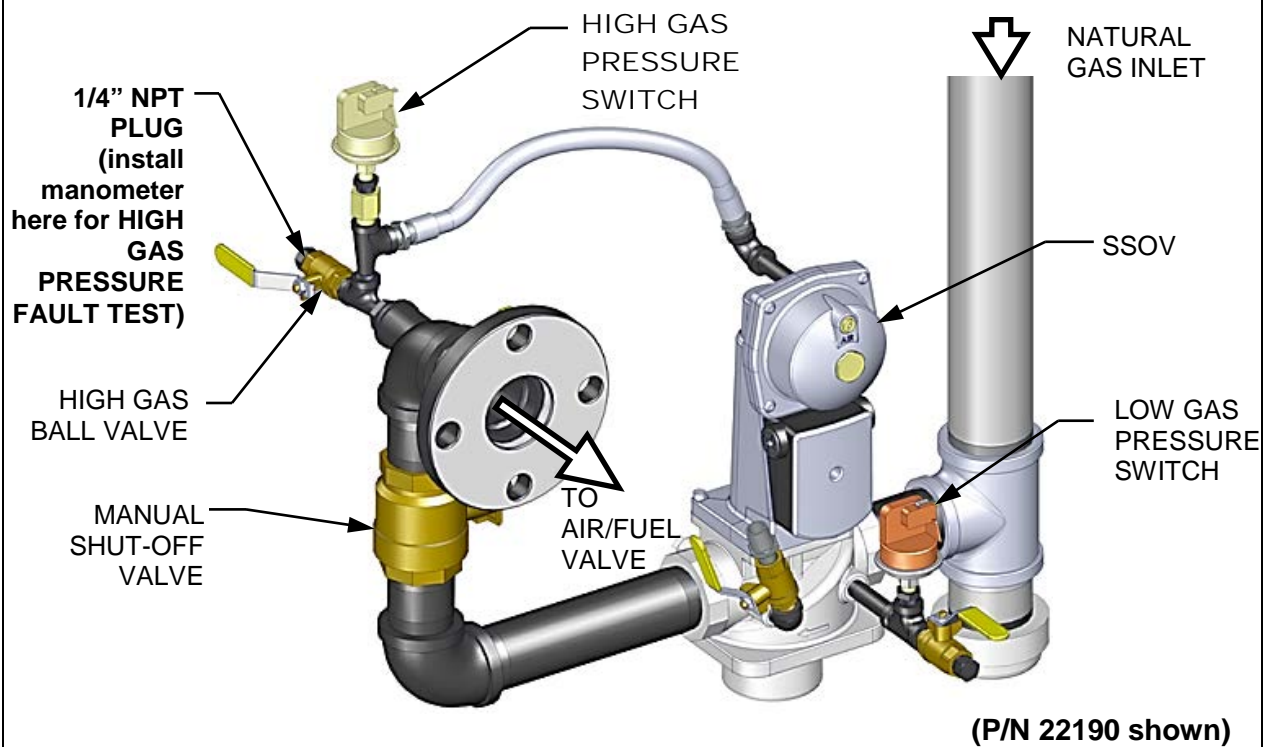


**Figure 5-3a: BMK 750/1000 HIGH Gas Pressure Test Components**



**Figure 5-3b: BMK 1500/2000: HIGH Gas Pressure Fault Test**

**HIGH Gas Pressure Test Instructions: BMK 750 – 2500**



*Figure 5-3c: BMK 2500: HIGH Gas Pressure Fault Test*

**5.3.2 HIGH GAS PRESSURE TEST: BMK 3000 Only**

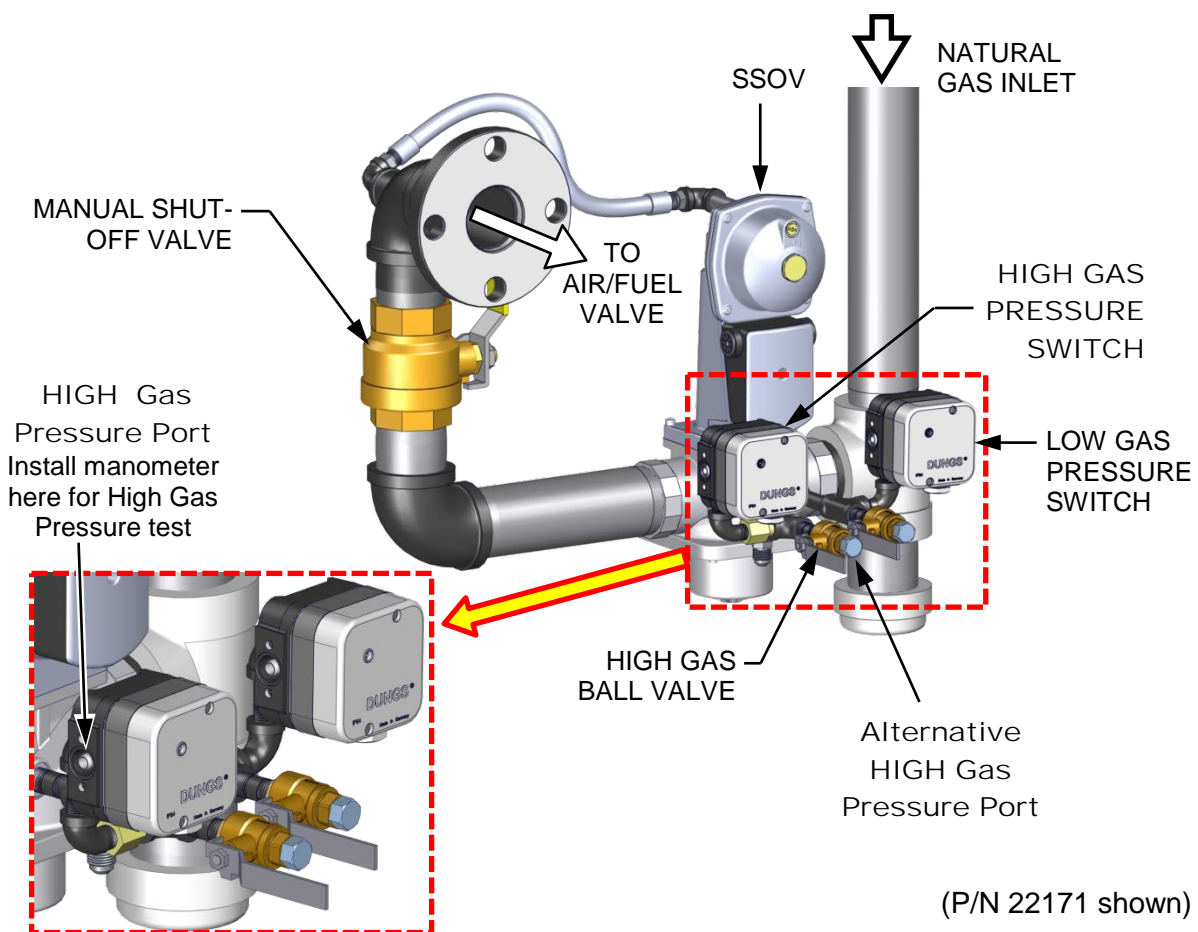
To simulate a high gas pressure fault, refer to Figure 5-4 and perform the following steps:

**HIGH Gas Pressure Test Instructions: BMK 3000 ONLY**

1. Locate the port on the side of the High Gas Pressure switch (see Figure 5-4, below) and loosen the screw in the port a few turns to open it. Do not completely remove the screw. Alternatively, you can remove the 1/4 inch plug shown in Figure 5-4 and install a hose barb fitting in that location.
2. Attach one end of the plastic tubing to the port or barb fitting and the other end to a **0 – 16” W.C. (0 – 4.0 kPa)** manometer.
3. Apply the reading of the manifold pressure taken in Step 15 of section 4.4.1 (natural gas units) or Step 15 of section 4.4.2 (propane units) and plug it into the following formula, which calculates the *maximum* allowable gas pressure:
  - Gas Pressure → \_\_\_\_\_ x 1.5 = \_\_\_\_\_ max gas pressure
4. Remove the cover from the High Gas Pressure switch and **set the dial indicator to 20** (the maximum).
5. Open the external gas supply ball valve upstream of the unit.
6. Press the **MENU** key on the C-More Controller and access the *Setup* menu, enter the password **6817** and then press the **ENTER** key.

**HIGH Gas Pressure Test Instructions: BMK 3000 ONLY**

7. Start the unit in **MANUAL** mode and adjust the Air/Fuel Valve position to bring the unit up to 100%.
8. Slowly increase the manifold gas supply pressure by turning the Gas Pressure Adjustment Screw in the Downstream SSOV (Figure 4-3) while reading the CO level on the combustion analyzer. Adjust the manifold pressure until the CO reading is **approximately 300 ppm**. Note the number of turns you make, as you will turn it back to its original position in step 10, below.
9. Take a reading of the manifold gas pressure. If the manifold pressure is **greater** than the maximum calculated in step 3, then use the Gas Pressure Adjustment Screw to decrease the manifold pressure until it is at the maximum allowed.
10. Press the **RESET** button on the High Gas Pressure switch (see Figure 5-4, below).
11. Slowly turn the indicator dial on the High Gas Pressure switch until the unit shuts down due to a gas pressure fault. This is the setpoint.
12. Readjust the manifold gas supply pressure to what it was before it was increased in step 7.
13. Press the **CLEAR** button on the C-More Controller to clear the fault.
14. Upon test completion, close the ball valve and remove the manometer fitting from the port, and then turn the port screw clockwise till the port is closed.



**Figure 5-4: BMK 3000 HIGH Gas Pressure Test Components**

## 5.4 LOW WATER LEVEL FAULT TEST

To simulate a low water level fault, proceed as follows:

### LOW Water Fault Test Instructions

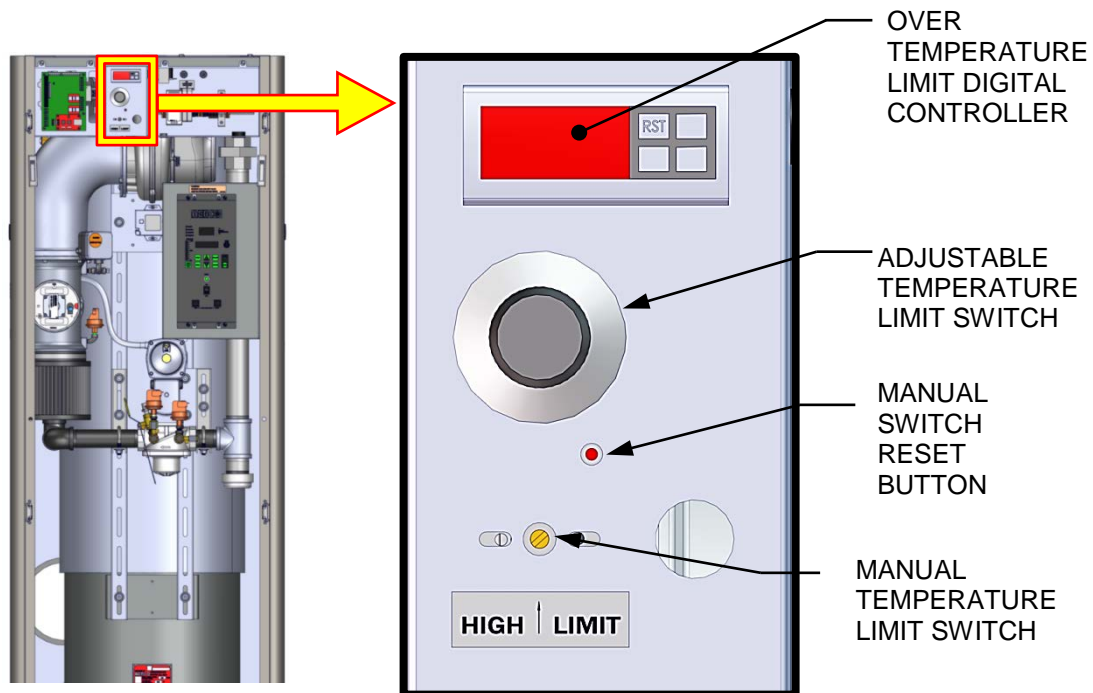
1. Set the ON/OFF switch to the **OFF** position
2. Close the water shut-off valves in the supply and return piping to the unit.
3. Slowly open the drain valve on the rear of the unit. If necessary the unit's relief valve may be opened to aid in draining.
4. Continue draining the unit until a **LOW WATER LEVEL** fault message is displayed and the **FAULT** indicator flashes.
5. Place the unit in the **MANUAL** mode and raise the valve position **above 30%**.
6. Set the ON/OFF switch to the **ON** position. The **READY** light should remain off and the unit should not start. If the unit does start, shut the unit off immediately and refer fault to qualified service personnel.
7. Close the drain and pressure relief valve used in draining the unit.
8. Open the water shut-off valve in the return piping to the unit.
9. Open the water supply shut-off valve to the unit to refill.
10. After the shell is full, press the **LOW WATER LEVEL RESET** button to reset the low water cutoff.
11. Press the **CLEAR** button to reset the **FAULT LED** and clear the displayed error message.
12. Set the ON/OFF switch to the **ON** position. The unit is now ready for operation.

## 5.5 WATER TEMPERATURE FAULT TEST

A high water temperature fault is simulated by adjusting the automatic **Over-Temperature** switch. This switch is accessible from the front of the unit as shown in Figure 5-5a and 5-5b.

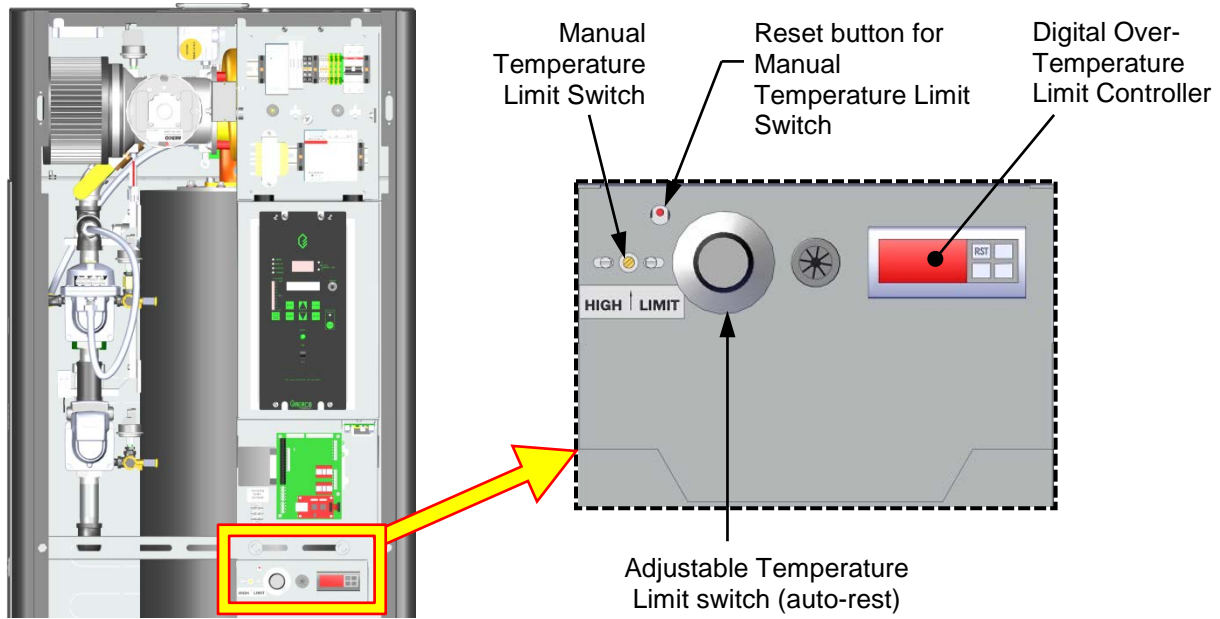
### Water Temperature Fault Test Instructions

1. Start the unit in the normal operating mode. Allow the unit to stabilize at its setpoint.
2. Lower the adjustable Over-Temperature switch setting to match the displayed **OUTLET TEMPERATURE**.
3. Once the adjustable Over-Temperature switch setting is approximately at, or just below, the actual outlet water temperature, the unit should shut down. The FAULT indicator should start flashing and a **HIGH WATER TEMP SWITCH OPEN** fault message should be displayed. It should not be possible to restart the unit.
4. Reset the adjustable Over-Temperature switch to its original setting.
5. The unit should start once the adjustable Temperature Limit switch setting is above the actual outlet water temperature.



**Figure 5-5a: Temperature Limit Switch Location – BMK 1500-3000**

### Water Temperature Fault Test Instructions



**Figure 5-5b: Temperature Limit Switch Location – BMK 750-1000**



## 5.6 INTERLOCK TESTS

The unit is equipped with two interlock circuits called the Remote Interlock and Delayed Interlock. Terminal connections for these circuits are located in the I/O Box (shown in Figure 2-12) and are labeled *REMOTE INTL'K IN* and *DELAYED INTL'K IN*. These circuits can shut down the unit in the event that an interlock is opened. These interlocks are shipped from the factory jumpered (closed). However, each of these interlocks may be utilized in the field as a remote stop and start, an emergency cut-off, or to prove that a device such as a pump, gas booster, or louver is operational.

### 5.6.1 Remote Interlock Test

#### Remote Interlock Test Instructions

1. Remove the cover from the I/O Box and locate the *REMOTE INTL'K IN* terminals.
2. Start the unit in the **MANUAL** mode and set the valve position **between 25% and 30%**.
3. If there is a jumper across the *REMOTE INTL'K IN* terminals, remove one side of the jumper. If the interlock is being controlled by an external device, either open the interlock via the external device or disconnect one of the wires leading to the external device.
4. The unit should shut down and display ***INTERLOCK OPEN***.
5. Once the interlock connection is reconnected, the ***INTERLOCK OPEN*** message should automatically clear and the unit should restart.

### 5.6.2 Delayed Interlock Test

#### Delayed Interlock Test Instructions

1. Remove the cover from the I/O Box and locate the *DELAYED INTL'K IN* terminals.
2. Start the unit in the **MANUAL** mode at a valve position **between 25% and 30%**.
3. If there is a jumper across the *DELAYED INTL'K IN* terminals, remove one side of the jumper. If the interlock is connected to a proving switch of an external device, disconnect one of the wires leading to the proving switch.
4. The unit should shut down and display a ***DELAYED INTERLOCK OPEN*** fault message. The **FAULT LED** should be flashing.
5. Reconnect the wire or jumper removed in step 3 to restore the interlock.
6. Press the **CLEAR** button to reset the fault
7. The unit should start.

## 5.7 FLAME FAULT TEST

Flame faults can occur during ignition or while the unit is already running. To simulate each of these fault conditions, proceed as follows:

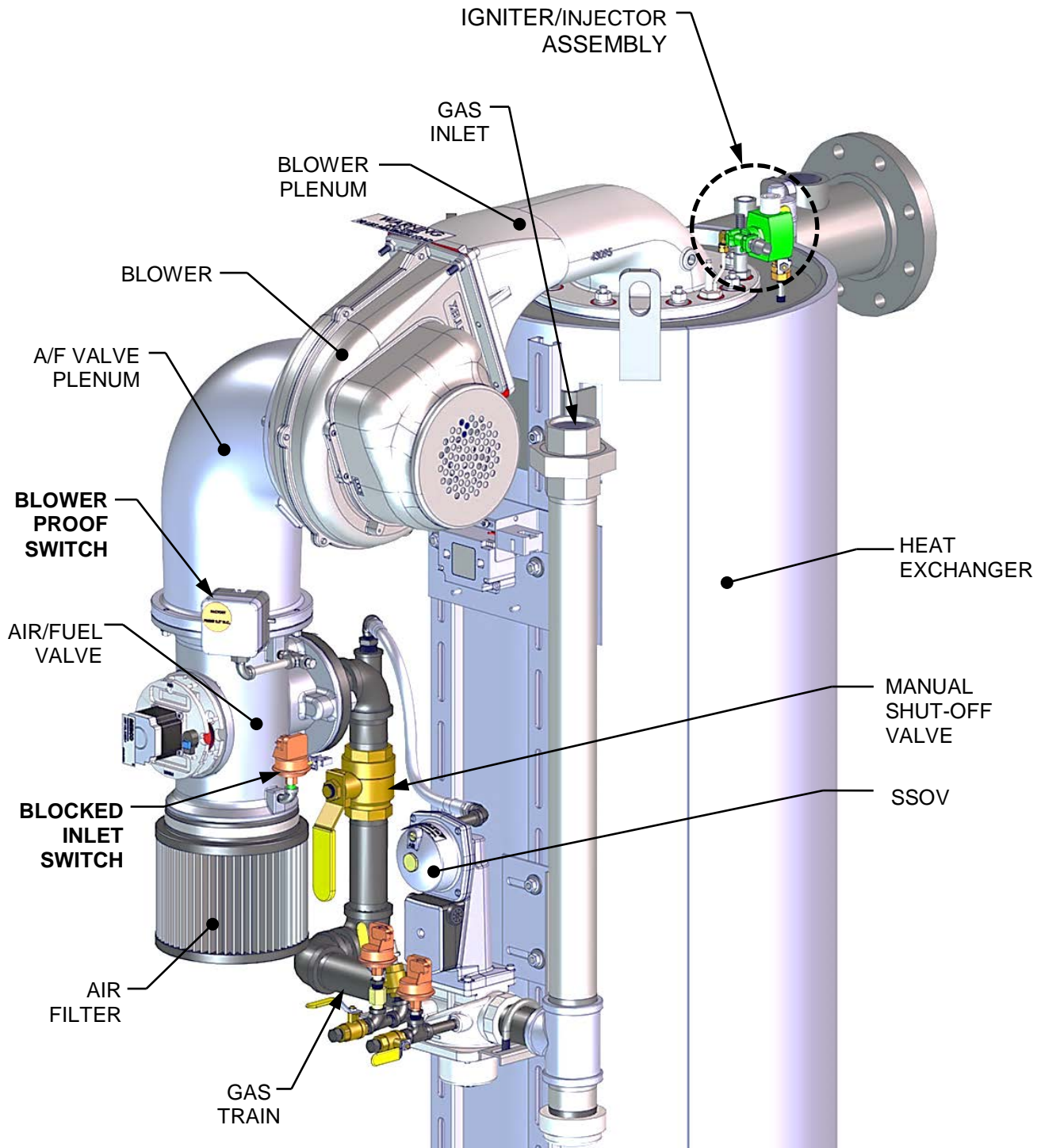
### Flame Fault Test Instructions

1. Set the ON/OFF switch to the **OFF** position.
2. Place the unit in the MANUAL mode and set the valve position **between 25% and 30%**.
3. Close the manual gas shutoff valve located between the Safety Shut-Off Valve (SSOV) and the Air/Fuel Valve, as shown on Figure 5-3a, 5-3b and 5-3c, above.
4. It may be necessary to jump out the High Gas Pressure switch.
5. Set the ON/OFF switch to the **ON** position to start the unit.
6. The unit should purge and light the Pilot flame and then shut down after reaching the main Burner Ignition cycle and display **FLAME LOSS DURING IGN.**
7. Open the valve previously closed in step 3 and press the **CLEAR** button.
8. Restart the unit and allow it to prove flame.
9. Once flame is proven, close the manual gas valve located between the SSOV and the Air/Fuel Valve (see Figure 5-3a, 5-3b or 5-3c, above).
10. The unit should shut down and do one of the following:
  - a) **BMK 2500 & 3000 units:** the unit will Lockout and **FLDR** (*Flame Loss During Run*) will flash in the display.
  - b) **BMK 750 – 2000 units:** the unit will execute an **IGNITION RETRY** cycle by performing the following steps:
    - The unit will execute a shutdown purge cycle for a period of 15 seconds and display **WAIT FAULT PURGE.**
    - The unit will execute a 30 second re-ignition delay and display **WAIT RETRY PAUSE.**
    - The unit will then execute a standard ignition sequence and display **WAIT IGNITION RETRY.**
    - Since the manual gas shutoff valve is still closed, the unit will fail the ignition retry sequence. Therefore it will shut down and display **FLAME LOSS DURING IGN** following the **IGNITION RETRY** cycle.
11. Open the valve closed in step 9.
12. Press the **CLEAR** button. The unit should restart and fire.

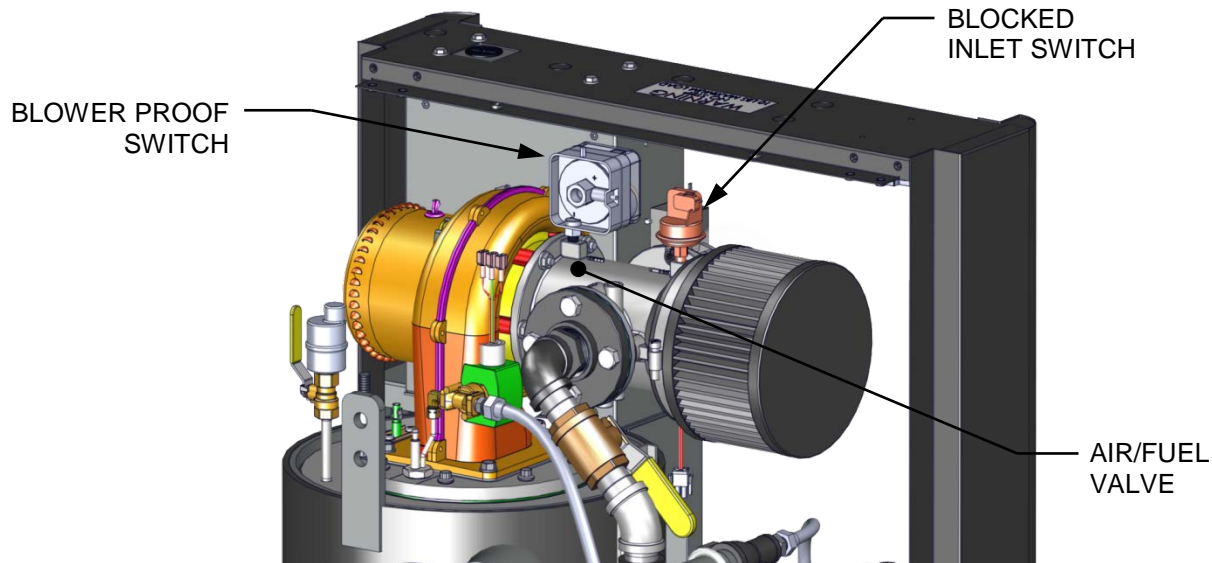
## 5.8 AIR FLOW FAULT TESTS - BLOWER PROOF & BLOCKED INLET SWITCHES

These tests check the operation of the **Blower Proof** switch and **Blocked Inlet** switch shown in Figure 5-6a and 5-6b.

### 5.8.1 Blower Proof Switch Test



**Figure 5-6a: Bare Boiler – Partial View – BMK 1500 – 3000 Shown**



**Figure 5-6b: Bare Boiler – Partial View – BMK 750/13000 Shown**

### Blower Proof Switch Test Instructions

1. Disable the blower output drive voltage as follows:
  - a) Press the **MENU** key until **CONFIGURATION MENU** is displayed.
  - b) Press the **▲** arrow key until the **ANALOG OUTPUT** function is displayed, then press the **CHANGE** key.
  - c) Press the **▼** arrow key until **OFF** is displayed, then press the **ENTER** key.
2. Start the unit in the MANUAL mode at a valve position **between 25% and 30%**.
3. The unit should shut down and lockout, showing **AIRFLOW FAULT DURING PURGE** in the display.
4. The unit should perform one **IGNITION RETRY** cycle and then shut down, since the blower is disabled. The unit will then display **AIRFLOW FAULT DURING PURGE**.
5. Re-enable the blower output drive voltage by performing the following steps:
  - a) Press the **MENU** key until **CONFIGURATION MENU** is displayed.
  - b) Press the **▲** arrow key until the **ANALOG OUTPUT** function is displayed, then press the **CHANGE** key.
  - c) Press the **▲** arrow key until **VALVE POSITION 0-10V** is displayed, then press the **ENTER** key.
  - d) Press the **CLEAR** button to clear the airflow fault.
6. Once the unit has proved flame, turn off the blower again by going to the *Configuration* menu, *Analog Output* menu item and select **OFF**.
7. The Blower Proof switch will open and the blower should stop. The unit should shut down and display **AIRFLOW FAULT DURING RUN**.
8. Go to the *Configuration* menu, *Analog Output* item and select **VALVE POSITION 0-10v**.

## 5.8.2 Blocked Inlet Switch Test

This test will be run in simulated fire mode, with the Blocked Inlet switch isolated from the rest of the control circuitry.

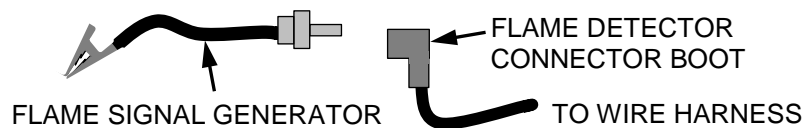
### Blocked Inlet Switch Test Instructions

1. Turn the main ON/OFF switch on the C-More Controller to the **OFF** position.
2. Remove the air filter (see Figure 5-6a or 5-6b, above).

#### WARNING!

The blower suction is very strong and can pull nearby objects into the blower's fan blades. **Do NOT allow anything to be pulled into the blower!** Do not wear anything that could get caught and pull you into the blower.

3. Turn off the gas supply ball valve to the boiler and then complete the following steps:
  - a) Use jumper wires to jump out the Low Gas Pressure switch and the Blower Proof switch.
  - b) Remove the black connector boot from the Flame Detector.
  - c) Connect the Flame Signal Generator to the black connector boot.



**Figure 5-7: Connecting the Flame Signal Generator**

- d) Keep the alligator clip away from bare metal parts until step 4c.
4. Complete the following with the boiler operating in **MANUAL** mode:
  - a) Ramp the boiler up to 100% fire rate and then turn the main ON/OFF switch on the C-More Controller to the **ON** position.
  - b) Push the **BACK** button three (3) times to return to the upper level menu.
  - c) When the C-More Controller gets into the ignition phase, it will show **IGNITION TRIAL**. At that point attach the alligator clip (see Figure 5-7) to any bare metal surface or ground. The C-More Controller display should now show **FLAME PROVEN** and begin to ramp up to 100% fire rate. Note that no gas or flame is present in the boiler at this time.
5. Wait for the boiler to ramp up to at least 90% before continuing.
6. Cover the combustion air inlet opening with a solid, flat object, such as a piece of thick plywood or a thick metal plate.
7. The unit should shut down and display **AIRFLOW FAULT DURING RUN**. This step confirms proper operation of the **Blocked Inlet** switch.
8. Remove the cover from the air inlet opening and reinstall the Combustion Air Duct or air filter.
9. Remove the jumper wires installed in step 3 and replace the black connector boot on the Flame Detector.
10. Press the **CLEAR** button. The unit should restart.

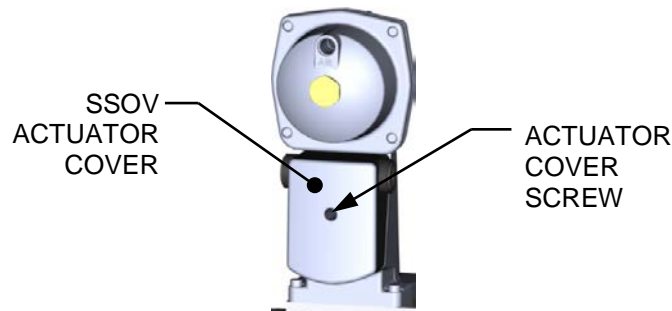


## 5.9 SSOV PROOF OF CLOSURE SWITCH CHECK

The SSOV, shown in Figure 5-8, contains the **Proof of Closure** switch. The **Proof of Closure** switch circuit is checked as follows:

### SSOV Proof Of Closure Switch Check Instructions

1. Set the unit's ON/OFF switch to the **OFF** position.
2. Place the unit in MANUAL mode and set the valve position **between 25% and 30%**.
3. Refer to Figure 5-1a through 5-1c or 5-2 (BMK3000), above, and locate the SSOV.
4. Remove the cover from the SSOV by loosening the screw shown in Figure 5-8. Lift off the cover to access the terminal wiring connections.
5. Disconnect wire #148 from the SSOV to “open” the **Proof Of Closure** switch circuit.
6. The unit should fault and display **SSOV SWITCH OPEN**.
7. Replace wire #148 and press the **CLEAR** button.
8. Set the ON/OFF switch to the **ON** position to start the unit.
9. Remove the wire again when the unit reaches the purge cycle and **PURGING** is displayed.
10. The unit should shut down and display **SSOV FAULT DURING PURGE**.
11. Replace the wire on the SSOV and press the **CLEAR** button. The unit should restart.



**Figure 5-8: SSOV Actuator Cover Location**

## 5.10 PURGE SWITCH OPEN DURING PURGE

The **Purge** switch (and **Ignition** switch) is located on the Air/Fuel Valve. To check the switch, proceed as follows:

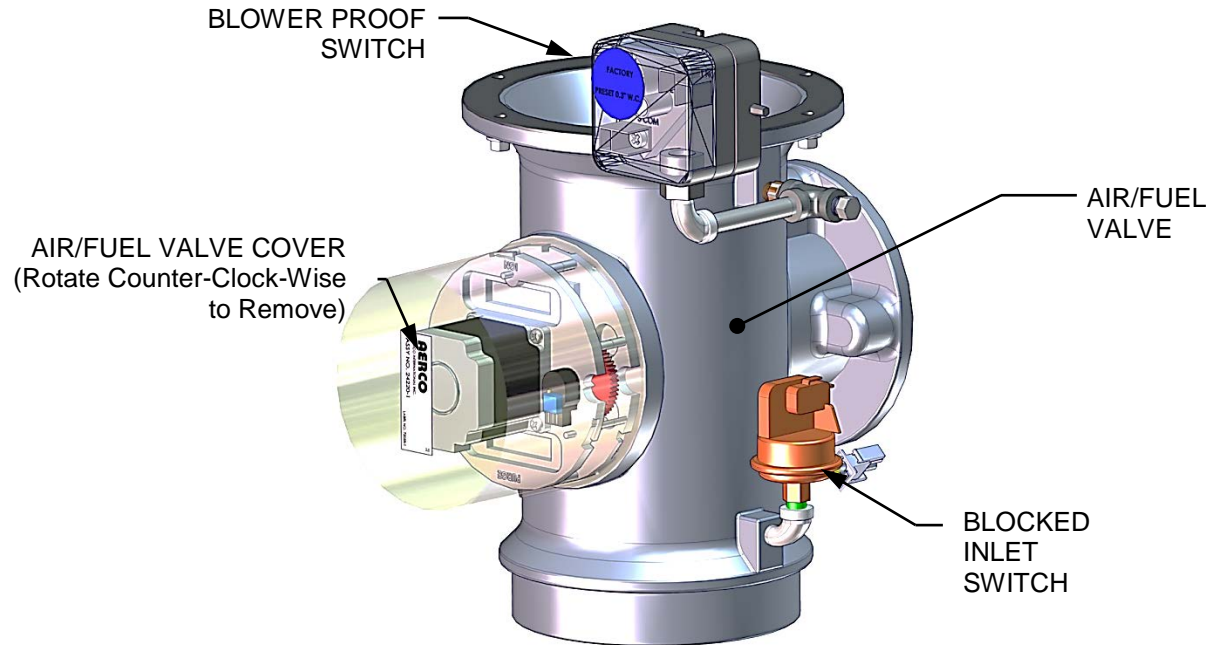
### Purge Switch Open During Purge Check Instructions

1. Set the unit's ON/OFF switch to the **OFF** position.
2. Place the unit in MANUAL mode and set the valve position **between 25% and 30%**.
3. Remove the Air/Fuel Valve cover by rotating the cover counterclockwise to unlock it (see Figure 5-9a and 5-9b).
4. Remove one of the two wires (#171 or #172) from the Purge switch (Figure 5-10a and 5-10b).
5. Initiate a unit start sequence.

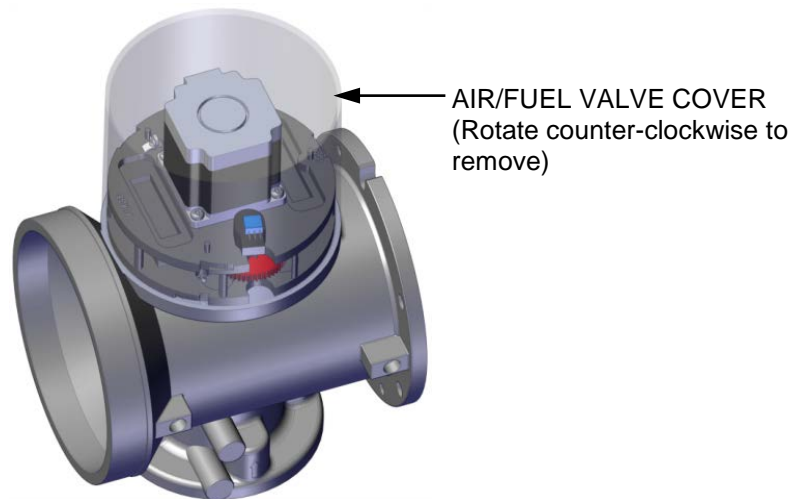


**Purge Switch Open During Purge Check Instructions**

6. The unit should begin its start sequence, then shut down and display **PRG SWITCH OPEN DURING PURGE**.
7. Replace the wire on the **Purge** switch and depress the **CLEAR** button. The unit should restart.

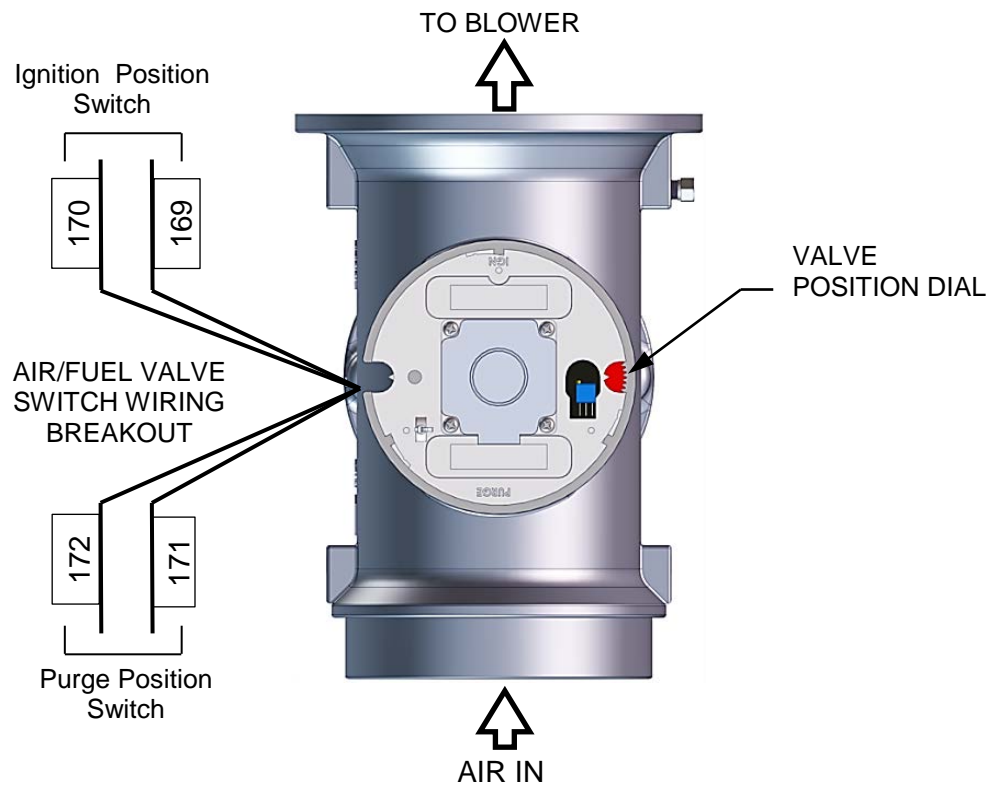


**Figure 5-9a: Air/Fuel Valve Cover Location – BMK 1500 – 3000**

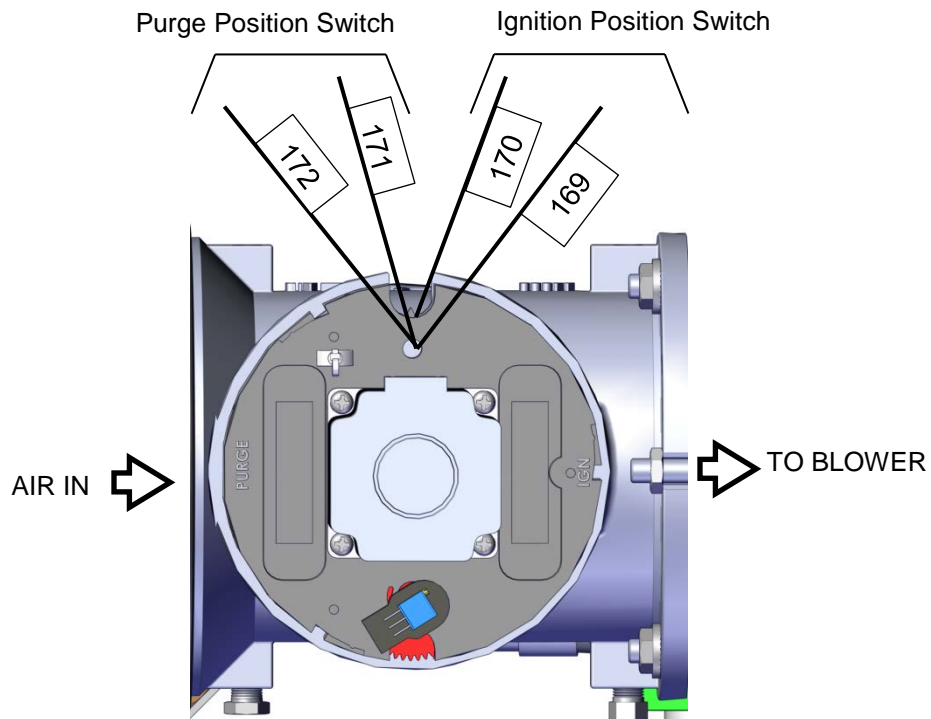


**Figure 5-9b: Air/Fuel Valve Cover Location – BMK 750/1000**

**Purge Switch Open During Purge Check Instructions**



**Figure 5-10a: Air/Fuel Purge and Ignition Locations– BMK 1500 – 3000**



**Figure 5-10b: Air/Fuel Purge and Ignition Locations– BMK 750/1000**

## 5.11 IGNITION SWITCH OPEN DURING IGNITION

The **Ignition** switch (and the **Purge** switch) is located on the Air/Fuel Valve. To check the switch, proceed as follows:

### Ignition Switch Open During Ignition Check Instructions

1. Set the unit's ON/OFF switch to the **OFF** position.
2. Place the unit in MANUAL mode and set the valve position **between 25% and 30%**.
3. Remove the Air/Fuel Valve cover (Figure 5-7a or 5-7b, above) by rotating the cover counterclockwise to unlock and lift up to remove.
4. Remove one of the two wires (#169 or #170) from the Ignition switch (see Figure 5-8a or 5-8b, above).
5. Initiate a unit start sequence.
6. The unit should begin its start sequence and then shut down and display **IGN SWITCH OPEN DURING IGNITION**.
7. Replace the wire on the **Ignition** switch and press the **CLEAR** button. The unit should restart.

## 5.12 SAFETY PRESSURE RELIEF VALVE TEST

Test the safety Pressure Relief Valve in accordance with ASME Boiler and Pressure Vessel Code, Section VI.

(This page intentionally blank)

# SECTION 6: BOILER SEQUENCING TECHNOLOGY

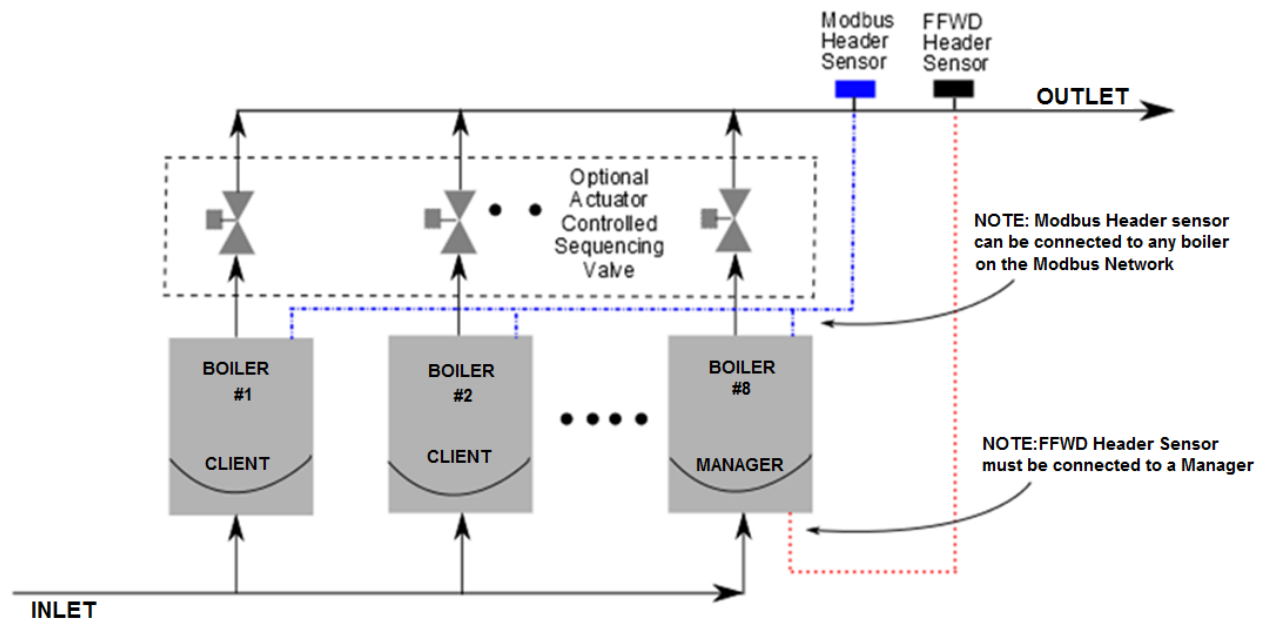
## 6.1 INTRODUCTION

The Boiler Sequencing Technology system (BST) is built into the C-More Controller. BST is an integrated 8 boiler control system. It has its own sophisticated PID control system designed to simultaneously control the light off and modulation of up to 8 boilers while achieving maximum operational efficiency.

BST is designed to ensure that all Boilers in the system operate at maximum efficiency. This is accomplished by lighting off boilers only when all ignited boilers reach or exceed a defined Valve Position (Fire Rate). Operating all boilers below the defined Fire Rate “Next on VP” (for Next Turn on Valve Position) insures that they are firing at their most efficient Fire Rate. One unit the BST network is defined as the “Manager” unit and all other units on the network are defined as “Client” units. The Manager monitors the system Header Temperature, and also monitors all Client unit’s status information, efficiently controlling all units in order to achieve and maintain the required BST Setpoint Temperature.

When there is a demand, the Manager will light off one of the boilers based on the BST Sequencing selection in the BST menu. As system load increases and the valve position of the ignited unit(s) reach the Next On VP (% valve position), the Manager will light off the next available unit. A simplified block diagram of multiple Boilers connected to a BST is shown in Figure 6-1 below.

**NOTE:** Use either FFWD Header Sensor or Modbus Header Sensor



NOTE: Modbus Header sensor can be connected to any boiler on the Modbus Network

NOTE: FFWD Header Sensor must be connected to a Manager

**Figure 6-1: Simplified BST Block Diagram**

**NOTE:**

After the boiler load is satisfied, the isolation valve remains open for a programmed interval (default = 2 minutes) before closing. When the *system load* is satisfied, the **C-More Controller** will open the isolation valves for all of the boilers. The BST controls the valves via a 0-20 mA signal (see section 2.11.8)

### 6.1.1 INSTALLATION NOTES

If you are installing a BST system that also includes a ProtoNode SSD (Client-Client Device), you **must** adhere to the procedure listed below. Failure to complete these steps can result in the failure of the BST system.

- a) Do **NOT** install the ProtoNode device at the outset of the installation. If the ProtoNode Device is already installed, you must physically disconnect it from the Modbus network in I/O board.
- b) Make sure that the Modbus load and bias resistors are properly configured for the system to operate without the ProtoNode installed.
- c) Temporarily set the BST system for CONSTANT SETPOINT mode of operation (see below).
- d) Turn on and completely test the installation to verify that it is operating proper.
- e) Once the installation is working properly as a BST system, install the ProtoNode device.
- f) Make sure that the Modbus load and bias resistors are properly configured for the system to operate with the ProtoNode installed.
- g) Set the BST system for desired mode of operation (SETPOINT mode).
- h) Test the system completely with the ProtoNode installed.

### 6.2 AERCO BST QUICK START CHART

Select the single option that suites your installation and then complete the instructions in the corresponding sub-sections of section 6.3 BST Implementation Instructions.

<b>Constant Setpoint (choose option 1 or 2)</b>	
Option 1 – Direct Wired Header	Complete section 6.3.1
Option 2 – Modbus Header	Complete section 6.3.2
<b>Outdoor Reset (choose option 3 or 4)</b>	
Option 3 – Direct Wired Header AND Direct Wired Outdoor Air	Complete section 6.3.3
Option 4 – Modbus Header AND Modbus Outdoor Air	Complete section 6.3.4
<b>Remote Setpoint (choose option 5 through 8)</b>	
Option 5 – 4-20ma Drive AND Direct Wired Header	Complete section 6.3.5
Option 6 – Modbus Drive AND Direct Wired Header	Complete section 6.3.6
Option 7 – 4-20ma Drive AND Modbus Header	Complete section 6.3.7
Option 8 – Modbus Drive AND Modbus Header	Complete section 6.3.8



## 6.3 BST Implementation Instruction

### 6.3.1 OPTION 1 - CONSTANT SETPOINT WITH DIRECT WIRED HEADER SENSOR

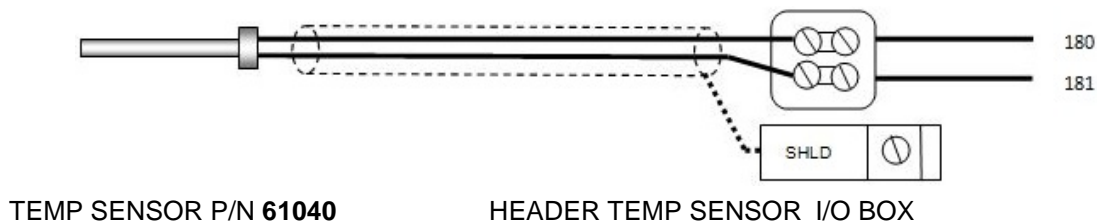
#### OPTION 1 - Constant Setpoint With Direct Wired Header Sensor Instructions

##### Step 1: Direct Wired Header Sensor Wiring

1. On the MANAGER Unit, Connect the Header Temperature Sensor (P/N **61040**) to the Feed Forward (FFWD) terminals on the P-1 Harness Via the terminal block labeled *Header Temp sensor* in the I/O Box.

##### NOTES:

- The header sensor must be installed between 2 and 10 feet (0.61 and 3.1m) downstream of the LAST boiler in the plant's supply water header.
- Shielded pair 18 - 22 AWG cable is recommended for header sensor wiring. There is no polarity to be observed. The ground for the shield is at the "SHLD" terminal in the I/O the Box. The sensor end of the shield must be left free and ungrounded.



##### Step 2: Configure ALL C-More Units

##### On ALL Boilers:

1. Go to the *Configuration* menu and set the BST Menu item to **Enabled**.
2. Go to the Boiler Sequencing Menu and set the BST Mode item to **BST Client** (for now).

##### On MANAGER only:

3. Go to the BST Setpoint item and enter the desired Setpoint.
4. Go to the BST Setup menu item and set to **Enabled**.
5. Go to the BST Setpoint Mode item and select **Constant Setpoint**.
6. Go to the Head Temp Source item and select FFWD Temp.

##### When ALL C-More units have been configured:

7. Go to the Boiler Sequencing Menu of the Manager unit and set the BST Mode item to **BST MANAGER**.

## 6.3.2 OPTION 2 - CONSTANT SETPOINT WITH MODBUS WIRED HEADER SENSOR

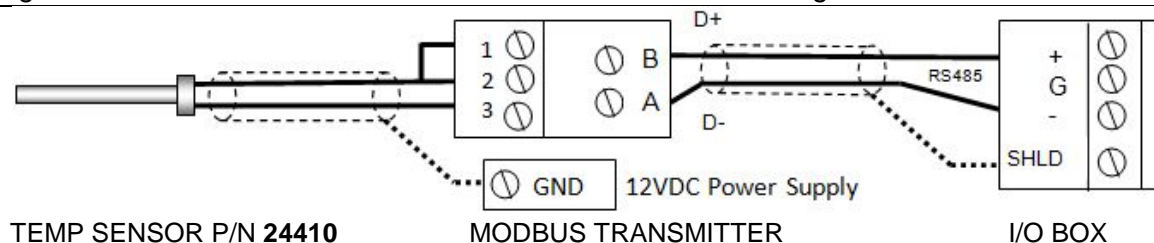
### OPTION 2 - Constant Setpoint With Modbus Wired Header Sensor Instructions

#### Step 1: Modbus Header Sensor Wiring

1. Using Shielded pair 18 - 22 AWG cable, connect the Temperature Transmitter (P/N **65169**) terminal Pin B to the RS485+ terminal on the I/O Box of any of the Boiler units, and Pin A of the Temperature Transmitter to the RS485- terminal on the I/O Box of any of the Boiler units.
2. Using Shielded pair 18 - 22 AWG cable, connect the Modbus Header Temperature Sensor (P/N 24410) to pins 2 and 3 of the Temperature Transmitter.
3. Install a jumper wire between pins 1 and 2 of the Temperature Transmitter.

#### NOTES:

- Polarity must be observed for the RS485 connections.
- The ground for the shield is at the "SHLD" terminal in the I/O the Box.
- The header sensor must be installed between 2 and 10 feet (0.61 and 3.1m) downstream of the LAST boiler in the plant's supply water header.
- There is no polarity to be observed. The ground for the shield is at the power supply ground. The sensor end of the shield must be left free and ungrounded.



#### Step 2: Configure ALL C-More Units

##### On ALL Boilers:

1. Go to the *Configuration* menu and set the BST Menu item to **Enabled**.
2. Go to the Boiler Sequencing Menu and set the BST Mode item to **BST Client** (for now).

##### On MANAGER only:

3. Go to the BST Setpoint item and enter the desired Setpoint.
4. Go to the BST Setup Menu item and set to **Enabled**.
5. Go to the BST Setpoint Mode item and select **Constant Setpoint**.
6. Go to the Head Temp Source item and select **Network**.
7. Go to the Header Temp Addr item and enter the Modbus Address (240).
8. Go to the Header Temp Point item and enter the Modbus Point (14).

##### When ALL C-More units have been configured:

9. Go to the Boiler Sequencing Menu of the Manager unit and set the BST Mode item to **BST MANAGER**.

### 6.3.3 OPTION 3 - OUTDOOR RESET WITH DIRECT WIRED HEADER SENSOR AND DIRECT WIRED OUTDOOR SENSOR

#### OPTION 3 - Outdoor Reset With Direct Wired Header Sensor And Direct Wired Outdoor Sensor Instructions

**NOTE:**

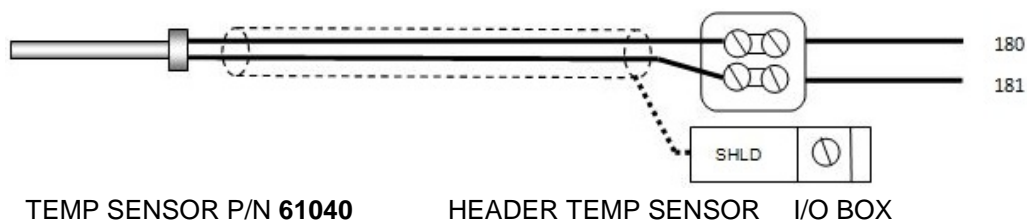
Both Header Sensor AND Outdoor Sensor must be wired. See the *C-More Controller User Manual*, OMM-0032 (GF-112) and *ProtoNode User Manual*, OMM-0080 (GF-129) for more information.

##### Step 1 - Direct Wired Header Sensor Wiring

1. On the MANAGER Unit, connect the Header Temperature Sensor (P/N **61040**) to the Feed Forward (FFWD) terminals on the P-1 Harness Via the terminal block labeled *Header Temp sensor* in the I/O Box.

**NOTE:**

The header sensor must be installed between 2 and 10 (0.61 and 3.1m) feet downstream of the LAST boiler in the plant's supply water header. Shielded pair 18 - 22 AWG cable is recommended for header sensor wiring. There is no polarity to be observed. The ground for the shield is at the "SHLD" terminal in the I/O the Box. The sensor end of the shield must be left free and ungrounded.

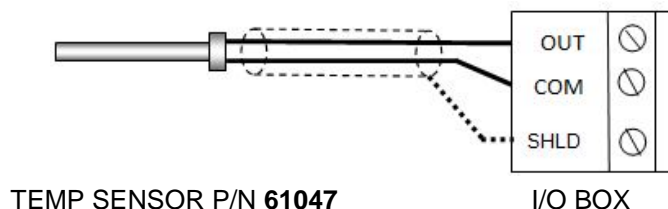


##### Step 2 - Direct Wired Outdoor Sensor

1. On the MANAGER Unit, Connect the Outdoor Temperature Sensor (P/N **61047**) to the "OUT" and "COM" terminals in the I/O Box.

**NOTES:**

- Twisted shielded pair 18 - 22 AWG cable is recommended for header sensor wiring. There is no polarity to be observed. The ground for the shield is at the "SHLD" terminal in the I/O the Box. The sensor end of the shield must be left free and ungrounded.
- When mounting the Outdoor sensor, it must be located on the North side of the building where an average outside air temperature is expected. The sensor must be shielded from direct sunlight as well as impingement by the elements. The outdoor sensor may be wired up to 200 feet (61m) from the boiler.



**OPTION 3 - Outdoor Reset With Direct Wired Header Sensor And Direct Wired Outdoor Sensor Instructions****Step 3 - Configure ALL C-More Units****On ALL Boilers:**

1. Go to the *Configuration* menu and set the BST Menu item to **Enabled**.
2. Go to the Boiler Sequencing Menu and set the BST Mode item to **BST Client** (for now).

**On MANAGER only:**

3. Go to the BST Setpoint item and enter the Failsafe Setpoint.
4. Go to the BST Setup Menu item and set to **Enabled**.
5. Go to the BST Setpoint Mode item and select **Outdoor Reset**.
6. Go to the Head Temp Source item and select **FFWD Temp**.
7. Go to the BST Outdoor Sens item and select **Enabled**.
8. Go to the Outdoor Temp Source item and select **Outdoor Temp**.

**When ALL C-More units have been configured:**

9. Go to the Boiler Sequencing Menu of the Manager unit and set the BST Mode item to **BST MANAGER**.

### 6.3.4 OPTION 4 - OUTDOOR RESET WITH MODBUS HEADER SENSOR AND MODBUS OUTDOOR SENSOR

#### OPTION 4 - Outdoor Reset With Modbus Header Sensor And Modbus Outdoor Sensor Instructions

**NOTE:**

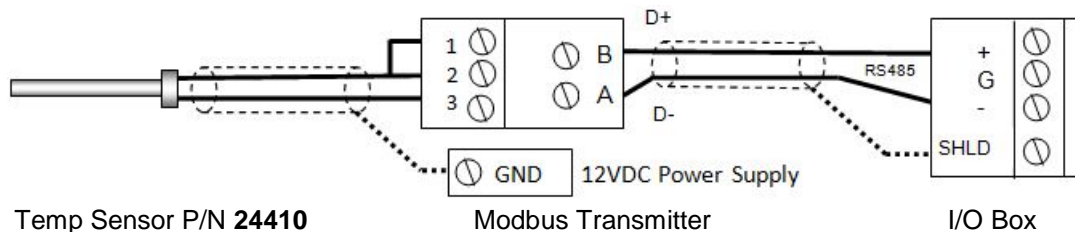
Both Header Sensor AND Outdoor Sensor must be wired. See the *C-More Controller User Manual*, OMM-0032 (GF-112) and *ProtoNode User Manual*, OMM-0080 (GF-129) for more information.

#### Step 1 - Modbus Header Sensor Wiring

1. Using Shielded pair 18 - 22 AWG cable, connect the Temperature Transmitter (P/N **65169**) terminal Pin B to the RS485+ terminal on the I/O Box of any of the Boiler units, and Pin A of the Temperature Transmitter to the RS485- terminal on the I/O Box of any of the Boiler units.
2. Using Shielded pair 18 - 22 AWG cable, connect the Modbus Header Temperature Sensor (P/N 24410) to pins 2 and 3 of the Temperature Transmitter.
3. Install a jumper wire between pins 1 and 2 of the Temperature Transmitter.

**NOTES:**

- Polarity must be observed for the RS485 connections. The ground for the shield is at the "SHLD" terminal in the I/O the Box.
- The header sensor must be installed between 2 and 10 feet (0.61 and 3.1m) downstream of the LAST boiler in the plant's supply water header.
- There is no polarity to be observed. The ground for the shield is at the power supply ground. The sensor end of the shield must be left free and ungrounded.



#### Step 2 - Modbus Outdoor Sensor Wiring

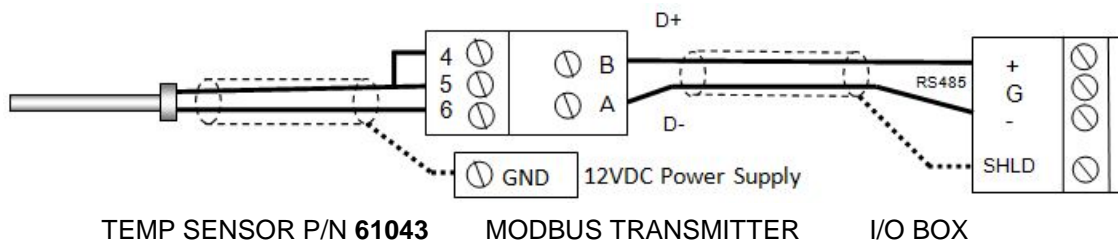
1. If you have not already done so when installing the Modbus Header Sensor, use Shielded pair 18 - 22 AWG cable to connect the Temperature Transmitter terminal Pin B to the RS485+ terminal on the I/O Box of any of the Boiler units, and Pin A of the Temperature Transmitter to the RS485- terminal on the I/O Box of any of the Boiler units.
2. Using Shielded pair 18 - 22 AWG cable, connect the Modbus Header Temperature Sensor (P/N 24410) to pins 2 and 3 of the Temperature Transmitter.
3. Install a jumper wire between pins 1 and 2 of the Temperature Transmitter.

(Continued)

**OPTION 4 - Outdoor Reset With Modbus Header Sensor And Modbus Outdoor Sensor Instructions**

NOTES:

- Polarity must be observed for the RS485 connections. The ground for the shield is at the “SHLD” terminal in the I/O the Box.
- When mounting the Outdoor sensor, it must be located on the North side of the building where an average outside air temperature is expected. The sensor must be shielded from direct sunlight as well as impingement by the elements. The outdoor sensor may be wired up to 200 feet (61m) from the boiler.
- There is no polarity to be observed. The ground for the shield is at the power supply ground. The sensor end of the shield must be left free and ungrounded.



**Step 3 - Configure ALL C-More Units**

**On ALL Boilers:**

1. Go to the *Configuration* menu and set the BST Menu item to **Enabled**.
2. Go to the Boiler Sequencing Menu and set the BST Mode item to **BST Client** (for now).

**On MANAGER only:**

3. Go to the BST Setpoint item and enter the Failsafe Setpoint.
4. Go to the BST Setup Menu item and set to **Enabled**.
5. Go to the BST Setpoint Mode item and select **Outdoor Reset**.
6. Go to the Head Temp Source item and select **Network**.
7. Go to the Header Temp Addr item and enter the Modbus Address (240).
8. Go to the Header Temp Point item and enter the Modbus Point (14).
9. Go to the BST Outdoor Sens item and select **Enabled**.
10. Go to the Outdoor Temp Source item and select **Network**.
11. Go to the Outdoor Temp Addr item and enter the Modbus Address (240).
12. Go to the Outdoor Temp Point item and enter the Modbus Point (15).

**When ALL C-More units have been configured:**

13. Go to the Boiler Sequencing Menu of the Manager unit and set the BST Mode item to **BST MANAGER**.



### 6.3.5 OPTION 5 - REMOTE SETPOINT WITH DIRECT WIRED HEADER SENSOR AND 4-20MA SETPOINT DRIVE

#### OPTION 5 - Remote Setpoint With Direct Wired Header Sensor And 4-20ma Setpoint Drive Instructions

**NOTE:**

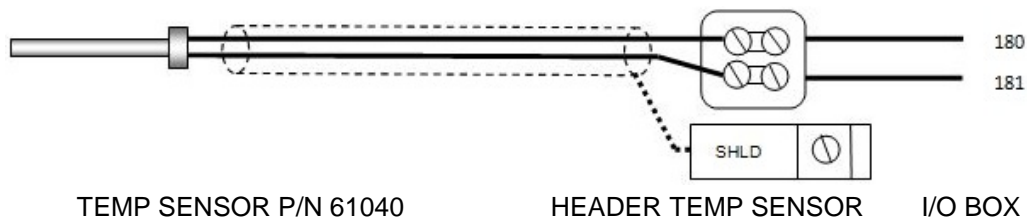
Both Header Sensor AND 4-20ma Direct Drive must be wired. See the *C-More Controller User Manual*, OMM-0032 (GF-112) and *ProtoNode User Manual*, OMM-0080 (GF-129) for more information.

#### Step 1: Direct Wired Header Sensor Wiring

1. On the MANAGER Unit, Connect the Header Temperature Sensor (P/N **61040**) to the Feed Forward (FFWD) terminals on the P-1 Harness Via the terminal block labeled *Header Temp sensor* in the I/O Box.

**NOTES:**

- The header sensor must be installed between 2 and 10 feet (0.61 and 3.1m) downstream of the LAST boiler in the plant's supply water header.
- Shielded pair 18 - 22 AWG cable is recommended for header sensor wiring.
- There is no polarity to be observed.
- The ground for the shield is at the "SHLD" terminal in the I/O the Box.
- The sensor end of the shield must be left free and ungrounded.

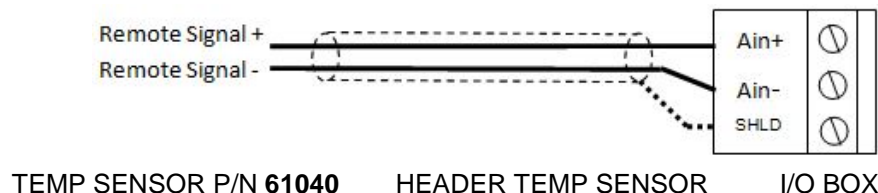


#### Step 2: Direct Wired 0-20ma or 4-20ma Wiring

1. Connect the 4-20ma or 0-20ma terminals from the Direct Drive source to the Ain+ and Ain- terminals on the Manager Unit's I/O Box.

**NOTE:**

- Shielded pair 18 - 22 AWG cable is recommended for this connection. Polarity must be observed.
- The ground for the shield is at the driver signal source.



(Continued)

**OPTION 5 - Remote Setpoint With Direct Wired Header Sensor And 4-20ma Setpoint Drive Instructions****Step 3: Configure ALL C-More Units****On ALL Boilers:**

1. Go to the *Configuration* menu and set the BST Menu item to **Enabled**.
2. Go to the Boiler Sequencing Menu and set the BST Mode item to **BST Client** (for now).

**On MANAGER only:**

3. Go to the BST Setpoint item and enter the Failsafe Setpoint.
4. Go to the BST Setup Menu item and set to **Enabled**.
5. Go to the BST Setpoint Mode item and select **Remote Setpoint**.
6. Go to the Head Temp Source item and select **FFWD Temp**.
7. Go to the BST Remote Signal and select either **4-20ma** or **0-20ma**.

**When ALL C-More units have been configured:**

8. Go to the Boiler Sequencing Menu of the Manager unit and set the BST Mode item to **BST MANAGER**.

### 6.3.6 OPTION 6 - REMOTE SETPOINT WITH DIRECT WIRED HEADER SENSOR AND MODBUS SETPOINT DRIVE

#### OPTION 6 - Remote Setpoint With Direct Wired Header Sensor And Modbus Setpoint Drive Instructions

**NOTE:**

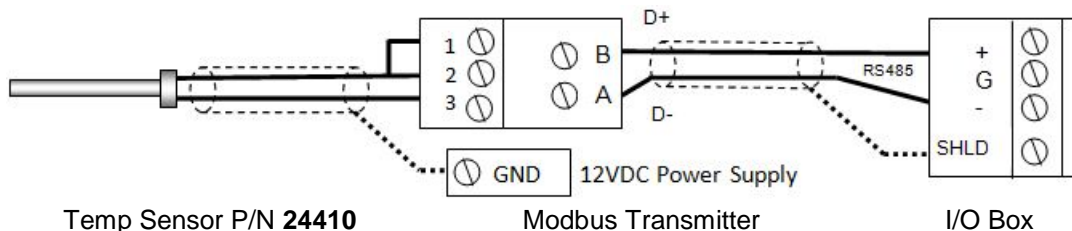
Both Header Sensor AND Outdoor Sensor must be wired. See the *C-More Controller User Manual*, OMM-0032 (GF-112) and *ProtoNode User Manual*, OMM-0080 (GF-129) for more information.

#### Step 1 - Modbus Header Sensor Wiring

1. Using Shielded pair 18 - 22 AWG cable, connect the Temperature Transmitter (P/N **65169**) terminal Pin B to the RS485+ terminal on the I/O Box of any of the Boiler units, and Pin A of the Temperature Transmitter to the RS485- terminal on the I/O Box of any of the Boiler units.
2. Using Shielded pair 18 - 22 AWG cable, connect the Modbus Header Temperature Sensor (P/N 24410) to pins 2 and 3 of the Temperature Transmitter.
3. Install a jumper wire between pins 1 and 2 of the Temperature Transmitter.

**NOTES:**

- Polarity must be observed for the RS485 connections. The ground for the shield is at the "SHLD" terminal in the I/O the Box.
- The header sensor must be installed between 2 and 10 feet (0.61 and 3.1m) downstream of the LAST boiler in the plant's supply water header.
- There is no polarity to be observed. The ground for the shield is at the power supply ground. The sensor end of the shield must be left free and ungrounded.



#### Step 2 - Modbus Outdoor Sensor Wiring

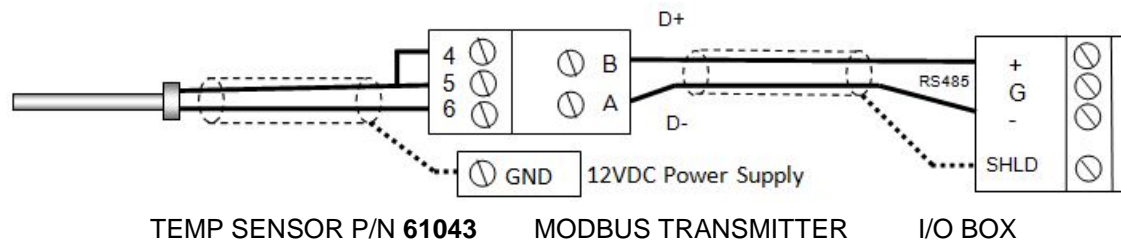
1. If you have not already done so when installing the Modbus Header Sensor, use Shielded pair 18 - 22 AWG cable to connect the Temperature Transmitter terminal Pin B to the RS485+ terminal on the I/O Box of any of the Boiler units, and Pin A of the Temperature Transmitter to the RS485- terminal on the I/O Box of any of the Boiler units.
2. Using Shielded pair 18 - 22 AWG cable, connect the Modbus Header Temperature Sensor (P/N 24410) to pins 2 and 3 of the Temperature Transmitter.
3. Install a jumper wire between pins 1 and 2 of the Temperature Transmitter.

(Continued)

## OPTION 6 - Remote Setpoint With Direct Wired Header Sensor And Modbus Setpoint Drive Instructions

### NOTES:

- Polarity must be observed for the RS485 connections. The ground for the shield is at the "SHLD" terminal in the I/O the Box.
- When mounting the Outdoor sensor, it must be located on the North side of the building where an average outside air temperature is expected. The sensor must be shielded from direct sunlight as well as impingement by the elements. The outdoor sensor may be wired up to 200 feet (61m) from the boiler.
- There is no polarity to be observed. The ground for the shield is at the power supply ground. The sensor end of the shield must be left free and ungrounded.



### Step 3 - Configure ALL C-More Units

#### On ALL Boilers:

1. Go to the *Configuration* menu and set the BST Menu item to **Enabled**.
2. Go to the Boiler Sequencing Menu and set the BST Mode item to **BST Client** (for now).

#### On MANAGER only:

3. Go to the BST Setpoint item and enter the Failsafe Setpoint.
4. Go to the BST Setup Menu item and set to **Enabled**.
5. Go to the BST Setpoint Mode item and select Outdoor Reset.
6. Go to the Head Temp Source item and select **Network**.
7. Go to the Header Temp Addr item and enter the Modbus Address (240).
8. Go to the Header Temp Point item and enter the Modbus Point (14).
9. Go to the BST Outdoor Sens item and select **Enabled**.
10. Go to the Outdoor Temp Source item and select **Network**.
11. Go to the Outdoor Temp Addr item and enter the Modbus Address (240).
12. Go to the Outdoor Temp Point item and enter the Modbus Point (15).

#### When ALL C-More units have been configured:

13. Go to the Boiler Sequencing Menu item of the Manager unit and set the BST Mode item to **BST MANAGER**.

### 6.3.7 OPTION 7 - REMOTE SETPOINT WITH MODBUS HEADER SENSOR AND 4-20MA SETPOINT DRIVE

#### OPTION 7 - Remote Setpoint With Modbus Header Sensor And 4-20ma Setpoint Drive Instructions

**NOTE:**

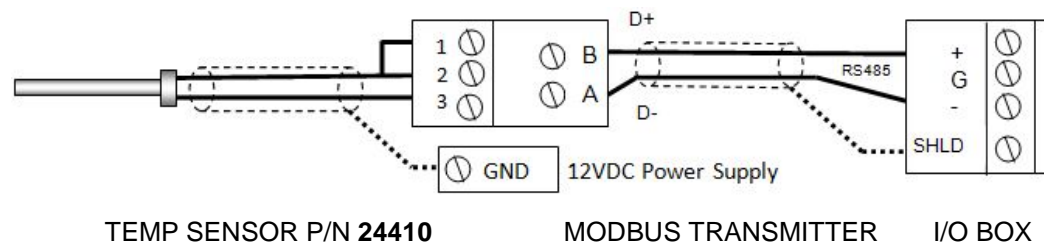
Both Header Sensor AND 4-20ma Direct Drive must be wired. See the *C-More Controller User Manual*, OMM-0032 (GF-112) and *ProtoNode User Manual*, OMM-0080 (GF-129) for more information.

##### Step 1: MODbus Header Sensor

1. Using Shielded pair 18 - 22 AWG cable, Connect the Temperature Transmitter (P/N **65169**) terminal Pin B to the RS485+ terminal on the I/O Box of any of the Boiler units, and Pin A of the Temperature Transmitter to the RS485- terminal on the I/O Box of any of the Boiler units.
2. Using Shielded pair 18 - 22 AWG cable, connect the Modbus Header Temperature Sensor (P/N 24410) to pins 2 and 3 of the Temperature Transmitter.
3. Install a jumper wire between pins 1 and 2 of the Temperature Transmitter.

**NOTES:**

- Polarity must be observed for the RS485 connections. The ground for the shield is at the "SHLD" terminal in the I/O the Box.
- The header sensor must be installed between 2 and 10 feet (0.61 and 3.1m) downstream of the LAST boiler in the plant's supply water header.
- There is no polarity to be observed. The ground for the shield is at the power supply ground. The sensor end of the shield must be left free and ungrounded.

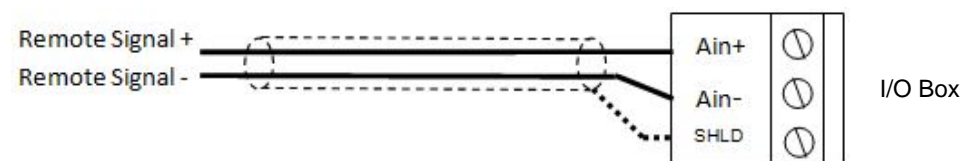


##### Step 2: Direct Wired 0-20ma or 4-20ma Wiring

1. Connect the 4-20ma or 0-20ma terminals from the Direct Drive source to the Ain+ and Ain- terminals on the Manager.

**NOTES:**

- Unit's I/O Box. Shielded pair 18 - 22 AWG cable is recommended for this connection. Polarity must be observed.
- The ground for the shield is at the driver signal source.



(Continued)

**OPTION 7 - Remote Setpoint With Modbus Header Sensor And 4-20ma Setpoint Drive Instructions****Step 3: Configure ALL C-More Units****On ALL Boilers:**

1. Go to the *Configuration* menu and set the BST Menu item to **Enabled**.
2. Go to the Boiler Sequencing Menu and set the BST Mode item to **BST Client** (for now).

**On MANAGER only:**

3. Go to the BST Setpoint item and enter the Failsafe Setpoint.
4. Go to the BST Setup Menu item and set to **Enabled**.
5. Go to the BST Setpoint Mode item and select **Remote Setpoint**.
6. Go to the BST Remote Signal and select either 4-20ma or 0-20ma.
7. Go to the Head Temp Source item and select **Network**.
8. Go to the Header Temp Addr item and enter the Modbus Address (240).
9. Go to the Header Temp Point item and enter the Modbus Point (14).

**When ALL C-More units have been configured:**

10. Go to the Boiler Sequencing Menu of the Manager unit and set the BST Mode item to **BST MANAGER**.



### 6.3.8 Option 8 - Remote Setpoint with MODBUS Header Sensor AND MODBUS Setpoint Drive

#### OPTION 8 - Remote Setpoint With Modbus Header Sensor And Modbus Setpoint Drive Instructions

**NOTE:**

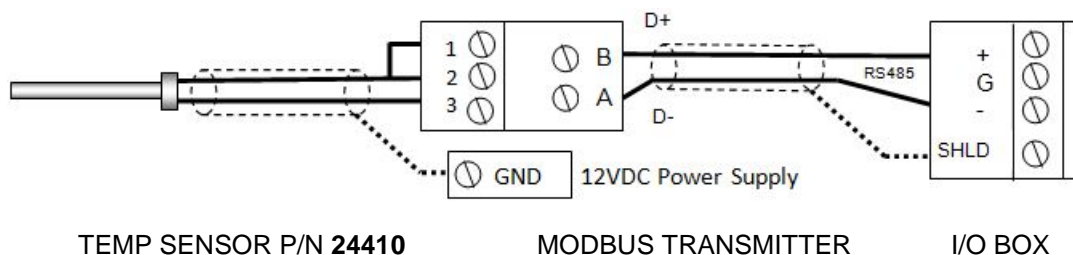
Both Header Sensor AND ProtoNode SSD Device must be wired. See the *C-More Controller User Manual*, OMM-0032 (GF-112) and *ProtoNode User Manual*, OMM-0080 (GF-129) for more information.

##### Step 1: MODbus Header Sensor

1. Using Shielded pair 18 - 22 AWG cable, Connect the Temperature Transmitter (P/N 65169) terminal Pin B to the RS485+ terminal on the I/O Box of any of the Boiler units, and Pin A of the Temperature Transmitter to the RS485- terminal on the I/O Box of any of the Boiler units.
2. Using Shielded pair 18 - 22 AWG cable, connect the Modbus Header Temperature Sensor (P/N 24410) to pins 2 and 3 of the Temperature Transmitter.
3. Install a jumper wire between pins 1 and 2 of the Temperature Transmitter.

**NOTE:**

- Polarity must be observed for the RS485 connections. The ground for the shield is at the "SHLD" terminal in the I/O the Box.
- The header sensor must be installed between 2 and 10 feet (0.61 and 3.1m) downstream of the LAST boiler in the plant's supply water header.
- There is no polarity to be observed. The ground for the shield is at the power supply ground. The sensor end of the shield must be left free and ungrounded.



##### Step 2: Remote Setpoint with Network

1. Configure and Connect the SSD Device (ProtoNode) per the *ProtoNode User Manual*, OMM-0080 (GF-129).

(Continued)

**OPTION 8 - Remote Setpoint With Modbus Header Sensor And Modbus Setpoint Drive Instructions****Step 3: Configure ALL C-More Units****On ALL Boilers:**

1. Go to the *Configuration* menu and set the BST Menu item to **Enabled**.
2. Go to the Boiler Sequencing Menu and set the BST Mode item to **BST Client** (for now).

**On MANAGER only:**

3. Go to the BST Setpoint item and enter the failsafe Setpoint.
4. Go to the BST Setup Menu item and set to **Enabled**.
5. Go to the BST Setpoint Mode item and select **Remote Setpoint**.
6. Go to the BST Remote Signal and select either Network.
7. Go to the Head Temp Source item and select **Network**.
8. Go to the Header Temp Addr item and enter the Modbus Address (240).
9. Go to the Header Temp Point item and enter the Modbus Point (14).

**When ALL C-More units have been configured:**

10. Go to the Boiler Sequencing Menu of the Manager unit and set the BST Mode item to **BST MANAGER**.

## SECTION 7: onAER SETUP

### 7.1 INTRODUCTION

AERCO has developed new connectivity capabilities to make its IoT offering, onAER, easier for its broad customer base to implement. The onAER feature lets you monitor your AERCO boilers and water heaters remotely. As in the past, AERCO has taken precautions to make onAER secure for both the customer's heating equipment and networks.

All Benchmark Platinum boilers include AERCO's onAER feature.

onAER communication can be established in one of two ways:

- Through an Ethernet cable from the site's network plugged into the WIZnet card on the unit's I/O board. This card is standard equipment on all Benchmark Platinum boilers.
- Wirelessly via Wi-Fi. This solution requires the purchase and installation of the optional AERCO Wi-Fi module (P/N **24526-2** for BMK 750 & 1000, and **24526-1** for BMK 1500 – 6000). This module is then connected directly to the boiler's I/O board, eliminating the need for an Ethernet cable. The WIZnet card remains in place but is not used.

#### NOTE

In addition, AERCO offers a Wi-Fi Router as an option for sites that have difficulty receiving the Wi-Fi signal.

The sections below provide instructions for implementing only the first option, enabling communication through an Ethernet cable connected to the site's network. If you ordered a Benchmark Platinum boiler with the Wi-Fi module, it is included in a separate container inside the unit's shipping container. The instructions for installing both the Wi-Fi module and optional Wi-Fi Router are in Technical Instruction document TID-0178, included with the module.

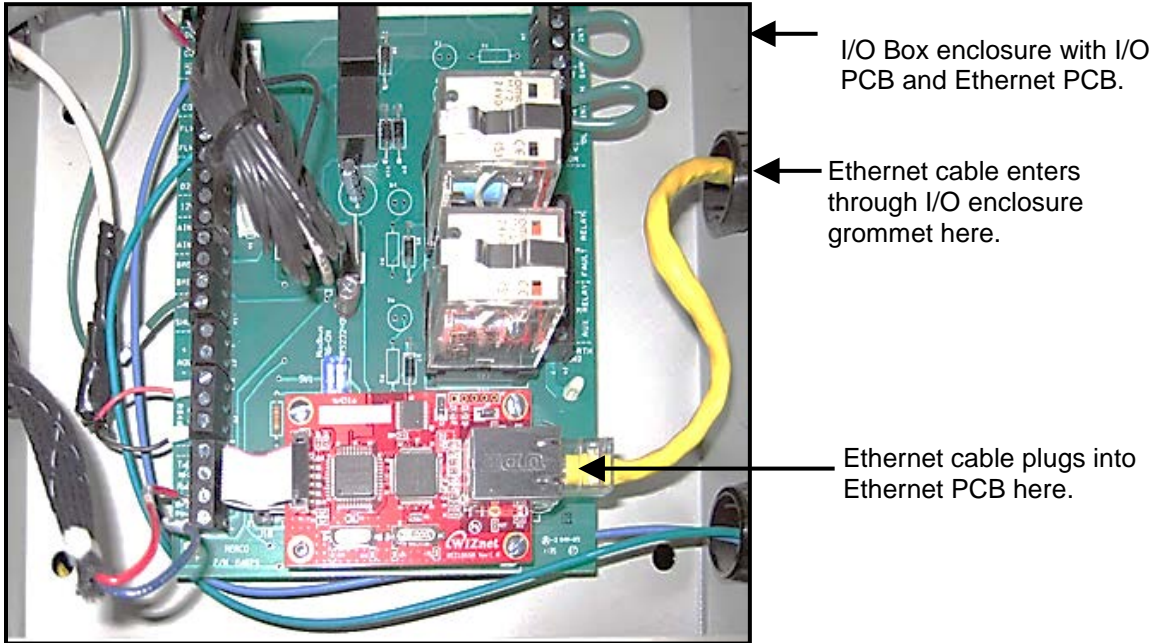
If you did *not* order the Wi-Fi module but are now interested in it, contact your AERCO representative and ask about purchasing the Wi-Fi module (P/N **24526-TAB**) and optional Wi-Fi Router (P/N **69038**).

#### 7.1.1 Connecting the Ethernet Cable

##### Connecting The Ethernet Cable Instructions

1. Connect a CAT 5 or better Ethernet cable to the wall jack or box provided at the site.
2. Route the Ethernet cable to the I/O box, avoiding hot locations.
3. Route the Ethernet cable into the I/O box through one of the plastic grommets on the side of the I/O box.
4. Connect the Ethernet cable to the Ethernet jack in the I/O box (tab down). See Figure 7-1.

### Connecting The Ethernet Cable Instructions



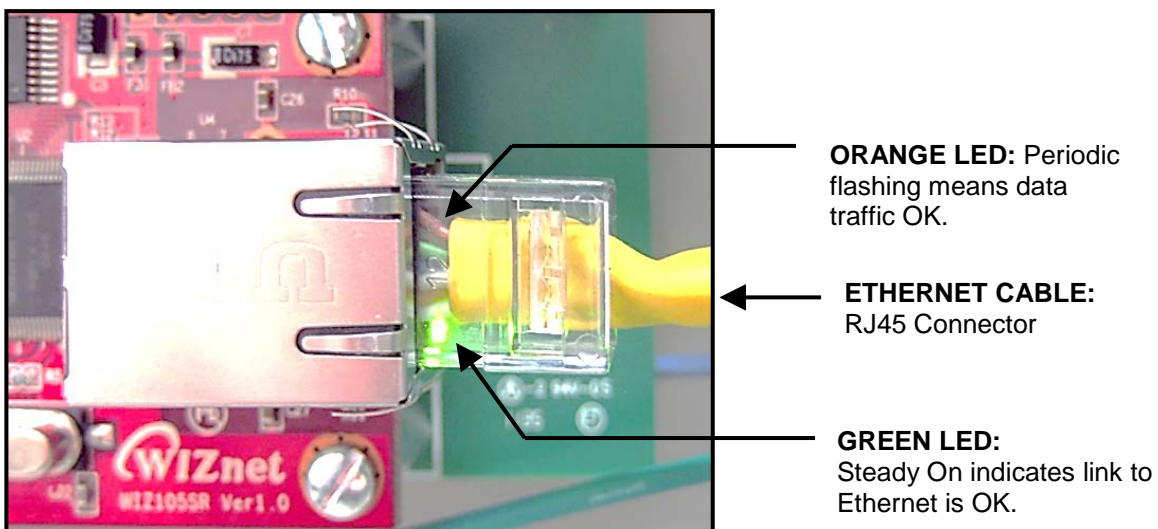
*Figure 7-1: I/O Box Interior Showing Ethernet Cable & OnAER PCB*

### 7.1.2 Confirming the Ethernet Connection

Refer to Figure 7-2, below, and complete the following instructions to confirm that the Ethernet cable connection is working.

#### Confirming The Ethernet Connection Instructions

1. With the unit powered on, look at the two LED lights (green and orange) on the (Red) onAER Communications Ethernet card at the bottom edge of the RJ45 connector - this is the silver-metal rectangular receptacle.
2. The green LED should be on steadily - this indicates that you are connected to the LAN (Local Area Network).
3. The orange light should blink periodically, indicating that there is normal traffic on the network.



*Figure 7-2: Ethernet Link and Data Traffic LEDs*

### 7.1.3 Confirm Ethernet DHCP Configuration

Once you have confirmed that the Ethernet connection is working, complete the following steps to confirm that the connection is active.

#### Confirming Ethernet DHCP Configuration Instructions

1. Connect your computer to the network jack that will be used by the C-More Controller. Your computer should be configured to automatically get a network address. Boot or reboot your computer.
2. Open a web browser (e.g., Internet Explorer) and go to [www.google.com](http://www.google.com).
3. Confirm that you can access the Google home page without entering a password. This confirms that the connection is active, provides DHCP addresses, and allows access without the need for a password.

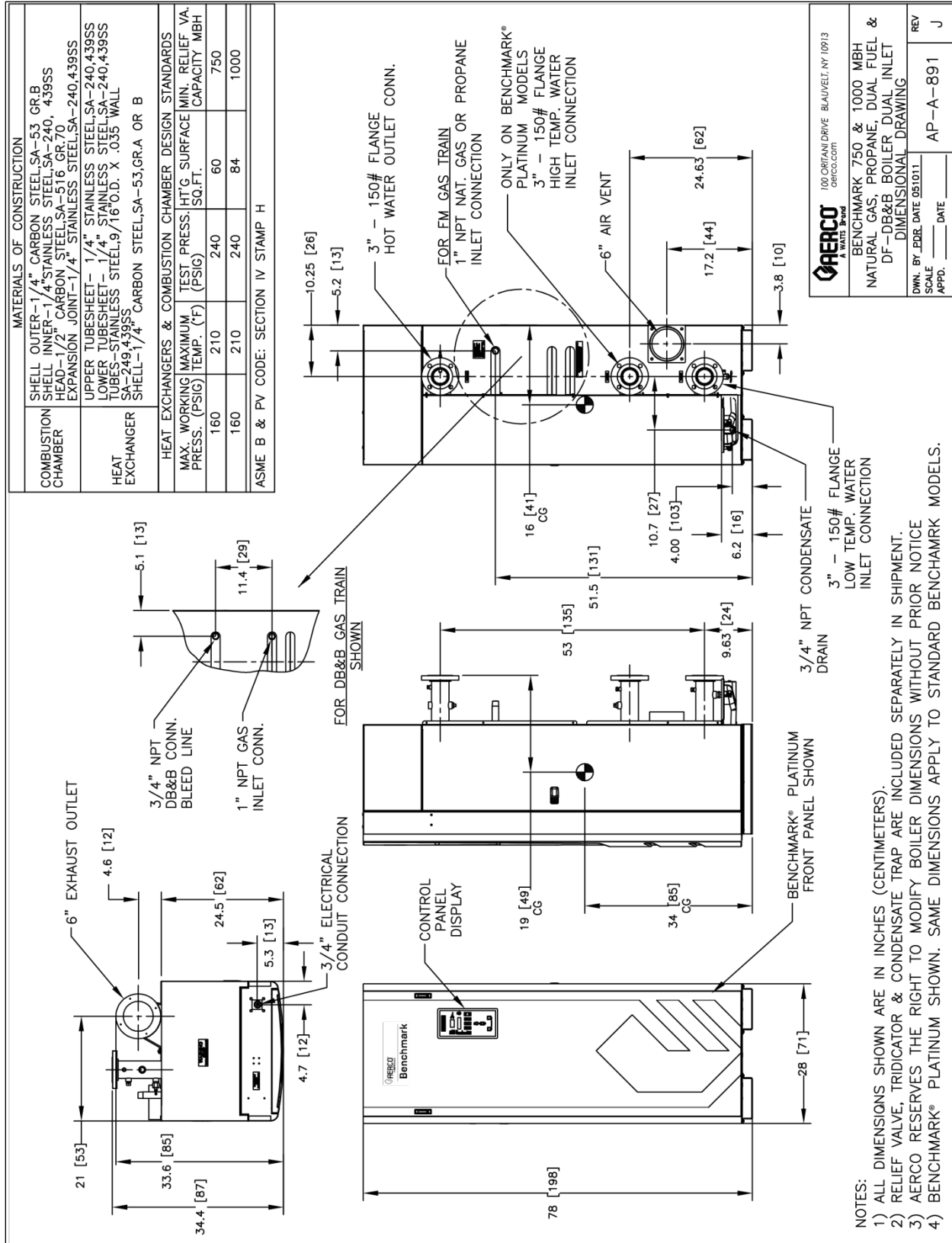
**NOTE**

Static addresses are not required or recommended by AERCO. Reserved addresses are a simpler solution.

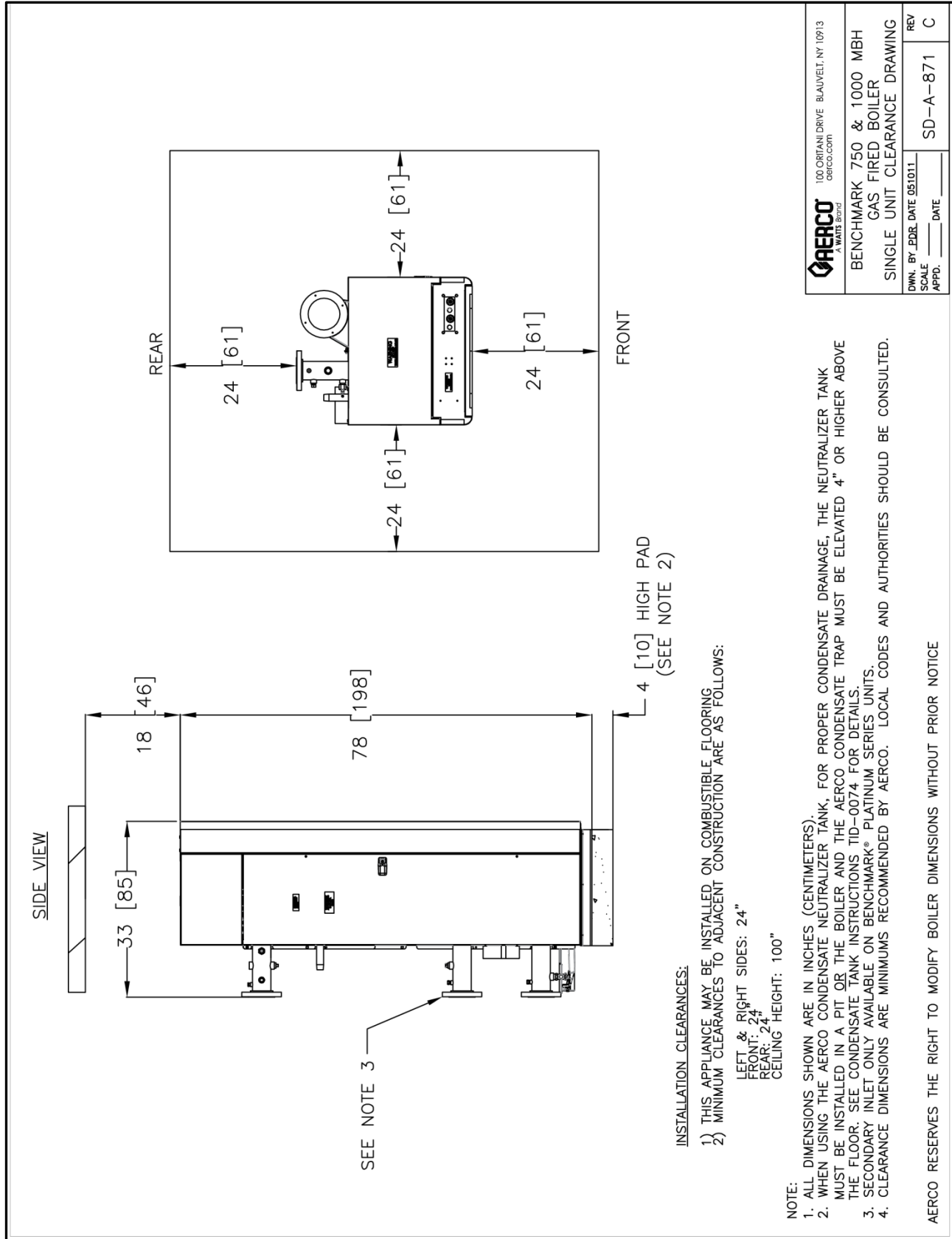
(This page intentionally blank)



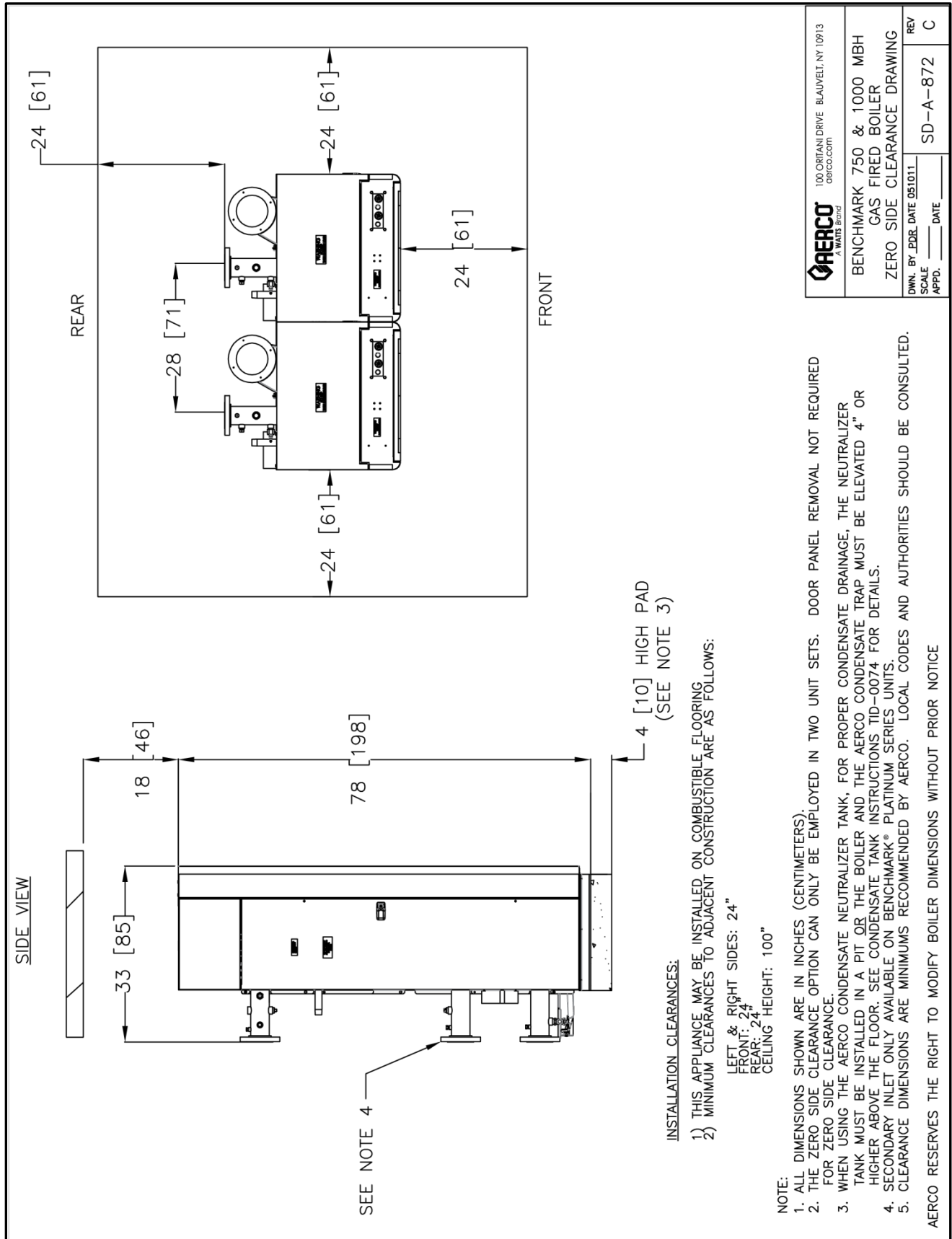
Appendix A: Dimensional and Clearance Drawings



Benchmark 750/1000 Dimension Drawing AP-A-891 rev J



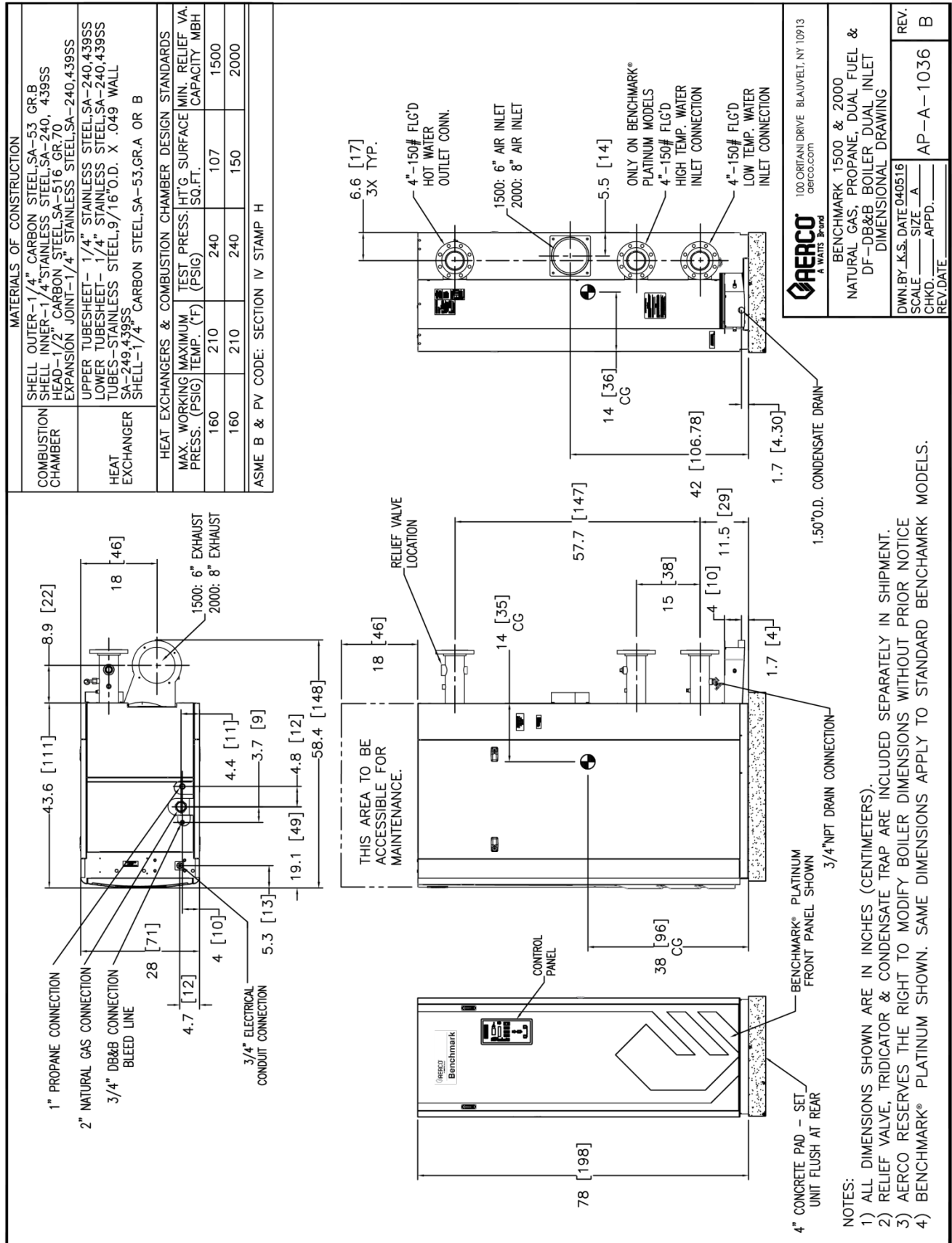
Benchmark 750/1000 Single Unit Clearance Drawing SD-A-871 rev C



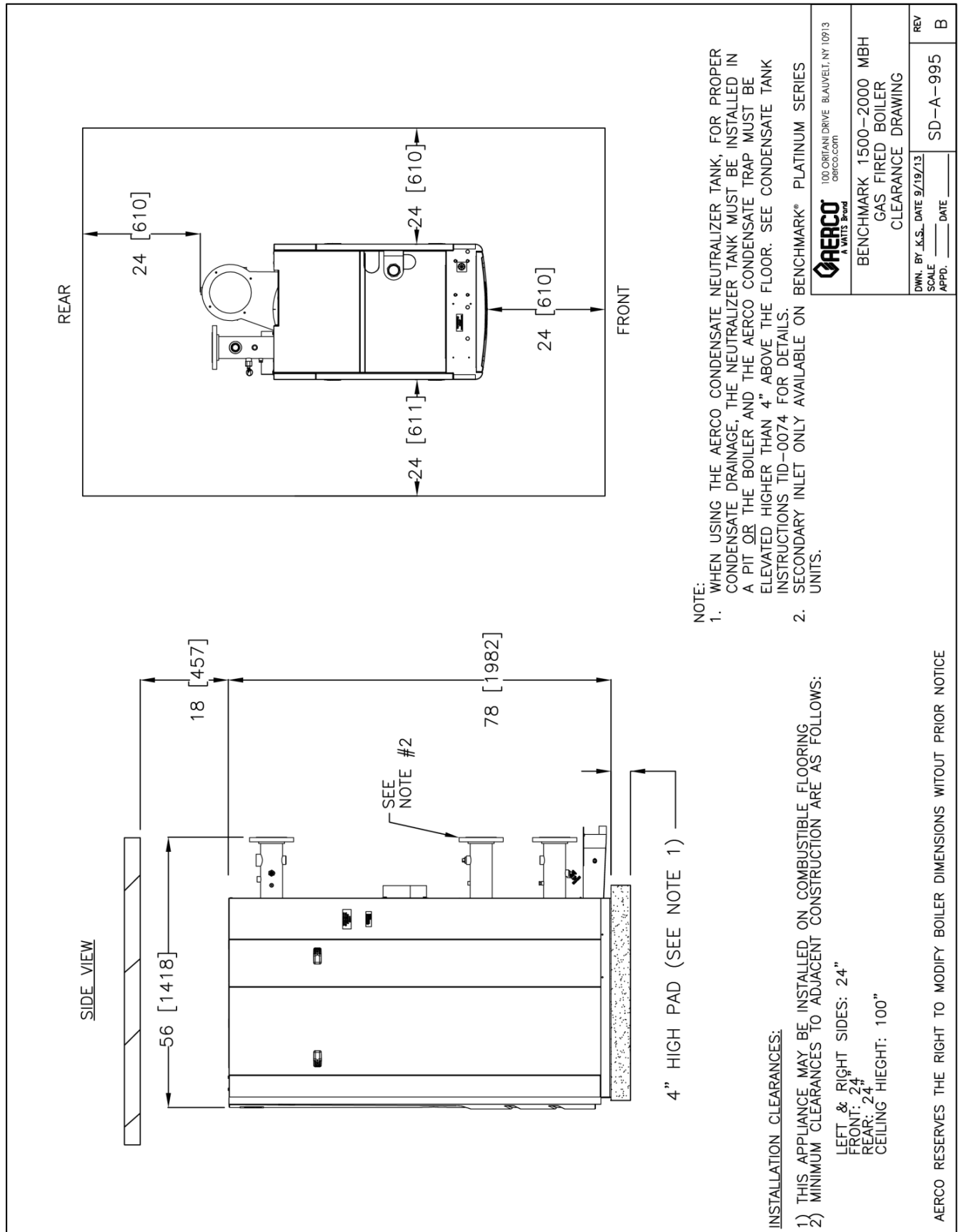
Benchmark 750/1000 Zero Side Clearance Drawing SD-A-872 rev C

<p>100 ORITANI DRIVE BLAUVELT, NY 10913 aerco.com</p>	<p>BENCHMARK 750 &amp; 1000 MBH GAS FIRED BOILER ZERO SIDE CLEARANCE DRAWING</p>	<p>REV C</p>
	<p>DWN. BY: _____ DATE: _____</p>	<p>SCALE: _____</p>

## APPENDIX A – DIMENSIONAL AND CLEARANCE DRAWINGS



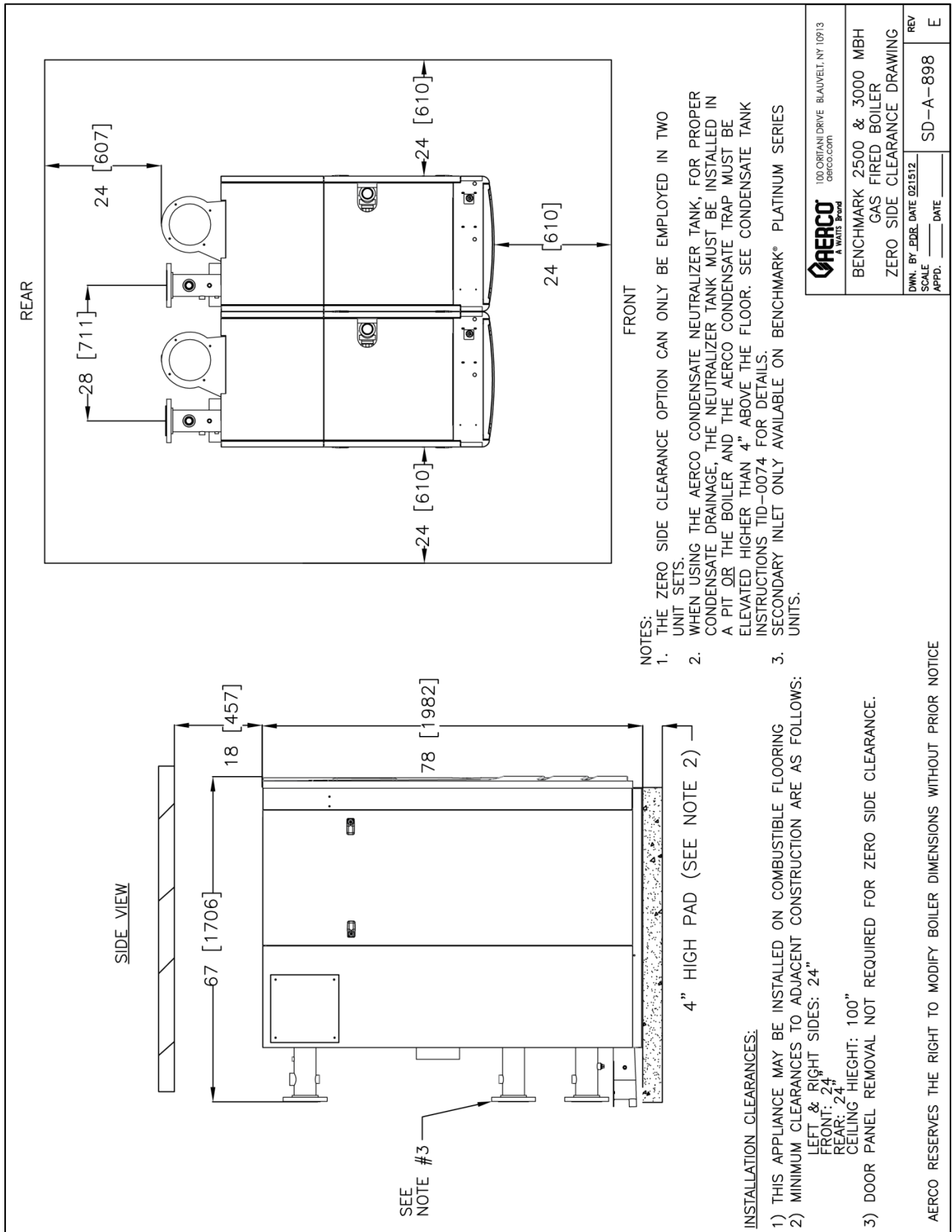
Benchmark 1500/2000 Dimension Drawing Number: AP-A-1036 rev B



Benchmark 1500/2000 Clearance Drawing Number: SD-A-995 rev B







Benchmark 2500/3000 Clearance Drawing Number: SD-A-898 rev E

**Change Log:**

Date	Description	Changed By
07/17/2017	<p><b>Rev B:</b>  <b>DIR 17-033:</b> Corrected text in section 5.7 Flame Fault Test  <b>DIR 17-050:</b> Corrected target values in Section 4, Combustion Calibration, added missing values for Dual Fuel models, modified step 4 in Section 5.2.2 and step 3 5.3.2.</p>	Chris Blair
11/29/2017	<p><b>Rev C:</b>  <b>DIR 17-065:</b> Changed minimum gas pressure for BMK 1500/2000 to 4' W.C. in Table 2-2, section 2.9.1  <b>DIR 17-080:</b> Verified part numbers throughout the manual, standardized C-More Controller naming convention.</p>	Chris Blair



© AERCO International, Inc., 2017