

Covers all 1B+ II models including units with *pneumatically* controlled valve (Type CXT-P) or with an Electronic Control System (ECS) and *electronically* controlled valve (CXT-E):

- B+03
- B+04
- B+05
- B+06
- B+07
- B+08
- B+09
- B+10
- B+11
- B+12
- B+13
- B+14
- B+15

**Note:** Number indicates number of heating coils used (3 to 15).

**Other applicable documentation includes:**

SB-2006-02: ECS Retrofit Instructions

AC-105: Electronic Controls System (ECS) Manual

AC-103: Pneumatic Temperature Controller Manual

Revised: 11/28/2018

# USER MANUAL

Installation, Operation, and Maintenance

## Water Wizard 1B+ II Water Heaters



***SW1B+II Packaged Water Heater with  
Pneumatically Controlled Valve (CXT-P)***



**Technical Support:**  
(Mon–Fri, 8am-5pm EST)  
**1-800-526-0288**

[www.aerco.com](http://www.aerco.com)

### **Disclaimer**

The information contained in this manual is subject to change without notice from AERCO International, Inc. AERCO makes no warranty of any kind with respect to this material, including but not limited to implied warranties of merchantability and fitness for a particular application. AERCO International is not liable for errors appearing in this manual. Nor for incidental or consequential damages occurring in connection with the furnishing, performance, or use of this material.

**TABLE OF CONTENTS**

**CHAPTER 1. SAFETY PRECAUTIONS ..... 5**

**CHAPTER 2. GENERAL INFORMATION ..... 6**

    2.1. MODEL NAMES .....6

    2.2. HEAT EXCHANGER CONFIGURATIONS .....6

    2.3. ACCESSORIES .....6

    2.4. ALL OTHER ITEMS.....7

**CHAPTER 3. INSTALLATION ..... 12**

    3.1. INSTALLING THE WATER WIZARD .....12

**CHAPTER 4. PRINCIPLE OF OPERATION ..... 17**

    4.1. HEAT EXCHANGER OPERATION WITH PNEUMATIC CONTROL .....17

    4.2. HEAT EXCHANGER OPERATION WITH ELECTRONIC CONTROL SYSTEM (ECS) .....18

**CHAPTER 5. OPERATING PROCEDURES ..... 19**

**CHAPTER 6. ROUTINE MAINTENANCE..... 22**

    6.1. DRAINING THE HEATER .....22

    6.2. CHECKING THE DRAINED WATER .....22

    6.3. CHECKING THE TEMPERATURE CONTROL.....22

**CHAPTER 7. TROUBLESHOOTING ..... 23**

**CHAPTER 8. CORRECTIVE MAINTENANCE ..... 24**

**CHAPTER 9. DE-SCALING BY THERMAL SHOCK METHOD..... 26**

**CHAPTER 10. MAINTENANCE DISASSEMBLY ..... 27**

    10.1. TOOLS AND EQUIPMENT .....27

        10.1.1. *Common Tools and Equipment* .....27

        10.1.2. *SPECIAL TOOLS AND EQUIPMENT REQUIRED:* .....27

    10.2. ISOLATING THE HEATER .....29

    10.3. DISCONNECTING THE HEATER FROM THE FACILITY .....30

    10.4. ANTICIPATOR CHECK VALVE DISASSEMBLY .....31

        10.4.1. *Special Tools Required*.....31

    10.5. PREPARING TO REMOVE THE HEATER SHELL .....32

    10.6. REMOVING THE HEATER SHELL.....33

    10.7. REMOVING COILS AND RISERS .....33

**CHAPTER 11. CLEANING AND INSPECTION ..... 34**

    10.8. PREPARATION OF BOTTOM HEAD .....34

    10.9. PREPARATION OF RISER AND RETURN .....34

    10.10. PREPARATION OF COIL ASSEMBLIES .....35

    10.11. PREPARATION OF COIL GASKETS.....37

**CHAPTER 12. MAINTENANCE REASSEMBLY ..... 38**

    12.1. REASSEMBLY OF RISERS, SUB-COOLING COIL, AND STEAM COILS .....38

        12.1.1. *Riser Installation* .....38

    12.2. SUB-COOLING COIL INSTALLATION .....40

        .....40

    12.3. STEAM COIL INSTALLATION .....40

    12.4. HYDROSTATICALLY TESTING COILS & RISERS .....42

    12.5. ANTICIPATOR CHECK VALVE REASSEMBLY .....42

    12.6. REASSEMBLY OF SHELL.....43

    12.7. REINSTALLING HEATER IN FACILITY .....43

    12.8. STARTUP PROCEDURE.....43

**CHAPTER 13. RECOMMENDED SPARE PARTS ..... 44**

## CHAPTER 1. SAFETY PRECAUTIONS

Installing or operating personnel must, at all times, observe all safety regulations. The following warnings are general and must be given the same attention as specific precautions included in the instructions.



**FLUIDS UNDER PRESSURE MAY CAUSE INJURY TO PERSONNEL OR  
DAMAGE TO EQUIPMENT WHEN RELEASED.**

SHUT OFF ALL INCOMING AND OUTGOING STEAM AND HOT WATER STOP VALVES AND  
CAREFULLY DECREASE ALL TRAPPED PRESSURES TO ZERO (see SHUTDOWN IN  
OPERATING PROCEDURES) BEFORE PERFORMING ANY MAINTENANCE.



**LIVE STEAM CAN CAUSE SEVERE BURNS.**

NEVER SEARCH FOR LEAKAGE IN A LIVE STEAM LINE BY SIGHT ALONE OR BY "FEEL." USE A  
MIRROR OR OTHER SUITABLE POLISHED OBJECT. ALSO, ALWAYS WEAR GLOVES AND LONG  
SLEEVES.

## CHAPTER 2. GENERAL INFORMATION

This instruction covers the AERCO Helitherm Model B+II WATER WIZARD Steam to Water Heat Exchangers. STEAM is the PRIMARY or TUBE SIDE FLUID. The WATER BEING HEATED is the Heat Exchanger (service or domestic water or other fluid) is the SECONDARY or SHELL SIDE FLUID.

### 2.1. MODEL NAMES

The number of coils in a particular Heat Exchanger is denoted by the two digits following the “B+” in the Heat Exchanger Model Number. That is: B+03 = 3 coils, B+07 = 7 coils, B+11 = 11 coils, and B+15 = 15 coils.

The Style designation for a Heat Exchanger denotes materials of construction for the various components of the assembly. If this information is required for a specific Heat Exchanger, contact the nearest AERCO Sales Representative.

### 2.2. HEAT EXCHANGER CONFIGURATIONS

There are three basic heat exchanger configurations; those with a pneumatically controlled valve (CXT-P), those with Electronic Control System (ECS) with an electronically controlled valve (CXT-E), and a “bare” heat exchanger without controls or valve. See separate ECS Controls manual, **AC-105**, for information about the Electronic controls System and electronically operated CXT-E valve. See **Section 3** for available accessories.

### 2.3. ACCESSORIES

Accessories included in the AERCO B+II Heater Package Assembly (See Figures 1a, 1b, 1c, 21, 22, and 23) include:

- Steam Flow Control Valve – either Air-Operated or Self-Contained as ordered and furnished, sized as required for the service.
- Temperature Controller – installed in the Control Box when an Air Operated Control Valve is furnished (See Fig. 20, Item 134).
- Over-Temperature Limit System, including the following:
- Temperature Switch – installed in the Control Box (Figure 20, Item 126).
- Solenoid Valves:
  - Water – installed in the Heater Top Head.
  - Air – installed in the Control Box when an Air Operated Control Valve is furnished (Fig. 20, Item 135).
  - Steam – installed on the Self-Contained Control Valve when such valve is furnished.
  - Indicator Lights: “Power On” and “Tripped” – installed in the Control Box (Figure 20, Items 129 and 130).
- Steam Compound Pressure Gage – mounted below the Control Box (Figure 20, Item 133).
- Shell Hot Water Outlet Temperature Gage – mounted below the Control Box (Figure 20, Item 132).

- Pressure & Temperature Relief Valves – size and number furnished as required in accordance with the design BTU output of the heater – first two located in the heater Top Head as shown in Figure 1a, 1b, 1c, and 1d. The third, if furnished, to be installed in the hot water outlet piping by the user as shown in Figure 2.
- Union Orifice – located in the Condensate Outlet (Figure 12, Item 55) – required in place of a steam trap to ensure complete condensation of the steam within the heater.
- Check Valve – located in the Condensate Outlet (Figure 12, Item 53).

## **2.4. ALL OTHER ITEMS**

Stop valves, check valves, strainers, unions or flanges, and other piping and fittings as shown in Figures 3 through 6 – are to be furnished by USER.

### **NOTE:**

This instruction covers only the heat exchanger portion of the model B+II packaged heater assembly. Separate instructions are included in this package covering steam control valve, the over-temperature limit system and its components, and other accessories included in the heater package.

### **NOTE:**

The AERCO Helitherm heat exchanger carries the standard AERCO warranty against defective material and workmanship. However, AERCO cannot honor its warranty if the installer or user deviates in any way from the instructions and precautions included herein and/or make any alteration of the equipment from that furnished without the written approval of AERCO.

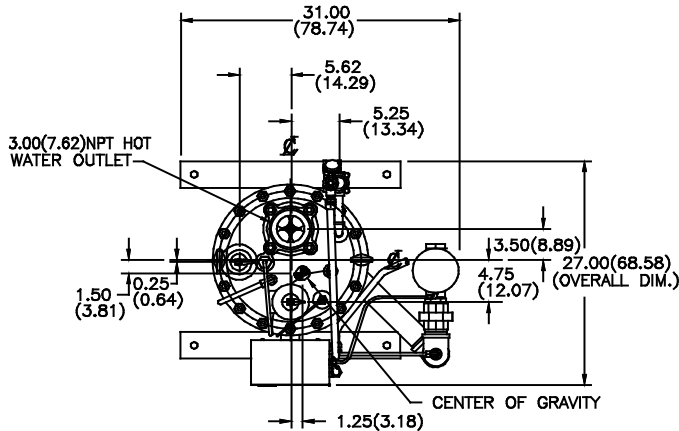

CONTROL VALVE SIZE	"C" DIMENSION
	IN. (CM.)
1" (2.54) SCREWED END	26.00 (66.00)
1-1/4" (3.18) SCREWED END	26.00 (66.00)
1-1/2" (3.81) SCREWED END	26.00 (66.00)
2" (5.08) SCREWED END	26.00 (66.00)
2-1/2" (6.35) 150# ANSI FLANGED END	31.00 (78.74)
3" (7.62) 150# ANSI FLANGED END	31.00 (78.84)
4" (10.16) 150# ANSI FLANGED END	31.00 (78.84)

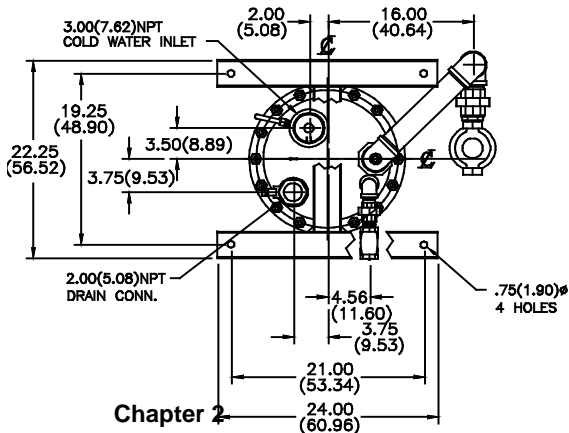
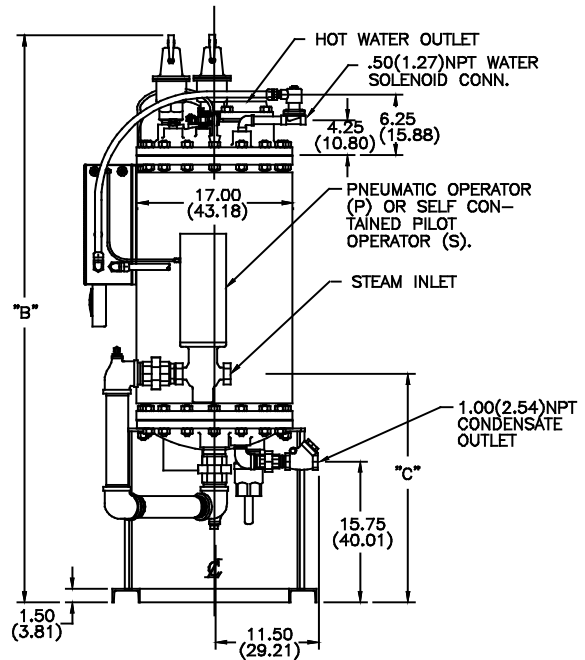
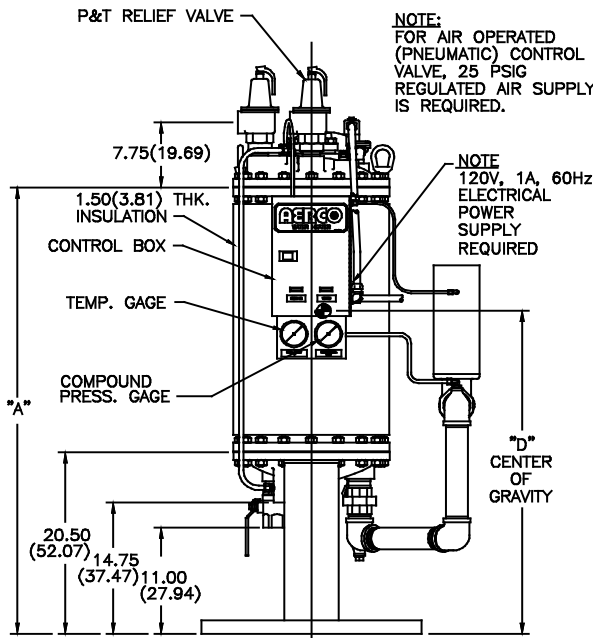

**Chapter 2**  
**General Information**  
 DIMENSIONS SHOWN ARE IN INCHES.  
 DIMENSIONS IN ( ) ARE IN CENTIMETERS.

HEATER MODEL	NO. OF COILS	HEATING SURF. SQ.FT.(SQ.M.)	DIM. IN.(CM)			WT. LBS.(Kg)	
			"A"	"B"	"D"	DRY	WET
B+03	3	15 (1.39)	41.38 (105.11)	55.00 (139.70)	27.38 (69.55)	460 (209)	600 (272)
B+04	4	20 (1.85)	50.38 (127.97)	64.00 (162.56)	31.88 (80.99)	535 (243)	700 (318)
B+05	5	25 (2.32)	50.38 (127.97)	64.00 (162.56)	31.88 (80.99)	550 (250)	710 (322)
B+06	6	30 (2.78)	59.38 (150.83)	73.00 (185.42)	36.38 (92.41)	595 (270)	810 (368)
B+07	7	35 (3.25)	59.38 (150.83)	73.00 (185.42)	36.38 (92.41)	610 (277)	820 (372)
B+08	8	40 (3.71)	68.38 (173.69)	82.00 (208.28)	40.88 (103.84)	665 (302)	910 (413)
B+09	9	45 (4.18)	68.38 (173.69)	82.00 (208.28)	40.88 (103.84)	680 (309)	920 (418)
B+10	10	50 (4.63)	77.38 (196.55)	91.00 (231.14)	45.38 (115.27)	725 (329)	1010 (459)
B+11	11	55 (5.11)	77.38 (196.55)	91.00 (231.14)	45.38 (115.27)	740 (336)	1020 (463)
B+12	12	60 (5.56)	86.38 (219.41)	100.00 (254.00)	49.88 (126.70)	795 (361)	1110 (504)
B+13	13	65 (6.04)	86.38 (219.41)	100.00 (254.00)	49.88 (126.70)	810 (368)	1120 (508)
B+14	14	70 (6.49)	95.38 (242.27)	109.00 (276.86)	54.38 (138.13)	855 (388)	1210 (550)
B+15	15	75 (6.97)	95.38 (242.27)	109.00 (276.86)	54.38 (138.13)	870 (395)	1220 (554)

NOTE: CENTER OF GRAVITY IS WITHOUT VALVE LINE.

**Figure 1a – Dimensions for AERCO Helitherm Heat Exchanger (Packaged Water Heater), Model Water Wizard SW1B+II with Pneumatic CXT-P Valve**



# 1B+ II Water Wizard Water Heaters

Installation, Operation & Maintenance Manual

HE-110

OMM-0063\_0D

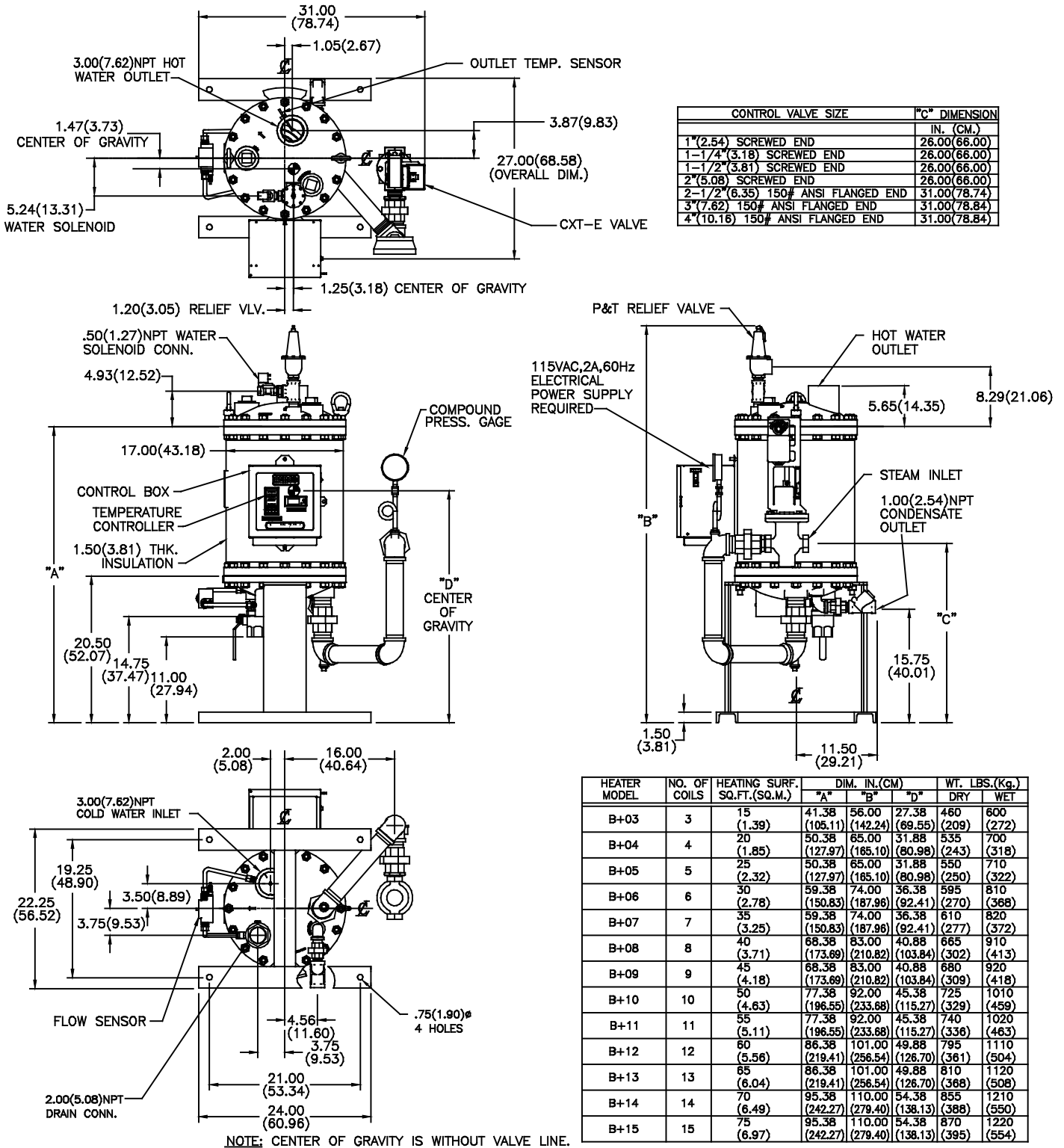

Figure 1b – Dimensions for AERCO Helitherm Heat Exchanger (Packaged Water Heater), Model Water Wizard SW1B+II with Bronze Heads, ECS, and CTX-E Valve

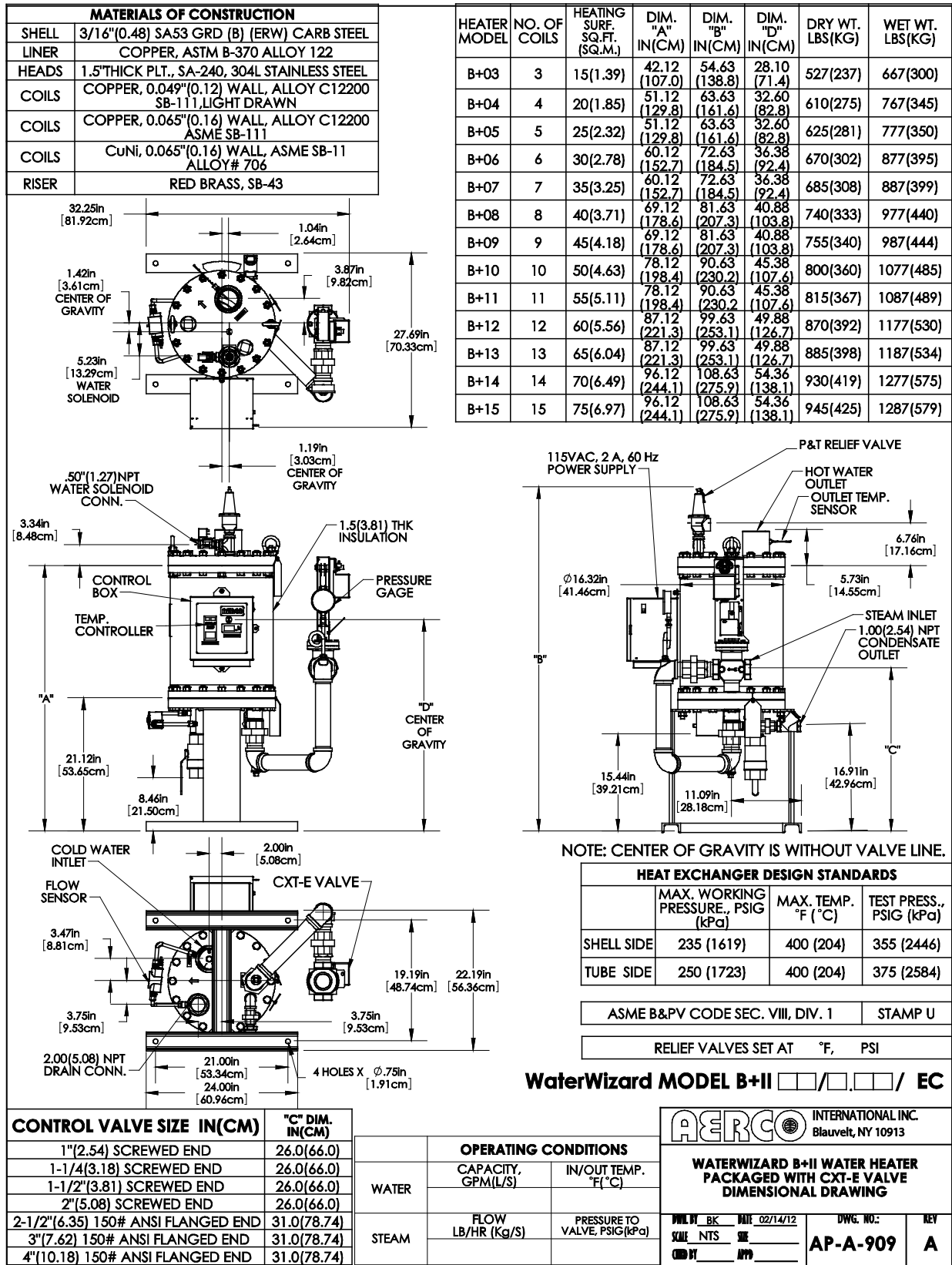

Figure 1c – Dimensions for AERCO Helitherm Heat Exchanger (Packaged Water Heater), Model Water Wizard SW1B+II with Stainless Steel Heads, ECS, and CTX-E Valve

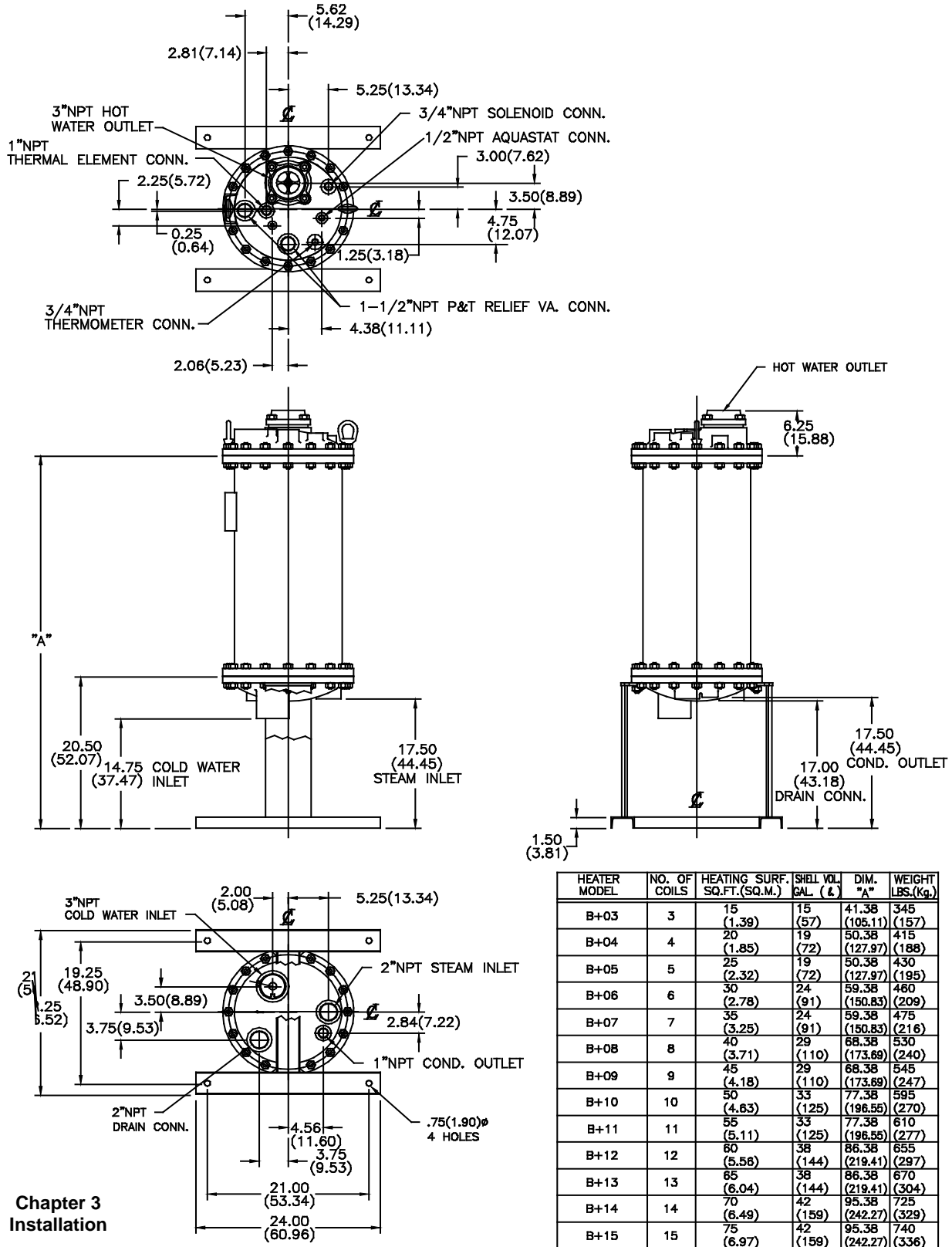

Figure 1d – Dimensions for AERCO Bare Helitherm Replacement Heat Exchanger for Model Water Wizard SW1B+II

## CHAPTER 3. INSTALLATION

### 3.1. INSTALLING THE WATER WIZARD

To install the Water Wizard SW1B+II water Heater, follow the steps below:

#### Installing the Water Wizard Heater Instructions

- 1) Dimensions for three versions of AERCO Model SW1B+II are shown in Figures 1a, 1b, and 1c.
- 2) Uncrate the Heater carefully. Set the Heater upright by using a block and tackle or hoist attached to the lifting lug on the top of the Heater (the eye-bolts shown in Figure 15). Always use the lifting lugs to lift and/or move the Heater.
- 3) If possible, for easy in-place maintenance, locate the Heater where there is at least 2 feet clearance all around the Heater and where the head room clearance from the top of dimension B in Figure 1 is at least equal to dimension A for the Heater Model, less 24 inches.
- 4) It is suggested that the Heater stand assembly be secured to the floor, however, any other means for securing the Heater may be used. If piping is used to secure the Heater, the piping must include ample provision for expansion.
- 5) Make all piping connections as instructed in Step 6 below and per the appropriate Figures shown:
  - a) Single Heater – Figure 3
  - b) Parallel Heaters – Figure 4
  - c) Single Heater used with an Accumulator – Figure 5
  - d) Single Heater used with a Stratified Storage Tank – Figure 6or with any specific piping diagram which may have been furnished by AERCO for this installation.
- 6) For the best Heater performance, OBSERVE THE FOLLOWING VERY CAREFULLY in making the piping installation:
  - a) Do not use cement or red lead in making up pipe joints
  - b) For Heater connection types, sizes, and exact locations, see Figure 1.
  - c) All piping to the Heater top head should be provide with unions or flanges which are LOCATED BEYOND THE OUTSIDE DIAMETER OF THE HEATER HEAD to permit removal of the head and shell for in-place maintenance.
  - d) Include all of the stop valves, check valves, steam traps, and other elements in the piping as shown in Figure 3, 4, 5, or 6, or as separately specified by AERCO. Note that the check valve shown at the Heater in the Condensate return line is furnished in the piping package assembly by AERCO.
  - e) The Condensate return piping MUST be arranged to permit Condensate to drain freely by gravity from the Heater Bottom Head. Failure to do so may result in improper Heater operation and/or in damage to the Heater Steam/Condensate system.

**(Continued)**

**Installing the Water Wizard Heater Instructions (Cont.)**

- f) All drain discharges – relief valve(s) in the Top Head of the Heater, outlet of the Water Solenoid Valve in the top head of the Heater, and Drain Valve in the Bottom Head of the Heater – should be piped directly to a convenient floor drain.
- 7) When a third P&T Relief Valve is furnished with the Heater (the first two furnished have been assembled in the top head of the Heater by AERCO), the third Valve is to be installed in the Heater hot water outlet piping, by the user, as illustrated in Figure 2.
- 8) Before making final piping connections to and from the Heater and Control Valve, blow out all piping thoroughly.
- 9) If an air-operated Control Valve is furnished in the Heater package, make the necessary supply air connection to the connector through the side of the Control Box (see Figure 20, Item 136). The supply air pressure must be maintained at 20 PSIG.
- 10) Connect 110 volt 60 Hz power supply wiring through the side of the Control Box to the electrical Junction Box (see Figure 20, Item 127).

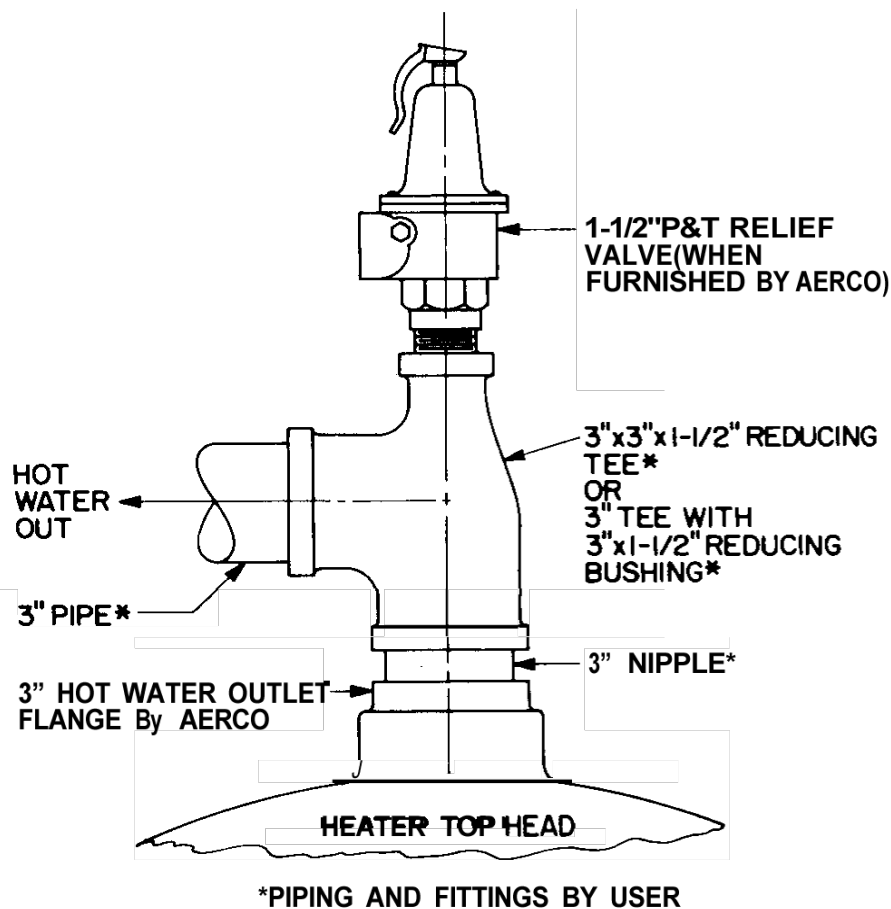

**Figure 2 – P&T Relief Valve Located in the Heater Hot Water Outlet Piping**

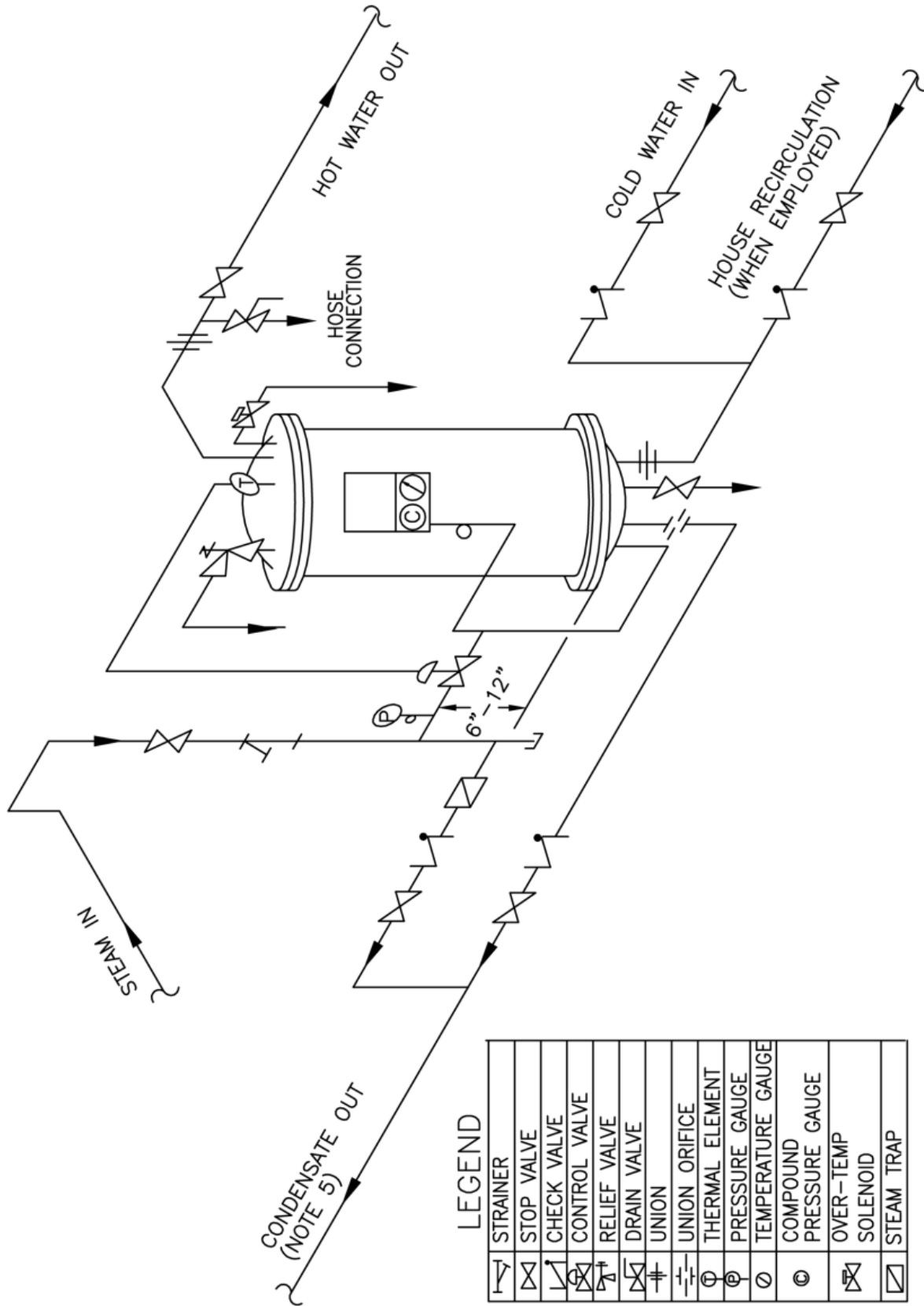

**Figure 3 – Piping Connections for a Single Heater**

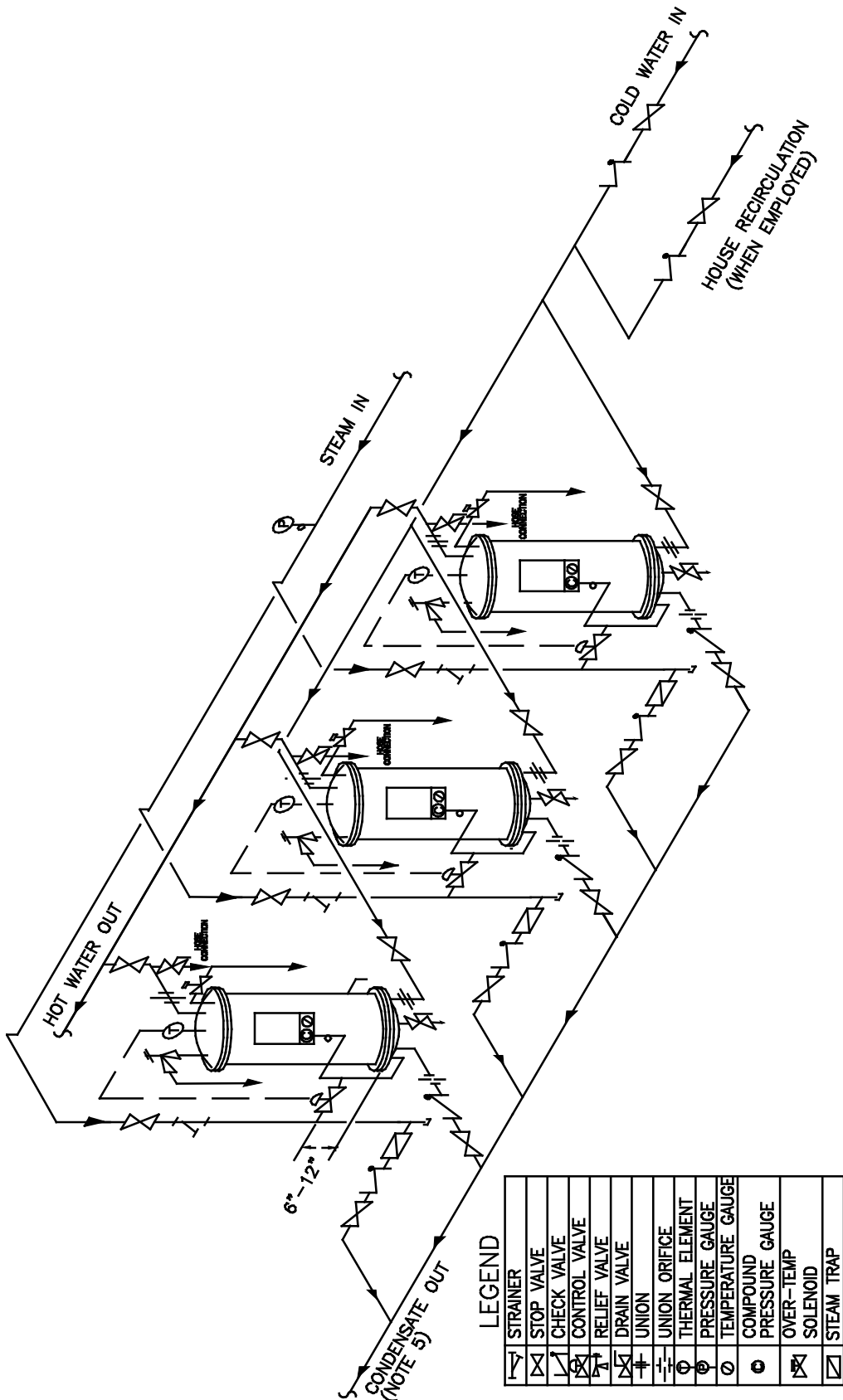

**LEGEND**

	STRAINER
	STOP VALVE
	CHECK VALVE
	CONTROL VALVE
	RELIEF VALVE
	DRAIN VALVE
	UNION
	UNION ORIFICE
	THERMAL ELEMENT
	PRESSURE GAUGE
	TEMPERATURE GAUGE
	COMPOUND PRESSURE GAUGE
	OVER-TEMP SOLENOID
	STEAM TRAP

**Figure 4 – Piping Connections for Parallel Heaters**

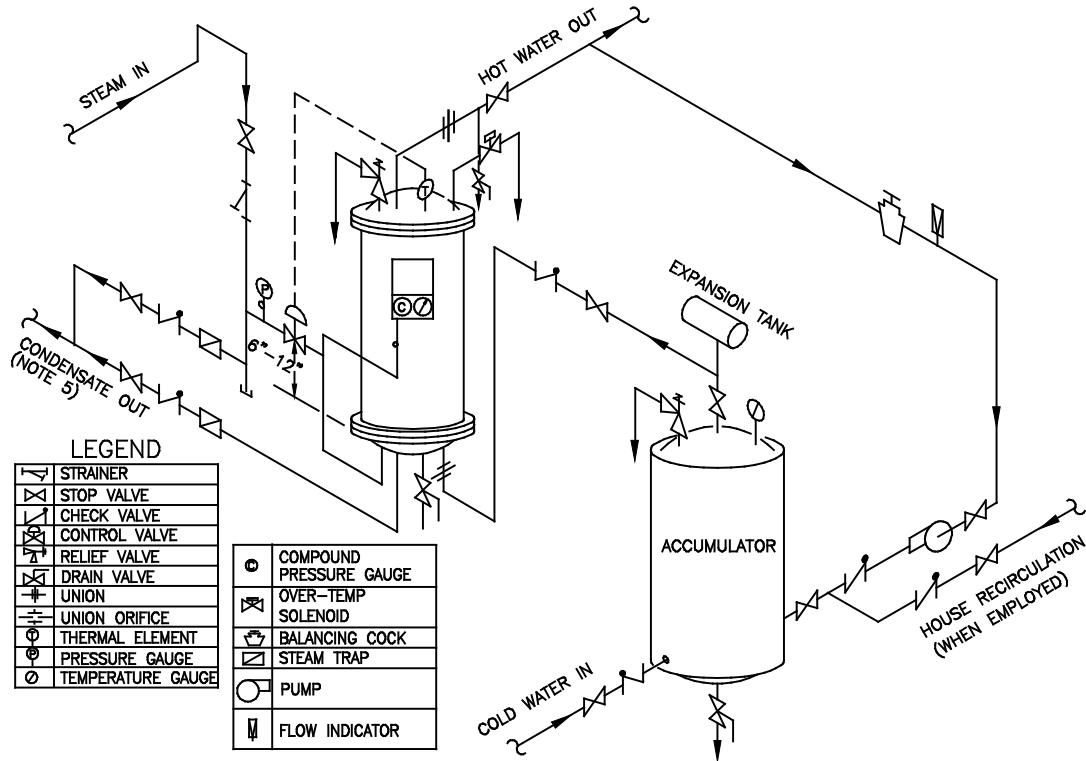

**Figure 5 – Piping Connections for a Single Heater used with an Accumulator**

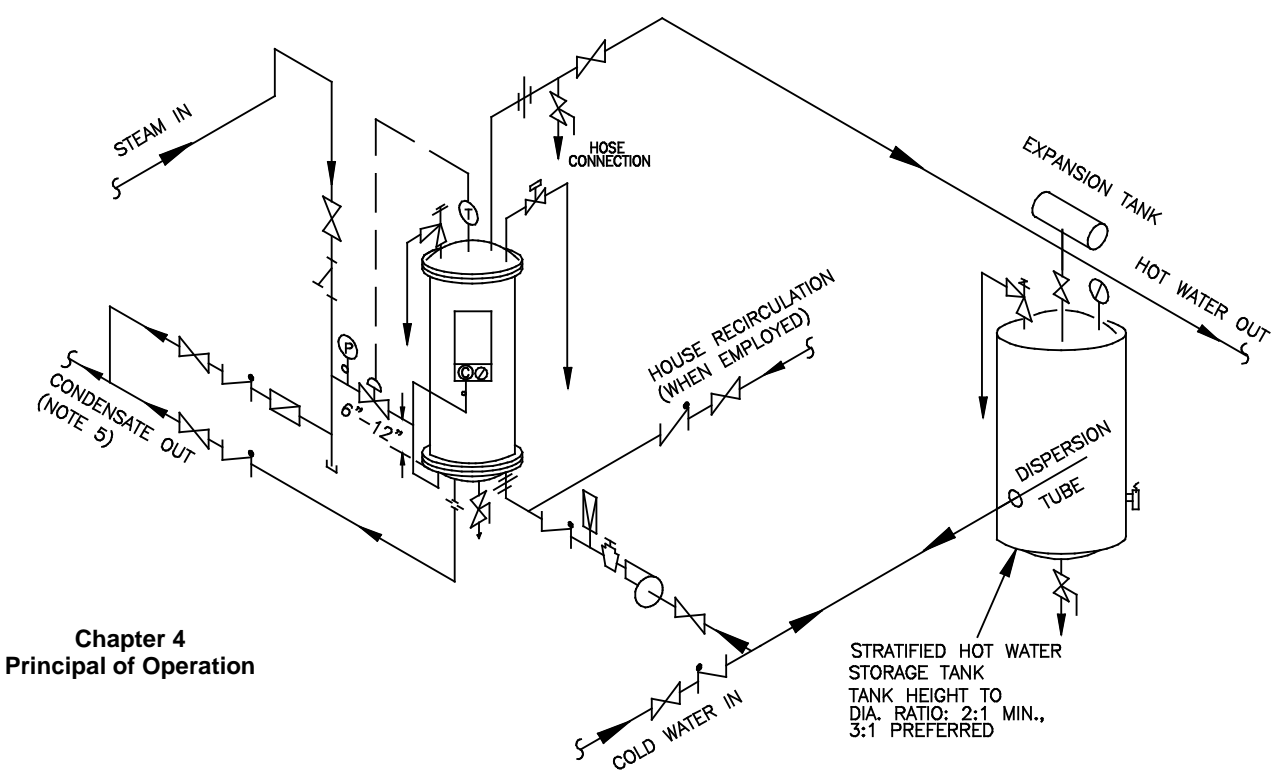

**Figure 6 – Piping Connections for a Single Heater used with a Stratified Storage Tank**



## **CHAPTER 4. PRINCIPLE OF OPERATION**

The AERCO Helitherm Heat Exchanger (Heater) consists of three parts (see Figure 7);

1. Shell with Top and Bottom Heads
2. Coils assembled to Steam Riser and Condensate Return
3. Integral Demand Anticipator Temperature Control Unit

Cold Water (or other liquid) enters the heater through the inlet connection and Orifice in the Bottom Head and strikes the Deflector. The Orifice serves to divert some Cold Water into the Shut Tube, whereas the Deflector disperses the incoming Cold Water evenly into the bottom of the Shell. The Cold Water in the Shell, then, flow upward among the Coils (heating surfaces) and, heated, is discharged through the Check Valve and Hot Water Outlet Connection in the Top Head.

Steam enters through the Control Valve and the Steam inlet connection in the Heater Bottom and is fed through the Steam Riser to the inlet of each Heat Exchanger Coil unit as shown in Figure 7. The Steam flows through these Coils units simultaneously in parallel and enters the Condensate Return as Condensate. The Condensate is fed through the Sub-Cooling Coil unit and leaves the Heater through the Condensate outlet connection in the Bottom Head of the Heater. The Sub-Cooling Coil unit is included in the assembly to provide the maximum possible condensing of the Steam, thus providing the greatest amount of heat transfer, the lowest Condensate outlet temperature, and the greatest reduction in energy loss from flash steam.

As noted above, the Cold Water being heated flows through the Heater from bottom to top. In addition, Heater Water, being of less density than Cold Water, migrates to the top of the Shell by convection. These actions result in the hottest Water always being at the top of the Heater – at the Heater outlet and at the How Water inlet to the Anticipator Temperature Sensing Tube – See Figure 7.

Hot Water from the top of the Heater Shell enters the open end of the Sensing Tube and Cold Water enters the Sensing Tube from the Shunt Tube at a rate proportional to the load (call for Hot Water) on the Heater. The mixture of Hot and Cold Water in the Sensing Tube creates an average temperature which necessarily will be cooler than the temperature of the Hot Water in the top of the Heater Shell.

### **4.1. HEAT EXCHANGER OPERATION WITH PNEUMATIC CONTROL**

The Temperature Sensing Element “reads” the average temperature of the Water in the Sensing Tube at any given moment and signals the Water in the Sensing Tube at any given moment and signals the Steam Control Valve to modulate between full open or closed as necessary to maintain the required Heater Hot Water outlet temperature. With no demand or load on the Heater, the Temperature Sensing Element reads only the temperature of the Water in the top of the Heater and at the Heater outlet. If that Water is at the required outlet temperature or above, the Sensing Element signals the Steam Control Valve to close.

However, the moment that there is a demand for Hot Water, Cold Water flows from the Shunt Tube to mix with the Hot Water I the Sensing Tube, cooling the Sensing Element so that it signals the Steam Control Valve to open. The need for Steam (heat) to the Coils is satisfied at once, the incoming Cold Water passing over the Coils is heated, and the Hot Water outlet temperature does not fall below that required.

The Demand Anticipator Temperature Control Unit, as its name implies, is constantly alert to lead conditions and changes, as well as to changes in the temperature of the incoming Cold Water, and provides FEED-FORWARD temperature control at all times.

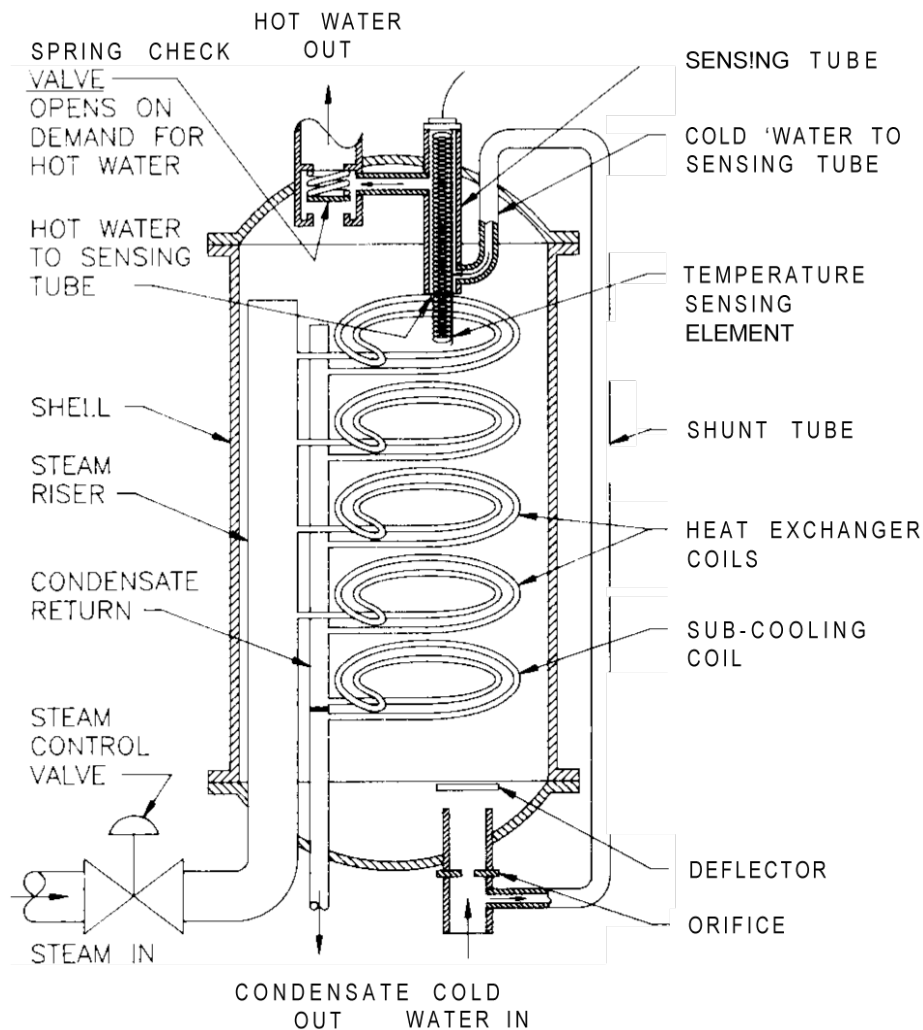

**Figure 7 – Schematic of AERCO Model B+II Water Heater showing Anticipator Temperature Control**

#### **4.2. HEAT EXCHANGER OPERATION WITH ELECTRONIC CONTROL SYSTEM (ECS)**

The Electronic Control System (ECS) available for the Water Wizard SW1B+II offers features and functions not described in this manual. Refer to the separate manual, AC-105, for detailed descriptions of the function and operation of the ECS and electronically operated valve, type CXT-E.

## CHAPTER 5. OPERATING PROCEDURES

### Water Wizard Operating Procedure Instructions

- 1) With the installation entirely completed, including:
  - 1) All piping connections have been made,
  - 2) All connecting piping has been cleaned (blown) out,
  - 3) All connections per Steps 8 and 9 under INSTALLATION have been made,

Open the stop valve in the Cold Water inlet line and hold the relief valve (or any one of the relief valves) in the Heater top head open to allow air to come out (otherwise an air pocket will be built up and the Heater will not fill). When water flows out of the relief valve, the Heater is full.
- 2) Temporarily set the Over-Temperature Limit System Temperature Switch in the Control Box (Figure 20, Item 126) to its high temperature limit.
- 3) If the Steam Control Valve furnished is air operated and there is a Temperature Controller in the Control Box (see Figure 8), set the Controller at the temperature desired to be held at the Heater Hot Water outlet.
- 4) Open the stop valve in the Hot Water outlet line. Open a Hot Water faucet or faucets in the building or process to insure a flow of water through the heater. For best results in adjusting the temperature control, a water flow of 10% to 25% of heater rating is desirable. Slowly open all stop valves in the Steam inlet and condensate outlet lines.
- 5) Slowly open all stop valves in the Steam inlet and Condensate outlet lines.
- 6) Follow the instructions furnished with the air-operated Temperature Controller and Control Valve or with self-contained Temperature Regulator Valve, and:
  - a) Introduce Steam to the Heater.
  - b) Adjust the air-operated Temperature Controller OR self-contained Temperature Regulator Valve until the Heater hot water outlet temperature is being held steady at the desired temperature. If the hot water outlet temperature is erratic, see **Step 7** below.
  - c) Close the hot water faucet or faucets opened in Step 4.
- 7) Open any stop valves in the building recirculation system if such is included in the Heater installation.
- 8) If the hot water outlet temperature is erratic especially during load changes:
  - a) Put a load on the Heater, by opening a hot water faucet or faucets in the building or process, as quickly as possible.
  - b) Adjust the Temperature Controller of Temperature Regulator to provide best response on load changes. See the instruction furnished with the Controller or Regulator.
- 9) Adjust the Over-Temperature Limit System Temperature Switch in the Control Box to its proper setting in accordance with the instructions furnished which cover the Over-Temperature Limit System – usually 15°F to 20°F higher than the desired hot water outlet temperature.

**(Continued)**

**Water Wizard Operating Procedure Instructions (Cont.)**

- 10) The Heater installation is now set for operation. No further operation procedure is necessary unless or until further temperature control adjustments may be required. If so, repeat Steps 4, 5, 6, 7, and, if necessary, Step 8.
- 11) To SHUT DOWN the System:
  - a) Close all stop valves in the Steam inlet and Condensate outlet lines.
  - b) In this order, close the stop valves in
    - i. the hot water outlet line,
    - ii. the recirculation line, if any, and
    - iii. the cold water inlet line (see Step 11c, which follows).
  - c) If the system includes an accumulator or stratified storage tank, DO NOT SHUT OFF THE COLD WATER UNTIL THE HEATER HAS COOLED DOWN. If the system is allowed to cool while the cold water is shut off, the Heater liner may collapse because of formation a vacuum in the Heater.
- 12) For DRAINING THE HEATER, see the instruction included under ROUTINE MAINTENANCE, Chapter 6, Section 6.1.
- 13) To START UP again, with the shell filled per Step 1 above, open the stop valves in the following order:
  - 1) stop valve in the Cold Water inlet line,
  - 2) any stop valve in the recirculation line, if any,
  - 3) stop valve in the Hot Water outlet line, and
  - 4) stop valves in the Steam inlet line and Condensate outlet lines.
- 14) After each startup, check the temperature control. If necessary, make adjustments per Steps 4 through 9.

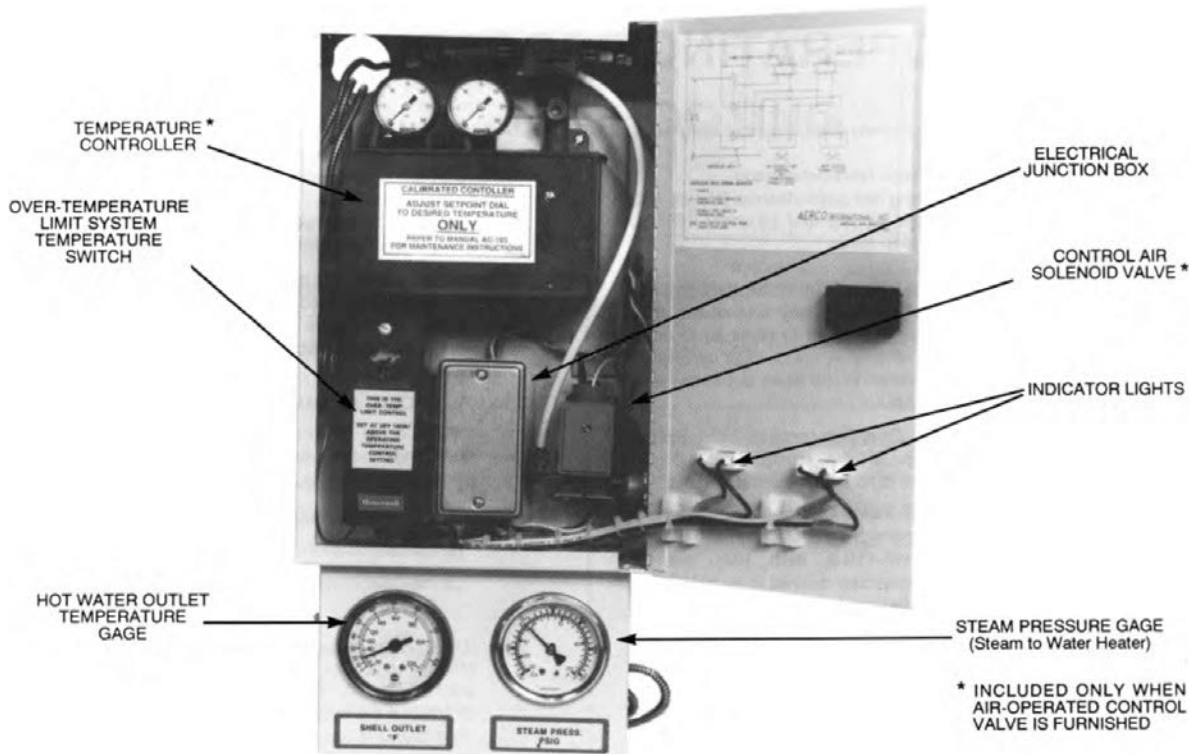

**Figure 8 – Model B+II Heater Control Box**

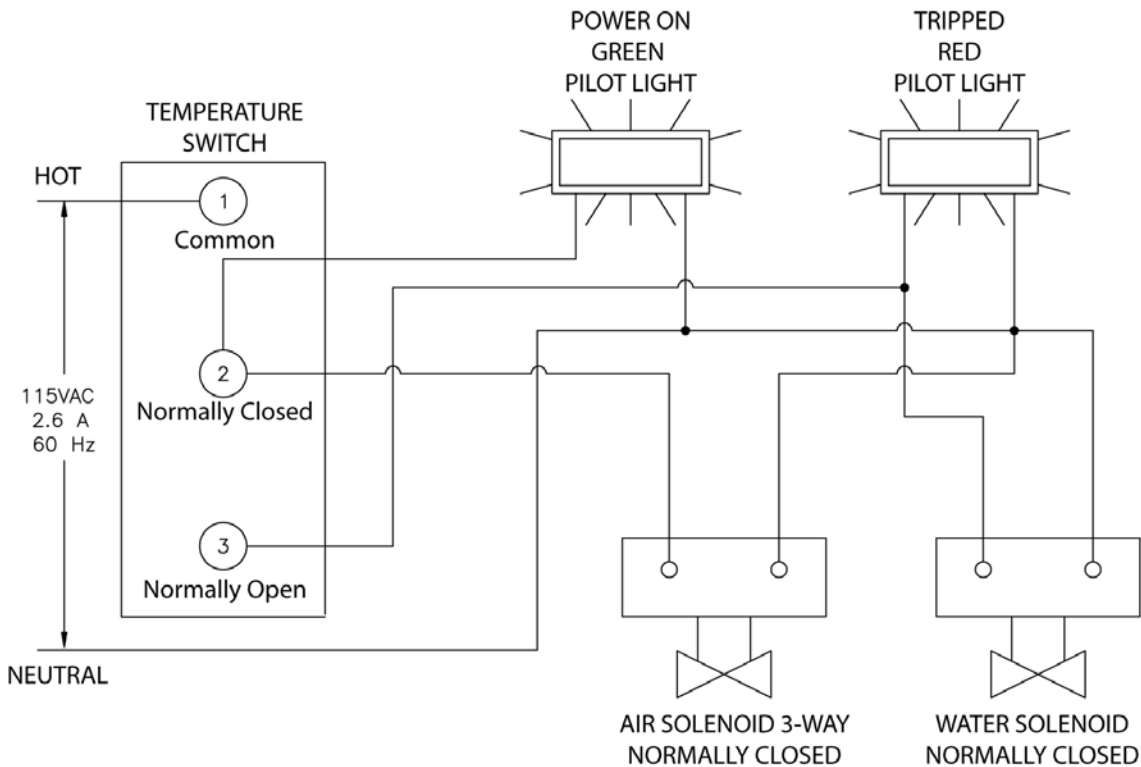

**Figure 9 – Over-Temperature Limit System Wiring Diagram**

## **CHAPTER 6. ROUTINE MAINTENANCE**

### **6.1. DRAINING THE HEATER**

The constant flexure of the Heater coils under varying load conditions automatically provides a de-scaling action and prevents a buildup of brittle scale. A periodic blowdown (draining) is required to remove accumulated solids.

After the first 3 months of initial operation, drain the Heater as follows:

- (1)** Close all stop valves in the Steam inlet and Condensate outlet lines.
- (2)** In this order, close the stop valves in
  - a) the hot water outlet line,
  - b) the recirculation line, if any, and
  - c) the cold water inlet line.
- (3)** Carefully open the relief valve (or one of the relief valves) in the Heater top head to relieve pressure in the Heater shell. If water continues to flow from the relief valve one of the stop valves either leaks or is not shut off tight. This must be remedied until there is no more flow through the relief valve.
- (4)** With the relief valve being held open, (to prevent creating a vacuum in the shell) open the drain valve and drain the Heater completely.
- (5)** To refill the Heater and place it back into operation, close the drain valve and proceed through Steps 1, 12, and 13 under OPERATING PROCEDURES, Chapter 5.

### **6.2. CHECKING THE DRAINED WATER**

The constant flexure of the Heater coils under varying load conditions automatically provides a de-scaling action and prevents a buildup of brittle scale. A periodic blowdown (draining) is required to remove accumulated solids.

After the first 3 months of initial operation, drain the Heater as outlined below. Examine the water being drained.

- (a) If the amount of solids appears to be heavy, set a schedule to drain the Heater every 3 months.
- (b) If the amount of solids appears to be light, set a schedule to drain the Heater every 6 months.
- (c) Even if the amount of solids appears to be very light, set a schedule to drain the Heater at least once each year.
- (d) Also see TROUBLESHOOTING, Chapter 7 and CORRECTIVE MAINTENANCE, Chapter 8. If de-scaling by thermal shock is required, schedule that procedure in your ROUTINE MAINTENANCE, Chapter 9.

### **6.3. CHECKING THE TEMPERATURE CONTROL**

Check the temperature control at least once every 3 months. Make any necessary adjustments per Steps 4 through 8 under OPERATING PROCEDURES, Chapter 5.

**CHAPTER 7. TROUBLESHOOTING**

SYMPTOM	PROBABLE CAUSE & REMEDY “CORRECTIVE MAINTENANCE” ITEM NO.
Heater does not maintain required temperature at rated capacity.	1, 2, 6, 12, 14, 17, 18, 19
Heater overheats.	1, 5, 6, 8, 11, 13, 14
Hot Water outlet temperature fluctuates widely.	2, 6, 11-14, 17, 19
Insufficient Water through or from Heater.	3, 15
Excess or insufficient Condensate being returned from Heater.	6, 7
Steam being discharged into Condensate drain,	18, 19
Pressure/Temperature Relief Valve pops.	4-6, 8-11, 13, 14, 16
Heater shuts down below, at, or too near above required Hot Water temperature.	16
Loud banging in heater or in Steam or Condensate piping (not to be confused with normal clicking noise).	6, 7, 9, 10

## CHAPTER 8. CORRECTIVE MAINTENANCE

Refer to table in **TROUBLESHOOTING**, Chapter 7 for a description of problematic symptoms.

The following are probable causes and remedies for improper function of the Heater.

1. **The temperature gage or steam pressure gage, or the Steam supply pressure gage ahead of the Control Valve, may be wrong.** Check each with a gage which is known to be correct.
2. **Steam pressure is too low. Check the steam supply pressure gage ahead of the Control Valve.** If the reading is low, adjust the steam supply pressure to that which is required. If there is a restriction in the steam supply line, the gage reading will drop excessively when the Heater calls for full steam even though the pressure appears to be normal when the load is light. If the steam supply pressure is correct, the steam gage (below the Control Box) reading should reach design pressure for steam in the coils as the Heater temperature drops. If it does not, check the operation of the Control Valve.
3. **Cold Water pressure is low.** Check and correct, if necessary, the Water pressure to the Heater.
4. **Static pressure of the Cold Water is too high.** Make the necessary corrections to bring the Water pressure below that for which the Relief Valve(s) is set.
5. **Water to be heated is preheated too hot.** Reduce the preheating to a temperature at least 10°F under the desired Heater hot water outlet temperature.
6. **Condensate return piping has not been installed so that the Condensate drains freely by gravity and/or the Condensate check valve leaks or has failed.** If necessary, rearrange the Condensate return piping per Step 6e under INSTALLATION, Chapter 3. Inspect the check valve and replace it if it is leaking or has failed. Also, check to make sure there is no restriction in the Condensate drain line.
7. **Steam supply line is not properly trapped.** Install trap as indicated in Figure 2, 3, 4, or 5.
8. **Leaking stop valve in bypass line, if any, around the Steam Control Valve.** Maintain the stop valve to shut tight.
9. **Lack of expansion tank in the hot water system.** Install an expansion tank in the outlet hot water line close to the heater.
10. **Insufficient shock absorbers.** Insert shock absorbers (water hammer arresters) in both the cold and hot water systems as needed to eliminate shock waves.
11. **The Steam Control Valve does not close.** Check the instructions covering the Valve.
12. **The Steam Control Valve does not open.** Check the instructions covering the Valve.
13. **The temperature control thermal element (connected to the air-operated Temperature Controller or the self-contained Control Valve and located in the Heater top head) has failed.** Refer to the instructions covering the Temperature Controller or Control Valve.
14. **The Anticipator Unit system is not operating properly.** Check to make sure that the temperature sensing element has not failed (see Item 13, above), that the shunt tube (item



87 in Figures 17 and 18) has not become clogged, and that the check valve at the hot eater outlet is working properly (see Item 15, below). Make any necessary corrections.

- 15. The Anticipator Check Valves at the Heater hot water outlet is not working properly.** Disassemble and inspect the Check Valve, clean the Valve, and repair or replace any parts as necessary per Steps 1 through 5 under DISASSEMBLY, Chapter 10, Section 10.4.1.
- 16. The Over-Temperature Limit System is out of adjustment of some component of the system has failed.** Check out the systems setting per Step 8 under OPERATING PROCEDURES, Chapter 5. Inspect and repair or replace each component as necessary.
- 17. There is a leak in the Heater coil(s), steam riser, or condensate return, causing water from the shell to leak into the heating coil system, or steam or condensate from the coil system to the shell.** To verify such a leak, shut off the steam supply and break a connection in the Condensate Line – CAREFULLY to avoid being burned. Condensate will drain from the coil system initially, but the flow should stop after a minute or two. If the flow continues, water is leaking from the pressurized shell side to the tube side of the Heater. Disassemble, inspect, repair (if possible), replace, and reassemble the Heater as outlined below under DISASSEMBLY, Chapter 10, and REASSEMBLY, Chapter 12.
- 18. The Heater coils are scaled up.** De-scale the Heater by thermal shock in the manner outlined below under DESCALING BY THERMAL SHOCK METHOD, Chapter 9.
- 19. The Heater is being utilized at a rate higher than its design capacity.** Contact the nearest AERCO Representative for advice in remedying this problem.

## **CHAPTER 9. DE-SCALING BY THERMAL SHOCK METHOD**

Where, under certain conditions of continuous steady usage, the Cold Water is so hard or alkaline that normal flexure of the Heater coils (see Routine Maintenance) and routine blow down (draining the Heater shell) will not remove scale buildup on the coils, the heating surfaces (coils) may be thermally shocked, without damage to any part of the Heater, to dislodge scale solids.

### **De-Scaling by Thermal Shock Instructions**

- 1)** Drain the Heater per steps 1 through 4, Chapter 6, ROUTINE MAINTENANCE, Chapter 6. However, instead of holding the relief valve open in step 4, remove the relief valve, shown as Item 73(A) in Figure 17 or 18 from the Heater top head.
- 2)** Open the Heater drain valve. Leave the drain valve open until step 8 below.
- 3)** Connect a source of cold water (for example, a hose from a cold water faucet) to the open relief valve connection.
- 4)** Open all shutoff valves in the Steam inlet line and the Condensate outlet line to allow Steam to the Heater. After about 30 seconds, or until Steam is blowing out of the Condensate drain line, close the stop valve in the Condensate outlet line. Leave the Steam inlet line open for about two minutes longer, and then close all Steam inlet stop valves.
- 5)** Inject a flow of cold water through the relief valve connection for about two minutes. Then shut off the cold water flow and open the Condensate line stop valve to drain off all Condensate.
- 6)** Repeat steps 4 and 5 several times until the water coming from the Heater drain appears to be relatively free of solids.
- 7)** Remove the cold water source from the relief valve connection. Open the stop valve in the main Cold Water inlet line and allow a complete flushing of the Heater shell.
- 8)** After the Heater shell has been completely drained, close the Heater drain valve, and place the Heater back into operation per steps 1, 12, and 13 under OPERATING PROCEDURES, Chapter 5.
- 9)** If Cold Water conditions are so severe that thermal shocking does not remove scale deposits, consult the nearest AERCO Representative for advice.

---

## **CHAPTER 10. MAINTENANCE DISASSEMBLY**

### **10.1. TOOLS AND EQUIPMENT**

The following common and special tools and equipment are required to perform the instructions contained in this chapter:

#### **10.1.1. Common Tools and Equipment**

- Combination Wrenches: 7/16", 5/8", 13/16", 1-1/16", 1-1/8"
- Pipe Wrenches: 12" and 24"
- Chain Hoist
- Voltmeter:
- Brass Wire Brush
- Needle-Nose Pliers
- Gasket Removal Tool
- Carpenter's Square
- Teflon Tape
- Orange Citric Cleaner
- Black Marker

#### **10.1.2. SPECIAL TOOLS AND EQUIPMENT REQUIRED:**

- Hydrostatic Pressure Pump: Range= Up to 235 psig
- Torque Wrench, 75 ft.-lbs. With 1-1/4", 1-5/16" & 1-1/2" Open-End Spanners (1-1/4" Open-End Spanner required for "A" Heater Only)
- Coil Retaining Tool (Figure 1)
- Coil Spacing Tool (Figure 1)
- Short-Length Wrenches: 1-1 /4", 1-5/16", 1-1/2"  
(Overall wrench lengths should be approx. 6 inches or less)

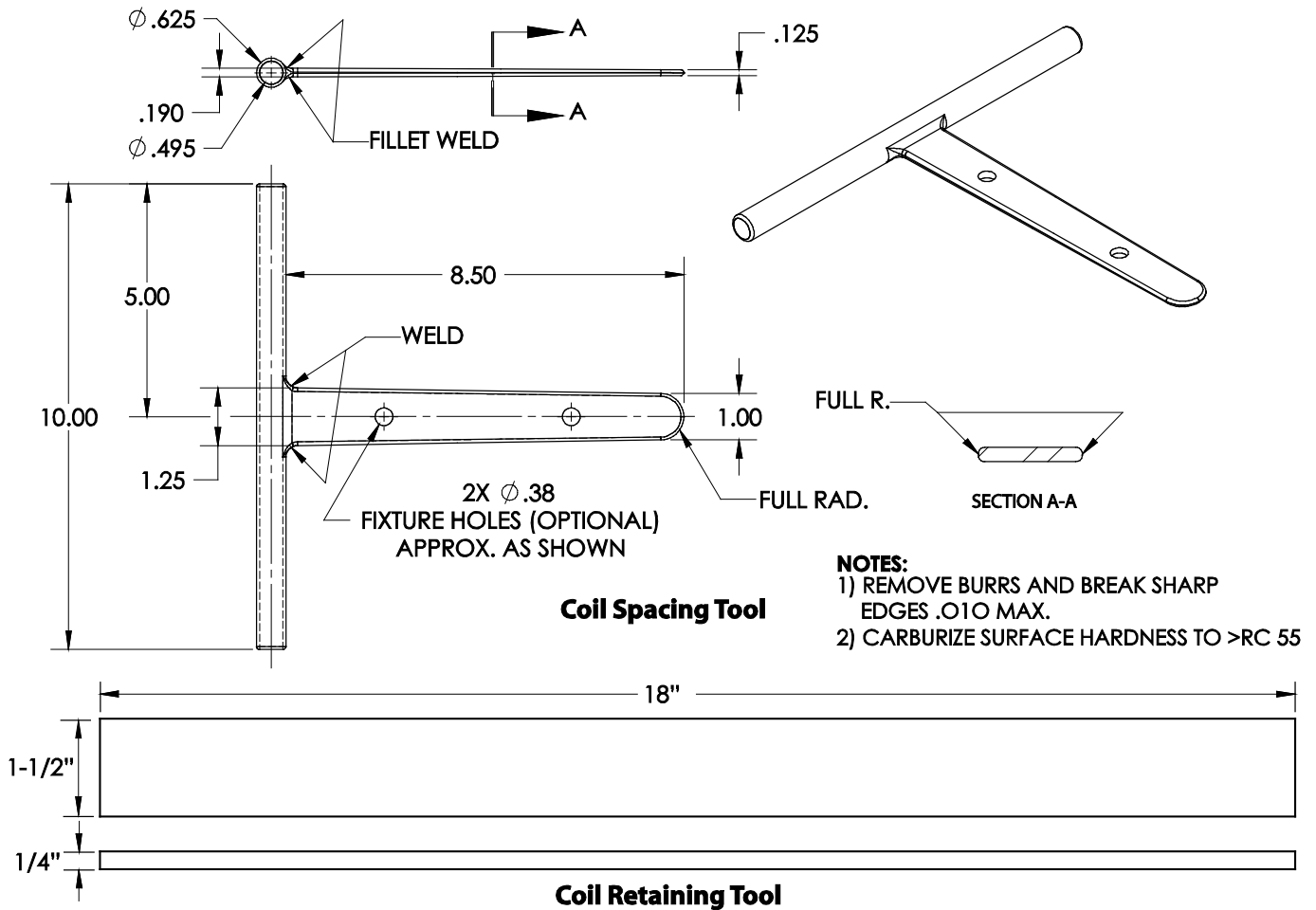

**Figure 10: Tool Fabrication Details: Coil Spacing and Retaining Tools**  
 Recommended Material: 1018 steel

**NOTE:**

The procedures in the following paragraphs are arranged to isolate, disconnect and disassemble the unit to the extent necessary to repair or replace defective items. These procedures should be performed in the order specified to minimize repair time.

**10.2. ISOLATING THE HEATER**

To isolate the Heater from all facility energy sources (steam, water, electrical, etc.), proceed as follows:

**Isolating the Heater Instructions**

- 1) Disconnect and Lock-Out/Tag-Out external AC power supplied to the Control Box and any other devices connected to the Heater.
- 2) Using a voltmeter, check to ensure that all incoming voltage readings are zero Before continuing.
- 3) If the Heater is equipped with a Pneumatic Steam Valve, close the valve supplying air inlet pressure to the Pneumatic Controller.
- 4) Close all stop valves in the Steam Inlet and Condensate Outlet lines
- 5) On the water-side, close the stop valves in the following order:
  - Hot water outlet line
  - Recirculation line
  - Cold water inlet line
- 6) Carefully open the Relief Valve located on the Top Head to relieve pressure in the Heater Shell. Water should stop flowing from the valve within one minute. If water continues to flow from the Relief Valve, one of the water stop valves is not securely closed.
- 7) While holding the Relief Valve open to prevent creating a vacuum in the Shell, open the Drain Valve in the Bottom Head on the Heater. Completely drain the potable water from the Heater.

### **10.3. DISCONNECTING THE HEATER FROM THE FACILITY**

To disconnect the Heater from the facility piping and wiring connections, proceed as follows:

#### **Disconnecting the Heater from the Facility Instructions**

- 1)** First, check the ceiling height to determine if the Heater Shell and Top Head can be hoisted up with the Heater remaining in position.
- 2)** If there is sufficient ceiling clearance to permit safe elevation of the Shell assembly, skip to step 8. If there is insufficient clearance, proceed to step 3 to remove the Heater from its current location.
- 3)** Using a 5/8" combination wrench, remove the Steam Pressure Line from the Steam Line and Pressure Gauge.
- 4)** Disconnect the Steam line from the Valve and Bottom Head.
- 5)** Disconnect the water inlet from the Bottom Head.
- 6)** Disconnect the drain line from the Bottom Head.
- 7)** Disconnect the Condensate Drain piping from the Bottom Head.
- 8)** Disconnect all electrical wires to the Control Box. Also, disconnect all wiring between the Control Box and any external Solenoid Valve(s).
- 9)** Using a 5/8" combination wrench, remove the Steam Pressure line from the Steam Line and Pressure Gauge, if it was not performed in step 3.
- 10)** Remove the water outlet piping from the Top Head.
- 11)** Remove the pipe drain(s) from the Pressure Relief Valve(s).
- 12)** Disconnect the pipe drain from the Water Solenoid Relief Valve.
- 13)** Using a 13/16" combination wrench, disconnect the compression fittings on the Cold Water Feed Tube from the Top Head and Bottom Head.
- 14)** If controlled by a Pneumatic Valve, disconnect the incoming air supply to the Control Box and Steam Valve.
- 15)** If controlled by a Self-contained Valve, remove the thermal well from the Top Head that is attached to the Valve.

**10.4. ANTICIPATOR CHECK VALVE DISASSEMBLY**

To disassemble the Anticipator Check Valve, proceed as follows:

**10.4.1. Special Tools Required**

- Torque wrench for 5/8" nuts.
- A block and tackle or ratchet hoist is recommended for lifting off the Heater top head and shell, or for lifting and moving the Heater.

**Anticipator Check Valve Disassembly Instructions**

- 1) Shut down the Heater in accordance with Step 10 under OPERATING PROCEDURES. Manually (and carefully) open a relief valve to relieve any pressure in the Heater shell.

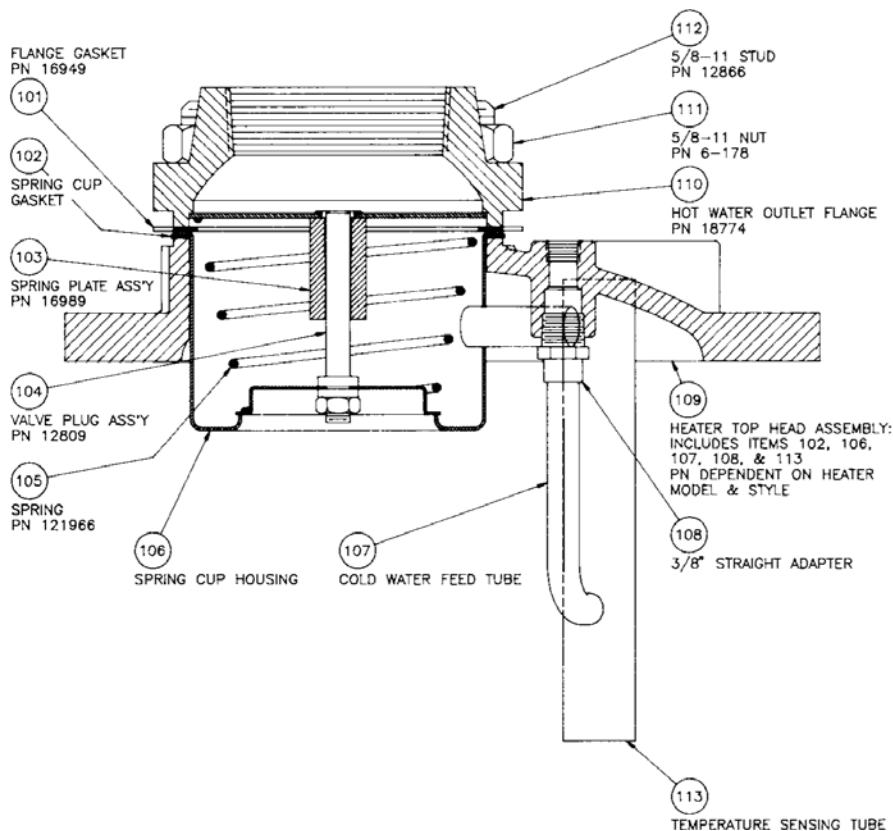

**Figure 11 – Model B+II Heater Control Box**

- 2) Disconnect the union in the Hot water outlet piping (the one located beyond the outside diameter of the Heater top head). Then remove the Nuts (51) and the Outlet Flange (31) and outlet piping.
- 3) Separately, lift the Spring Plate Assembly (33), the Gasket (32), the Spring (34), the Washer (35), and the Valve Plug (35).
- 4) Clean all parts and gasket surfaces thoroughly, and repair or replace any part necessary to make the Check Valve operate properly (open on water flow through the Heater).

### 10.5. PREPARING TO REMOVE THE HEATER SHELL

Note that all part item numbers are given in parentheses ( ) in the instructions below refer to those shown in Figures 14, 15, 16, 17, or 18.

Also, Note that it is not necessary to disassemble or remove the Check valve Assembly (see above) in order to remove the Heater Shell.

#### Preparation for Heater Shell Removal Instructions

1. Shut down and drain the Heater in accordance with Steps 1 through 4 in ROUTINE MAINTENANCE, Chapter 6.
2. If a self-contained Control Valve is being used, remove the Valve's Temperature Control Thermal Element from the Thermal Well Bushing (62) in the Heater Top Head. Be careful not to damage the Element or its capillary.
3. Disconnect ALL external piping from the Heater Top Head, including that to the Relief Valve(s) (67) and the Water Solenoid Valve (73). Disconnect the Hot Water outlet piping at the union or flange located beyond the outside diameter of the Heater Top Head.
4. Disconnect the power supply wiring to the Control Box and all wiring between the Control Box and any outside Solenoid Valve(s).
5. Disconnect the Pressure Gage pressure line Compression Fitting (60).
6. Disconnect the Compression Fitting (59), located at the bottom of the Shunt Tubing (69) from the Heater Bottom Head.

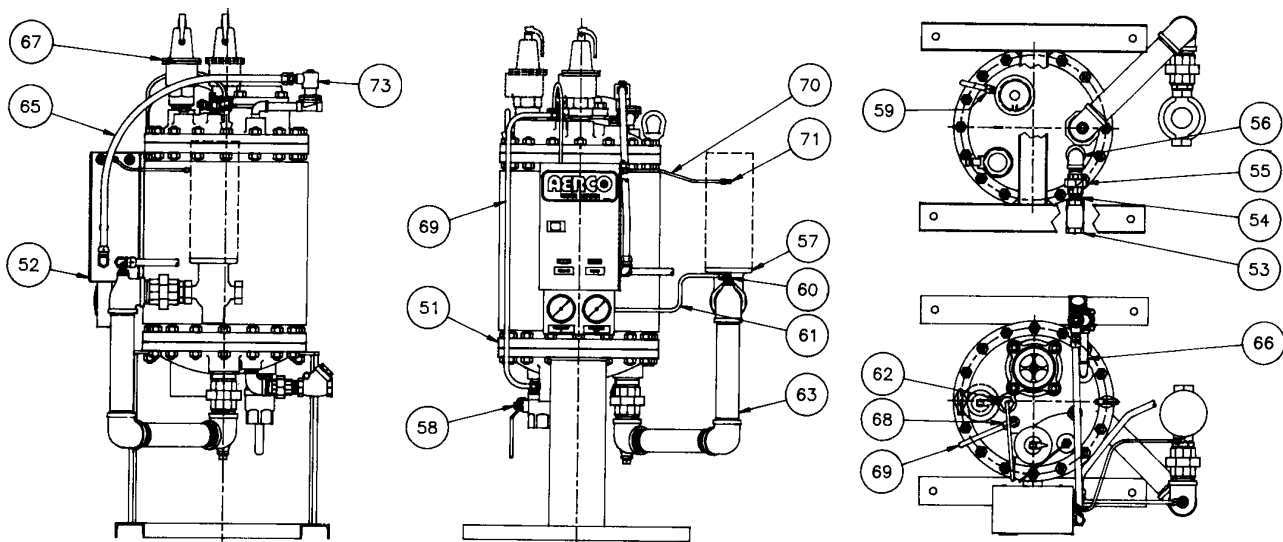

Figure 12: Part Reference for Heater Shell Removal



**10.6. REMOVING THE HEATER SHELL**

Remove the Heater Shell as follows:

**Heater Shell Removal Instructions**

- 1) Using a black marker, mark the edge of the Heater Bottom Head flange and Shell flange in order to indicate their correct relative positions upon reassemble. The Top Head can remain attached to the Shell.
- 2) Using the 1-1/16" combination wrench, unbolt the sixteen studs and nuts around the bottom ring of the Shell. The two nuts located in-line with the mounting skid legs are to be removed with the stud left in place.
- 3) Attach a chain hoist to the two lifting lugs on the Top Head. Lift the Shell up to clear the internal coil bundle.
- 4) Using a light source, visually inspect the inside of the Heater Shell for evidence of damage to the Copper Shell Liner. If any area of the Copper Liner is damaged, replace the Shell down on the Bottom Head and contact your local AERCO Representative to process return of the Heater to AERCO for repair.
- 5) Move the heat exchanger bundle a few feet to the side so that the Shell can be lowered to the floor. Set the Shell on clean surface. Use care to avoid damaging the bottom edge of the Copper Shell Liner.

**10.7. REMOVING COILS AND RISERS**

The Coil Assemblies, Riser and Condensate Return are removed as follows:

**Removal of Coils and Risers Instructions**

- 1) Using the proper size open-end wrench, loosen the two Union Nuts securing the Coils to the Steam Riser and Condensate Return.
- 2) Using a pipe wrench, remove the Steam Riser and Condensate Return from the Bottom Head.

## CHAPTER 11. CLEANING AND INSPECTION

Prior to reassembling Heater components, the Bottom Head, Steam Riser, Condensate Return and Coils must be cleaned, inspected and prepared as described in the following paragraphs:

### 11.1 PREPARATION OF BOTTOM HEAD

The Bottom Head of the Heater must be cleaned, inspected and prepared for reassembly as follows:

#### Preparation of Bottom Head Instructions

- 1) Clean off all debris from the topside of the Bottom Head.
- 2) Visually inspect the internal pipe threads where the Risers are connected. The overall depth of threads should measure, (1-1/8" for 2" NPT and 1" for 1" NPT)
- 3) If the threads are less than the required depth, use the appropriate 1" or 2" NPT tap to clean out the threads.
- 4) Using the gasket removal tool, remove the Shell Gasket from the Bottom Head. Use care to avoid creating scratches or indents in the Bottom Head casting's gasket surface area. Any linear scratches can potentially create a leak.
- 5) Apply pipe dope to the internal NPT threads in the Bottom Head.

### 11.2 PREPARATION OF RISER AND RETURN

The Riser and Return piping of the Heater must be cleaned, inspected and prepared for reassembly as follows:

#### Preparation of Riser and Return Instructions

- 1) Visually inspect all Steam Riser and Condensate Return Spuds, (Figure 2) threads and sealing surfaces for damage, scratches, braze material and cleaning deposits. If defects are found with the Spud threads or sealing surfaces, contact your AERCO Representative for instruction to return the defective Riser.
- 2) Using a brass wire brush, clean the threads of the Spuds. Use care to avoid scratching the sealing surfaces of the Spuds. Scratches can cause a leak path under the Coil Gasket. After brush cleaning, wipe with a clean lint-free cloth.
- 3) Using a brass wire brush, clean the pipe threads on the Riser. After cleaning, wipe with a clean lint-free cloth.
- 4) Wrap two layers of Teflon tape around the Riser NPT threads.



**The use of Teflon tape or any lubricant on the threads of the spuds is prohibited and may void the warranty.**

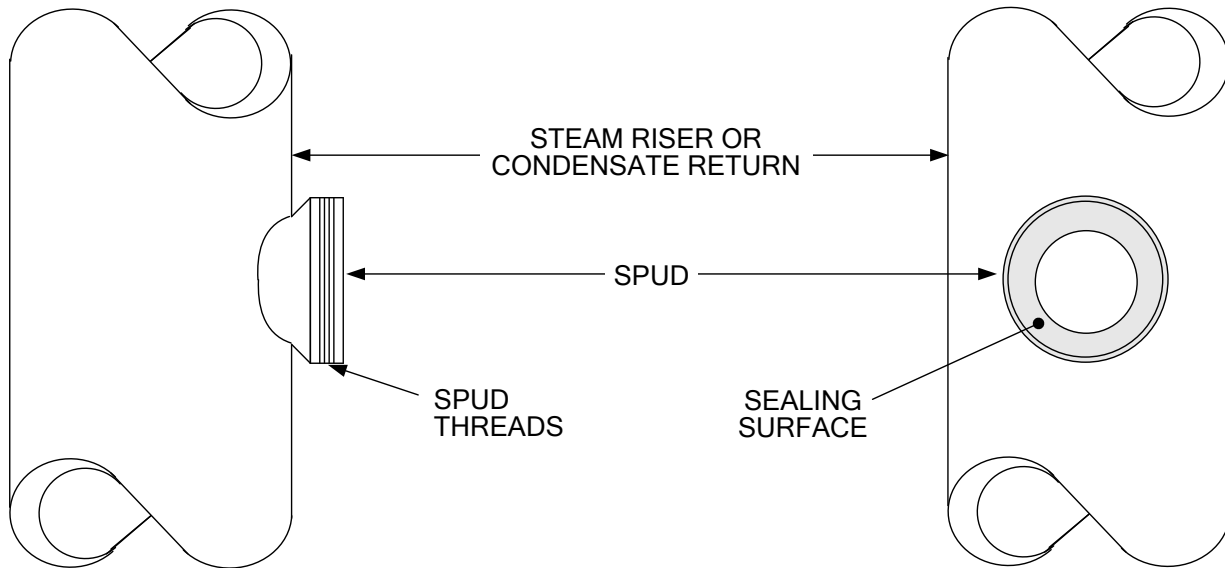

**Figure 13: Preparation of Riser/Return Spuds**

### 11.3 PREPARATION OF COIL ASSEMBLIES

The Coil Assemblies of the Heater must be cleaned, inspected and prepared for reassembly as follows:

#### **Preparation of Coil Assemblies Instructions**

- 1) Visually inspect all Tail Piece sealing surfaces for cleanliness and evidence of damage. (Figure 14).
- 2) Pull the Union Nut forward against the seating surface of the Tail Piece and rotate the Union Nut several turns to check for any obstructions around the perimeter of the seating surface. (Figure 14).
- 3) Contact your local AERCO Representative for replacement of the Coil if obstructions prohibit the rotation of the Union Nut.
- 4) Using a brass wire brush, clean the internal threads of the Union Nut.
- 5) Using a citric orange cleaner, spray the area between the Union Nut and Tail Piece. While pulling the Union Nut forward against the seating surface of the Tail Piece, rotate the Nut to remove any residue that can cause unneeded friction between the two surfaces.
- 6) Form the Coil by creating a 1/8" minimum gap between the individual tubes and a 1/8" to 1/4" gap between the four layers of tubes as shown in Figure 15. Maintain a flat surface on the top and bottom tube surface of the Coil.

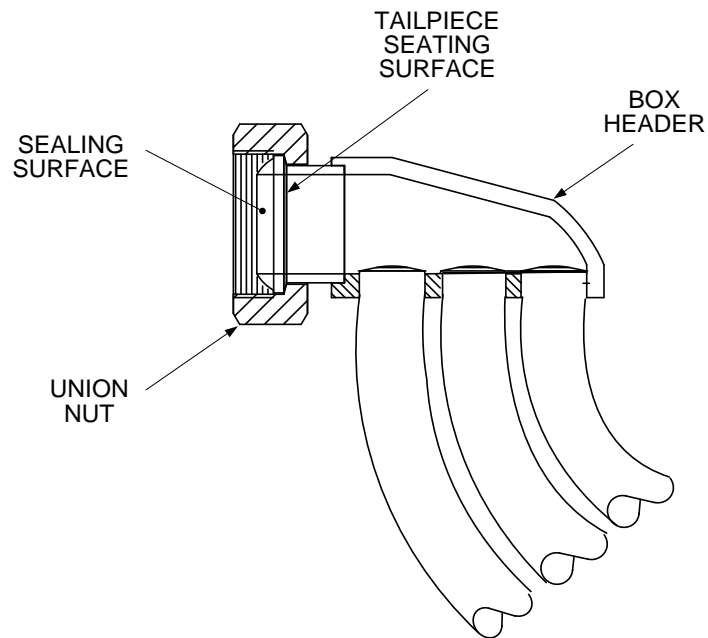
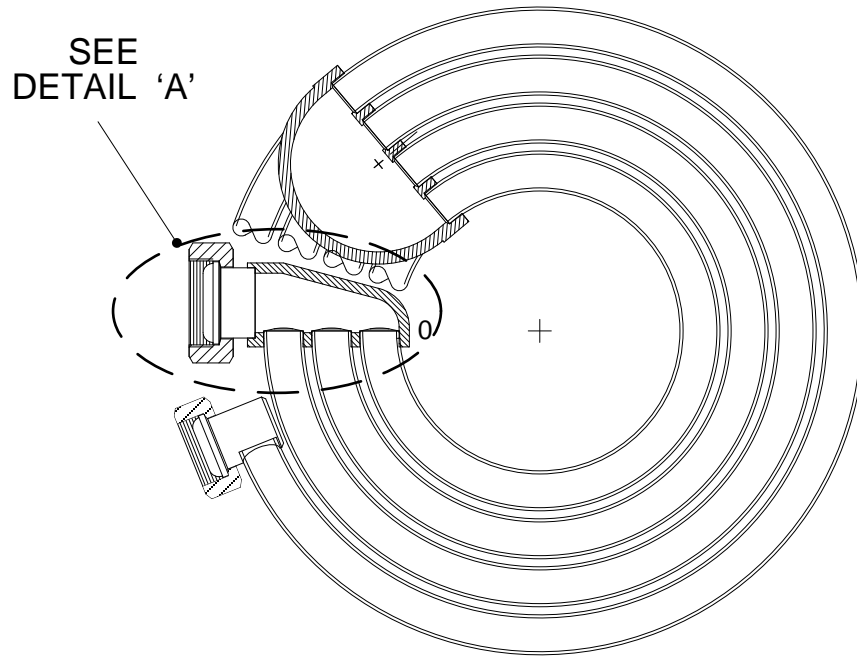

**DETAIL 'A'**

**Figure 14: Coil Assembly Preparation**

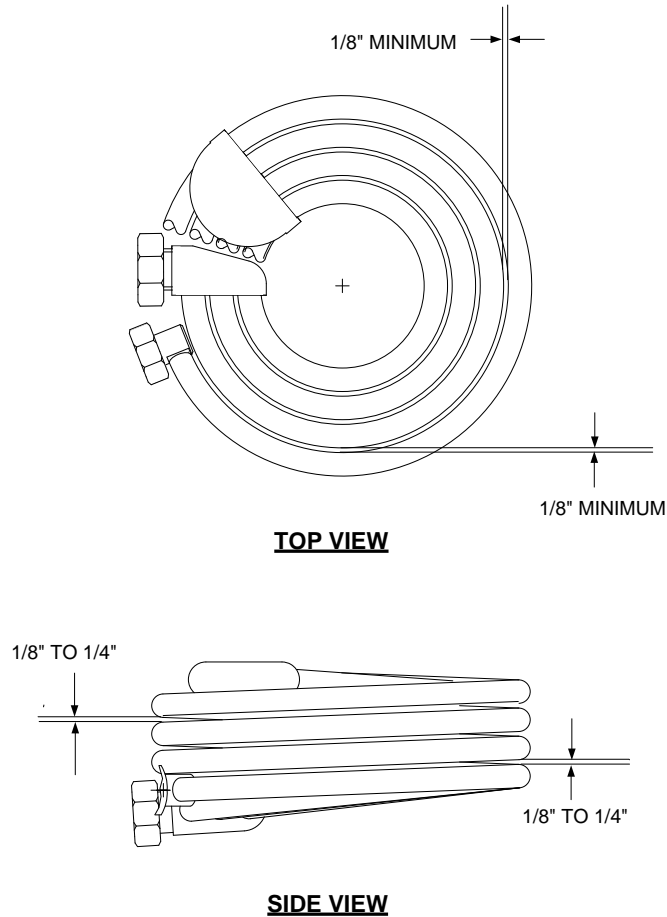

**Figure 15: Coil Assembly Spacing**

## 11.4 PREPARATION OF COIL GASKETS

Two 6-tab gaskets are provided with each replacement Coil Assembly. Proceed as follows:

### Preparation of Coil Gaskets

- 1) Form the Gasket into a round shape
- 2) Using Needle-Nose Pliers, form the 6 tabs on each Coil Gasket by bending each tab outward 2 to 3 degrees as shown in Figure 16. This will secure the Gasket into the Spud's inside diameter.

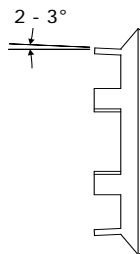

**Figure 16: Coil Gasket Preparation**

## CHAPTER 12. MAINTENANCE REASSEMBLY

### 12.1 REASSEMBLY OF RISERS, SUB-COOLING COIL, AND STEAM COILS

Following preparation of all Heater components as described in ROUTINE MAINTENANCE, Chapter 6, the Heater is ready for reassembly as described in the following instructions.

#### 12.1.1. Riser Installation

Install the Risers as follows:

#### Riser Installation Instructions

- 1) Thread the Steam Riser into the Bottom Head.
- 2) Tighten the Riser until the center of the Spud is visually lined up to the cast notch on the Bottom Head.
- 3) Thread the Condensate Riser into the Bottom Head.
- 4) Tighten the Riser until the center of the Spud is visually lined up to the cast notch on the Bottom Head.
- 5) If this is a B+ II Water Wizard, thread the Sub-Cooling Coil onto the Condensate Riser, hand tight (ref. paragraph 7.2). If this is not a B+ II Wizard Bundle assembly, proceed to step 9.
- 6) Measure the distance between the outside diameter of the Coil to the threaded stud protruding through the Bottom Head on both sides of the Coil (Figure 6).
- 7) Position the Condensate Riser to create an equal distance between both measurements shown in Figure 6.
- 8) Remove the Sub-Cooling Coil.
- 9) Thread a Steam Coil onto the Steam Riser, hand tight.
- 10) Position the Steam Riser so that the Condensate Tailpiece is aligned with the Spud on the Condensate Riser.
- 11) Remove the Steam Coil.
- 12) Insert the properly formed Coil Gaskets into each Spud. Ensure that the Coil Gasket snaps into the Spud (Fig. 7).
- 13) If the Coil Gasket is loose in the Spud, remove it and reform the six tabs to create a positive connection into the Spud.

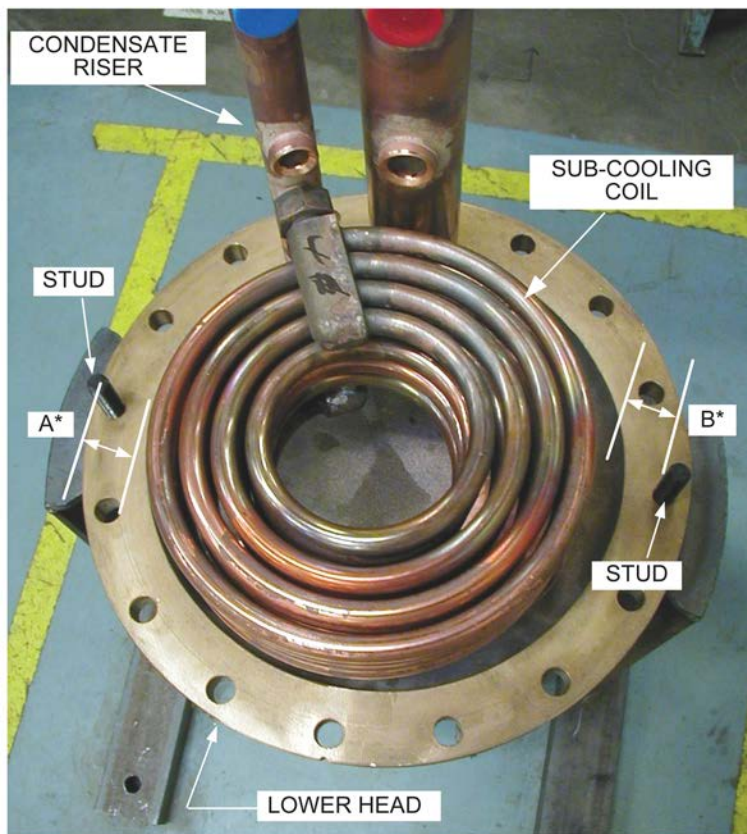

\* MEASUREMENTS A & B SHOULD BE EQUAL

**Figure 17: Sub-Cooling Coil Alignment**

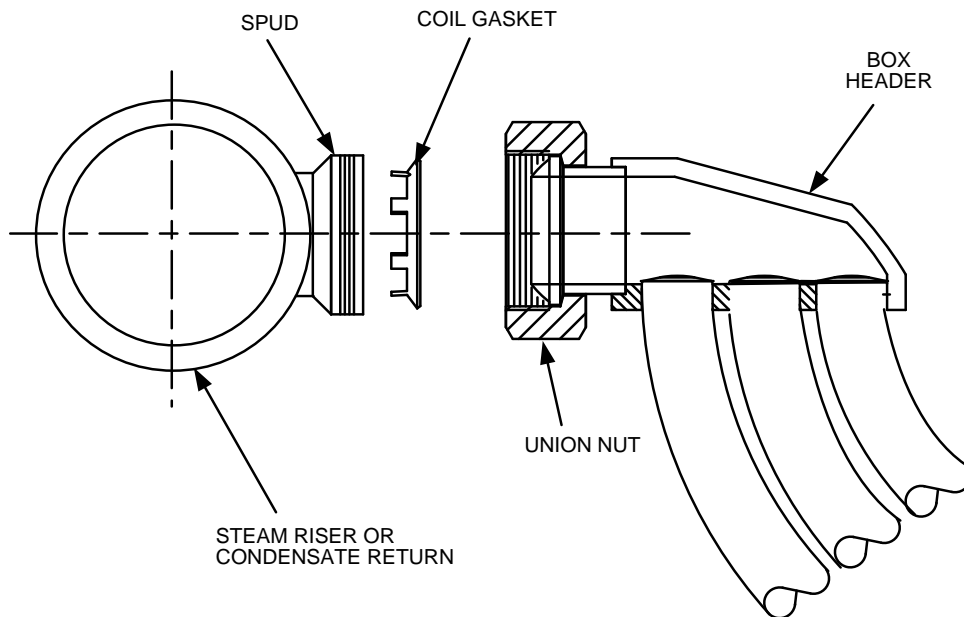

**Figure 18: Assembly of Coil to Steam Riser or Condensate Return**

## 12.2 SUB-COOLING COIL INSTALLATION

Install the Sub-cooling Coil as follows:

### Sub-cooling Coil Installation Instructions

- 1) For Wizard Sub-cooling Coil, align the Union Nuts with the two Spuds on the Condensate Riser.
- 2) Hand thread the Unions Nuts down to the seating surface.
- 3) Position the Coil to a level position.
- 4) Using the 75 ft/lb torque wrench, tighten the Union Nuts.
- 5) If the Union Nuts do not seat properly, remove the Sub-cooling Coil and re-clean all surfaces and threads on the Riser Spuds.

## 12.3 STEAM COIL INSTALLATION

Install the Steam Coil as follows:

### Steam Coil Installation Instructions

- 1) While holding the Steam Coil horizontally with the Union Nuts facing the Riser Spuds, hand thread the Steam Union Nuts onto the Spud. (Figure 7).
- 2) Hand thread the Condensate Union Nut onto the Spud.
- 3) Position the Coil horizontally.
- 4) Using a Carpenter's Square, check the vertical alignment to ensure that the Coil is installed inside the perimeter of the Shell. It is important that all coils in the bundle line up vertically and are positioned to ensure that they will not rub against the Liner of the Heater Shell.
- 5) If needed, use the appropriate Short-Length wrench to tighten the Union Nuts to a seating condition.
- 6) Insert the Coil Retaining tool through the first lower section of the Coil tubing. (Figure 8).
- 7) Using a Torque Wrench set for 75 ft-lbs, insert the wrench in the proper torque direction on the Union Nut (Figure 8).
- 8) Apply pressure to the Coil Retaining tool in the opposite direction of the pressure being applied to the Torque Wrench and tighten the Union Nut.
- 9) When the Torque Wrench setting "clicks", remove the Coil Retaining Tool.
- 10) Slowly reapply the pressure to the Torque Wrench holding the Coil by hand until the setting "clicks". If the Coil rotates during this operation, reinsert the Coil Retaining Tool and carefully apply a little more torque.
- 11) Once again, reapply the pressure to the Torque Wrench without holding the Coil until the setting "clicks".
- 12) Repeat step 11 until the Torque Wrench setting "clicks" without rotating the Union Nut or twisting the Coil.
- 13) Using the Coil Spacing Tool, perform a final spacing check of the Coil tubing by creating uniformed gaps between the Coil tubes (see Figure 4). Check for spacing between the Box Header and Return Bend. If the Return Bend is touching the Box Header, use the Coil Spacing Tool to separate the two components. Check for spacing between the Coil tubes above and below the Box Header. Create clearance using the Coil Spacing Tool.
- 14) Recheck all Union Nuts for the 75 ft/lbs setting without holding the Coil.
- 15) If a Union Nut or Coil rotates during this step, repeat steps 10 and 11.



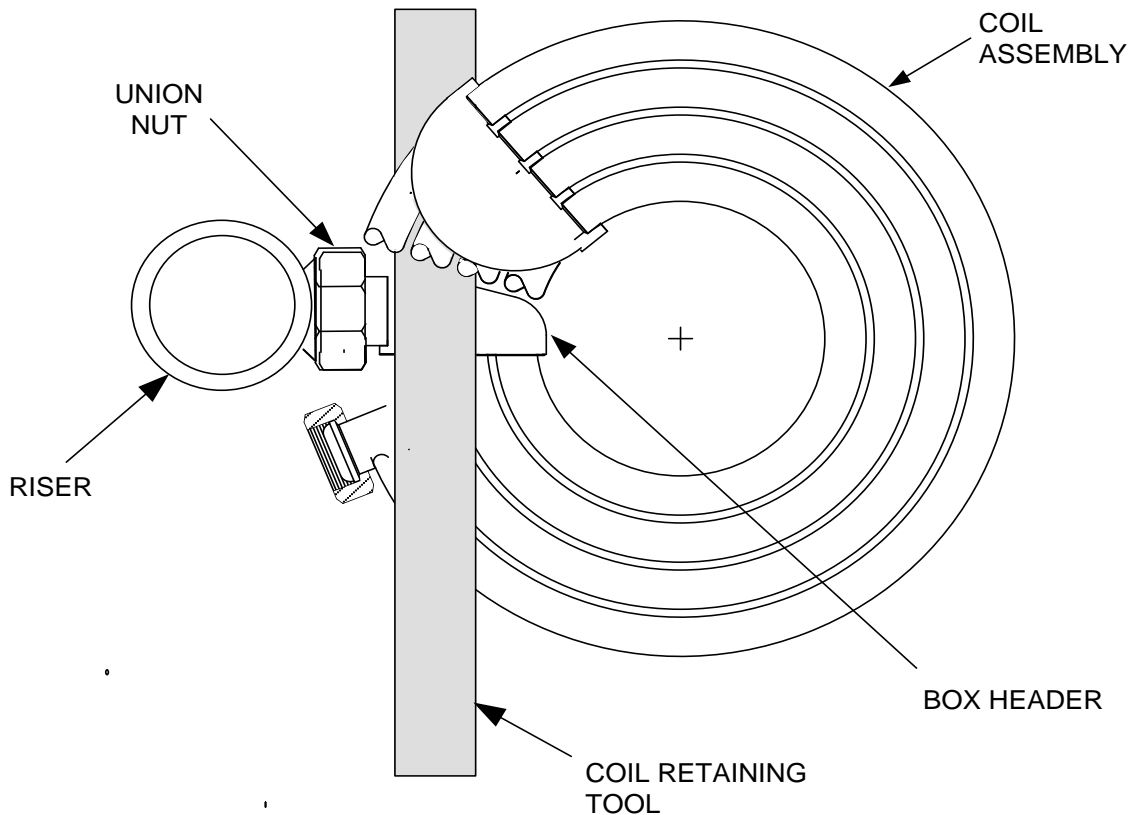

**TOP VIEW (PARTIAL CUT-AWAY)**

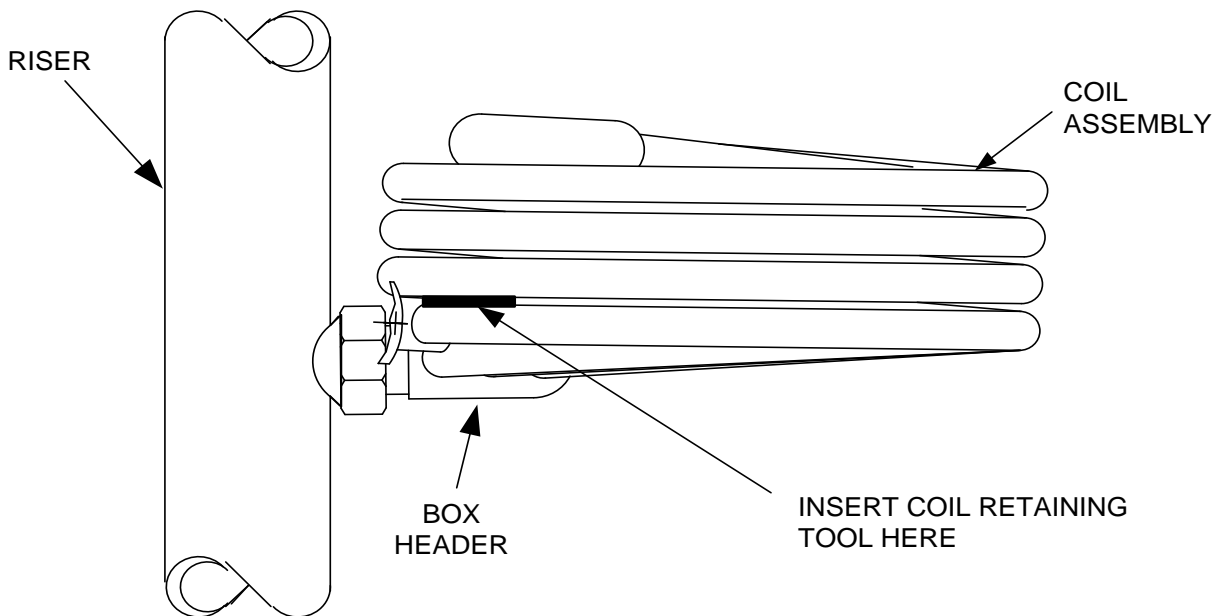

**SIDE VIEW**

**Figure 19: Positioning of Coil Retaining Tool**

## 12.4 Hydrostatically Testing Coils & Risers

Test the Coils and Risers hydrostatically as follows:

### Hydrostatically Testing Coils & Risers

- 1) Install fittings into the inlet and outlet of the Bottom for the Risers that can supply a hydrostatic pressure source.
- 2) One fitting should have a valve for the release of internal air pressure.
- 3) The other fitting should be attached to a source to apply the maximum allowable working pressure, (MAWP) to the internal Coil and Riser Bundle.
- 4) Apply MAWP to the Coil Bundle.
- 5) Close off both inlet and outlet valves to retain the internal pressure for 20 minutes.
- 6) If leaks are detected, remove the internal pressure.
- 7) Remove the leaking Coil and inspect for causes for leak.
- 8) If the leak is due to debris, clean the Coil and reinstall.
- 9) If there are damages to any surfaces, contact your AERCO Representative for instruction for returning the failed Coil.

## 12.5 Anticipator Check Valve Reassembly

Reassemble the Anticipator Check Valve assembly as follows:

### Anticipator Check Valve Reassembly

- 1) Insert the Valve Plug (36), the Washer (35), the Spring (34), and the Gasket (32). AERCO recommends that a new Gasket (32) be use whenever the Check Valve is reassembled.
- 2) Insert the Spring Plate Assembly (33), taking care to center it as closely as possible.
- 3) Line up the Outlet Flange (31) on the Studs (50) in the Heater top head, making sure that the Spring Plate Assembly (33) is centered in its groove in the bottom of the Outlet Flange (31).
- 4) Replace the Nuts (51) and tighten the Outlet Flange (31) leak-tight to the Heater top head.
- 5) If this is the only reassembly operation, reconnect the hot water outlet piping union and place the Heater back into operation in accordance with **Steps 1, 12, and 13** under **OPERATING PROCEDURES** above.

**12.6 Reassembly of Shell**

Reassemble the Heater Shell assembly as follows:

**Reassembly of Shell Instructions**

- 1) Install fittings into the inlet and outlet of the Bottom for the Risers that can supply a hydrostatic pressure source.
- 2) One fitting should have a valve for the release of internal air pressure.
- 3) The other fitting should be attached to a source to apply the maximum allowable working pressure, (MAWP) to the internal Coil and Riser Bundle.
- 4) Apply MAWP to the Coil Bundle.
- 5) Close off both inlet and outlet valves to retain the internal pressure for 20 minutes.
- 6) If leaks are detected, remove the internal pressure.
- 7) Remove the leaking Coil and inspect for causes for leak.
- 8) If the leak is due to debris, clean the Coil and reinstall.
- 9) If there are damages to any surfaces, contact your AERCO Representative for instruction for returning the failed Coil.

**12.7 Reinstalling Heater in Facility**

Reassemble all components that were disconnected in paragraph 5.2. When re-installing the Thermal Element into the Thermal Well Bushing in the Top Head, be careful not to damage the Element against the internal Coils. Straighten the Element before inserting.

**12.8 Startup Procedure**

Follow the operating procedure in Chapter 4: Start-Up Operation in document AC-103, OMM-0001 *Pneumatic Temperature Controller*. If you are using electronic controls, refer to document AC-105, OMM-0003 *Electronic Control System (ECS) and Type CXT-E Electronic Valve*.

**CHAPTER 13. RECOMMENDED SPARE PARTS**

<b>LIST A – For Any Model B+II Water Wizard Heater</b>			
<b>Quantity Per Heater</b>	<b>Part Name</b>	<b>Item No.</b>	<b>Shown in Figure No.</b>
1	Dial Thermometer	3	15
1	Temperature Switch	5	15
1	Compound Pressure Gage	12	15
1	Green Indicator Light	24	15
1	Red Indicator Light	25	15
2	Outlet Flange Gasket	32	16
4	Head Gasket	54	16
*	Coil Assembly	56	16
**	Conical Coil Gasket	57	16
* Minimum of 2 to a maximum of the number in your largest Heater			
** 2 per Space Coil Assembly, Item 56, plus 2			

<b>LIST B – For Model B+II Water Wizard with Pneumatic-Operated Control Valve</b>			
<u>List A above plus:</u>			
<b>Quantity Per Heater</b>	<b>Part Name</b>	<b>Item No.</b>	<b>Shown in Figure No.</b>
1	Temperature Controller	2	15
1	Air Solenoid Valve	11	15
1	P&T Relief Valve***	73	17
1	Water Solenoid Valve	79	17
2	Asbestos Flange Gasket****	97	17

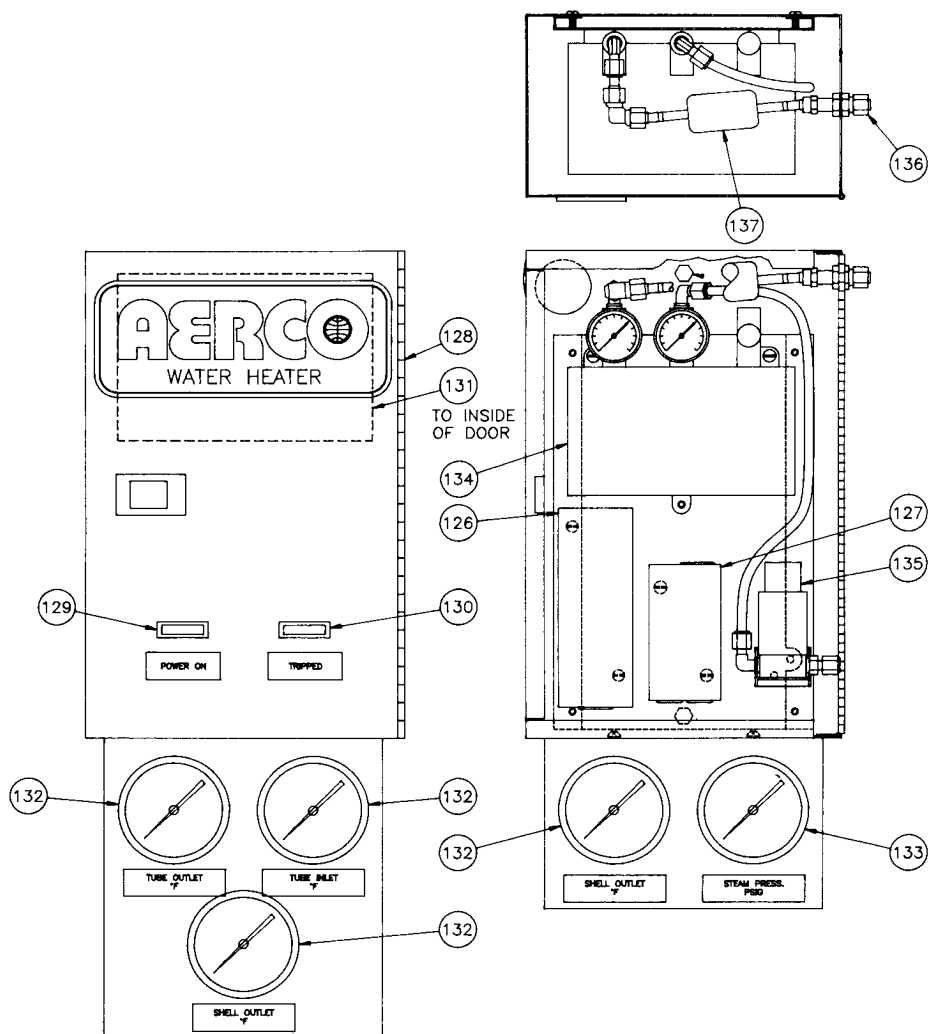

137	122679	1	IN-LINE AIR FILTER (AIR-OP VA.)
136	8-37	1	1/4" BULKHEAD UNION CONN (AIR-OP VA.)
135	9537	1	AIR SOLENOID VALVE (AIR-OP VA.)
134	18557	1	TEMPERATURE CONTROLLER (AIR-OP VA.)
133	121602-□	A/R	2-1/2" DIAL PRESSURE GAUGE (S/W ONLY)
132	12953-□	A/R	2-1/2" DIAL THERMOMETER
131	121992	1	WIRING DIAGRAM LABEL
130	121948	1	RED INDICATOR LIGHT
129	121949	1	GREEN INDICATOR LIGHT
128	20789	1	CONTROL BOX
127	121299	1	ELECTRICAL JUNCTION BOX
126	5131-1	1	TEMPERATURE SWITCH
ITEM	PART NO.	REQ	DESCRIPTION
PARTS LIST#1 (COMMON PARTS)			

**Figure 20 – AERCO Model SW1B+II Control Box Assembly and Parts List**

SIZE	ITEM 63 STM. IN. ASS'Y	ITEM 64 STM.TO VA.ASS'Y
1"	18874	-
1-1/4"	18874	-
1-1/2"	18874	-
2"	18874	-
2-1/2"	16955-2.50	16983
3"	16955-3.00	16984
4"	16955-4.00	16985

73	5134	1	WATER SOLENOID
71	8-40	1	1/4" 90° COMP. FTG. (AIR-OP. VA. ONLY)
70	RM3041	A/R	1/4" IMPOLENE TUBE (AIR-OP. VA. ONLY)
69	RM6031	A/R	1/2"OD TYPE "K" COPPER TUBE
68	12867	1	1/2"OD TUBE x 1/4"NPT 90° COMP. FTG.
67	122030-□	A/R	RELIEF VALVE OPTIONS
66	8-38	1	3/8" x 1/2" HUB ST. COND. CONN.
65	RM2000	A/R	3/8" TYPE LT CONDUIT
64	SEE TABLE	1	STEAM INLET TO VALVE ASSEMBLY
63	SEE TABLE	1	STEAM INLET ASSEMBLY
62	5143	1	THERMAL WELL BUSHING
61	RM6041	A/R	3/8"OD TYPE "L" COPPER TUBE
60	8-3	1	3/8"OD TUBE x 1/4"NPT 90° COMP. FTG.
59	8-65	1	1/2"OD TUBE x 1/4"NPT STR. COMP. FTG.
58	12820-13	1	2"NPT BALL VALVE
57	A/R	1	CONTROL VALVE
56	9-402	1	1"NPT STREET ELBOW
55	5001	1	1" UNION DRIFICE
54	9-331	1	1"NPT CLOSE NIPPLE
53	12757	1	1" CHECK VALVE
52	18840-□	1	CONTROL BOX ASSEMBLY
51	201004-□	1	B+II HEATER ASSEMBLY
ITEM	PART NO.	REQ	DESCRIPTION
PARTS LIST (COMMON PARTS)			

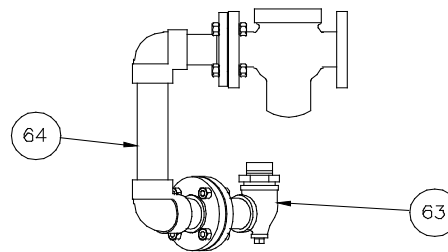
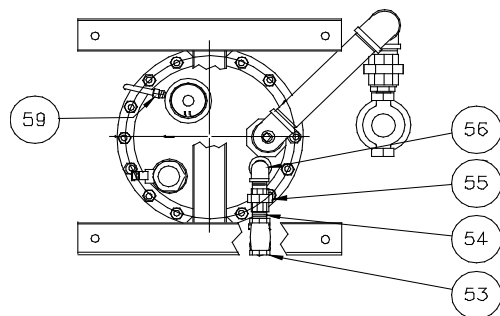
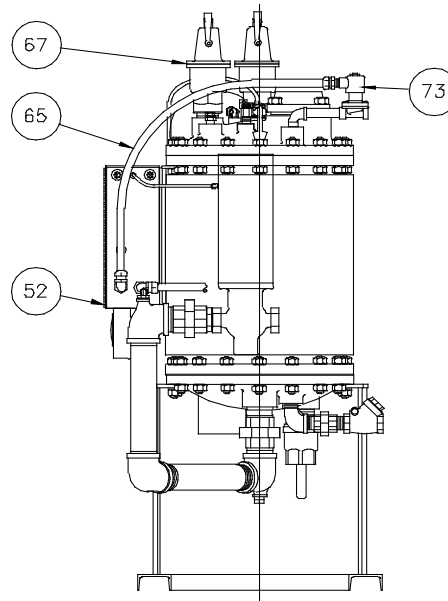
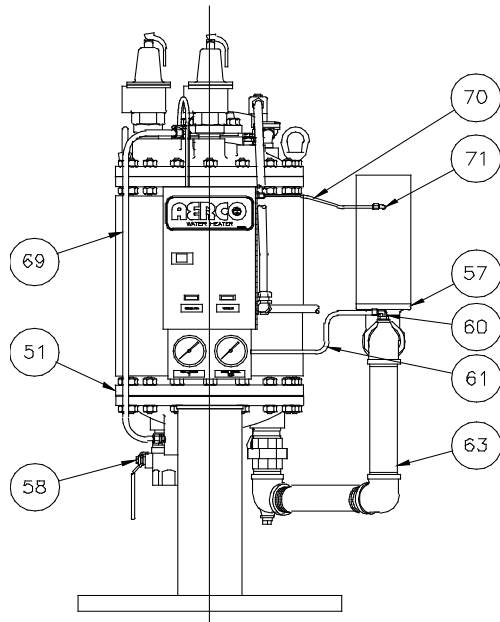
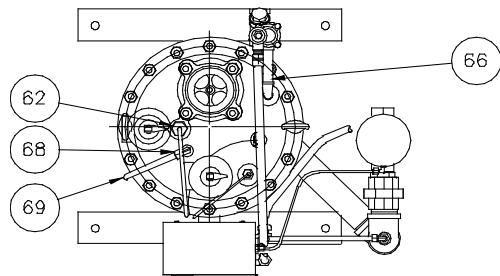

**Figure 21 – AERCO Model B+II Water Heater w/Pneumatic Valve - Assembly and Parts List**

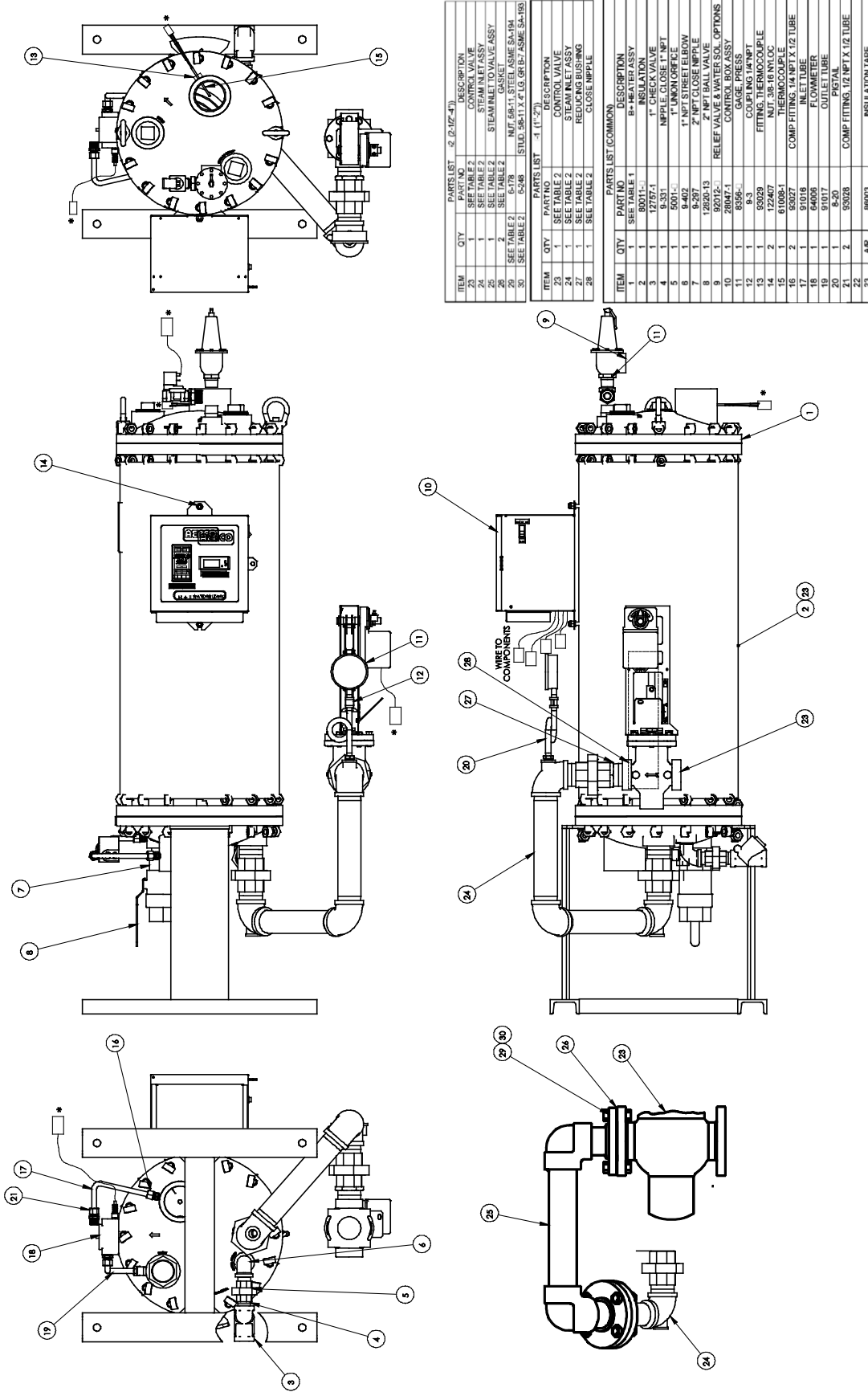

Figure 22 – AERCO Model SW1B+II Water Heater with ECS – Assembly and Parts List

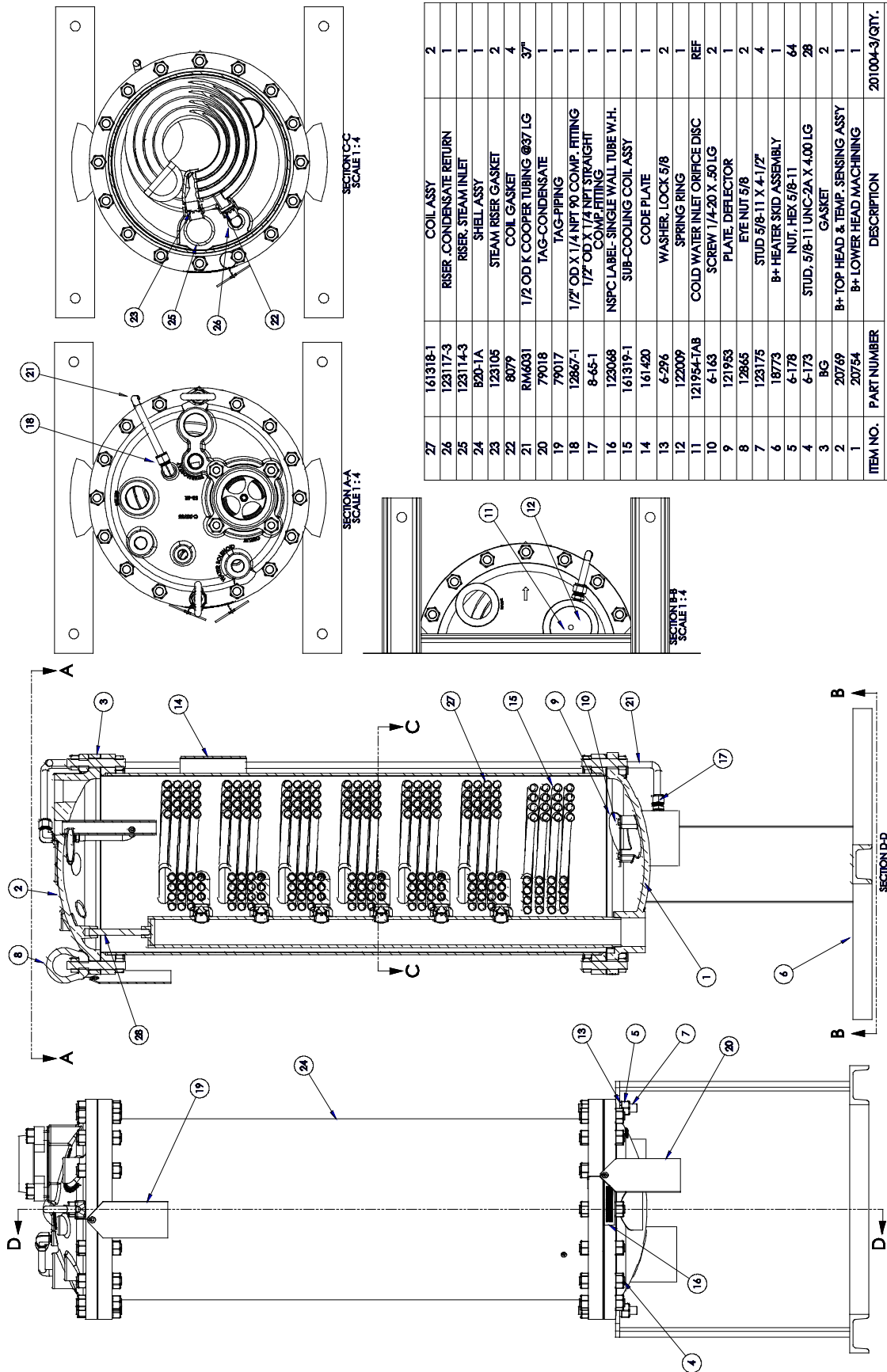

Figure 23 – AERCO Bare Replacement Heat Exchanger for Model SW1B+II – Assembly and Parts List



# NOTES:

## Change Log:

Date	Description	Changed by
11/28/2018	<b>Rev D:</b> Clarified reference to Startup procedure in Section 12.8 Startup Procedure.	Chris Blair

