

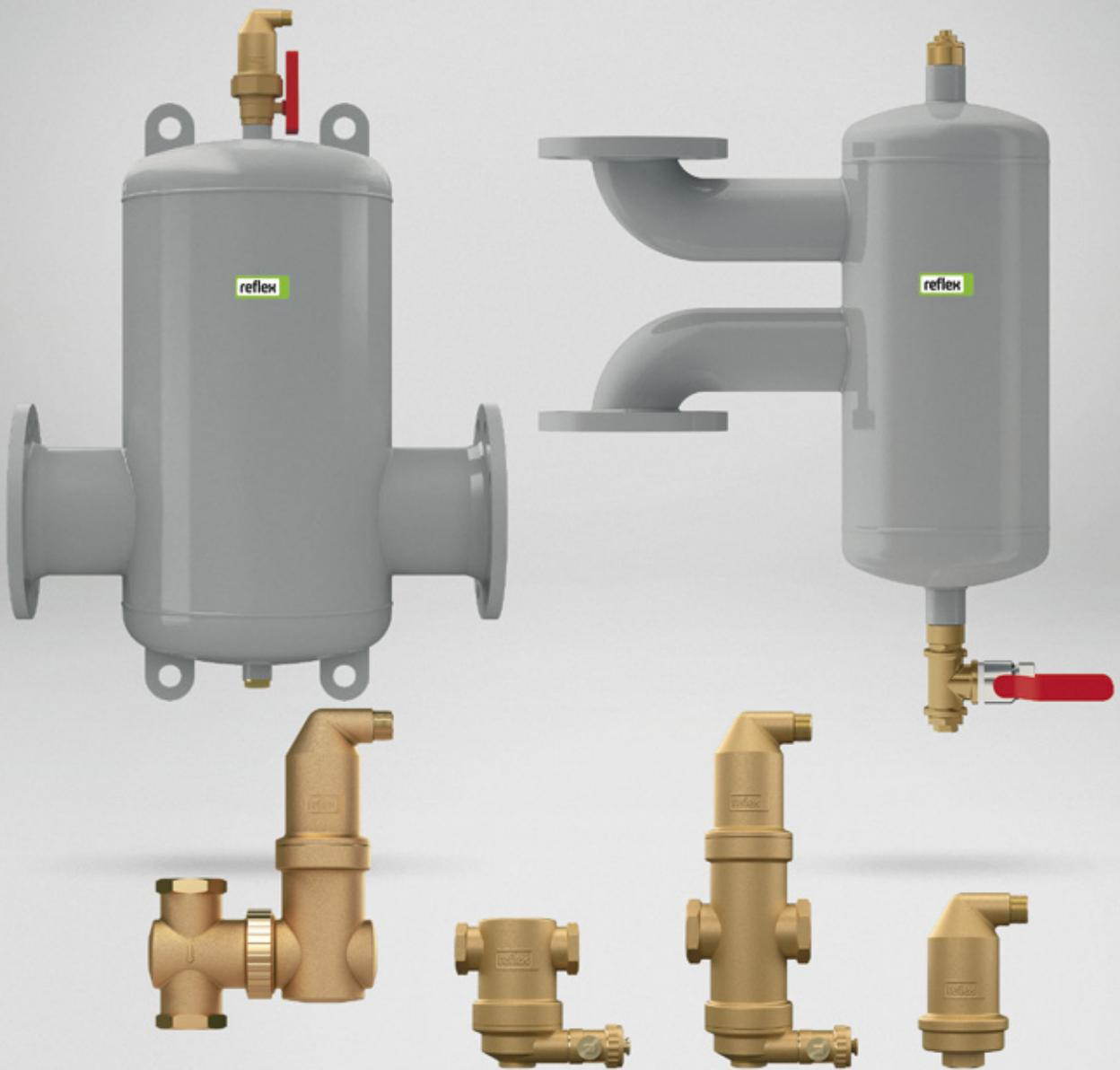

Thinking solutions.

Separation technology



Exvoid, Exdirt, Extwin

Reflex— a powerful brand for decades

Reflex Winkelmann GmbH—part of the Building+ Industry division—is a leading provider of highquality heating and hot water supply technology systems. Under its Reflex brand, the company, which has its headquarters in Ahlen in the German region of Westphalia, develops, produces and sells not only diaphragm expansion vessels, but also innovative components and holistic solutions for pressure maintenance, water make-up, degassing and water treatment, storage water tanks and plate heat exchangers, as well as hydraulic manifold and tank components. Reflex Winkelmann GmbH has about 2,000 employees worldwide, giving it an international presence in all major markets.

With its energy-efficient and sustainable products, the company is already doing its bit to help the environment, as evidenced by its commitment to sustainability and the climate policy goals agreed by the German Federal Government. This support is built on proven technologies and future-oriented innovations. What's more, Reflex Winkelmann GmbH works together with others as equals, always maintains its focus on the customer and offers additional services such as its own factory service centre fleet and a comprehensive range of training options.





Contents

Reflex City	P. 4
Separation technology	
Separation technology	P. 6
Separation technology made by Reflex	P. 7
Selection and dimensioning	P. 8
Exvoid	
Key advantages	P. 10
Construction, function and installation	P. 11
Product range	P. 14
Exdirt	
Key advantages	P. 18
Construction, function and installation	P. 19
Product range	P. 21
Extwin	
Key advantages	P. 28
Construction, function and installation	P. 29
Product range	P. 30
Accessories and add-on products	P. 34
Customised solutions	P. 37
Services	P. 38

New configuration software



Reflex Solutions Pro
rsp.reflex.de/en

→ Read more on [page 38](#)

Reflex City





Exdirt V

High-performance air, dirt and sludge separator

Living, shopping, working, manufacturing: cities are synonymous with diversity. The requirements for supply technology are as individual as the buildings themselves. Whether it's a 5 kW facility in a detached home or a safety-related cooling system in a computer centre—Reflex offers products and solutions for systems of all sizes and complexities. As shown in our Reflex City concept.

The safety and efficiency of the facilities in any type of building can be optimised by removing foreign matter—such as air, micro-bubbles, dirt and sludge from the system water. The Ex separators made by Reflex are an extensive range of high-performance air, dust and sludge separators in the full range of sizes and for any conceivable installation situation. They can be customised to individual requirements, if necessary.

Separation technology

There are a number of factors that contribute to the smooth running of a heating and cooling system. Air, micro-bubbles, dirt and sludge, for example, can have a significant detrimental effect on functional reliability as they reduce energy transmission efficiency and create the risk of corrosion. This inevitably results in further impairment, such as damages to expensive system parts or

total failure of the facility. Reflex venting and separation technologies reliably extract gas bubbles, dirt and sludge particles from the system, thus significantly improving water quality. Resulting in enhanced operational reliability, a longer service life, less maintenance and enhanced energy transmission efficiency. A distinction is made between:

Exvoid T

Venting free gas bubbles and air pockets
Venting is the term used to describe the elimination of air pockets from a system. They can occur, for example, while filling the system during commissioning or after repair work. Analysis has shown that undue care taken during filling can result in doubling the natural oxygen and nitrogen concentration in the water. On the one hand this leads to an increased risk of oxygen corrosion and on the other hand trapped residual air can hinder or entirely block circulation. Since air bubbles collect in high areas, quick air vents are installed in the high parts of a system.

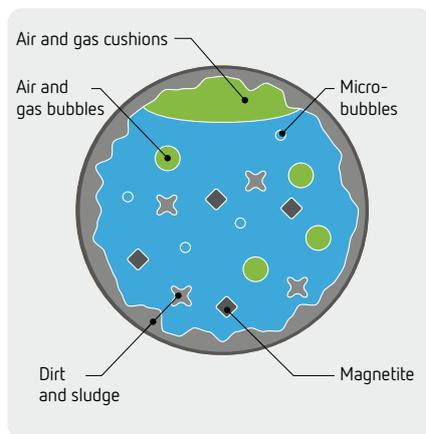

Cross section of a gas-enriched heating pipe

Exvoid

Separating air and micro-bubbles.
Micro-bubbles occur in heating, cooling and solar system wherever heat is generated and temperatures rise and where high flow speeds and pressure reduction coincide (any and all constrictions in a pipeline). If the micro-bubbles are left in the facility system, they collect in areas of low flow speeds and form larger gas and air cushions. Their avoidance is crucial to prevent malfunctions. Micro-bubble separators are predominantly integrated in facilities with low static heights. The basic principle applies that the higher the installation location and the warmer the medium, the better the functional performance.

Exdirt

Separating dirt and sludge. Dirt and sludge occur as a result of corrosion processes, or old, poorly cleaned pipelines. They are transported by the filling or make-up water into the system, or form as limestone during heating. The dirt particles build up inside pipes. They constrict flow cross sections, act as an insulating layer and exacerbate pressure loss, which then has to be compensated by increased pump performance. In addition, suspended particles and loose deposits may damage parts of the system, such as fittings and pumps. Dirt separators are integrated in the return flow of heat generators to prevent impurities from being carried along with the flow and settling in the system.

Exferro

Separating magnetic dirt particles (magnetite). Heating networks or piping systems made primarily of iron and steel materials are exposed to a constant risk of corrosion. It can be caused by a low pH value (acid water) or the content of dissolved oxygen. The resulting iron hydroxide $\text{Fe}(\text{OH})_2$ ("brown rust") and iron oxide Fe_2O_3 (haematite) is already extracted by the Exdirt. Magnetite forms at the third corrosion level. It can be separated particularly effectively using a special high-performance magnet for Exdirt and Extwin—the Exferro Easy Clip, a clip-on magnet for brass separators, and the Exferro magnetic insert for steel separators.

Extwin

Combined micro-bubble, dirt and sludge separation. Extwin is ideal for eliminating air bubbles, micro-bubbles, dirt and sludge from the system water at the same time. Extwin combines the functions offered by Exdirt and Exvoid in a single, compact unit. Like the micro-bubble separator, Extwin is used in facilities with low static heights.

Separation technology made by Reflex

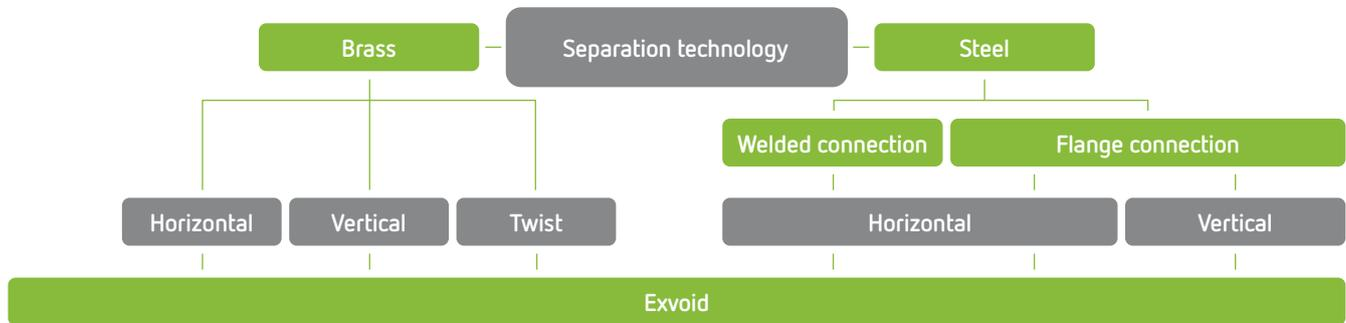

Automatic Air vent



T 1/2" / 3/8"
110°C/180°C

Micro-bubble air separator



A 22-2"
110°C/180°C



A 22-1" V
110°C/180°C



AT 22-1 1/2" V
110°C



A 60.3-A 323.9



A 50-A 600

Exdirt

Dirt and sludge separator



D 22-2"
110°C



D 22-1" V
110°C



D 60.3-D 323.9



D 50-D 600



DN 50 V-DN 150 V

With Exferro Easy Clip high-performance magnet



D 22-2"
110°C



D 22-1" V
110°C



DT 22-1 1/2" V
110°C



D 60.3 R-D 323.9 R



D 50 R-D 600 R

Exferro Magnetic insert (optional)

Extwin

Combined micro-bubble, dirt and sludge separator



TW 22-1"
110°C



TW 22 V
110°C



TW 60.3-TW 323.9



TW 50-TW 600

With Exferro Easy Clip high-performance magnet



TW 22-1"
110°C



TW 22 V
110°C



TWT 22-1 1/2" V
110°C



TW 60.3 R-TW 323.9 R



TW 50 R-TW 600 R

Exferro Magnetic insert (optional)

All horizontal steel separators are also available as Hi Cap version.

Selection and dimensioning

Find the right type quickly and easily

Whether you are looking for Exvoid, Exdirt or Extwin—the selection and dimensioning of the separators depends on the fluid's flow speed. The maximum possible volume flow for each size can be seen from the diagram and the table.

Pressure loss diagram: Exvoid/Exdirt/Extwin,

Standard types

Connection	K_{vs} [m ³ /h]	V_{max} [m ³ /h]	Connection	K_{vs} [m ³ /h]	V_{max} [m ³ /h]
Twist 22 mm & ¾"	10.5	1.25	DN 100	244.3	47.00
Twist 28 mm & 1"	12.2	2.00	DN 125	351.3	72.00
Twist 1 ¼"	18.8	3.70	DN 150	487.9	108.00
Twist 1 ½"	22.6	5.00	DN 200	780.6	180.00
IG 22 mm & ¾"	10.7	1.25	DN 250	1,096.4	288.00
IG 1"	17.2	2.00	DN 300	1,459.5	405.00
IG 1¼"	31.8	3.70	DN 350	1,790.3	500.00
IG 1½"	40.0	5.00	DN 400	2,242.7	650.00
IG 2"	56.1	7.50	DN 450	2,687.9	850.00
DN 50	72.2	12.50	DN 500	3,196.0	1,060.00
DN 65	121.7	20.00	DN 600	4,416.7	1,530.00
DN 80	158.5	27.00			

Pressure loss calculation for all flow rates

$$\Delta p = \left(\frac{\dot{V}}{K_{vs}} \right)^2 \cdot 1 \text{ bar}; \dot{V} \leq \dot{V}_{max}$$

Example: Heating circuit 70/55 °C; Heat generator output 40 kW

1. Volumetric flow calculation

$$\dot{V} = \frac{40 \text{ kW}}{4.2 \text{ kJ} / (\text{kg} \cdot \text{K}) \cdot (70 - 55) \text{ K}} \cdot 3,600 \frac{\text{s}}{\text{h}} \cdot \frac{1 \text{ m}^3}{1,000 \text{ kg}}$$

$$= 2.3 \text{ m}^3/\text{h} \rightarrow \text{Selection based on table: IG 1 ¼"} \\ \text{with } K_{vs} = 31.8 \text{ m}^3/\text{h}$$

$$\Delta p = \left(\frac{2.3 \text{ m}^3/\text{h}}{31.8 \text{ m}^3/\text{h}} \right)^2 \cdot 1 \text{ bar} = 5.23 \cdot 10^{-3} \text{ bar} \mid \cdot 100 \text{ kPa}/\text{bar}$$

$$\hat{=} 0.52 \text{ kPa}$$

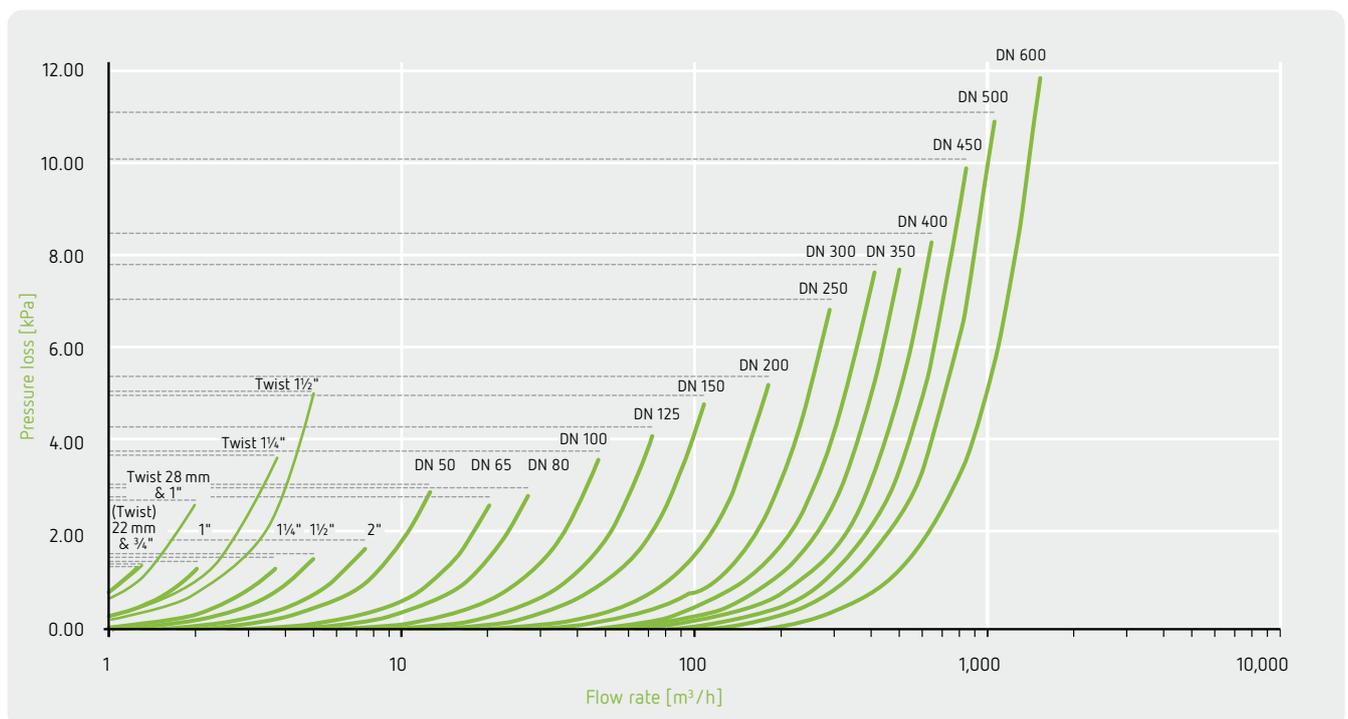

Pressure loss diagram: Exvoid/Exdirt/Extwin,

Hi-Cap types

- All Reflex steel separators are also available as Hi-Cap versions
- The Hi-Cap types offer high flow rates
(Flow speeds between 1.5 m/s and 3.0 m/s)
- The larger body takes account of the change in flow behaviour at higher flow rates

Connection	K_{VS} [m³/h]	V_{max} [m³/h]	Connection	K_{VS} [m³/h]	V_{max} [m³/h]
DN 50	72.2	25.0	DN 250	1,096.4	576.0
DN 65	121.7	40.0	DN 300	1,459.5	810.0
DN 80	158.5	54.0	DN 350	1,790.3	1,000.0
DN 100	244.3	94.0	DN 400	2,242.7	1,300.0
DN 125	351.3	144.0	DN 450	2,687.9	1,700.0
DN 150	487.9	216.0	DN 500	3,196.0	2,120.0
DN 200	780.6	376.0	DN 600	4,416.7	3,060.0

Pressure loss calculation for all flow rates

$$\Delta p = \left(\frac{\dot{V}}{K_{VS}} \right)^2 \cdot 1 \text{ bar}; \dot{V} \leq \dot{V}_{max}$$

Example: Cooling circuit 7/12 °C; Cooling output 200 kW

1. Volumetric flow calculation

$$\begin{aligned} \dot{V} &= \frac{200 \text{ kW}}{4,2 \text{ kJ/kg} \cdot (12 - 7) \text{ K}} \cdot 3,600 \frac{\text{s}}{\text{h}} \cdot \frac{1 \text{ m}^3}{1,000 \text{ kg}} \\ &= 34.3 \text{ m}^3/\text{h} \rightarrow \text{Selection based on table: DN 65} \\ &\quad \text{with } K_{VS} = 121.7 \text{ m}^3/\text{h} \end{aligned}$$

$$\begin{aligned} \Delta p &= \left(\frac{34.3 \text{ m}^3/\text{h}}{121.7 \text{ m}^3/\text{h}} \right)^2 \cdot 1 \text{ bar} = 7.94 \cdot 10^{-2} \text{ bar} \mid \cdot 100 \text{ kPa/bar} \\ &= 7.94 \text{ kPa} \end{aligned}$$

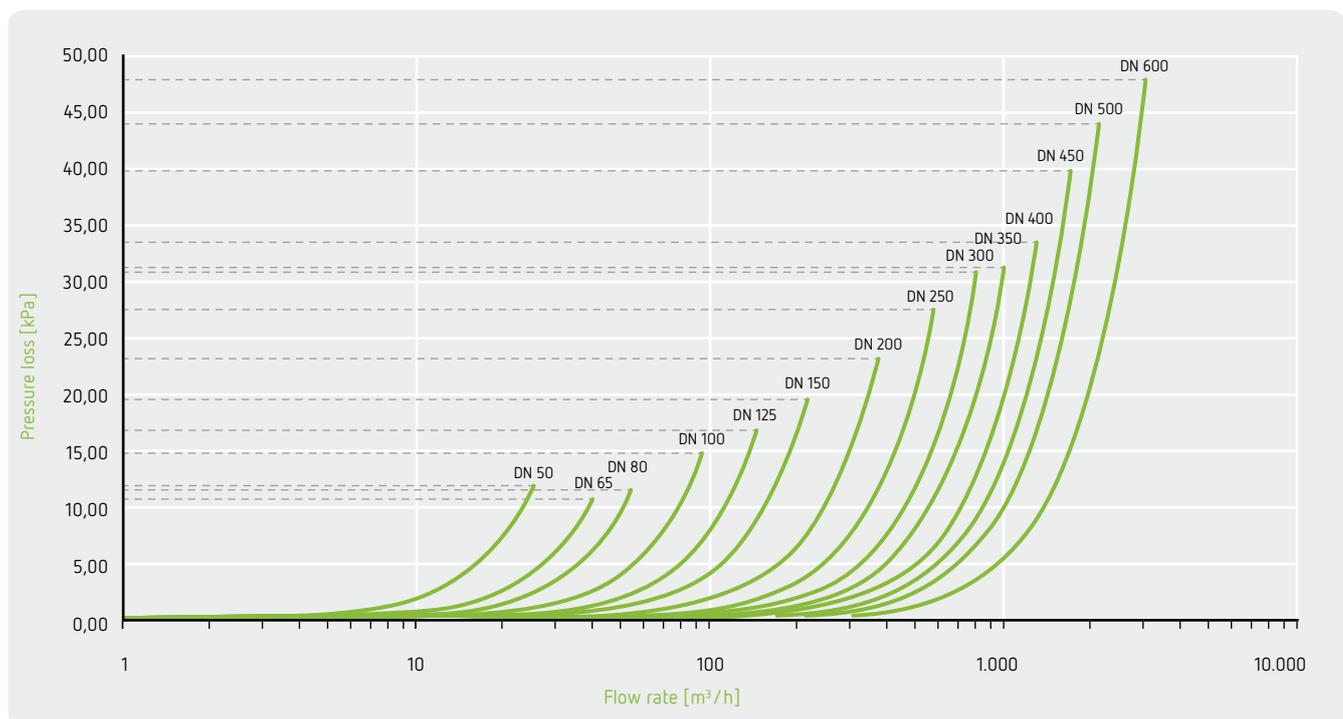

Key advantages

Exvoid T large and quick air vent

- Reliably assures the automatic elimination of air and other gas pockets in heating, solar and cooling systems
- Prevents flow noises, disruptions to circulation, performance impairment and avoidable corrosion damage
- Reduces the need for maintenance
- Suitable for various temperatures and applications

Exvoid air and micro-bubble separator

- Extracts circulating free air and gas bubbles from heating, solar and cooling systems and when filling and draining new and existing facilities
- Fully automatic continuous operation
- Generates only a minimal, constant pressure drop
- Enables much faster hydraulic balancing after filling processes
- Protects against noise, corrosion wear and impaired performance caused by the formation of larger air pockets

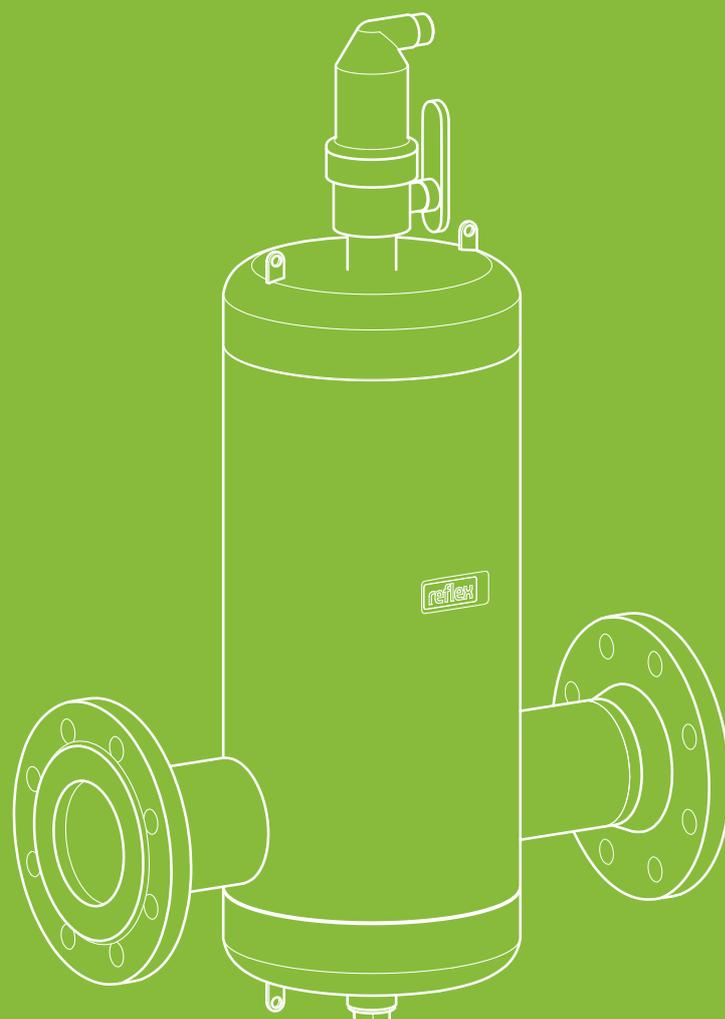

* 5 years guarantee for brass separators from date of manufacture.
Please consider the guarantee conditions and guidelines at www.reflex-winkelmann.com/en

Construction, function and installation

Exvoid T Large and quick vent valves

Construction

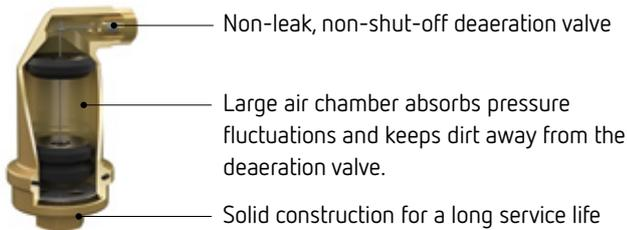

Exvoid T (brass type)

Exvoid Air and microbubble separator

Construction

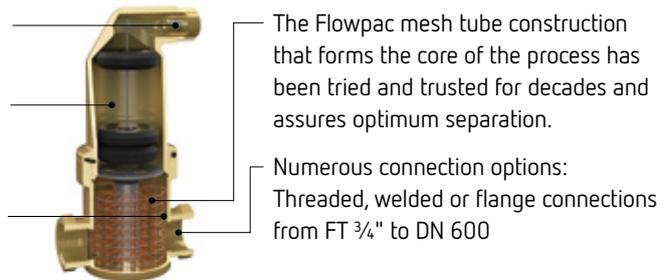

Exvoid (brass type)

Exvoid T function principle



Exvoid T (brass type)

Intelligent design engineering guarantees permanently reliable automatic operation:

1. Gas is collected in a large chamber.
2. As a result, the water level in the chamber drops, taking a float down with it.
3. Once the float has sunk to a certain level, it opens the deaeration valve.

The combination of the valve, which is subjected to fourfold testing, and the large air chamber assure reliable operation, even if pressure fluctuates enormously or the medium is very dirty.

Exvoid function principle

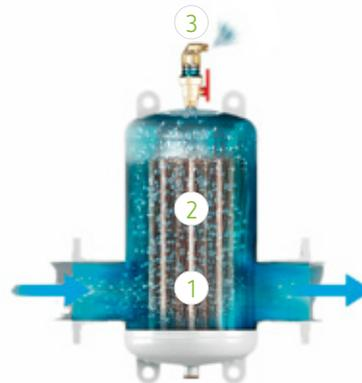

Exvoid (steel type)

As micro-bubbles are carried in the flow, special measures are needed to remove them efficiently.

1. The cross section of the housing is larger than the connection dimensions, which reduces flow speed in the separator.
2. At the same time, the flow is passed through a special wire mesh. The resulting turbulence excites gas bubbles to move in an indeterminate direction.
3. Depending on the flow rate, density and volume of the particles, the natural settling of some of the gas bubbles is supported. Micro-bubbles that are moving freely and have settled on the Flowpac mesh tube join, rise and are discharged from the system through the upper vent.

Exvoid T Large and quick vent valves

Installation

Installation location

Automatic vents, suitable for any facility, for initial venting or venting after repairs. They are installed at all relative and absolute highest points or in collection areas designed specifically for the purpose.

- Facilities must be carefully vented at the highest points during filling, e.g. using Exvoid T quick air vents. Exvoid T vents help to partially automate the venting process. They are used to vent boilers and ensure that the water is kept free from air and that heat transfer is optimised. At the end of venting, the water level rises sufficiently to automatically close them.
- Exvoid T must always be installed in accessible areas, do not cover them with insulation! Make sure the piping gradient is appropriate.
- The facility must be filled at a flow rate \dot{V} to prevent any noticeable increase in pressure in the system when air is discharged through the vents. The flow rate must be smaller than the rated volumetric flow: $\dot{V} \leq \sum \dot{V}_N$.

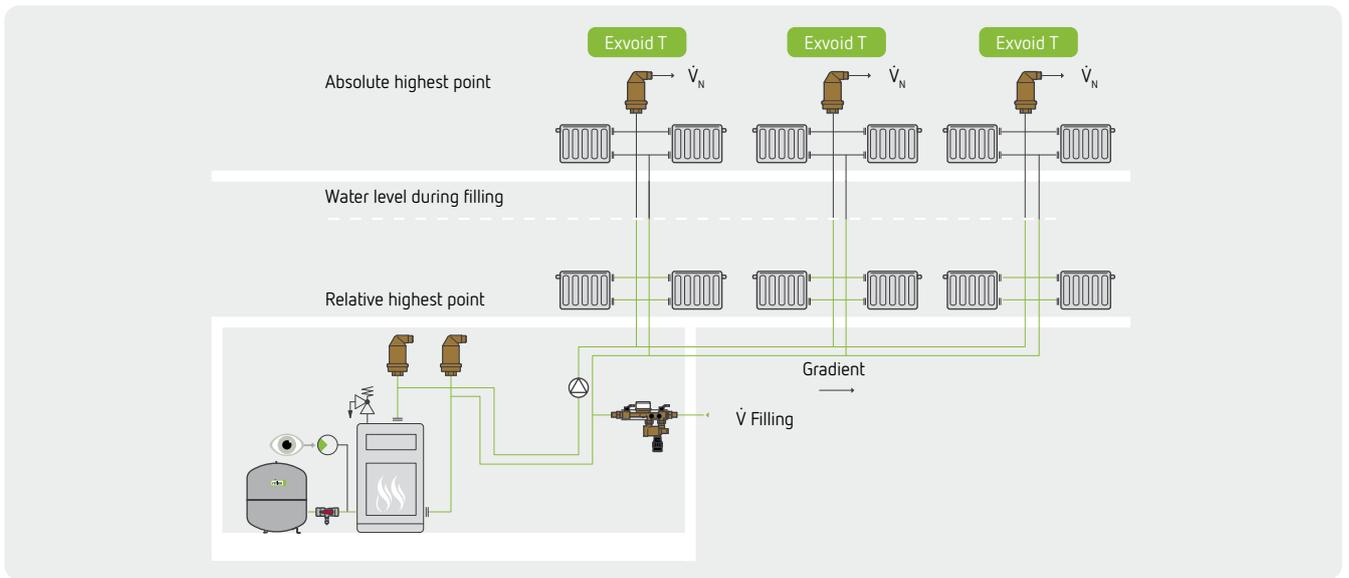

Displacement venting using Exvoid T in a heating system

Special vents with higher permissible temperatures must be used in solar systems. These vents must be shut off during operation to prevent the risk of steam which forms in the collector escaping out through the vent.

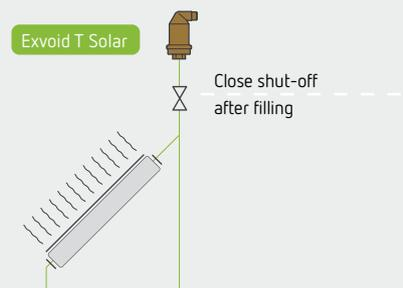

Displacement venting using Exvoid T Solar in a solar system



The installation of a Reflex Servitec vacuum spray-tube degassing is recommended to ensure an absolutely air- and gas-free system as well as the removal of dissolved gases.

Exvoid T Large and quick vent valves

Installation

Installation location

In a heating system: right after the boiler upstream of the pump; in a cooling system: upstream of the cold generator in the return flow.

- Gas is released at higher pressures and temperatures. Micro-bubble separators therefore need to be installed at the hottest point; right after the boiler or mixing valve in a heating system and upstream of the cold generator in the return flow in a cooling system. Exvoid must be installed upstream of any bypass.
- It is installed right next to the heat generator or cooling source, in areas such as roof central heating systems or technical centres located in high places, air collecting points and all areas where pressure- or temperature-related degassing processes take place.
- Relative to the gas concentration in the water, installation is ideal at high points where dissolved gases may be released. This is, however, often difficult to implement in practice as rising pressure can cause free gases to dissolve again right beneath the highest point. So the functional reliability of micro-bubble separators can be impaired just 5 metres below the highest point. The basic principle applies that the higher the installation location and the warmer the medium, the better the functional performance.

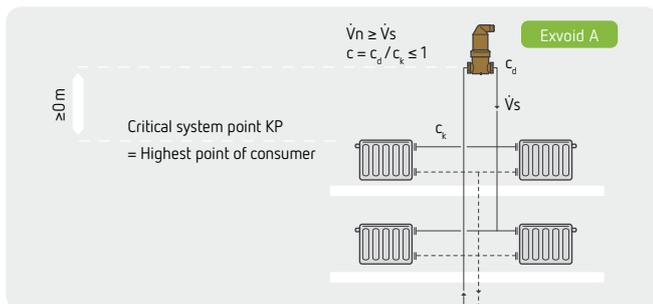

Exvoid A micro-bubble separator at the highest point (or higher)

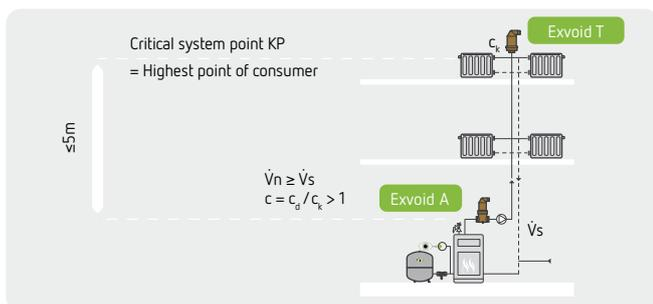

Exvoid A micro-bubble separator beneath the highest point

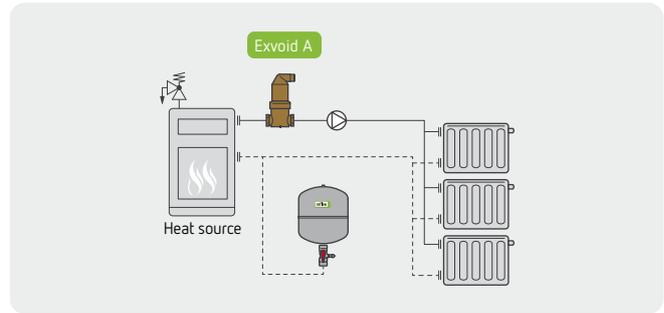

Exvoid (brass) in a heating system

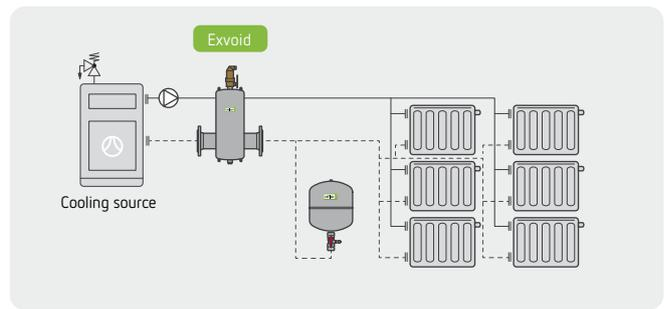

Exvoid (steel) in a cooling system

Observe the critical system point during installation

Critical system point (KP) describes the point during operation at which the greatest risk of bubble formation exists, which must, however, be prevented to avoid malfunctions. The pressure at the critical system point has been specified as 0.5 bar, which is equivalent to the minimum requirements for highest points at temperatures < 100 °C. The pressure must be provided via supply pressure p_s by the pressure maintenance system.

Exvoid A micro-bubble separator at the highest point (or higher)

Installing at the level of the critical system point or above it (as shown in the illustration) offers two advantages:

The micro-bubble separator can act as a vent as well when filling the facility, and adherence to the recommended nitrogen limits relevant to stationary gas content in facility water is assured.

Exvoid A micro-bubble separator beneath the highest point

In smaller, compact facilities with short flow paths, installation of the micro-bubble separator up to 5 metres below the critical system point can be tolerated. The installation of Exvoid T at the critical system point is then recommended. The recommended nitrogen limits c_k at installation location where gas content is c_d is then no longer possible.

Exvoid product range

Exvoid T Large and quick vent valves

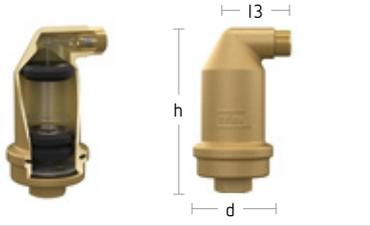

Technical features

- Fourfold tested venting valve for superb operational reliability
- For vertical installation
- System connection FT 1/2" and MT 3/8" incl. one 1/2" connecting thread on the venting valve

Exvoid T

	Type	Art. No.	DG	PQ [pce]	Connection c	Ø d [mm]	Height h [mm]	Length l3 [mm]	Weight [kg]
Brass, Vertical									
10 bar 110 °C	T 1/2	9250000	0082	12	IG 1/2"	63	122	46	0.63
	T 3/8	9250038	0082	12	AG 3/8"	63	132	46	0.73
Solar, Brass, Vertical									
10 bar 180 °C	T 1/2 S	9250600	0082	12	IG 1/2"	63	122	46	0.64
	T 3/8 S	9250638	0082	12	AG 3/8"	63	132	46	0.67

Exvoid Air and microbubble separator

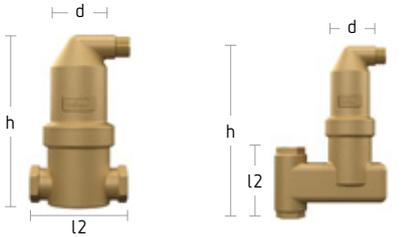

Technical features

- Connection diameter: A22–2" (DN 20–DN 50)
- Flow rate: 1.25–8.0 m³/h (at v ≈ 1.0 m/s)
- Exiso heat insulation A22–2" (DN 20–DN 50)
- Application: up to 110 °C or 180 °C and 10 bar
- Installation position (solar up to 180 °C): horizontal, vertical

Exvoid horizontal

Exvoid vertical

	Type	Art. No.	DG	PQ [pce]	Connection c	V _{max} [m³/h]	Ø d [mm]	Height h [mm]	Length l2 [mm]	Weight [kg]
Brass, Horizontal										
10 bar 110 °C	A 22	9251000	0082	12	22 mm	1.2	63	165	99	1.08
	A 3/4	9251010	0082	12	IG 3/4"	1.2	63	165	85	1.03
	A 1	9251020	0082	8	IG 1"	2.0	63	182	88	1.12
	A 1 1/4	9251030	0082	8	IG 1 1/4"	3.8	63	202	88	1.23
	A 1 1/2	9251040	0082	8	IG 1 1/2"	5.0	63	236	88	1.44
A 2	9251050	0082	1	IG 2"	7.5	100	277	112	3.18	
Brass, Vertical										
10 bar 110 °C	A 22V	9251500	0082	8	22 mm	1.2	63	216	104	1.09
	A 3/4V	9251510	0082	8	IG 3/4"	1.2	63	206	84	1.90
	A 1V	9251520	0082	8	IG 1"	2.0	63	206	84	1.57
Solar, Brass, Horizontal										
10 bar 180 °C	A 22 S	9251600	0082	12	22 mm	1.2	63	165	99	1.20
	A 3/4 S	9251610	0082	12	IG 3/4"	1.2	63	165	85	0.94
	A 1 S	9251620	0082	8	IG 1"	2.0	63	182	88	1.10
	A 1 1/4 S	9251630	0082	8	IG 1 1/4"	3.7	63	202	88	1.40
	A 1 1/2 S	9251640	0082	8	IG 1 1/2"	5.0	63	236	88	1.43
Solar, Brass, Vertical										
10 bar 180 °C	A 22 SV	9251700	0082	8	22 mm	1.2	63	216	104	1.67
	A 3/4 SV	9251710	0082	8	IG 3/4"	1.2	63	206	84	1.90
	A 1 SV	9251720	0082	8	IG 1"	2.0	63	206	84	1.90

Exvoid Twist Air and microbubble separator



Twist separator connections are infinitely rotatable 360° (non-ratcheting), making them suitable for a wide range of different installation positions. The connection can be rotated by hand.



Exvoid Twist

Technical features

- Infinitely rotatable (non-ratcheting) brass separator for installation in any position
- Connection diameter: A 22–1 ½" (DN 20–DN 40)
- Volumetric flow: 1.25–5.0 m³/h (at v ≈ 1.0 m/s)
- Exiso heat insulation A 22–1 ½" (DN 20–DN 40)
- Brass casing
- Area of application: up to 110 °C
- Installation position: 360° infinitely rotatable (non-ratcheting)
- Water/glycol mixture up to a mixing ratio of 50 :50 (at least 25%)

	Type	Art. No.	DG	PQ [pce]	Connection c	V _{max} [m ³ /h]	Ø d [mm]	Height h [mm]	Length l2 [mm]	Weight [kg]
Twist, Brass, Rotatable										
10 bar 110 °C	AT 22	9257200	0092	6	22 mm	1.2	63	218	109	2.01
	AT 28	9257210	0092	6	28 mm	2.0	63	219	111	2.18
	AT ¾	9257220	0092	6	IG ¾"	1.2	63	207	85	1.90
	AT 1	9257230	0092	6	IG 1"	2.0	63	214	100	2.03
	AT 1 ¼	9257240	0092	4	IG 1 ¼"	3.8	63	264	100	2.64
	AT 1 ½	9257250	0092	4	IG 1 ½"	5.0	63	264	100	2.48

The Exiso heat insulation for the above separators can be found under accessories on page 35.

Exvoid Air and microbubble separator

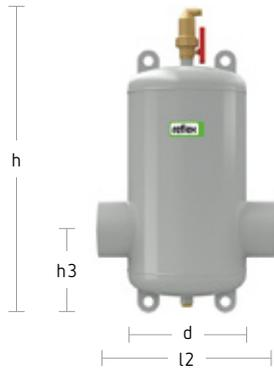

Exvoid Steel welded connection

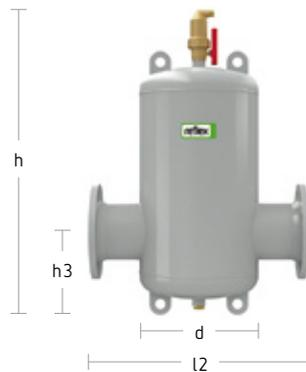

Exvoid Steel flange connection



Exvoid Steel cutaway model

Technical features

- Connection: DN 50 – DN 600
- Flow rate: 12.5 – 405 m³/h
- Exiso heat insulation: DN 50 – DN 150, other types and nominal diameters on request
- Steel housing
- Automatic venting with integrated shut-off valve
- Application: up to 110 °C and 10 bar, further pressure ratings and temperatures on request

	Type	Art. No.	DG	Connection c	V _{max} [m ³ /h]	Ø d [mm]	Height h [mm]	Height h3 [mm]	Height h6 [mm]	Length l2 [mm]	Weight [kg]
Painted steel, Flange											
10 bar 110 °C	A 50	8251300	0083	DN50/PN16	12.5	132	625	153	50	350	9.00
	A 65	8251310	0083	DN65/PN16	20.0	132	625	163	50	350	10.00
	A 80	8251320	0083	DN80/PN16	27.0	206	740	159	50	470	16.00
	A 100	8251330	0083	DN100/PN16	47.0	206	740	169	50	475	19.00
	A 125	8251340	0083	DN125/PN16	72.0	354	915	214	50	635	35.00
	A 150	8251350	0083	DN150/PN16	108.0	409	915	229	50	635	39.00
	A 200	8251360	0083	DN200/PN16	180.0	409	1.125	284	50	775	65.00
	A 250	8251370	0083	DN250/PN16	288.0	480	1.402	351	50	890	108.00
	A 300	8251380	0083	DN300/PN16	405.0	634	1.612	406	50	1.005	158.00
Painted steel, Welded connector											
10 bar 110 °C	A 60.3	8251100	0083	60.3	12.5	132	625	153	50	260	3.00
	A 76.1	8251110	0083	76.1	20.0	132	625	163	50	260	3.00
	A 88.9	8251120	0083	88.9	27.0	206	740	159	50	370	9.00
	A 114.3	8251130	0083	114.3	47.0	206	740	169	50	370	9.00
	A 139.7	8251140	0083	139.7	72.0	354	915	214	50	525	22.00
	A 168.3	8251150	0083	168.3	108.0	354	915	229	50	525	24.00
	A 219.1	8251160	0083	219.1	180.0	409	1,125	284	50	650	44.00
	A 237.0	8251170	0083	273.0	288.0	480	1,402	351	50	750	70.00
	A 323.9	8251180	0083	323.9	405.0	634	1,612	406	50	850	112.00

Other designs (higher operating temperatures, higher operating pressures) are available upon request.

Exvoid Hi-Cap Air and microbubble separator

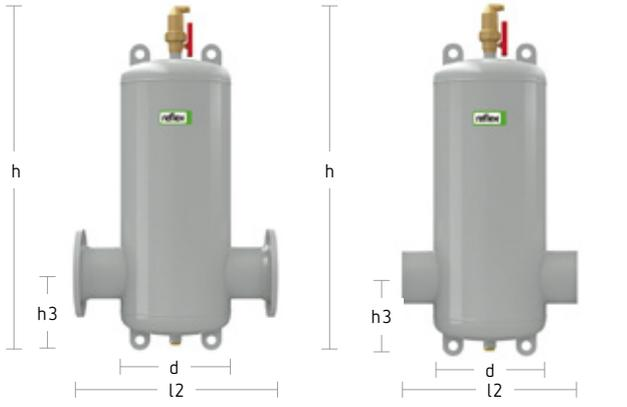

Exvoid (steel) Hi-Cap
flange connection

Exvoid (steel) Hi-Cap
welded connection

Higher flow rates cause the flow characteristics to change on entry into the body. The flow and idle zones shift. Enlarging the body enables optimum incorporation of this change in flow behaviour to ensure continued assured maximum separation performance in the high flows.



Technical features

- For high flow rates and high flow speeds up to 3 m/s
- Connection: DN 50–DN 600
- Flow rate: 25–3,000 m³/h
- Steel housing
- Application: up to 110 °C and 10 bar, further pressure ratings and temperatures on request

	Type	Art. No.	Connection c	V _{max} [m ³ /h]	Ø d [mm]	Height h [mm]	Height h3 [mm]	Length l2 [mm]	Weight [kg]
Steel with welded connection, 110 °C, 10 bar									
10 bar 110 °C	A 60.3 HC	8251105	60.3	25	132	810	153	260	23,0
	A 76.1 HC	8251115	76.1	40	132	810	163	260	23,0
	A 88.9 HC	8251125	88.9	54	206	965	159	370	36,0
	A 114.3 HC	8251135	114.3	94	206	965	169	370	37,0
	A 139.7 HC	8251145	139.7	144	354	1,225	214	525	85,0
	A 168.3 HC	8251155	168.3	216	354	1,225	229	525	86,0
	A 219.1 HC	8251165	219.1	376	409	1,495	284	650	129,0
	A 273.0 HC	8251175	273	576	480	1,609	351	750	175,0
	A 323.9 HC	8251185	323.9	810	634	2,225	406	850	340,0
Steel with flange connection, 110 °C, 10 bar									
10 bar 110 °C	A 50 HC	8251305	DN 50 / PN 16	25	132	810	153	350	23,0
	A 65 HC	8251315	DN 65 / PN 16	40	132	810	163	350	23,0
	A 80 HC	8251325	DN 80 / PN 16	54	206	965	159	470	36,0
	A 100 HC	8251335	DN 100 / PN 16	94	206	965	169	470	22,0
	A 125 HC	8251345	DN 125 / PN 16	144	354	1,225	214	635	85,0
	A 150 HC	8251355	DN 150 / PN 16	216	354	1,225	229	635	86,0
	A 200 HC	8251365	DN 200 / PN 16	376	409	1,495	284	775	90,0
	A 250 HC	8251375	DN 250 / PN 16	576	480	1,609	351	890	175,0
	A 300 HC	8251385	DN 300 / PN 16	810	634	2,225	406	1.005	340,0
	A 350 HC	8251915	DN 350 / PN 16	1,000	650	2,460	501	1.128	293,0
	A 400 HC	8251925	DN 400 / PN 16	1,300	750	2,740	580	1.226	540,0
	A 450 HC	8251945	DN 450 / PN 16	1,700	750	3,030	609	1.330	570,0
	A 500 HC	8251955	DN 500 / PN 16	2,120	1,000	3,310	671	1.430	1.000,0
A 600 HC	8251965	DN 600 / PN 16	3,060	1,200	3,160	832	1.630	2.420,0	

Key advantages

Optimum dirt and sludge separation for enhanced operational reliability and efficiency

- Reliably removes circulating free dirt and sludge particles measuring up to 5 micrometres without energy consumption
- Ensures that components such as heat generators, thermostatic valves and pumps function perfectly and minimises the risk of defects and breakdowns in the long term
- Particle separation improves heating and cooling performance
- Fully automatic continuous operation, generates only a minimal, constant pressure drop
- Excellent separation of ferromagnetic impurities, such as magnetite, thanks to high-performance Exferro Easy Clip clip-on magnet for brass separators (included in the scope of supply) and Exferro magnetic insert for steel separators (optional)

Less maintenance compared to conventional dirt traps

- Fast online maintenance and desludging without having to interrupt operation
- No shut-off valves or bypasses needed
- No clogging, unlike filters. Instead: permanently free opening for the water to flow through

Broad product portfolio for any and all applications

- Full range of operating pressures, temperatures and materials
- Special designs for higher flow rates, operating pressures and operating temperatures available on request



* 5 years guarantee for brass separators from date of manufacture.
Please consider the guarantee conditions and guidelines at www.reflex-winkelmann.com/en

Construction, function and installation

Exdirt construction

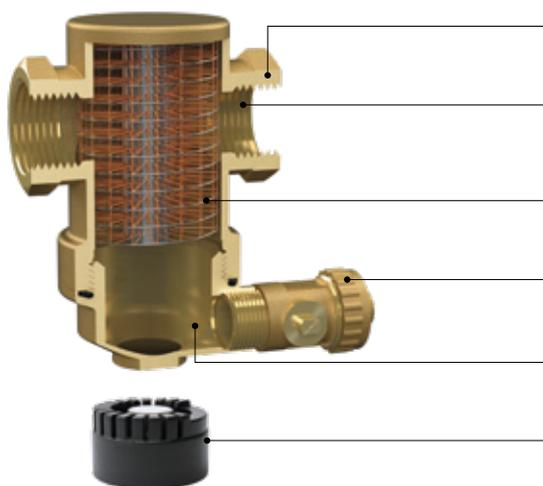

Numerous connection options: Threaded, welded and flange connections from FT ¾ to DN 600.

Flow is not hindered by sludge.

The mesh tube design that forms the core of the process has been tried and trusted for decades.

Drain valve for quick cleaning without interrupting operation.

Large sludge trap capacity extends cleaning intervals.

Exferro Easy Clip high-performance magnet for Exdirt (brass). The strength of the magnetic field exerts maximum impact on the fluid in the separator, enabling the optimum separation of ferromagnetic dirt particles, such as magnetite.

Brass type

Exdirt function principle



1. The flow is fed through an area with a larger cross section than the connection dimensions to reduce the flow speed. The dirt particles sink to the bottom as a result of the extended retention time in the separator and the force of gravity.
2. The flow element potentiates the separation effect. The impulses exerted on the dirt and sludge particles in this way promote their natural settling movement, resulting in separation of freely circulating particles down to a minimum of 5 µm.
3. Depending on the flow rate, density and volume, the natural settling of some of the sludge particles is supported, and the particles are guided to the lower area of the housing.
4. The deposits collected here can be discharged from the separator via the desludging tap without interrupting operation.

Steel type

Exdirt installation

Installation location

In heating and cooling systems in the return flow upstream of the heat generators, heat exchangers, bypasses, sensitive consumers and circulating pumps that require protection.

- The maintenance interval depends on the amount of dirt transported in the system. We recommend initial inspection after four weeks and a documented service at least once a year.

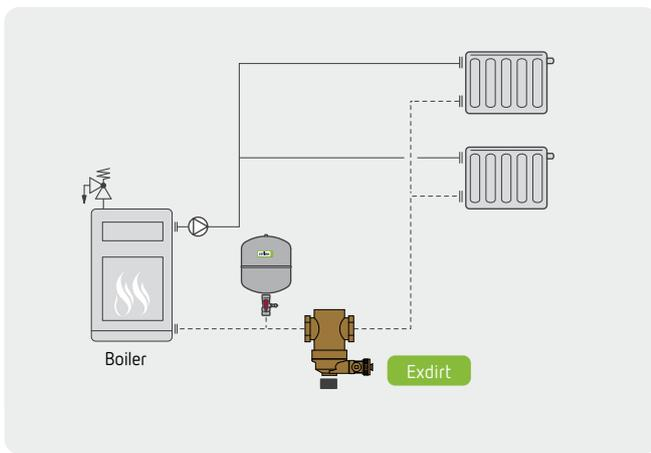

Exdirt (brass) in a heating system

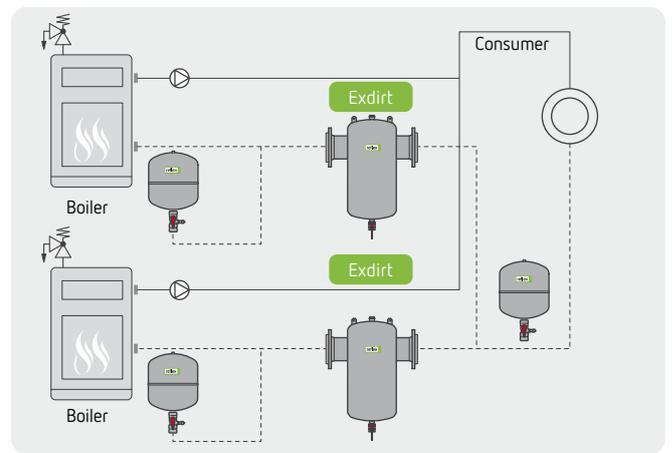

Exdirt (steel) in a heating system

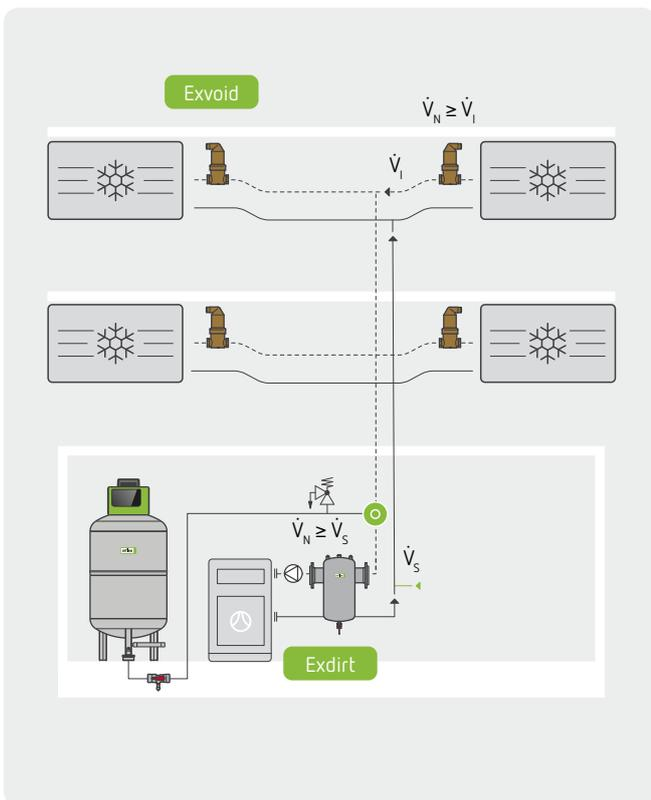

Central sludge separation with Exdirt dirt and sludge separator in a cooling system

- Decentralised separation of micro-bubbles (Exvoid A) in conjunction with centralised separation of dirt particles by an Exdirt D in the main volume flow \dot{V}_S upstream of the cooler.
- Both separators are located in the return flow for "cooling" applications.
- A decentralised separator layout like this can make sense in an open system exposed to increased risk of corrosion. In this case, brass would be the material of choice (brass separators are available up to DN 50).
- Alternatively, the Exdirt dirt and sludge separator in this configuration could be replaced with an Extwin combined dirt and micro-bubble separator. In all configurations, accessibility of the installed parts must be assured and the greater operating workload considered.

Exdirt product range

Exdirt Dirt and sludge separator

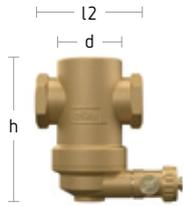

Exdirt horizontal



Exdirt vertical



Exdirt (brass) dirt and sludge separator, horizontal



Exdirt (brass) dirt and sludge separator, vertical



Technical features

- Connection diameter: A22–2" (DN 20–DN 50)
- Flow rate: 1.25–7.5 m³/h (at v ≈ 1.0 m/s)
- Exiso heat insulation: A22–2" (DN 20–DN 50)
- Brass housing
- Application: up to 110 °C and 10 bar, further pressure ratings and temperatures on request
- Installation position: horizontal, vertical
- Removes circulating free dirt and sludge particles of up to 5 µm

	Type	Art. No.	DG	PQ [pce]	Connection c	V _{max} [m ³ /h]	Ø d [mm]	Height h [mm]	Length l2 [mm]	Weight [kg]
Plug-in magnet, Brass, Horizontal										
10 bar 110 °C	D 22 M	9256600	0082	12	22 mm	1.2	63	122	106	1.00
	D ¾ M	9256610	0082	12	IG ¾"	1.2	63	122	85	1.00
	D 1 M	9256620	0082	12	IG 1"	2.0	63	139	88	1.20
	D 1 ¼ M	9256630	0082	8	IG 1 ¼"	3.7	63	159	88	1.30
	D 1 ½ M	9256640	0082	8	IG 1 ½"	5.0	63	193	88	1.50
	D 2 M	9256650	0082	1	IG 2"	7.5	100	234	132	3.02
Plug-in magnet, Brass, Vertical										
10 bar 110 °C	D 22 VM	9256700	0082	8	22 mm	1.2	63	173	104	1.90
	D ¾ VM	9256710	0082	8	IG ¾"	1.2	63	163	84	1.80
	D 1 VM	9256720	0082	8	IG 1"	2.0	63	163	84	1.80
Brass, Horizontal										
10 bar 110 °C	D 22	9252000	0082	12	22 mm	1.2	63	103	106	0.92
	D ¾	9252010	0082	12	IG ¾"	1.2	63	103	85	1.00
	D 1	9252020	0082	12	IG 1"	2.0	63	120	88	1.20
	D 1 ¼	9252030	0082	8	IG 1 ¼"	3.7	63	140	88	1.12
	D 1 ½	9252040	0082	8	IG 1 ½"	5.0	63	174	88	1.32
	D 2	9252050	0082	1	IG 2"	7.5	100	215	132	3.10
Brass, Vertical										
10 bar 110 °C	D 22V	9252500	0082	8	22 mm	1.2	63	154	104	1.52
	D ¾V	9252510	0082	8	IG ¾"	1.2	63	144	84	1.80
	D 1V	9252520	0082	8	IG 1"	2.0	63	144	84	1.61

Exdirt Twist Dirt and sludge separator



Twist separator connections are infinitely rotatable 360° (non-ratcheting), making them suitable for a wide range of different installation positions. The connection can be rotated by hand.



Exdirt Twist

Technical features

- Infinitely rotatable (non-ratcheting) brass separator for installation in any position
- Connection diameter: A 22–1 ½" (DN 20–DN 40)
- Volumetric flow: 1,25–5,0 m³/h (bei v ≈ 1,0 m/s)
- Exiso heat insulation: A 22–1 ½" (DN 20–DN 40)
- Brass casing
- Area of application: up to 110 °C
- Installation position: 360° infinitely rotatable (non-ratcheting)
- Water/glycol mixture up to a mixing ratio of 50 :50 (at least 25%)

	Type	Art. No.	DG	PQ [pce]	Connection c	V _{max} [m³/h]	Ø d [mm]	Height h [mm]	Length l2 [mm]	Weight [kg]
Twist, Plug-in magnet, Brass, Rotatable										
10 bar 110 °C	DT 22 M	9257300	0092	8	22 mm	1.2	63	176	109	1.98
	DT 28 M	9257310	0092	8	28 mm	2.0	63	177	111	2.10
	DT ¾ M	9257320	0092	8	IG ¾"	1.2	63	164	85	1.83
	DT 1 M	9257330	0092	8	IG 1"	2.0	63	171	100	1.97
	DT 1 ¼ M	9257340	0092	6	IG 1 ¼"	3.8	63	221	100	2.48
	DT 1 ½ M	9257350	0092	6	IG 1 ½"	5.0	63	221	100	2.32

The Exiso heat insulation for the above separators can be found under accessories on page 35.



Exferro EasyClip

All Exdirt and Extwin brass separators are fitted with a high-performance Exferro Easy Clip magnet. The axially aligned neodymium magnet can hold 14.4 kg and is simply clipped on from below.

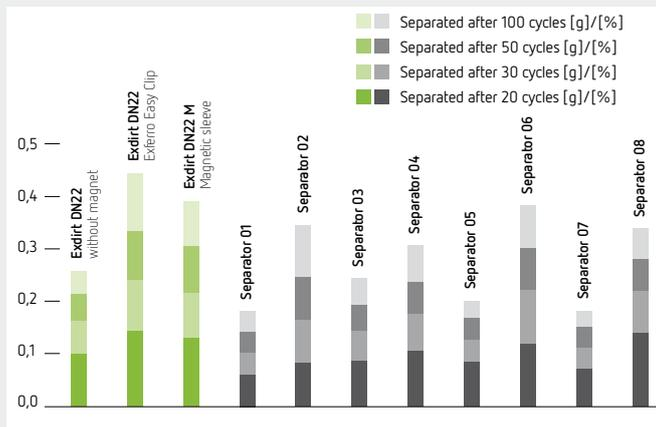

Field line curve of Exferro Easy Clip

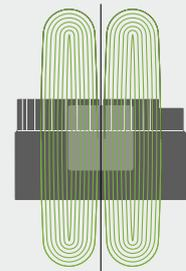

The strength of the magnetic field exerts maximum impact on the fluid in the separator, enabling the optimum separation of ferromagnetic dirt particles.

Exdirt Dirt and sludge separator

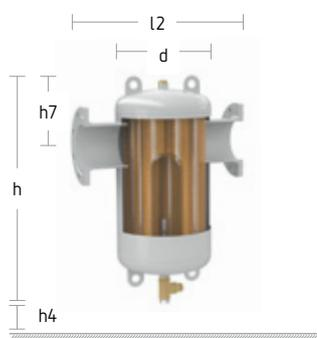

Exdirt (steel) flange connection

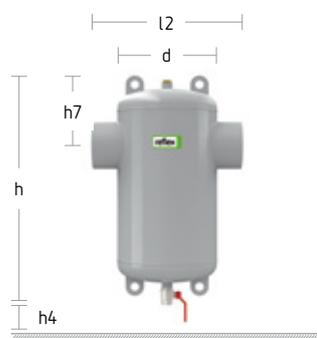

Exdirt (steel) welded connection

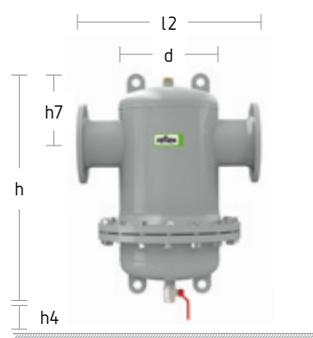
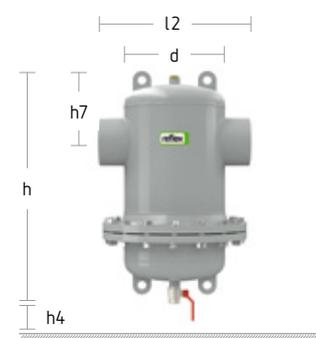
Exdirt (steel) flange connection
with service flangeExdirt (steel) welded connection
with service flange

Technical features

- Types with service flange
- Connection: DN 50–DN 600
- Exiso heat insulation: DN 50–DN 150 for model without service flange
- Optional: High-performance Exferro magnetic insert for optimum efficiency when separating ferromagnetic dirt particles such as magnetite (see Accessories, page 30)
- Application: up to 110 °C and 10 bar, further pressure ratings and temperatures on request

	Type	Art. No.	DG	Connection c	V_{max} [m ³ /h]	\emptyset d [mm]	Height h [mm]	Height h7 [mm]	Height h4 [mm]	Length L2 [mm]	Weight [kg]
Painted steel, Flange											
10 bar 110 °C	D 50	8252300	0083	DN50/PN16	12.5	132	521	165	370	350	9.00
	D 65	8252310	0083	DN65/PN16	20.0	132	521	175	370	350	10.00
	D 80	8252320	0083	DN80/PN16	27.0	206	636	170	370	470	16.00
	D 100	8252330	0083	DN100/PN16	47.0	206	636	180	370	475	19.00
	D 125	8252340	0083	DN125/PN16	72.0	354	811	225	430	635	35.00
	D 150	8252350	0083	DN150/PN16	108.0	354	811	240	430	635	39.00
	D 200	8252360	0083	DN200/PN16	180.0	409	1,021	295	430	775	65.00
	D 250	8252370	0083	DN250/PN16	288.0	480	1,324	385	500	890	108.00
D 300	8252380	0083	DN300/PN16	405.0	634	1,535	413	500	1,005	156.00	
Painted steel, Flange, Service flange											
10 bar 110 °C	D 50 R	8252400	0083	DN50/PN16	12.5	132	521	165	370	350	18.00
	D 65 R	8252410	0083	DN65/PN16	20.0	132	521	175	370	350	19.00
	D 80 R	8252420	0083	DN80/PN16	27.0	206	636	170	430	470	43.00
	D 100 R	8252430	0083	DN100/PN16	47.0	206	636	180	430	475	51.00
	D 125 R	8252440	0083	DN125/PN16	72.0	354	811	225	550	635	89.00
	D 150 R	8252450	0083	DN150/PN16	108.0	354	811	240	550	635	94.00
	D 200 R	8252460	0083	DN200/PN16	180.0	409	1,021	295	650	775	121.00
	D 250 R	8252470	0083	DN250/PN16	288.0	480	1,324	358	850	890	255.00
D 300 R	8252480	0083	DN300/PN16	405.0	634	1,535	413	1,000	1,005	390.00	

Other designs (higher operating temperatures, higher operating pressures) are available upon request.

Exdirt Dirt and sludge separator

	Type	Art. No.	DG	Connection c	V _{max} [m ³ /h]	Ø d [mm]	Height h [mm]	Height h7 [mm]	Height h4 [mm]	Length l2 [mm]	Weight [kg]
Painted steel, Welded connector											
10 bar 110 °C	D 60.3	8252100	0083	60.3	12.5	132	521	165	370	260	3.00
	D 76.1	8252110	0083	76.1	20.0	132	521	175	370	260	3.00
	D 88.9	8252120	0083	88.9	27.0	206	636	170	370	370	9.00
	D 114.3	8252130	0083	114.3	47.0	206	636	180	370	370	9.00
	D 139.7	8252140	0083	139.7	72.0	354	811	225	430	525	22.00
	D 168.3	8252150	0083	168.3	108.0	354	811	240	430	525	24.00
	D 219.1	8252160	0083	219.1	180.0	409	1,021	295	430	650	44.00
	D 273.0	8252170	0083	273.0	288.0	480	1,324	358	500	750	70.00
	D 323.9	8252180	0083	323.9	405.0	634	1,535	413	500	850	112.00
Painted steel, Welded connector, Service flange											
10 bar 110 °C	D 60.3 R	8252200	0083	60.3	12.5	132	521	165	370	260	16.00
	D 76.1 R	8252210	0083	76.1	20.0	132	521	175	370	260	23.00
	D 88.9 R	8252220	0083	88.9	27.0	206	636	170	430	370	32.00
	D 114.3 R	8252230	0083	114.3	47.0	206	636	180	430	370	37.00
	D 139.7 R	8252240	0083	139.7	72.0	354	811	225	550	525	85.00
	D 168.3 R	8252250	0083	168.3	108.0	354	811	240	550	525	78.00
	D 219.1 R	8252260	0083	219.1	180.0	409	1,021	295	650	650	101.00
	D 273.0 R	8252270	0083	273.0	288.0	480	1,324	358	850	750	158.00
	D 323.9 R	8252280	0083	323.9	405.0	634	1,535	413	1,000	850	330.00

Other designs (higher operating temperatures, higher operating pressures) are available upon request.

Exdirt Hi-Cap Dirt and sludge separator

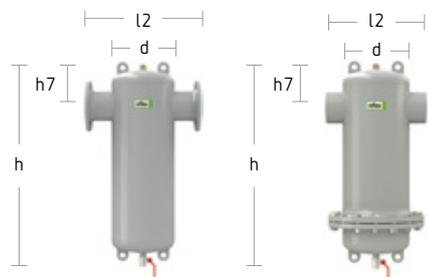

Exdirt (steel) Hi-Cap
flange connection

Exdirt (steel) Hi-Cap
welded connection

Technical
features

- For high flow rates and high flow speeds up to 3 m/s
- Connection: DN 50 – DN 600
- Flow rate: 25 – 3,060 m³/h
- Steel housing
- Application: up to 110 °C and 10 bar, further pressure ratings and temperatures on request

	Type	Art. No.	Connection c	V _{max} [m ³ /h]	Ø d [mm]	Height h [mm]	Height h7 [mm]	Length L2 [mm]	Weight [kg]
Steel with welded connection, 110 °C, 10 bar									
10 bar 110 °C	D 60.3 HC	8252105	60,3	25	132	706	165	260	5,0
	D 76.1 HC	8252115	76,1	40	132	706	175	260	23,0
	D 88.9 HC	8252125	88,9	54	206	861	170	370	36,0
	D 114.3 HC	8252135	114,3	94	206	861	180	370	37,0
	D 139.7 HC	8252145	139,7	144	354	1.121	225	525	85,0
	D 168.3 HC	8252155	168,3	216	354	1.121	240	525	86,0
	D 219.1 HC	8252165	219,1	376	409	1.391	295	650	129,0
	D 273.0 HC	8252175	273	576	480	1.532	358	750	175,0
	D 323.9 HC	8252185	323,9	810	634	2.148	413	850	340,0
Steel with welded connection, 110 °C, 10 bar, service flange									
10 bar 110 °C	D 60.3 R-HC	8252205	60,3	25	132	706	165	260	23,0
	D 76.1 R-HC	8252215	76,1	40	132	706	175	260	23,0
	D 88.9 R-HC	8252225	88,9	54	206	861	170	370	36,0
	D 114.3 R-HC	8252235	114,3	94	206	861	180	370	37,0
	D 139.7 R-HC	8252245	139,7	144	354	1.121	225	525	85,0
	D 168.3 R-HC	8252255	168,3	216	354	1.121	240	525	86,0
	D 219.1 R-HC	8252265	219,1	376	409	1.391	295	650	129,0
	D 273.0 R-HC	8252275	273	576	480	1.532	358	750	260,0
	D 323.9 R-HC	8252285	323,9	810	634	2.148	413	850	460,0
Steel with flange connection, 110 °C, 10 bar									
10 bar 110 °C	D 50 HC	8252305	DN 50 / PN 16	25	132	706	165	350	28,0
	D 65 HC	8252315	DN 65 / PN 16	40	132	706	175	350	29,0
	D 80 HC	8252325	DN 80 / PN 16	54	206	861	170	470	18,0
	D 100 HC	8252335	DN 100 / PN 16	94	206	861	180	470	46,0
	D 125 HC	8252345	DN 125 / PN 16	144	354	1.121	225	635	98,0
	D 150 HC	8252355	DN 150 / PN 16	216	354	1.121	240	635	100,0
	D 200 HC	8252365	DN 200 / PN 16	376	409	1.391	295	775	75,0
	D 250 HC	8252375	DN 250 / PN 16	576	480	1.532	358	890	119,0
	D 300 HC	8252385	DN 300 / PN 16	810	634	2.148	413	1.005	218,0
	D 350 HC	8252915	DN 350 / PN 16	1.000	650	2.400	509	1.128	270,0
	D 400 HC	8259325	DN 400 / PN 16	1.300	750	2.680	588	1.226	on request
	D 450 HC	8252945	DN 450 / PN 16	1.700	750	2.970	617	1.330	on request
	D 500 HC	8252955	DN 500 / PN 16	2.120	1.000	3.100	679	1.430	on request
	D 600 HC	8252965	DN 600 / PN 16	3.060	1.200	3.250	840	1.630	on request
Steel with flange connection, 110 °C, 10 bar, service flange									
10 bar 110 °C	D 50 R-HC	8252405	DN 50 / PN 16	25	132	706	165	350	28,0
	D 65 R-HC	8252415	DN 65 / PN 16	40	132	706	175	350	29,0
	D 80 R-HC	8252425	DN 80 / PN 16	54	206	861	170	470	44,0
	D 100 R-HC	8252435	DN 100 / PN 16	94	206	861	180	470	46,0
	D 125 R-HC	8252445	DN 125 / PN 16	144	354	1.121	225	635	98,0
	D 150 R-HC	8252455	DN 150 / PN 16	216	354	1.121	240	635	100,0
	D 200 R-HC	8252465	DN 200 / PN 16	376	409	1.391	295	775	140,0
	D 250 R-HC	8252475	DN 250 / PN 16	576	480	1.532	358	890	246,0
	D 300 R-HC	8252485	DN 300 / PN 16	810	634	2.148	413	1.005	510,0
	D 350 R-HC	8252917	DN 350 / PN 16	1.000	650	2.400	509	1.128	on request
	D 400 R-HC	8252927	DN 400 / PN 16	1.300	750	2.680	588	1.226	on request
	D 450 R-HC	8252947	DN 450 / PN 16	1.700	750	2.970	617	1.330	on request
	D 500 R-HC	8252957	DN 500 / PN 16	2.120	1.000	3.100	679	1.430	on request
	D 600 R-HC	8252967	DN 600 / PN 16	3.060	1.200	3.250	840	1.630	on request



Exdirt V Dirt and sludge separator for vertical installation

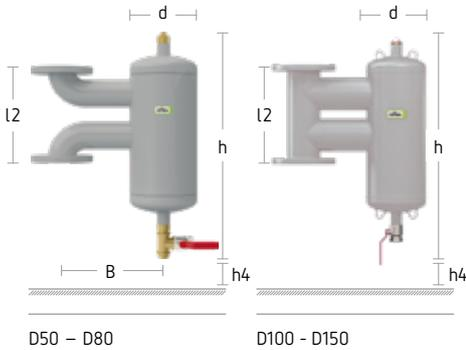

Technical features

- Standard installation length F1 in acc. with DIN EN 558:2017-05
- Desludging and venting connection: 1"
- Water/glycol mixture up to a mixing ratio of 50/50 (25% minimum)
- Removal of particles down to 5 µm in size
- Insulation must be supplied by the installer
- Optional: High-performance Exferro magnetic insert (see Accessories, p. 30)
- Further pressure ratings and temperatures on request

Functionality

- The flow is fed through an area with a larger cross section than the connection dimensions to reduce the flow speed. The dirt particles sink to the bottom as a result of the extended retention time in the separator and the force of gravity.
- The Flowpac flow element potentiates the separation effect in the steady-flow chamber. The impulses exerted on the dirt and sludge particles in this way promote their natural settling movement. This is how freely circulating particles down to a minimum of 5 µm are released.
- Some of the recorded sludge particles are supported in their natural settling movement and guided to the lower area of the housing depending on the flow rate, density and volume.
- The deposits collected here can be discharged from the separator via the de-sludging tap without interrupting operation.

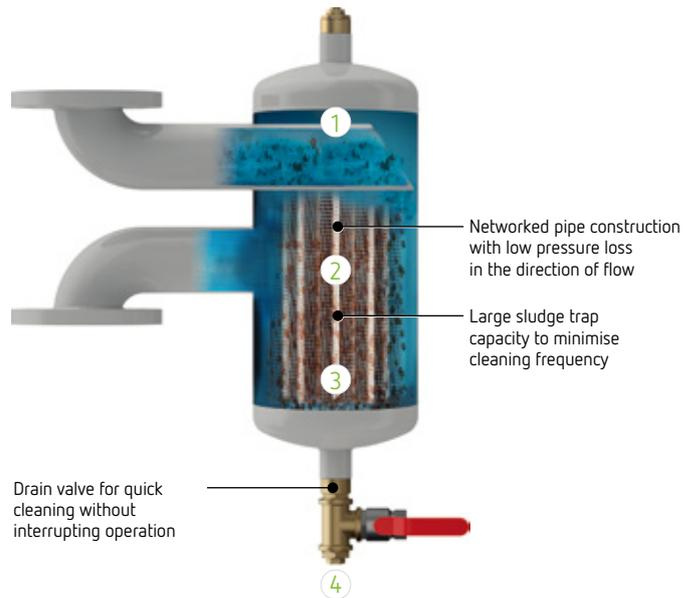

Replacing a dirt trap

Thanks to its standard F1 installation length in accordance with EN 558:2017-05, the Exdirt V can be installed simply and cost-effectively in place of existing dirt traps. Exdirt V functions without any filter elements. The benefits: instead of clogging, permanently free opening for the facility water to flow through; cleaning is possible without having to interrupt operation.

* All installed apparatus must be checked with regard to the new technology to be used according to individual system circumstances prior to replacing a dirt trap with an Exdirt V.



Exdirt V Dirt and sludge separator for vertical installation

	Type	Art. No.	DG	Connection c	V _{max} [m ³ /h]	Ø d [mm]	Height h [mm]	Height h4 [mm]	Length l2 [mm]	Length l3 [mm]	Weight [kg]
Painted steel, Flange											
6 bar 110 °C	D 50V F1	8259501	0083	DN50/PN6	12.5	206	569	370	230	296	13.70
	D 65V F1	8259511	0083	DN65/PN6	20.0	206	617	370	290	306	15.80
	D 80V F1	8259521	0083	DN80/PN6	27.0	206	667	370	310	313	19.70
	D 100V F1	8259531	0083	DN100/PN6	47.0	206	717	370	350	323	24.40
	D 125V F1	8259541	0083	DN125/PN6	72.0	354	968	430	400	412	59.10
	D 150V F1	8259551	0083	DN150/PN6	108.0	354	1,018	430	480	430	67.20
10 bar 110 °C	D 50V F1	8259500	0083	DN50/PN16	12.5	206	569	370	230	296	16.10
	D 65V F1	8259510	0083	DN65/PN16	20.0	206	617	370	290	306	18.30
	D 80V F1	8259520	0083	DN80/PN16	27.0	206	667	370	310	313	21.70
	D 100V F1	8259530	0083	DN100/PN16	47.0	206	717	370	350	323	26.60
	D 125V F1	8259540	0083	DN125/PN16	72.0	354	968	430	400	412	62.20
	D 150V F1	8259550	0083	DN150/PN16	108.0	354	1,018	430	480	430	71.80

Other designs (higher operating temperatures, higher operating pressures) are available upon request.

Exdirt V pressure loss diagram

Connection	K _{V5} [m ³ /h]	V _{max} [m ³ /h]
DN 50	64.5	12.50
DN 65	109.5	20.00
DN 80	142.7	27.00
DN 100	219.8	47.00
DN 125	316.2	72.00
DN 150	439.1	108.00

Pressure loss calculation for all flow rates

$$\Delta p = \left(\frac{\dot{V}}{K_{V5}} \right)^2 \cdot 1 \text{ bar}; \dot{V} \leq \dot{V}_{\text{max}}$$

Example: Heating circuit 70/55 °C;
Heat generator output 80 kW

1. Volumetric flow calculation

$$\dot{V} = \frac{80 \text{ kW}}{4,2 \text{ kJ} / (\text{kg} \cdot \text{K}) \cdot (70 - 55) \text{ K}} \cdot 3.600 \frac{\text{s}}{\text{h}} \cdot \frac{1 \text{ m}^3}{1.000 \text{ kg}}$$

$$= 4,6 \text{ m}^3/\text{h} \rightarrow \text{Selection based on table: DN 50 with } K_{V5} = 64,5 \text{ m}^3/\text{h}$$

$$\Delta p = \left(\frac{4,6 \text{ m}^3/\text{h}}{64,5 \text{ m}^3/\text{h}} \right)^2 \cdot 1 \text{ bar} = 5,08 \cdot 10^{-3} \text{ bar} \mid \cdot 100 \text{ kPa}/\text{bar}$$

$$= 0,508 \text{ kPa}$$

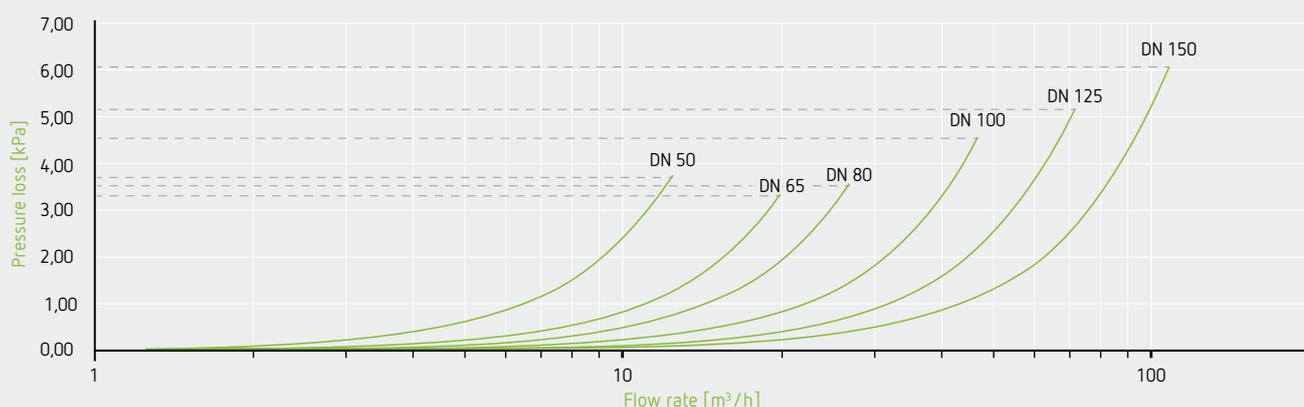

Key advantages

Combines the protective functions of Reflex Exvoid and Exdirt in a single component

- A much cheaper solution compared to the sum of the individual components
- Eliminates circulating air, micro-bubbles, dirt and sludge particles (down to 5 micrometres) for enhanced operational reliability and improved heating and cooling performance
- Assures the flawless functional reliability of heat generators, thermostat valves, etc. over the long term
- Fully automatic continuous operation, generates only a minimal, constant pressure drop
- Types available in brass and steel, depending on the dimensions
- Excellent separation of ferromagnetic impurities, such as magnetite, thanks to high-performance Exferro Easy Clip magnet for brass separators (included in the scope of supply) and Exferro magnetic insert for steel separators (optional)

Quick and easy installation and maintenance

- Fast online maintenance and desludging without having to interrupt operation
- No shut-off valves or bypasses needed

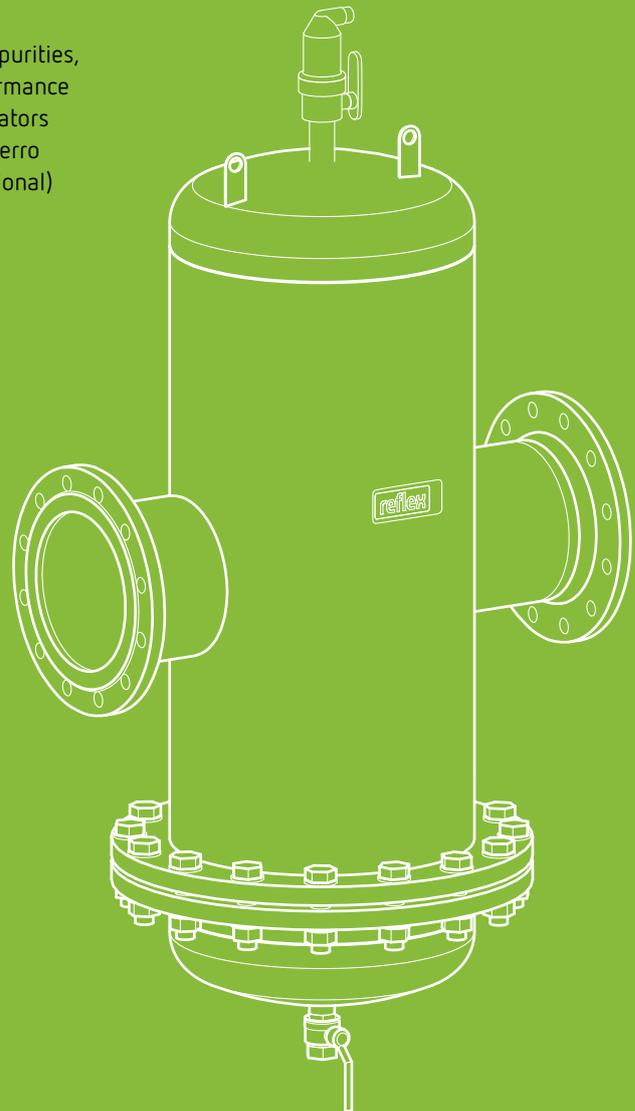

* 5 years guarantee for brass separators from date of manufacture.
Please consider the guarantee conditions and guidelines at www.reflex-winkelmann.com/en

Construction, function and installation

Extwin construction

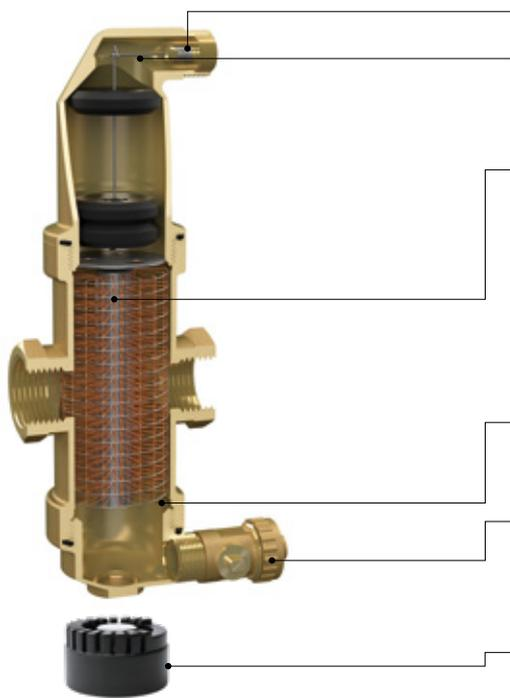

Leakproof venting valve, cannot be shut off.

Special air chamber design: Floating impurities cannot reach the venting valve; high air chamber volume to counter pressure fluctuations

The mesh tube design that forms the core of the process has been tried and trusted for decades. Its pressure loss is extremely low in flow direction but high in transverse direction. As a result, turbulence is greatly reduced and the dirt particles are guided to partly calm areas.

Numerous connection options: Threaded, welded and flange connections from FT 3/4" to DN 600.

Large sludge trap capacity extends cleaning intervals.

Space-saving drain tap. When opened, the accumulated sludge is pressed out quickly and forcefully so that the tap can be closed again immediately. The whole procedure takes just seconds.

High-performance Exferro Easy Clip magnet for Extwin (brass) separates ferromagnetic particles. Extwin (steel) with optional Exferro magnetic insert.

Brass type

Extwin function principle

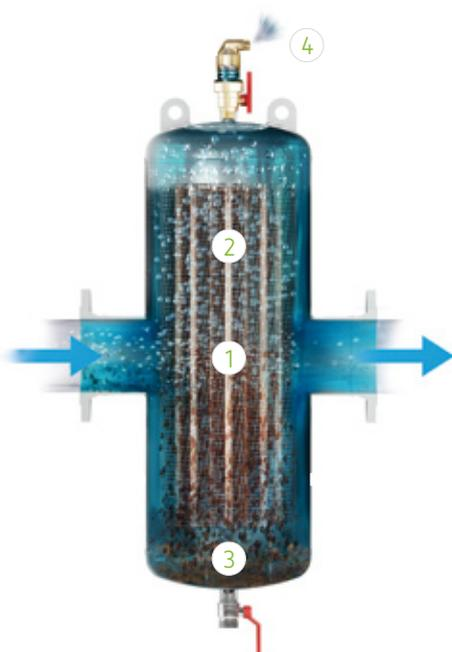

Extwin combines the functional modes of Exvoid and Exdirt

1. The flow is fed through an area with a larger cross section than the connection dimensions to reduce the flow speed.
2. The turbulence caused by the mesh tube excites gas bubbles and heavy solids to move in an indeterminate direction.
3. Depending on the flow rate, density and volume, the natural settling of some of the sludge particles is supported, and the particles are guided to the lower area of the housing.
4. At the same time, micro-bubbles that are moving freely and have settled on the Flowpac mesh tube join, rise and are discharged from the system through the upper vent.

Steel type

Installation Extwin

Installation location

Depending on functional prioritisation: If micro-bubble separation is the top priority in heating systems, Extwin must be installed in the delivery flow downstream of heat generators and mixing valves and upstream of the circulation pump. In cooling systems, it must be installed upstream of the cooling machine in the return flow or combined with a heat exchanger.

If dirt and sludge separation is the top priority, Extwin must be installed in the return flow. Its use is recommended in facilities with low static heights (facility heights up to 10 m). To ensure effective sludge and micro-bubble separation, we recommend the use of both Exvoid and Exdirt.

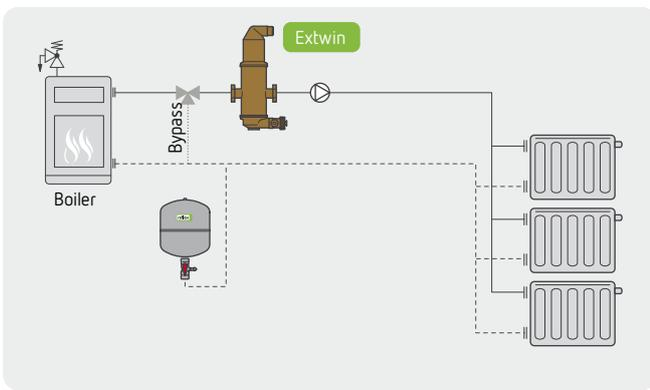

Extwin (brass) in a heating system where micro-bubble separation is the top priority

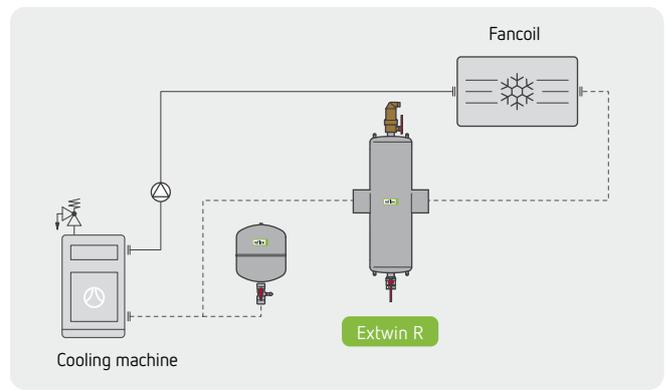

Extwin (steel) in a cooling system where the top priority is dirt and sludge separation combined with micro-bubble separation.

Extwin product range

Extwin Combined microbubble, dirt and sludge separator



Extwin horizontal

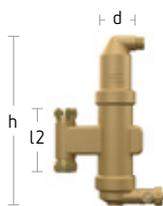

Extwin vertical

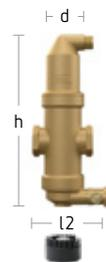

Extwin horizontal, with magnet



Extwin vertical, with magnet



Technical features

- Connection options: Thread and clamping ring
- Connection diameter A22–1" (DN 20–DN 25)
- Flow rate: 1.25–2.0 m³/h (at v ≈ 1.0 m/s)
- Installation position: horizontal, vertical
- High-performance **Exferro Easy Clip** magnet for separating ferromagnetic particles is included in the scope of supply (see page 20 for more details).

Extwin Combined microbubble, dirt and sludge separator

	Type	Art. No.	DG	PQ [pce]	Connection c	V _{max} [m ³ /h]	Ø d [mm]	Height h [mm]	Length l2 [mm]	Weight [kg]
Plug-in magnet, Brass, Horizontal										
10 bar 110 °C	TW 22 M	9257600	0082	6	22 mm	1.2	63	275	106	1.80
	TW 1 M	9257610	0082	6	IG 1"	2.0	63	275	88	1.70
Plug-in magnet, Brass, Vertical										
10 bar 110 °C	TW 22V-M	9257700	0082	6	22 mm	1.2	63	285	98	1.90
Brass, Horizontal										
10 bar 110 °C	TW 22	9253000	0082	6	22 mm	1.2	63	256	106	1.80
	TW 1	9253010	0082	6	IG 1"	2.0	63	259	88	1.63
Brass, Vertical										
10 bar 110 °C	TW 22V	9253500	0082	6	22 mm	1.2	65	266	98	2.10

Extwin Twist Combined microbubble, dirt and sludge separator



Twist separator connections are infinitely rotatable 360° (non-ratcheting), making them suitable for a wide range of different installation positions. The connection can be rotated by hand.



Extwin Twist with magnet

Technical features

- Infinitely rotatable (non-ratcheting) brass separator for installation in any position
- Connection diameter: A 22–1 ½" (DN 20–DN 40)
- Volumetric flow: 1,25–5,0 m³/h (bei v ≈ 1,0 m/s)
- Exiso heat insulation: A 22–1 ½" (DN 20–DN 40)
- Brass casing
- Area of application: up to 110 °C
- Installation position: 360° infinitely rotatable (non-ratcheting)
- Water/glycol mixture up to a mixing ratio of 50 :50 (at least 25%)

	Type	Art. No.	DG	PQ [pce]	Connection c	V _{max} [m ³ /h]	Ø d [mm]	Height h [mm]	Length l2 [mm]	Weight [kg]
Twist, Plug-in magnet, Brass, Rotatable										
10 bar 110 °C	TWT 22 M	9257100	0092	4	22 mm	1.2	63	285	109	2.54
	TWT 28 M	9257110	0092	4	28 mm	2.0	63	285	111	2.67
	TWT ¾ M	9257120	0092	4	IG ¾"	1.2	63	285	85	2.40
	TWT 1 M	9257130	0092	4	IG 1"	2.0	63	285	100	2.50
	TWT 1 ¼ M	9257140	0092	4	IG 1 ¼"	3.8	63	285	100	3.03
	TWT 1 ½ M	9257150	0092	4	IG 1 ½"	5.0	63	285	100	2.87

The Exiso heat insulation for the above separators can be found under accessories on page 35.

Extwin Combined microbubble, dirt and sludge separator

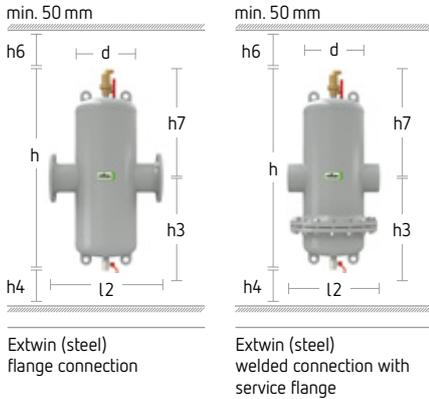

Technical features

- The type with service flange has a removable bottom part for easier maintenance
- Connection: DN 50–DN 300
- Flow rate: 12.5–405 m³/h
- Application: up to 110 °C and 10 bar, further pressure ratings and temperatures on request
- Heat insulation available on request

	Type	Art. No.	DG	Connection c	V _{max} [m ³ /h]	∅ d [mm]	Height h [mm]	Height h3 [mm]	Height h7 [mm]	Height h6 [mm]	Height h4 [mm]	Length l2 [mm]	Weight [kg]
Painted steel, Flange													
10 bar 110 °C	TW 50	8253300	0083	DN50/PN16	12.5	132	785	450	335	50	370	350	10.00
	TW 65	8253310	0083	DN65/PN16	20.0	132	785	450	335	50	370	350	10.00
	TW 80	8253320	0083	DN80/PN16	27.0	206	940	527	413	50	370	470	18.00
	TW 100	8253330	0083	DN100/PN16	47.0	206	940	527	413	50	370	470	24.00
	TW 125	8253340	0083	DN125/PN16	72.0	354	1,200	658	542	50	430	635	41.00
	TW 150	8253350	0083	DN150/PN16	108.0	354	1,200	658	542	50	430	635	46.00
	TW 200	8253360	0083	DN200/PN16	180.0	409	1,470	792	678	50	430	775	79.00
	TW 250	8253370	0083	DN250/PN16	288.0	480	1,916	1,001	915	50	500	890	156.00
TW 300	8253380	0083	DN300/PN16	405.0	634	2,237	1,161	1,076	50	500	1,005	325.00	
Painted steel, Flange, Service flange													
10 bar 110 °C	TW 50 R	8253400	0083	DN50/PN16	12.5	132	785	450	335	50	370	350	18.00
	TW 65 R	8253410	0083	DN65/PN16	20.0	132	785	450	335	50	370	350	19.00
	TW 80 R	8253420	0083	DN80/PN16	27.0	206	940	527	413	50	550	470	43.00
	TW 100 R	8253430	0083	DN100/PN16	47.0	206	940	527	413	50	550	470	51.00
	TW 125 R	8253440	0083	DN125/PN16	72.0	354	1,200	658	542	50	750	635	89.00
	TW 150 R	8253450	0083	DN150/PN16	108.0	354	1,200	658	542	50	750	635	94.00
	TW 200 R	8253460	0083	DN200/PN16	180.0	409	1,470	792	678	50	1,000	775	138.00
	TW 250 R	8253470	0083	DN250/PN16	288.0	480	1,916	1,001	915	50	1,350	890	355.00
TW 300 R	8253480	0083	DN300/PN16	405.0	634	2,237	1,161	1,076	50	1,850	1,005	500.00	
Painted steel, Welded connector													
10 bar 110 °C	TW 60.3	8253100	0083	60.3	12.5	132	785	450	335	50	370	260	4.00
	TW 76.1	8253110	0083	76.1	20.0	132	785	450	335	50	370	260	5.00
	TW 88.9	8253120	0083	88.9	27.0	206	940	527	413	50	370	370	12.00
	TW 114.3	8253130	0083	114.3	47.0	206	940	527	413	50	370	370	14.00
	TW 139.7	8253140	0083	139.7	72.0	354	1,200	658	542	50	430	525	34.00
	TW 168.3	8253150	0083	168.3	108.0	354	1,200	658	542	50	430	525	31.00
	TW 219.1	8253160	0083	219.1	180.0	409	1,470	792	678	50	430	650	113.00
	TW 273.0	8253170	0083	273.0	288.0	480	1,916	1,001	915	50	500	750	215.00
TW 323.9	8253180	0083	323.9	405.0	634	2,237	1,161	1,076	50	500	850	265.00	
Painted steel, Welded connector, Service flange													
10 bar 110 °C	TW 60.3 R	8253200	0083	60.3	12.5	132	785	450	335	50	370	260	13.00
	TW 76.1 R	8253210	0083	76.1	20.0	132	785	450	335	50	370	260	13.00
	TW 88.9 R	8253220	0083	88.9	27.0	206	940	527	413	50	550	370	46.00
	TW 114.3 R	8253230	0083	114.3	47.0	206	940	527	413	50	550	370	36.00
	TW 139.7 R	8253240	0083	139.7	72.0	354	1,200	658	542	50	750	525	102.00
	TW 168.3 R	8253250	0083	168.3	108.0	354	1,200	658	542	50	750	525	78.00
	TW 219.1 R	8253260	0083	219.1	180.0	409	1,470	792	678	50	1,000	650	182.00
	TW 273.0 R	8253270	0083	273.0	288.0	480	1,916	1,001	915	50	1,350	750	180.00
TW 323.9 R	8253280	0083	323.9	405.0	634	2,237	1,161	1,076	50	1,850	850	450.00	

Other designs (higher operating temperatures, higher operating pressures) are available upon request.

Extwin Hi-Cap Combined microbubble, dirt and sludge separator

min. 50 mm

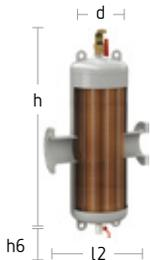

Extwin (steel) Hi-Cap flange connection

min. 50 mm



Extwin (steel) Hi-Cap welded connection

Technical features

- For high flow rates
- The type with service flange has a removable bottom part for easier maintenance
- Connection: DN 50 – DN 600
- Flow rate: 25-3,000 m³/h
- Steel housing
- Application: up to 110 °C and 10 bar, further pressure ratings and temperatures on request

	Type	Art. No.	Connection c	V _{max} [m ³ /h]	Ø d [mm]	Height h [mm]	Min. maintenance height [mm]	Length l2 [mm]	Weight [kg]
Steel with welded connection, 110 °C, 10 bar									
10 bar 110 °C	TW 60.3 HC	8253105	60,3	25	132	1.050	430	260	23,0
	TW 76.1 HC	8253115	76,1	40	132	1.050	430	260	23,0
	TW 88.9 HC	8253125	88,9	54	206	1.285	430	370	36,0
	TW 114.3 HC	8253135	114,3	94	206	1.285	430	370	37,0
	TW 139.7 HC	8253145	139,7	144	354	1.710	500	525	85,0
	TW 168.3 HC	8253155	168,3	216	354	1.710	500	525	86,0
	TW 219.1 HC	8253165	219,1	376	409	2.035	500	650	129,0
	TW 273 HC	8253175	273	576	480	2.764	600	750	305,0
	TW 323.9 HC	8253185	323,9	810	634	3.330	600	850	430,0
Steel with flange connection, 110 °C, 10 bar									
10 bar 110 °C	TW 50 HC	8253305	DN50/PN16	25	132	1.050	430	350	28,0
	TW 65 HC	8253315	DN65/PN16	40	132	1.050	430	350	29,0
	TW 80 HC	8253325	DN80/PN16	54	206	1.285	430	470	44,0
	TW 100 HC	8253335	DN100/PN16	94	206	1.285	430	470	46,0
	TW 125 HC	8253345	DN125/PN16	144	354	1.710	500	635	98,0
	TW 150 HC	8253355	DN150/PN16	216	354	1.710	500	635	100,0
	TW 200 HC	8253365	DN200/PN16	376	409	2.035	500	775	104,0
	TW 250 HC	8253375	DN250/PN16	576	480	2.764	600	890	156,1
	TW 300 HC	8253385	DN300/PN16	810	634	3.330	600	1.005	480,0
	TW 350 HC	8253915	DN350/PN16	1.000	650	3.600	700	1.128	on request
	TW 400 HC	8253925	DN400/PN16	1.300	750	4.000	700	1.226	on request
	TW 450 HC	8253945	DN450/PN16	1.700	750	4.500	700	1.330	on request
	TW 500 HC	8253955	DN500/PN16	2.120	1.000	4.900	700	1.430	on request
	TW 600 HC	8253965	DN600/PN16	3.060	1.200	5.800	700	1.630	on request
Steel with welded connection, 110 °C, 10 bar, service flange									
10 bar 110 °C	TW 60.3 R-HC	8253205	60,3	25	132	1.050	640	260	23,0
	TW 76.1 R-HC	8253215	76,1	40	132	1.050	640	260	23,0
	TW 88.9 R-HC	8253225	88,9	54	206	1.285	900	370	36,0
	TW 114.3 R-HC	8253235	114,3	94	206	1.285	900	370	37,0
	TW 139.7 R-HC	8253245	139,7	144	354	1.710	1.300	525	85,0
	TW 168.3 R-HC	8253255	168,3	216	354	1.710	1.300	525	86,0
	TW 219.1 R-HC	8253265	219,1	376	409	2.035	1.600	650	129,0
	TW 273 R-HC	8253275	273	576	480	2.764	2.100	750	400,0
	TW 323.9 R-HC	8253285	323,9	810	634	3.330	2.900	850	570,0
Steel with flange connection, 110 °C, 10 bar, service flange									
10 bar 110 °C	TW 50 R-HC	8253405	DN50/PN16	25	132	1.050	640	350	28,0
	TW 65 R-HC	8253415	DN65/PN16	40	132	1.050	640	350	29,0
	TW 80 R-HC	8253425	DN80/PN16	54	206	1.285	900	470	44,0
	TW 100 R-HC	8253435	DN100/PN16	94	206	1.285	900	470	46,0
	TW 125 R-HC	8253445	DN125/PN16	144	354	1.710	1.300	635	98,0
	TW 150 R-HC	8253455	DN150/PN16	216	354	1.710	1.300	635	1.00,0
	TW 200 R-HC	8253465	DN200/PN16	367	409	2.035	1.600	775	1.51,0
	TW 250 R-HC	8253475	DN250/PN16	576	480	2.764	2.100	890	4.35,0
	TW 300 R-HC	8253485	DN300/PN16	810	634	3.330	2.900	1.005	6.20,0
	TW 350 R-HC	8253917	DN350/PN16	1.000	650	3.600	-	1.128	10.90,0
	TW 400 R-HC	8253927	DN400/PN16	1.300	750	4.000	-	1.226	on request
	TW 450 R-HC	8253947	DN450/PN16	1.700	750	4.500	-	1.330	on request
	TW 500 R-HC	8253957	DN500/PN16	2.120	1.000	4.900	-	1.430	on request
	TW 600 R-HC	8253967	DN600/PN16	3.060	1.200	5.800	-	1.630	on request

Accessories and add-on products

Exferro Magnetic insert for Exdirt and Extwin steel separators

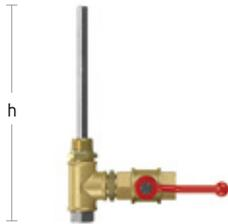

Technical features

- Magnetic insert for Exdirt and Extwin made of steel for collecting ferromagnetic particles during sludge and dirt separation
- Magnetic insert screwed into thermowell / t-piece

Exferro

Type	Art. No.	DG	Weight [kg]
Exferro Magnetic insert for steel Exdirt and Extwin			
Exferro D/TW 50-65 (60.3-76.1)	9258340	0083	0.93
Exferro D/TW 80-100 (88.9-114.3)	9258350	0083	1.40
Exferro D/TW 125-150 (139.7-168.3)	9258360	0083	1.90
Exferro D/TW 200 (219.1)	9258370	0083	2.35
Exferro D/TW 250-300 (273.0-323.9)	9258380	0083	4.70

Exvoid T upper venting part for Exvoid air and micro-bubble separator made of steel with 3-way valve bottom part

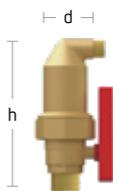

Technical features

- Can be shut off for easy replacement without having to interrupt operation; optional add-on kit for dirt and sludge separators
- Bypass can be used to flush the separator or for filling and emptying

Exvoid T upper venting part

Type	Art. No.	DG	Weight [kg]
Exvoid T			
Exvoid T 1	9255805	0082	1.40

Exiso

Exiso

- Heat insulation for Exvoid A 22–A 1½ and Exdirt D 22–D 2
- Consisting of two dimensionally stable and temperature-resistant, adaptable, friction-locked semi-spheres made of rigid foam, with catch fastener or tightening strap
- Not suitable for vertical separators, separators with service flanges or Extwin

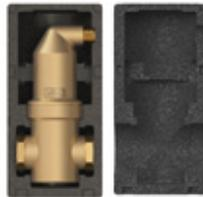

Exiso Twist

- Heat insulation Exiso Twist 22 – 1" and Exiso Twist 1¼ – 1½" on request
- Thermal conductivity 0.035 W/mK (10 °C)



Typ	Art. No.	DG	Weight [kg]
Exiso for horizontal/vertical separators			
Exiso A/D 22 – 1 ½	9254811	0082	0.07
Exiso A/D 2	9254801	0082	0.14
Exiso for turnable separators Ex-Twist			
Exiso AT/DT/TWT 22 – 1	9583510	0082	0.17
Exiso TWT 1 ¼ – 1 ½	9583520	0082	0.17
Exiso AT/DT 1 ¼ – 1 ½	9583530	0082	0.17
Thermal insulation for Exvoid and Exdirt steel models			
Exiso DN 50-65 (60.3 – 76.1)	9254831	0083	0.40
Exiso DN 80-100 (88.9-114.3)	9254841	0083	0.55
Exiso DN 125-150 (139.7-168.3)	9254851	0083	2.20

Expansion trap



Expansion trap 480

Technical features

Expansion traps are installed in the discharge lines of safety valves to separate the water and steam phases. A water drainage line must be connected at the lowest point of the expansion trap to enable leaking heating water to be drained off without danger and under surveillance. The steam discharge line must lead from the highest point of the expansion trap out into the atmosphere.

- For connection to safety valves on heat generators
- For separating water-steam mixtures, as per EN 12828
- Is mounted in the discharge line, right next to the safety valve

10 bar 110 °C	Type	Art. No. Grey	DG	Connection c/c2/c3	Ø d [mm]	Height h [mm]	Weight [kg]
	T 170	8680000	0073	DN50/65/65	206	328	3.15
	T 270	8681000	0073	DN65/80/80	280	400	5.00
	T 380	8682000	0073	DN80/100/100	409	528	10.10
	T 480	8683000	0073	DN125/150/150	480	710	19.45
	T 550	8684000	0073	DN150/200/200	634	896	32.30

Other sizes upon request.

Air separator

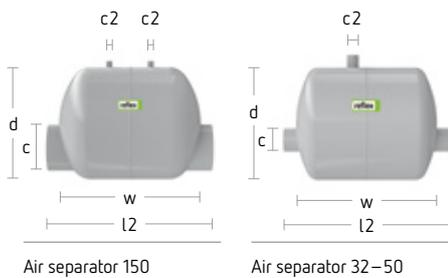

Technical features

Air separators work according to the principle of separation by extreme flow delay. In combination with Exvoid T quick air vents, they are suitable for operational venting of high distribution pipelines and as an air chamber for manual venting during commissioning.

- For separating gas bubbles in liquid circuits
- Especially when static pressure is low
- With welded connection
- Grey coating

	Type	Art. No. Grey	DG	Number of sleeves [pce]	Connection c	Connection c2	Ø d [mm]	Width w [mm]	Length l [mm]	Weight [kg]
10 bar 110 °C	LA 32	8671000	0072	1	DN32/PN16	Rp 3/8"	206	278	300	2.40
	LA 40	8672000	0072	1	DN40/PN16	Rp 3/8"	206	278	300	2.50
	LA 50	8673000	0072	1	DN50/PN16	Rp 3/8"	206	278	300	2.60
	LA 65	8674000	0072	2	DN65/PN16	Rp 3/8"	280	355	395	4.40
	LA 80	8675000	0072	2	DN80/PN16	Rp 3/8"	280	355	395	4.50
	LA 100	8676000	0072	2	DN100/PN16	Rp 3/8"	280	355	395	5.00
	LA 125	8677000	0072	2	DN125/PN16	Rp 3/8"	280	355	395	5.30
	LA 150	8678000	0072	2	DN150/PN16	Rp 3/8"	409	550	590	12.90
	LA 200	8679000	0072	2	DN200/PN16	Rp 3/8"	409	550	590	13.80

Customised solutions



In addition to our standard portfolio, we can also supply customised separators for higher flow rates, operating pressures and operating temperatures on request. We can provide expert, bespoke advice at every step of the way: from project planning and commissioning right through to documentation and maintenance. We have years of experience working in all relevant sectors and all types of buildings.

We can supply separators for

- Higher flow rates
- Higher operating pressures
- Higher operating temperatures
- Special accessories



Example of a real plant for customised sludge collection

Product

Customised Exdirt sludge collector
DN 1,200, 3,000 litres



Example of a real customised Exdirt system

Product

Customised Exdirt dirt and sludge separator D 850 Hi-Cap
with flange connection for PN 10/110 °C

Reflex added value

Our digital services



Reflex Solutions Pro—

Complete product solutions quickly and easily

The next generation of the proven configuration tool allows products from the entire Reflex portfolio to be individually compiled and configured to suit a specific system, irrespective of size—from a single-family home to residential buildings and

industrial premises. Whether a single product or a complete system, just choose the application, then enter the relevant system parameters, Reflex Solutions Pro works out the appropriate configuration quickly and precisely. With one click, you can download the complete documentation such as product data, tender texts and BIM data.

Start designing your configuration now for free:

 rsp.reflex.de/en

Reflex Training — expertise gives us the edge



Close to our headquarters in Ahlen, professional craftsmen, planners and operators gear up to meet the challenges posed by heating and hot water supply in modern building technology. From installation and planning to consulting and technical operation, the Reflex Training Centre and its team aligns its programme to those partners who want to learn more about technology, standards and service from the horse's mouth. Newly acquired expertise is put

into practice, refined and experienced straight away on Reflex systems in a former manor house that has been refurbished to modern-day standards in the German region of Westphalia. Realistic simulations and a comprehensive portfolio of systems help to put the content learned to practical use, skilfully combining theory with practical aspects. The Reflex4Experts training courses are now also available online, for example, as webinars for PC, tablet or smartphone, and include short, interesting learning units on current and exciting topics that can be easily followed in the office, at home or on the road.

More information is available at www.reflex4experts.com/en

Reflex Training Center

+49 2382 7069-9581
seminare@reflex.de



Our performance promise — Reflex After-Sales & Service

Supply technology systems are becoming increasingly complex. This is true for the technology as well for documentation and testing requirements. With Reflex After-Sales & Service, you remain in good hands after your purchase. Our years of expertise specialising in the Reflex product world ensure the full safety and functionality of your system.

- Expertise and many years of experience with all Reflex products
- Qualified personnel with expertise in the latest products and guidelines

- Compliance with statutory regulations and therefore also with liability and warranty provisions
- Systems optimally adapted for maximum efficiency and functionality



You can find more information about all our services at www.reflex-winkelmann.com/int/services-downloads/after-sales-service



Warranty extension to five years

From now on, you can register your system after it has been commissioned by us or by a service partner certified by us. If you enter into a maintenance contract at the same time, you are entitled to a warranty extension to five years. Take advantage of this opportunity easily at www.reflex-winkelmann.com/int/services-downloads/after-sales-service/warranty on our home page or simply use the sticker on your product to access registration.

Registration is not only possible at the time of commissioning but is also valid for all systems with a manufacturing date of up to six months from the year of manufacture 2020.

With the new online service order, we are optimising the service for our customers even further. It takes just a few clicks to create the order form, and it can be processed directly in our system. This makes our service even faster and more customer friendly.



Factory service centre

+49 2382 7069-9505
aftersales@reflex.de



Technical hotline

+49 2382 7069-9546
aftersales@reflex.de



Commercial processing

+49 2382 7069-7505
aftersales@reflex.de



Discover Reflex with augmented reality



1 Scan QR-Code.
reflex.de/en/city



2 Download the
Reflex Smart City app



3 Scan the title of this brochure
and explore

Always up to date

Further product literature and materials can be
downloaded at or hard copies ordered from
www.reflex-winkelmann.com/int/services-downloads



Thinking solutions.

Reflex Winkelmann GmbH
Gersteinstrasse 19
DE-59227 Ahlen
+49 2382 7069-0
info@reflex.de

A **WINKELMANN**
BUILDING+INDUSTRY BRAND

www.reflex-winkelmann.com/en