

ERV-IC Range

In-Ceiling Energy Recovery Ventilators



Introduction - Energy Recovery Ventilators

Fresh outside air must be supplied to indoor spaces to meet minimum mandated building code legislation (or greater volumes if required to improve occupant comfort) and provide make up air or positive room pressurisation where ever needed. However, providing fresh outside air to an indoor space comes with a significant energy penalty as any temperature differential between outside and inside increases the heating or cooling load required to condition this outside air to a space neutral temperature. The greater this differential, the greater the amount of energy required. Similarly, if the humidity present in the outside air exceeds that in the space it will need to be removed to maintain a space neutral condition. The removal of this excess humidity adds a latent component to the cooling load and further increases the energy required to maintain the desired room condition. The air conditioning necessary to provide outside air at a space neutral condition is known as the fresh air load ("FAL").

The most efficient way to remove this FAL is treat it separately to the normal sensible load that arises from the space use and the building fabric heat gain or loss by employing a dedicated outdoor air system ("DOAS"). An Energy Recovery Ventilator ("ERV") is a common form of DOAS which allows heat or energy to transfer between fresh outside air and air that is being exhausted outside in order to minimise the FAL.

Air Change have been manufacturing and supplying its in-ceiling DOAS ERV-IC Range for over 20 years to a vast array of projects across Australia. By using its unique air-to-air heat and energy recovery technology, the Air Change ERV range is able to significantly reduce the running costs of HVAC systems needing fresh outside air. With compact designs suitable for ceiling space installation and a wide product range available, there is an Air Change ERV-IC solution for any project.

Contact one of our experienced sales engineers for a detailed unit selection.

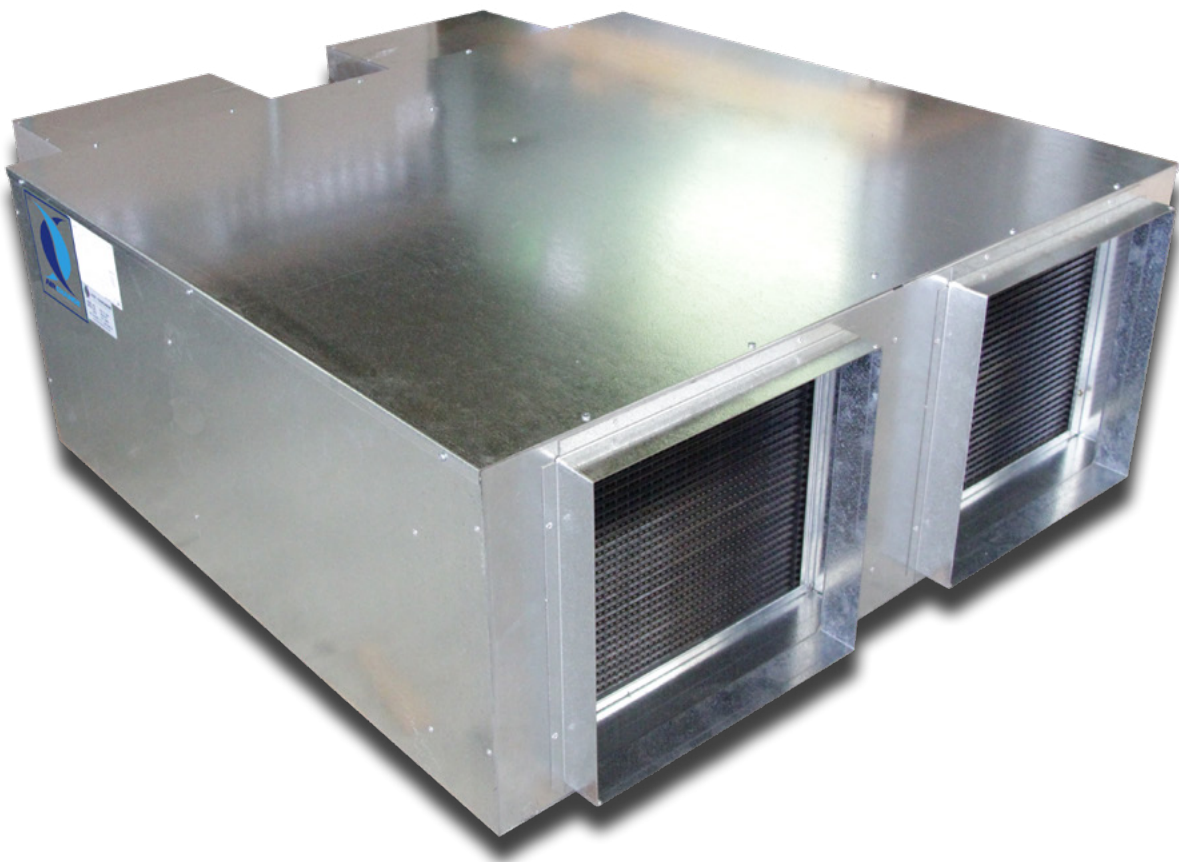

How it Works

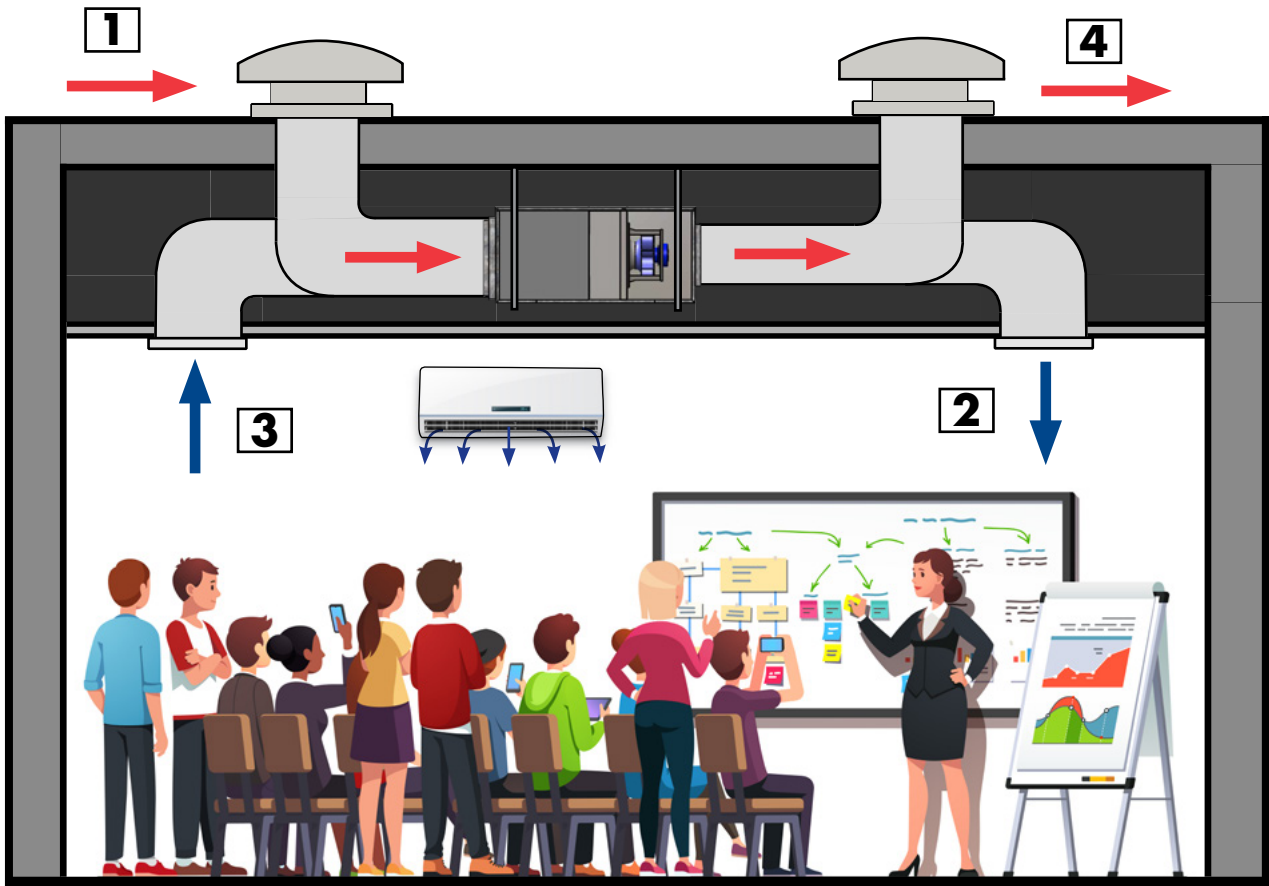

Cooling Scenario

1. 100% fresh outside air enters the unit and passes through an air-to-air heat / energy exchanger where it exchanges heat (and moisture) with the return air (stage 3) that is to be exhausted.
2. Once the air has been pre-cooled (or dehumidified) passing through the air-to-air heat / energy exchanger it is supplied to the space. Additional cooling can be provided by separate equipment running in series or parallel to the ERV.
3. Cool dry air returns to the unit where it exchanges heat / energy with the hot fresh air before it is exhausted from the building.
4. The now hot (and humid) return air from the space is exhausted outside.

Conversely, in a heating scenario the air-to-air heat exchanger provides preheating to minimise the outside air load. Separate equipment can provide additional heating when required.

Unit Plan View

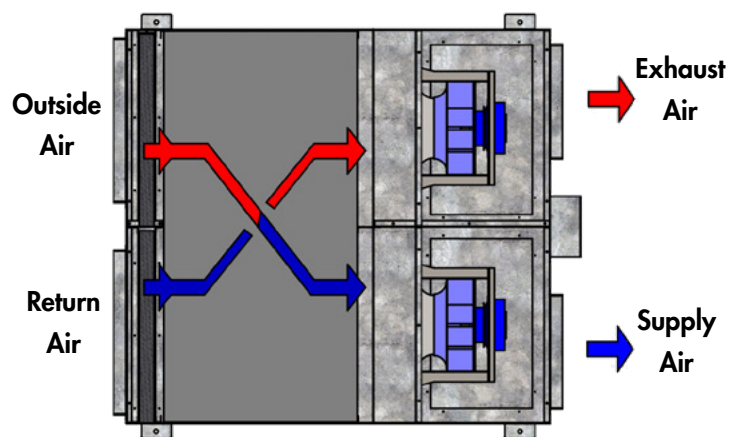

Airflow paths can be inverted i.e. outside air is swapped with return air, while exhaust air is swapped with supply air.

The Advantages

The air-to-air heat / energy exchanger provides significant year-round energy savings by providing precooling in summer and preheating in winter.

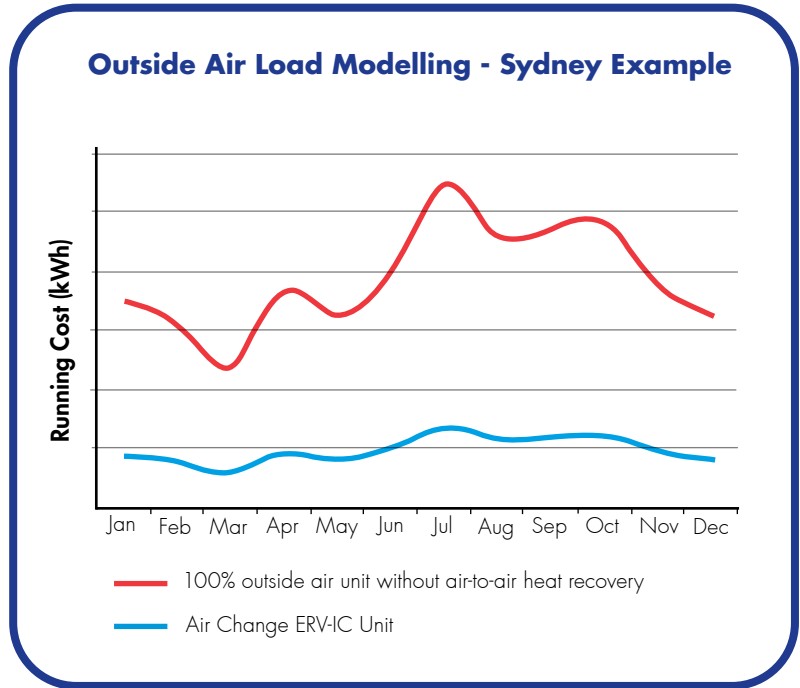

Two heat / energy exchanger transfer media options are available: the sensible-only type which allows only temperature to be exchanged (suitable for temperate climates), and the enthalpy type which allows humidity to be exchanged alongside temperature (suitable for tropical climates).

- Enthalpy type heat exchanger in humid climate
- Sensible-only type heat exchanger in temperate climate

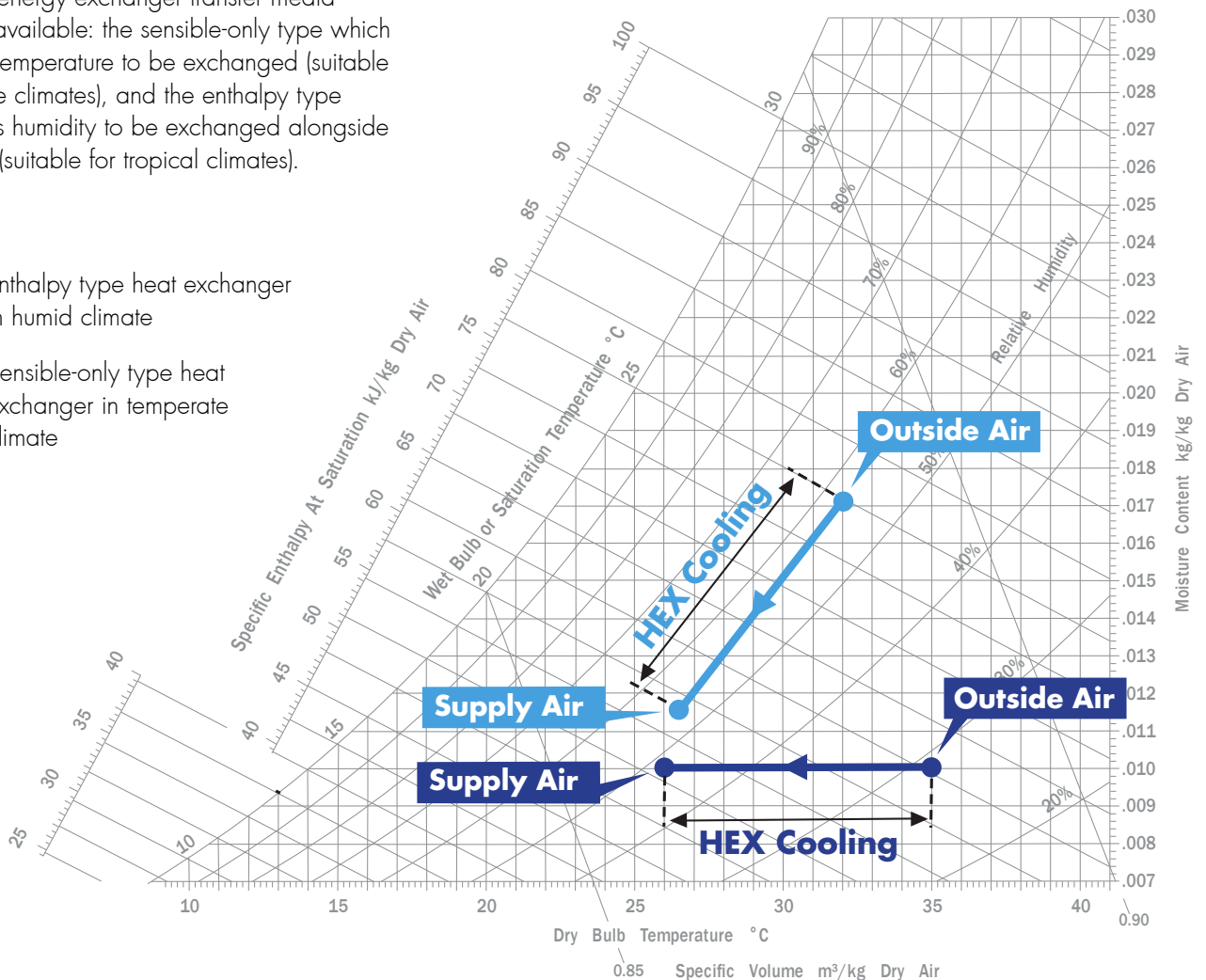

Air Change ERV-IC Product Ranges

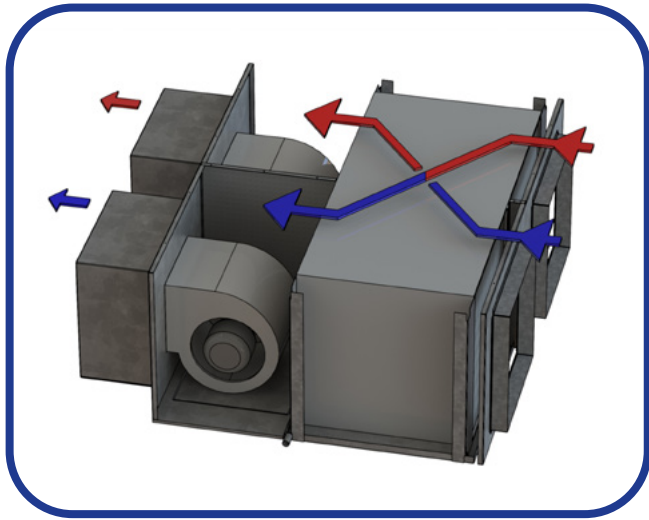

ERV-IC Units

The most basic in-ceiling ERV option. Forward curved centrifugal scroll fans are used for supply air and exhaust air.

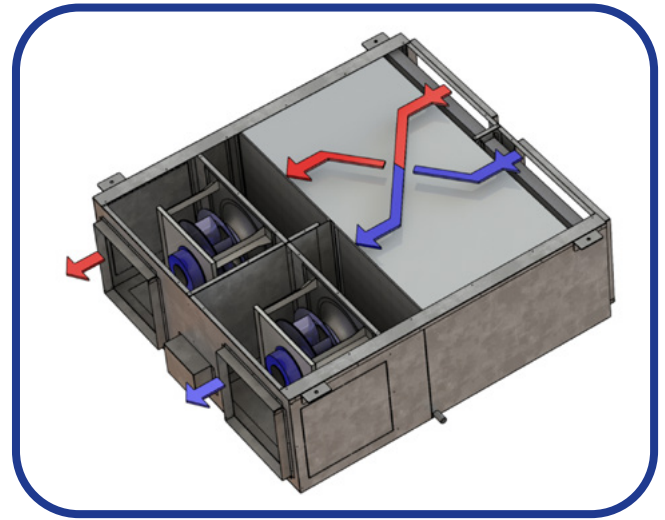

ERV-IC ECP Units

EC plug fans for supply air and exhaust air offer greater efficiency and static pressure development. G4 panel filters are also integrated into the unit. Supply and exhaust spigots can be relocated for side discharge and allow for greater installation flexibility.

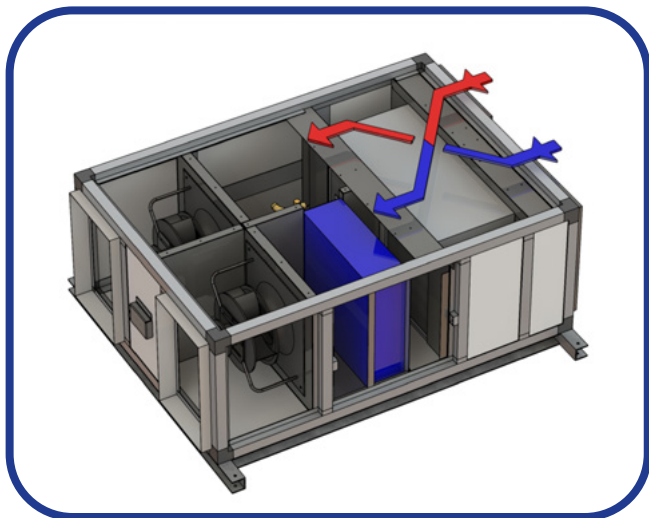

ERV-IC DX Units

Integrated DX coil and remote condensing unit for reverse cycle temperature control.

Contact your Air Change representative for more information.

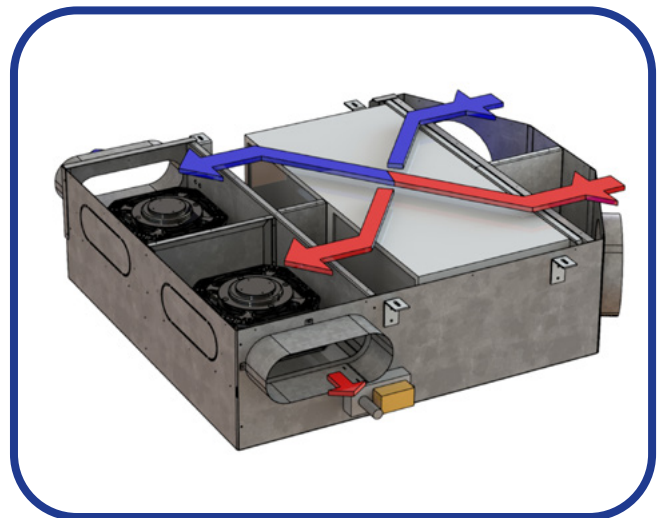

ERV-IC PC Units

Integrated pressure control system that allows the ERV unit to counteract positive or negative facade wind loads and maintain constant supply and exhaust airflow.

Contact your Air Change representative for more information.

ERV-IC Scroll Fan Range

(Model ERV-IC 70)

ERV-IC	
Model Number:	70
Nominal Supply Air (l/s)	70
Nominal Exhaust Air (l/s)	70
Outside Air	100%
HEX Media	Sensible-Only
Fan Type	EC Forward Curved Centrifugal Scroll
Static Pressure (Pa)	Refer to Fan Curve
Fan Motor Power (W)	25
Fan Speed Control	Potentiometer
Volts / Ph / Hz	240 / 1 / 50
Unit Full Load Amps (A)	1.2
Construction	Galvanised Sheetmetal with 12mm Film Faced PIR Insulation
Filters	Panel Filter Included (side access next to electrical box)
Dimensions	
Body Length (mm)	715
Body Width (mm)	860
Overall Height (mm)	180
OA / RA Spigot Size (mm)	Ø150
SA / EA Spigot Size (mm)	Ø150
Weight (kg)	25

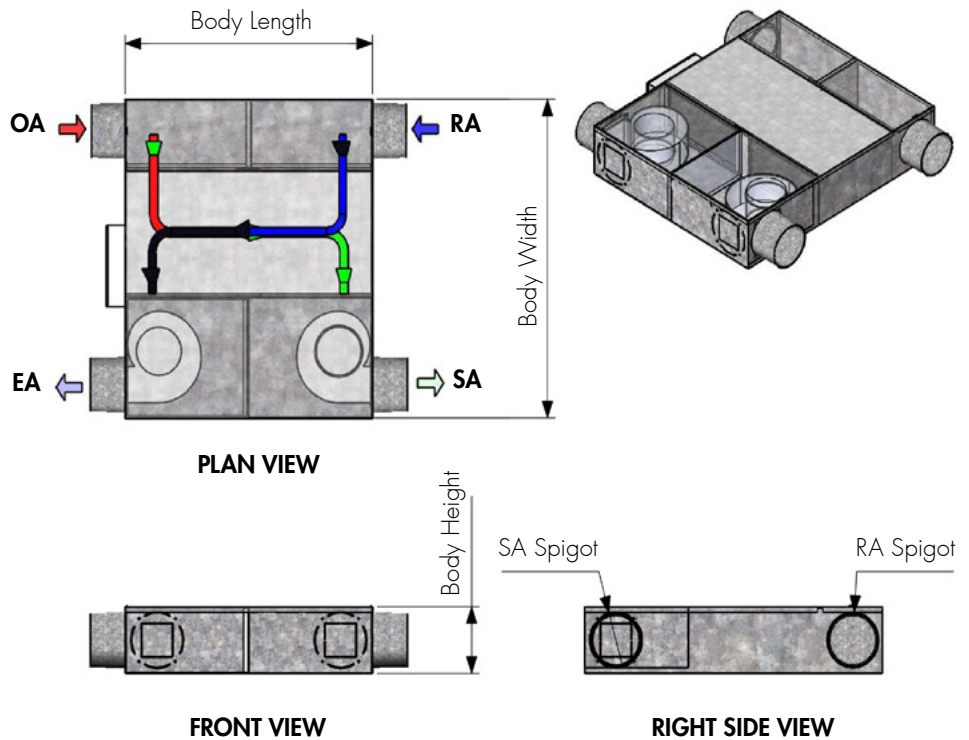

Note: The ERV-IC 70 has non-typical spigot locations compared to other Air Change ERV-IC units. Contact your Air Change representative for detailed dimensional drawings.

ERV-IC Scroll Fan Range

(Standard AC Scroll Fans)

ERV-IC					
Model Number:	200	300	400	600	900
Nominal Supply Air (l/s)	200	300	400	600	900
Nominal Exhaust Air (l/s)	200	300	400	600	900
Outside Air	100%				
HEX Media	Sensible-Only or Enthalpy				
Fan Type	AC Forward Curved Centrifugal Scroll				
Static Pressure (Pa)	Refer to Fan Curve				
Fan Motor Power (W)	100	130	240	950	950
Fan Speed Control	2 Speed	3 Speed	3 Speed	Potentiometer	Potentiometer
Volts / Ph / Hz	240 / 1 / 50				
Unit Full Load Amps (A)	2.7	2.7	3	10	10
Construction	Galvanised Sheetmetal with 12mm Film Faced PIR Insulation				
Filters	Filter Boxes Supplied by Others				
Dimensions					
Body Length (mm)	950	950	950	1220	1220
Body Width (mm)	800	800	800	1300	1500
Overall Height (mm)	350	450	450	500	650
OA / RA Spigot Size (mm)	Ø250	Ø350	Ø350	450 x 450	500 x 500
SA / EA Spigot Size (mm)	Ø250	Ø350	Ø350	400 x 400	500 x 500
Weight (kg)	58	90	90	195	275

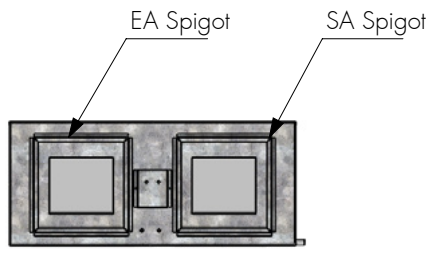
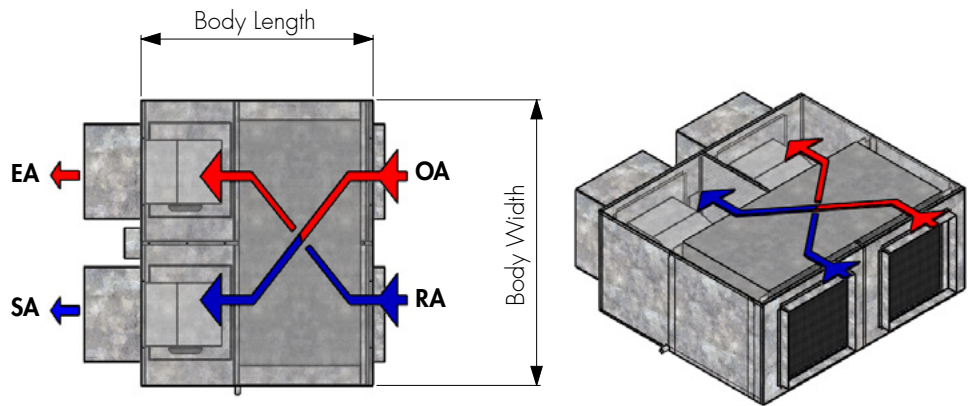

FRONT VIEW



RIGHT SIDE VIEW

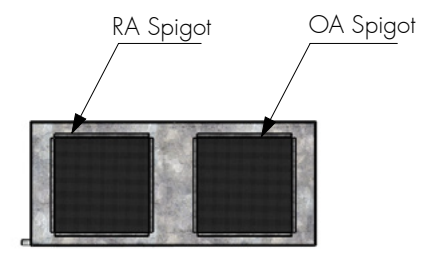

BACK VIEW

Note: Contact your Air Change representative for detailed dimensional drawings.

ERV-IC Scroll Fan Performance

ERV-IC 70

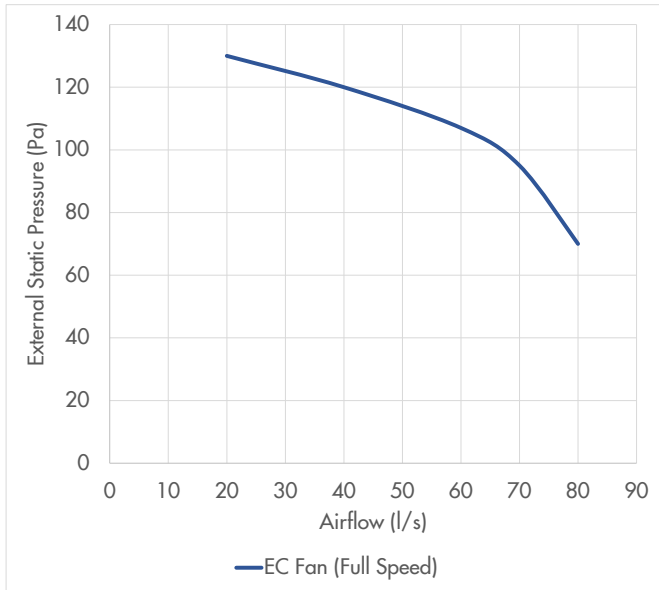

ERV-IC 200

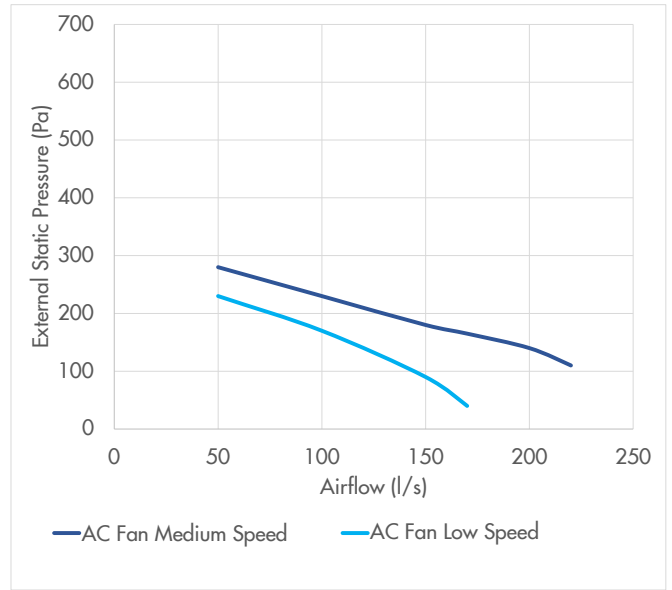

ERV-IC 300

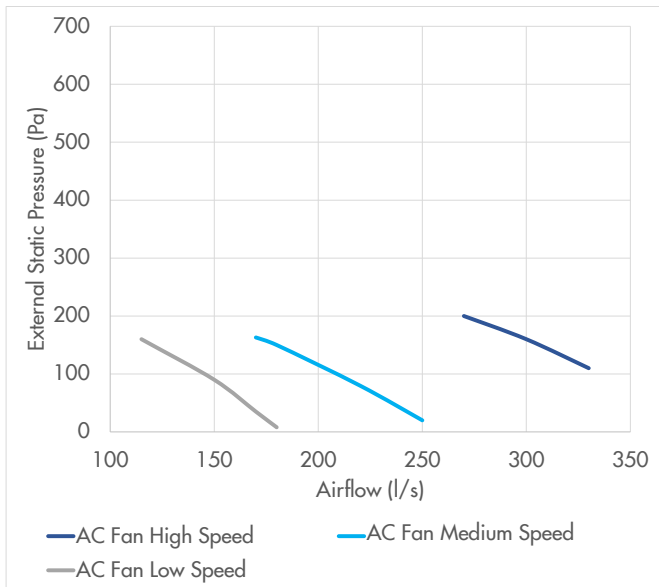

ERV-IC 400

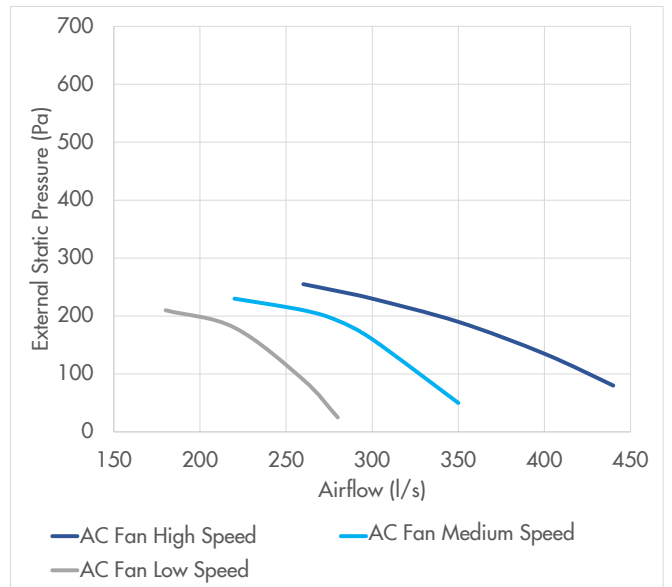

ERV-IC 600

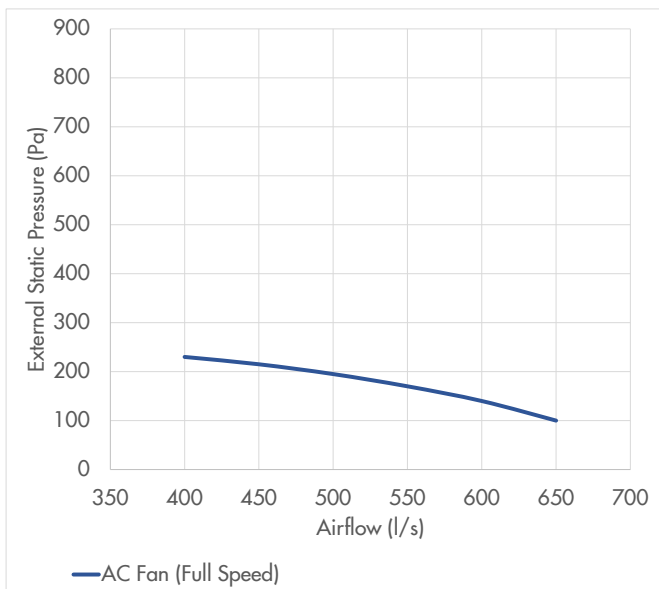

ERV-IC 900

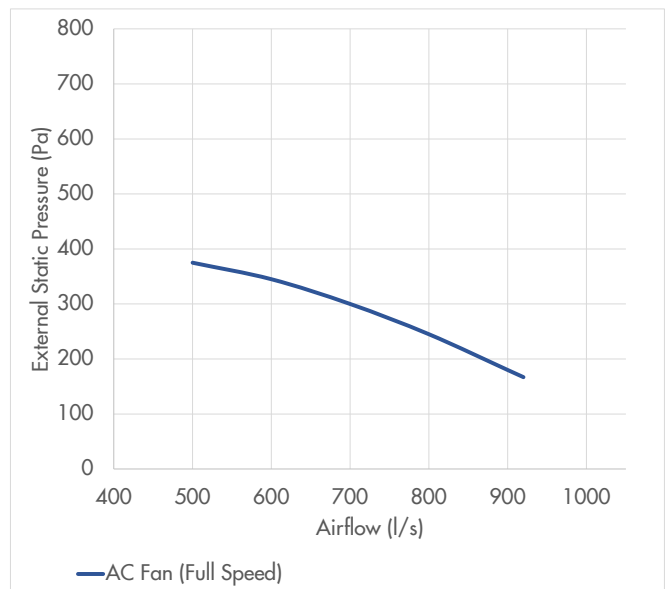

ERV-IC EC Plug Fan Range

ERV-IC XXX-ECP					
Model Number:	200	400	600	900	1200
Nominal Supply Air (l/s)	200	400	600	900	1200
Nominal Exhaust Air (l/s)	200	400	600	900	1200
Outside Air	100%				
HEX Media	Sensible-Only or Enthalpy				
Fan Type	EC Plug				
Static Pressure (Pa)	Refer to Fan Curve				
Nominal Fan Motor Power* (kW)	0.169	0.7	0.77	3.0	3.0
Fan Speed Control	0-10V Signal (by Others)				
Volts / Ph / Hz	240 / 1 / 50			415 / 3 / 50	
Unit Full Load Amps (A)	2.7	6.6	9.2	9.6	9.6
Construction	Galvanised Sheetmetal with 12mm Film Faced PIR Insulation				
Filters	Panel Filters Included (access from below)				
Dimensions					
Body Length (mm)	700	940	1400	1400	1450
Body Width (mm)	765	950	1350	1350	1350
Overall Height (mm)	350	450	500	650	850
OA / RA Spigot Size (mm)	295 x 295	395 x 395	540 x 440	540 x 590	500 x 700
SA / EA Spigot Size (mm)	295 x 295	295 x 295	375 x 375	375 x 500	500 x 600
Weight (kg)	80	110	220	300	400

*Typical running power consumption is significantly less than nominal power. Contact your Air Change representative for fan modelling data.

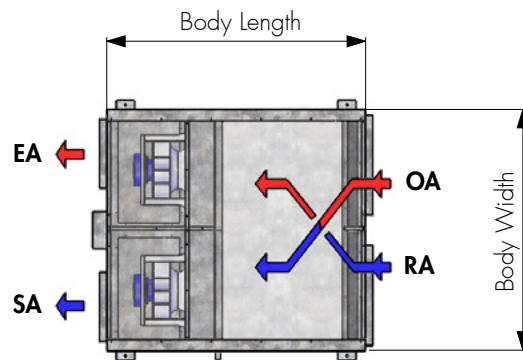

PLAN VIEW

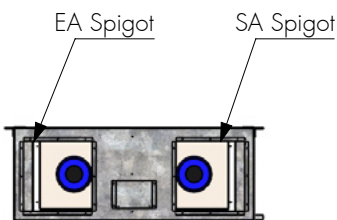
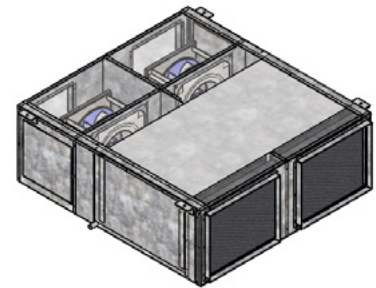

FRONT VIEW



RIGHT SIDE VIEW

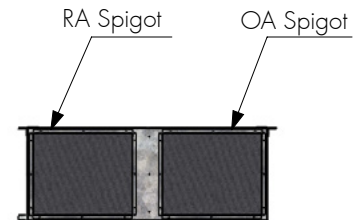

BACK VIEW

Note: Contact your Air Change representative for detailed dimensional drawings.

ERV-IC EC Plug Fan Performance

ERV-IC 200-ECP

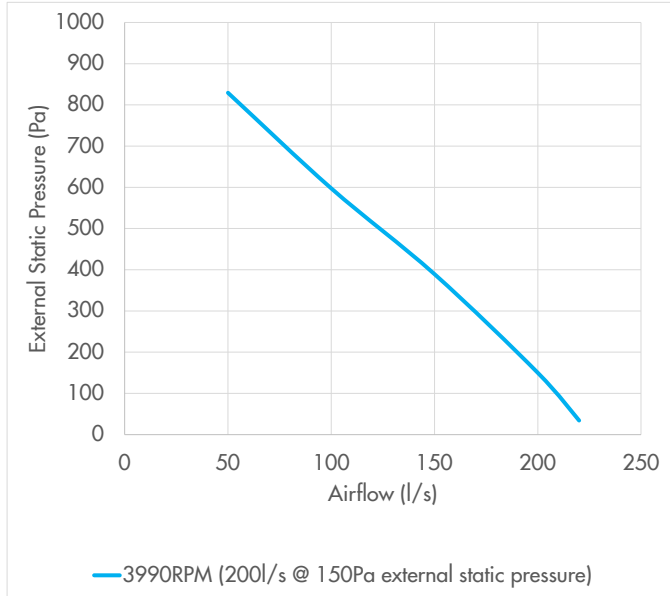

ERV-IC 400-ECP

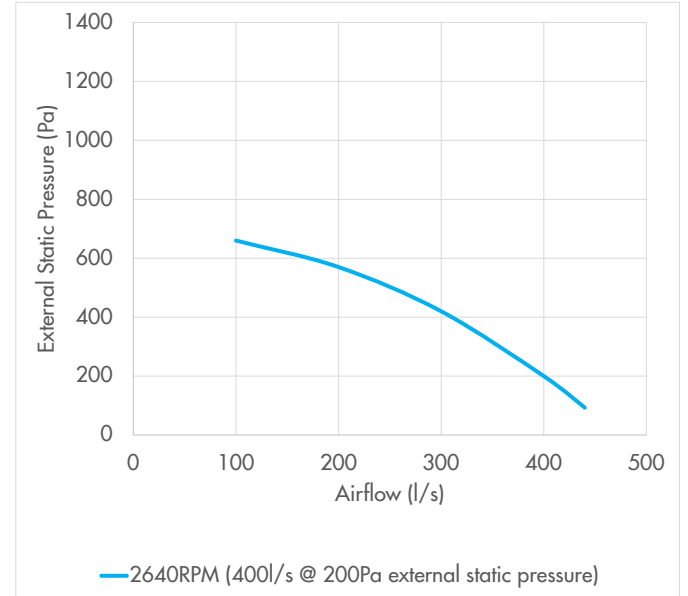

ERV-IC 600-ECP

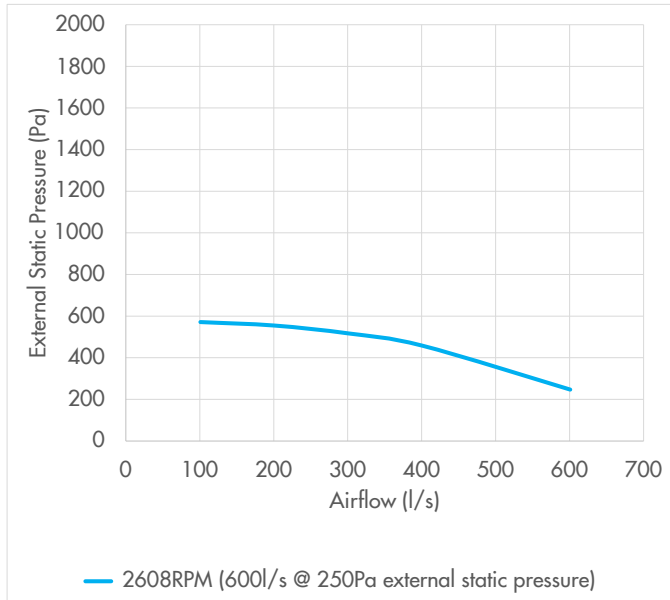

ERV-IC 900-ECP

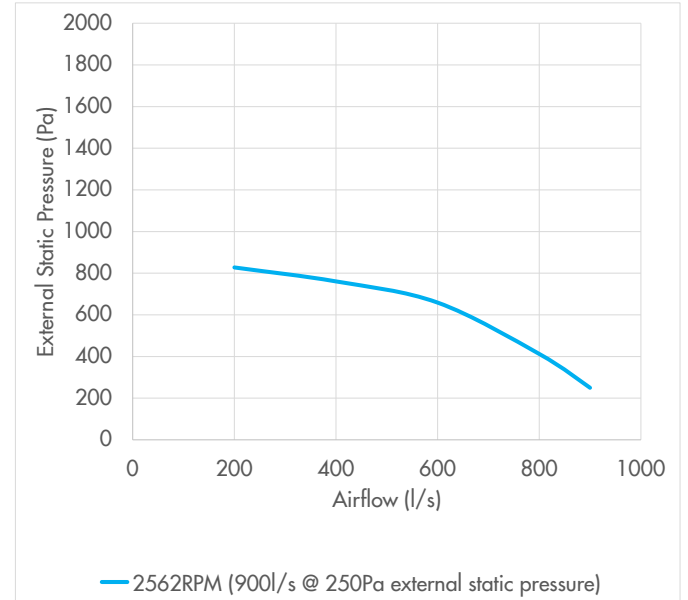

ERV-IC 1200-ECP

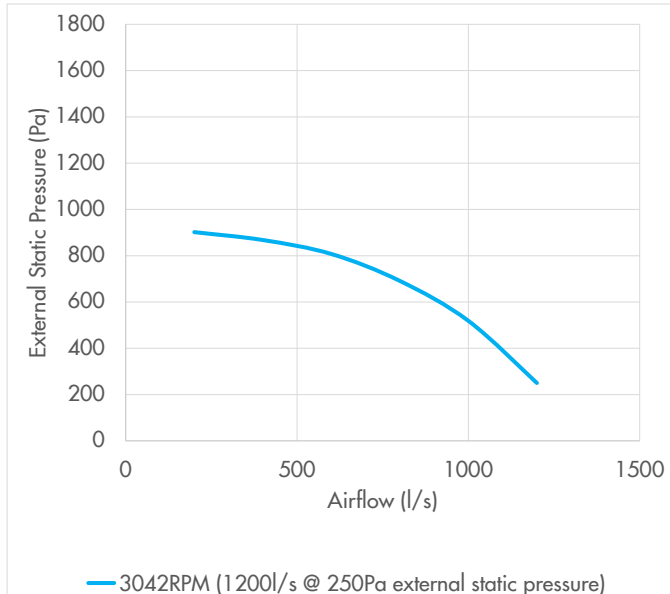

Contact Us

Air Change Australia

New South Wales (Head Office)

11 Broadhurst Rd, Ingleburn NSW 2565

Phone (02) 8774 1400

Email sales@airchange.com.au

Queensland

Unit 3, 78 Logan Rd,
Woolloongabba QLD 4102

Phone (07) 3414 3942

Email sales.qld@airchange.com.au

Victoria

Level 17, Tower 4 Collins Square,
272 Collins Street, Melbourne VIC 3008

Phone 0455 068 132

Email sales.vic@airchange.com.au

Australian Distributors

South Australia & Northern Territory

Industrial Air

14 Princess St, Beverley SA 5009

Phone (08) 8354 0088

Email info@industrialair.com.au

Website www.industrialair.com.au

Western Australia

Industrial Air

24 Wynyard St, Belmont WA 6104

Phone (08) 9418 2448

Email lenny@industrialair.com.au

Website www.industrialairwa.com.au

Air Change South East Asia

Malaysia

No 61, Jalan i-Park 1/1
Perindustrian i-Park 81000 Bandar
Indahpura, Johor

Phone (+60) 7662 6299

New Zealand Distributors

Cooke Industries

31 Station Rd, Penrose, Auckland 1061

Phone +64 (0)9 579 2185

Email sales@cookeindustries.co.nz

Website www.cookeindustries.co.nz

South East Asian Distributors

Thailand

Synergine (Thailand) Co.Ltd

18/6 Sukhumvit 22
Sukhumvit Rd, Khlong Toey
Bangkok 10110

Phone (+66) 851487312

Email w.manprasit@synergine.com.hk

Indonesia

PT Smart Chiller Systems

CEO Suites, One Pacific Place Tower
15th Floor, Jl. Jen. Sudirman Kav. 52-53
12190 Jakarta

Email mp@smardt-indonesia.com

Phone (+62) 21 2550 2413

Singapore

Energy Supplies & Engineering (S) Pte Ltd

61 Bukit Batok Crescent, #03-07B Heng
Loong Building, Singapore 658078

Contact 1- Desmond Tan

Email desmond@esengrg.com

Phone (+65) 9736 9956

Contact 2- Andrew Nah

Email andrew@esengrg.com

Phone (+65) 9771 8186



For more than 20 years, Air Change has provided unique equipment and engineering solutions for local and international clients using our internationally patented heat and energy recovery technology. During that time, we have developed a comprehensive range of energy efficient products to deliver controlled indoor climate conditions satisfying the requirements of all project stakeholders: the developer, the design engineer, and the building's owner and occupants.

www.airchange.com.au

© Air Change Australia Pty Ltd 2026

202604ERVIC

Air Change Pty Ltd products internationally patent protected

Refrigerant Trading Authorisation No: AU23586



Multi Award Winning Technology

ARBS Industry Awards "Product Excellence" Winner 2018

AIRAH "Product of the Year" Winner 2017

AIRAH "Excellence in Innovation" Winner 2012 & 2013