

YORK[®] X-Power Series YCAE-X Efficient and Intelligent Modular Air-Cooled Chillers/Heat Pumps





When your reputation is at stake, count on efficient, reliable cooling and heating solutions from YORK® to lower costs and maximize uptime with dependability you can count-on.

Have peace of mind in knowing that Johnson Controls has the largest service and preventative maintenance organization in the world.



With the inheritance of YORK® experience in modular chillers, the YORK® X-Power Series YCAE-X Modular Air-cooled Chillers and Heat Pumps are newly designed for exceptional performance.

Exceptional performance

With patented technology, this unit is designed for high performance.

History of reliability

Stable performance, quality parts, multiple verifications, and decades of experience and innovation.

Smart control

New-generation microcomputers support connection of up to 32 units, allows easy connection to the building automation system (BAS).

Flexible application

Meeting a variety of climates and locations without kits or add-ons.

Exceptional Performance

Efficient design

A parallel design with compressors: When an compressor operates, the heat exchange area of the air-side heat exchanger and the water-side heat exchanger can be fully utilized, to effectively improve unit performance, especially the part-load performance;

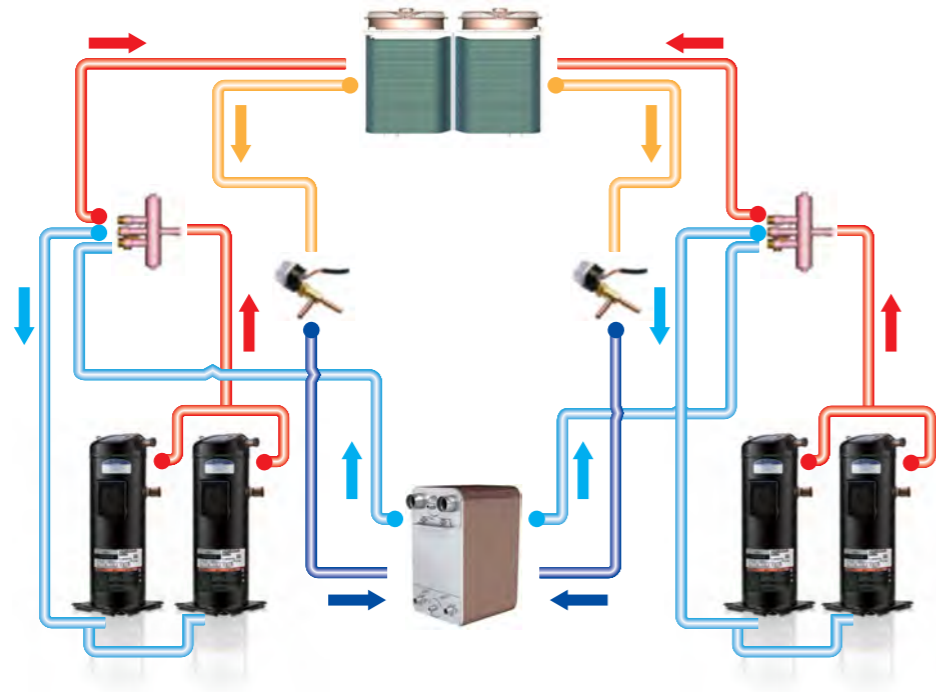

A design with two refrigerant systems and an independent air duct: The two refrigerant systems within a single module can easily achieve independent operation, lowering the fan's power consumption at part-load for improved performance;

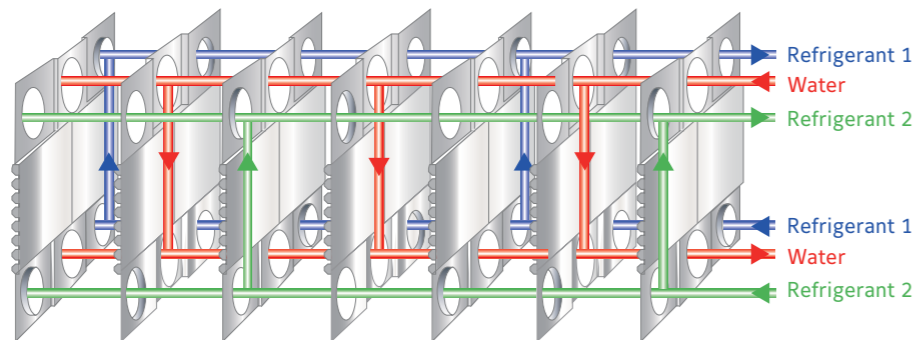

Multi-level energy regulation: An individual unit can realize up to four levels of energy regulation (0-25%-50%-75%-100%). Up to 32 units can be connected together with a wider range of energy regulation (as much as 128 levels), which is close to stepless regulation, have a higher efficiency and a better performance in saving energy.

Comfortable and quiet

To provide a quiet working and living environment, the YCAE-X series can operate w as low as 65 dB(A);

The two-fan design in single module:

This design allows the effective sharing of individual fan's air volume to lower the operation noise of individual fans;

Multiple noise-reduction options:

Optional unit baffles and the use of a noise reduction assembly, such as, the acoustic cotton can further reduce noise;

The new-generation microcomputer control center:

Monitors the operation in real time, and optimizes the option logic of the units to effectively reduce the start-stop noise of the units.



History of Reliability

Rich experience

The YORK® brand of Johnson Controls has over almost two decades of experience in designing, operating and servicing modular systems. Today there are over one million units of equipment operating across the country.



Reliable performance

Balancing of compressors operating time: Each compressor is monitored in real time, allowing for the operating time of each compressor is adjust for balance - extending the overall life of the unit.



Intelligent defrost

It can intelligently choose a defrost time based on the change in the unit's pressure and temperature. Manual defrost is also available.

The units can defrost and heat simultaneously without shutting down the equipment. When multiple modules are operating, the defrosting of a single unit doesn't impact the heating operation of the other modules.



Intelligent anti-freezing

In warmer months, the return water temperature of each unit is monitored in real time, to realize automatic antifreeze; In winter, the unit is equipped with triple automatic antifreeze measures, to effectively prevent the units from freezing.

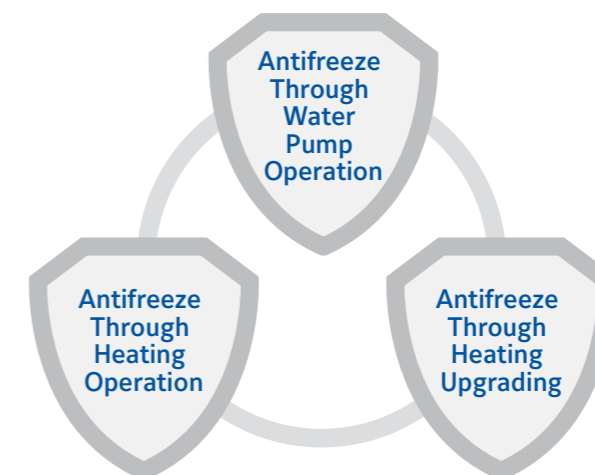

Reliable configuration

High Efficient R410A Hermetic Compressor

The low-pressure chamber structure is designed with crankcase in a lower-temperature area, and the motor is cooled by the refrigerant in the low-temperature return gas, which extends the motor's life.

With low-pressure chamber structure design, the crankcase is in a low-temperature area, and the motor is cooled by the refrigerant in the low-temperature return gas-extending the motor's life.

The air-side heat exchanger

- Unique U-shaped heat exchanger, multi-side heat transfer, and optimized wind field;
- Standard hydrophilic aluminum foil fins: for strong anti-oxidation and corrosion-resistance performance



Customized fan assembly

Large-diameter and round-angle axial fan blades, integrated bell mouth and wind scoop design, and IP55 double-speed motor for strong protection when installed outdoors.



Efficient stainless steel plate heat exchanger

The stainless steel structure provides stability and reliability; the asymmetric flow field design lowers the pressure drop on the water side and improves the antifreeze performance.

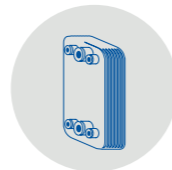

Electronic expansion valve

The 480-step high precision electronic expansion valves are used to make intelligent adjustments to the flow of the refrigerant. This ensures that the refrigerant flow is precise, and that the unit's operation pressure and temperature are optimal.

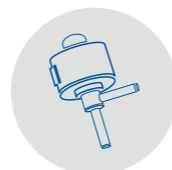

Filter & water flow switch

- The copper filter is standard to prevent dirt from entering the system, which prevents clogging;
- Provide water flow switch as standard to prevent the unit from being froze-cracked due to poor water flow.

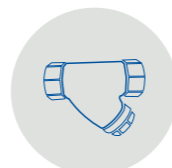

Reliable operation

Tested by the Highly Accelerating Lifecycle Testing Lab: Each model of the YCAE-X series has been tested in the Highly Accelerating Lifecycle Testing Lab. This test simulates various extremely harsh conditions encountered by the units under various weather conditions (e.g. wind, snow, rain, and frost). The entire year's operating conditions are simulated during a period of 2-4 weeks to ensure the reliable operation of the units in the field.

Highly Accelerating Lifecycle Testing Lab

Simulated ambient temperature: -25°C -60°C



Smart Control

Local control & communication

Two touch-screen controllers are provided for customers to choose from

Standard Wired controller: The controller is compact and beautiful with a user-friendly LCD touch-screen. It can be connected to up to 16 units. The range of the A/C system's cooling capacity can be expanded to 2,080 kW;



Optiview LT™ controller: The 7-inch color touch-screen can display more parameters than a standard controller. The multilevel user permission setup ensures the safe operation of the A/C system. The controller supports software upgrade via a USB, making it easy to maintain. It can be connected to up to 32 units, and the range of the A/C system's cooling capacity can be expanded to 4,160 kW.



Remote control & communication

The units have a RS-485 interface, which support the MODBUS/BACnet protocols for easy connection to the building automation system (BAS).

Building automation system (BAS)



Interlocking

- The YCAE-X series support the operation of a variable frequency water pump, to easily realize a variable flow primary pumping system, making the operation more energy-efficient.
- The YCAE-X series has a RS485 interface, so the host switch can be controlled through the T8600 networked thermostat.
- The YCAE-X series can connect two central controllers at the same time to meet the control requirements of two different groups of managers.
- The YCAE-X series support functions such as remote ON-OFF, remote heating-cooling switch, interlocking with terminal thermostat switch, and remote alarming.

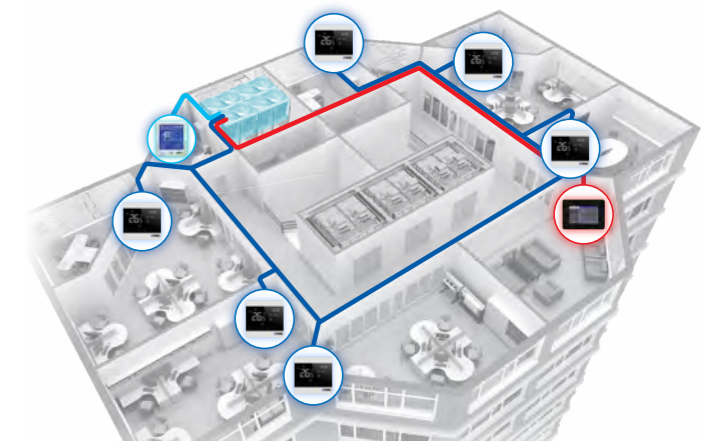

Schedule control

The customer can set a time (day or week, except for holidays) to have the units automatically turned on or off.



Flexible Application

Flexible configuration

YCAE100X and YCAE130X can be combined and connected together, to allow for more unit configuration;

Flexible options

Multiple configurations:

- Wire & Enclosure
- Spring Isolation with 1" distortion
- Sound kits
- Wired controller
- Smart View II controller
- SC-Equip assembly (converting BACnet)



Unit Operation Range

YCAE065X

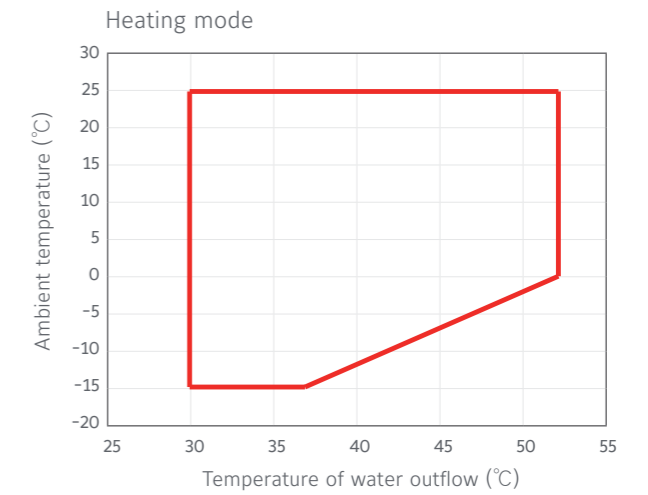
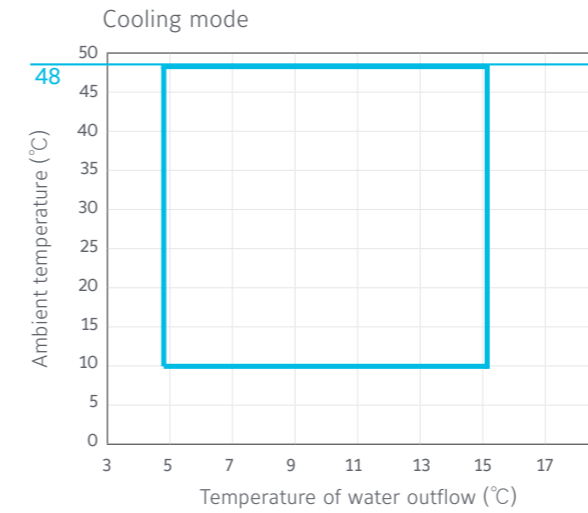

YCAE100/130X

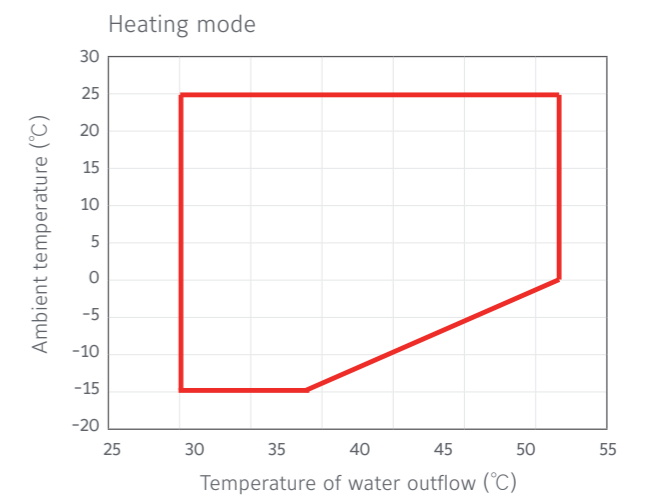
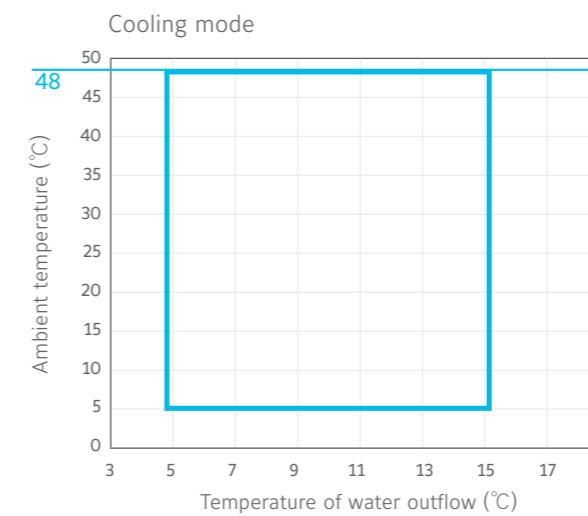

Dimensions

YCAE065X

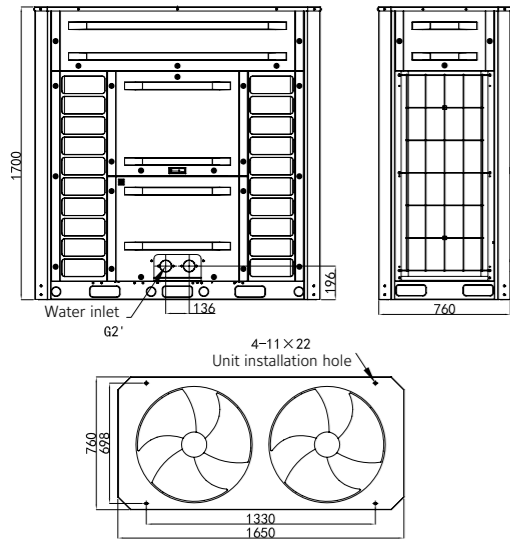

Grille and baffle are optional for the YCAE100/130X series

YCAE100/130X

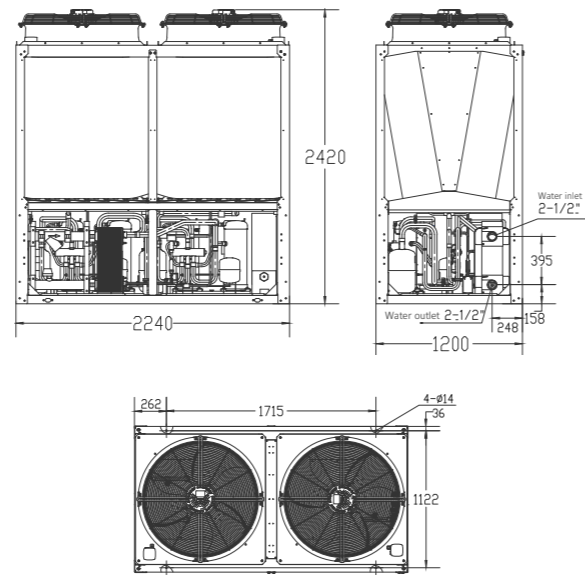
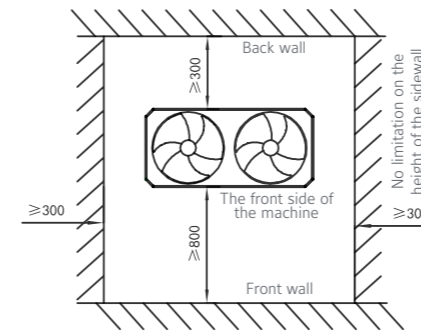

Illustration of Installation Interval

YCAE065X

Installation of a single unit



Installation of multiple units

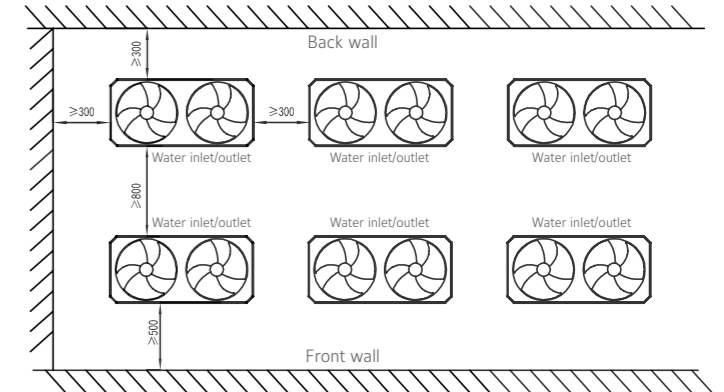

Note: See IOM for other installation styles. The height of the wall is not recommended to be higher than the installation height of the units

Weight Distribution

YCAE065X

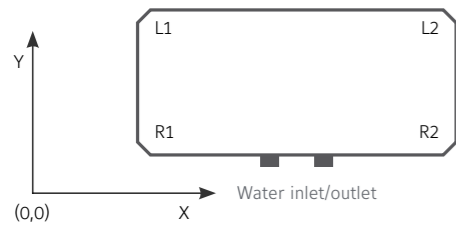

YCAE100/130X



		Unit	R1	L1	R2	L2
YCAE065XRME	Load	kg	127	112	130	109
	Location	(x-mm, y-mm)	(160,31)	(160,729)	(1490,31)	(1490,729)
YCAE100XRME	Load	kg	169	205	222	267
	Location	(x-mm, y-mm)	(262,36)	(262,1158)	(1977,36)	(1977,1158)
YCAE130XRME	Load	kg	212	264	235	272
	Location	(x-mm, y-mm)	(262,36)	(262,1158)	(1977,36)	(1977,1158)

YCAE100/130X

Installation of a single unit

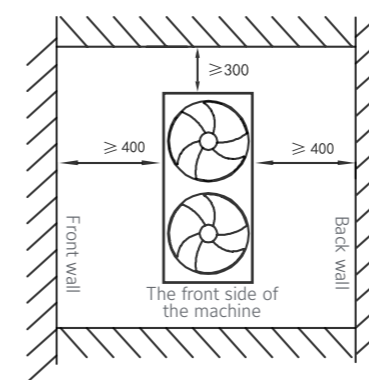

Installation of multiple units

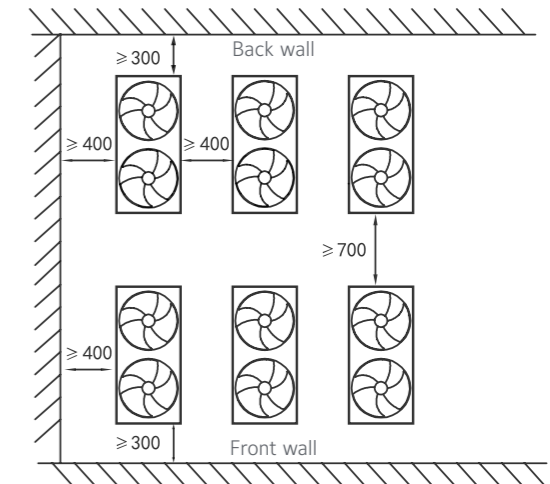
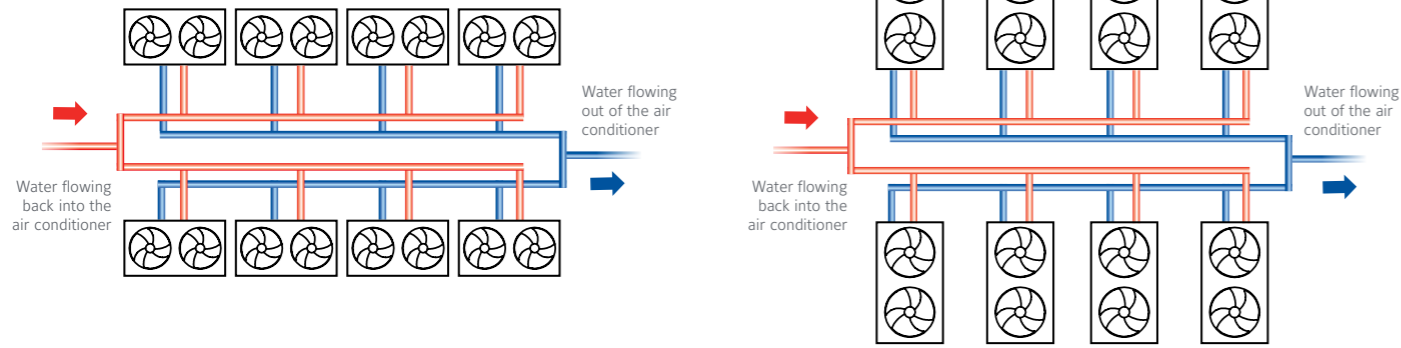

Illustration of units layout

YCAE065X

YCAE100/130X



Field Wiring

System Power Distribution

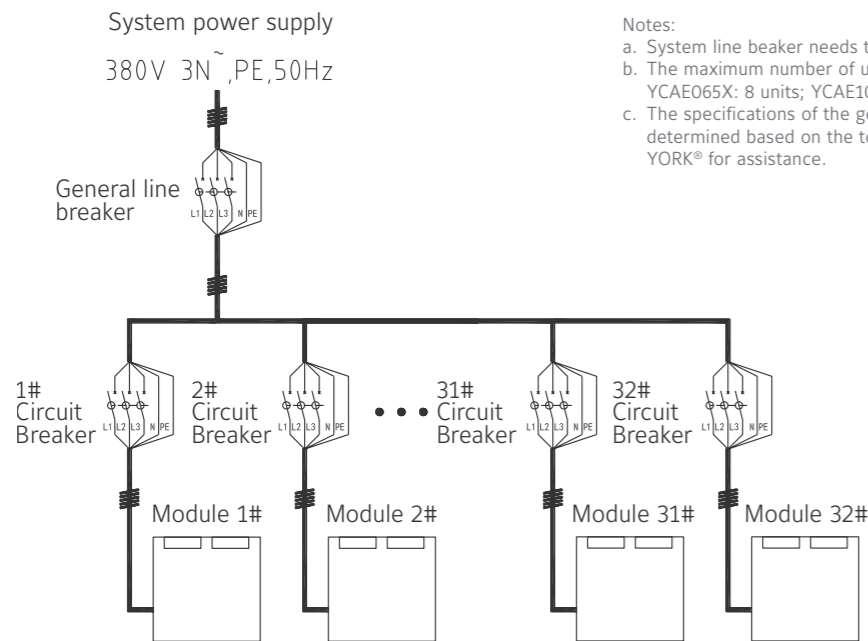

- Notes:
- System line breaker needs to be provided by the customer;
 - The maximum number of units that can be connected to the system currently:
YCAE065X: 8 units; YCAE100/130X: 16-32 units;
 - The specifications of the general line breaker and the power cable need to be determined based on the total load. Please contact the after-sales personnel of YORK® for assistance.

Field Wiring

YCAE065/100/130X Communication Network (Standard central controller)

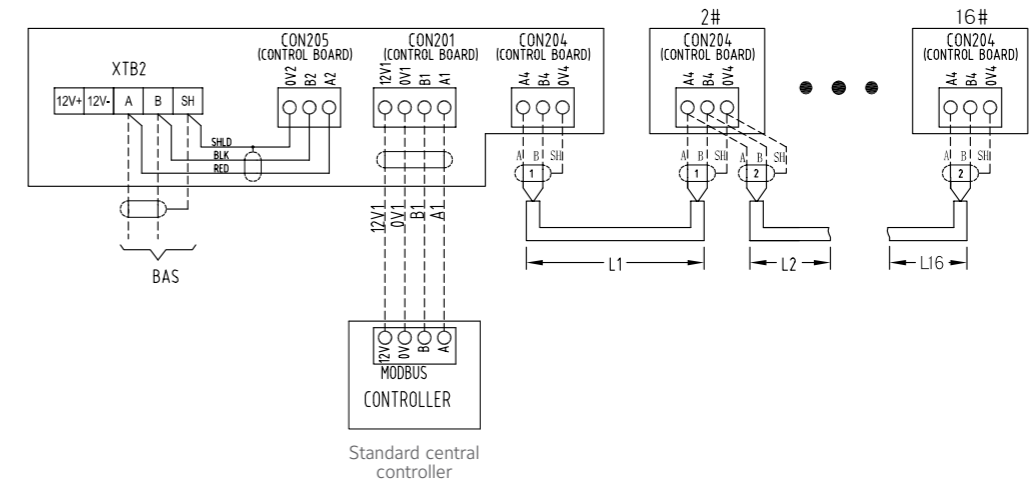

Telecommunications line requirement

The total length wires (From the wire control device to the last units)	L=L1+L2+...+L16(M)		
	L<100M	100M<L<500M	L>500M
The corresponding communication wire type	PVVPS 2×0.75mm ²	PVVPS 2×1mm ²	CONTACT JCI SERVICE

- Notes:
- Shielded twisted pairs are recommended for the communication lines.
 - Communications line to be provided by customer

YCAE065/100/130X Communication Network (Optiview LT™ controller)

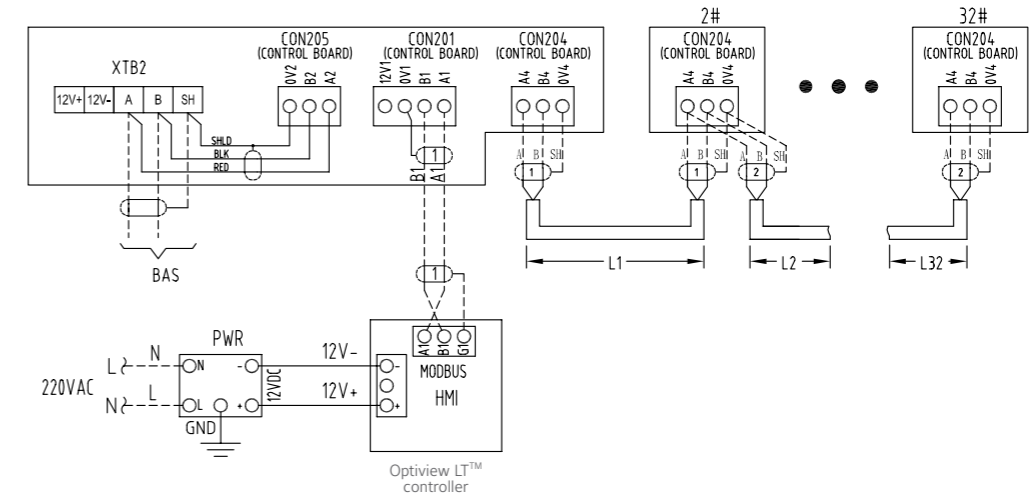

Telecommunications line requirement

The total length wires (From the wire control device to the last units)	L=L1+L2+...+L32(M)		
	L<100M	100M<L<500M	L>500M
The corresponding communication wire type	PVVPS 2×0.75mm ²	PVVPS 2×1mm ²	CONTACT JCI SERVICE

- Notes:
- Shielded twisted pairs are recommended for the communication lines.
 - Communications line to be provided by customer

Product Nomenclature

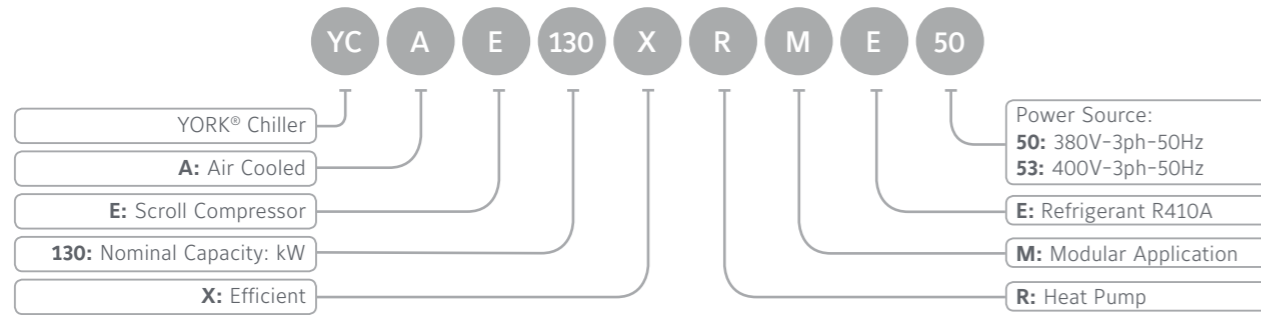

Technical Features

Model			YCAE065XRME	YCAE100XRME	YCAE130XRME
Nominal Cooling Capacity		kW	65.0	100.0	130.0
Nominal Heating Capacity		kW	66.0	100.7	131.9
Nominal Cooling Power Input		kW	20.4	29.2	39.3
Nominal Heating Power Input		kW	20.0	31.0	42.8
Power Source		V/ph/Hz	400/3/50		
Refrigerant			R410A		
Compressor	Type		Scroll		
	Quantity	Unit	2	3	4
Fan	Fan Quantity	Unit	2	2	2
	Volume	m ³ /h	11000x2	12500+21500	21500x2
	Fan Power	kW	0.9x2	0.87+1.65	1.65x2
	ESP	Pa	30	0	0
Water Side Heat Exchanger	Type		BPHE		
	Nominal Flow	m ³ /h	11.2	17.2	22.4
	Pressure Drop	kPa	61	60	60
	In/Out Piping		DN50	DN65	DN65
	Piping Connection		Threaded connection	Clamp connection	Clamp connection
Dimension	L x W x H	mm	1650x760x1700	2250x1200x2420	2250x1200x2420
Unit Weight	Operation Weight	kg	503	864	982
	Rated Current (Cooling/Heating)	A	37.4/36.7	55/58	74/80
Electric	Max. Current	A	52	85	112

Nominal conditions:
Cooling capacities in kW given for 12/7°C water leaving temperature and 35°C(DB) ambient temperature.
Heating capacities in kW given for 40/45°C water leaving temperature and 7°C (DB) ambient temperature



About Johnson Controls' Building Technologies and Solutions

Johnson Controls' Building Technologies & Solutions is making the world safer, smarter and more sustainable – one building at a time. Our technology portfolio integrates every aspect of a building – whether security systems, energy management, fire suppression or HVACR – to ensure that we exceed customer expectations at all times.

We operate in more than 150 countries through our unmatched network of branches and distribution channels, helping building owners, operators, engineers and contractors enhance the full lifecycle of any facility. Our arsenal of brands includes some of the most trusted names in the industry, such as Tyco®, YORK®, *Metasys*®, Ruskin®, Frick®, PENN®, Sabroe®, Simplex® and Grinnell®.

For more information, visit www.johnsoncontrols.com or follow @JCI_Buildings on Twitter.

Australia (Sydney)
Tel: +61 (2) 9805 8300
Fax: +61 (2) 9247 7750

India (Mumbai)
Tel: +91 (22) 6683 7000
Fax: +91 (22) 6683 7002

Malaysia (Kuala Lumpur)
Tel: +60 (3) 7628 4300
Fax: +60 (3) 7874 1180

China (Shanghai)
Tel: +86 (21) 2285 7000
Fax: +86 (21) 2285 7599

Indonesia (Jakarta)
Tel: +62 (21) 5366 8500
Fax: +62 (21) 5366 8300

New Zealand (Auckland)
Tel: +64 (9) 635 0880
Fax: +64 (9) 633 1862

China (Hong Kong)
Tel: +852 2885 4451
Fax: +852 2885 7760

Japan (Tokyo)
Tel: +81 (3) 5738 6100
Fax: +81 (3) 5738 6298

Singapore
Tel: +65 6748 0202
Fax: +65 6743 4420

China (Macau)
Tel: +853 2875 1820
Fax: +853 2875 1825

Korea (Seoul)
Tel: +822 1588 9117
Fax: +822 6009 9014

Thailand (Bangkok)
Tel: +66 (2) 794 0101
Fax: +66 (2) 717 1327-8