



SUSSMAN

ELECTRIC BOILERS

ES Series

Lbs/Hr Sat. Steam: 36 to 542

KW Rating: 12 to 180

ASME Rating 100 PSIG

Operating PSIG Range 0-80 PSIG Max

ES Electric Steam Boilers

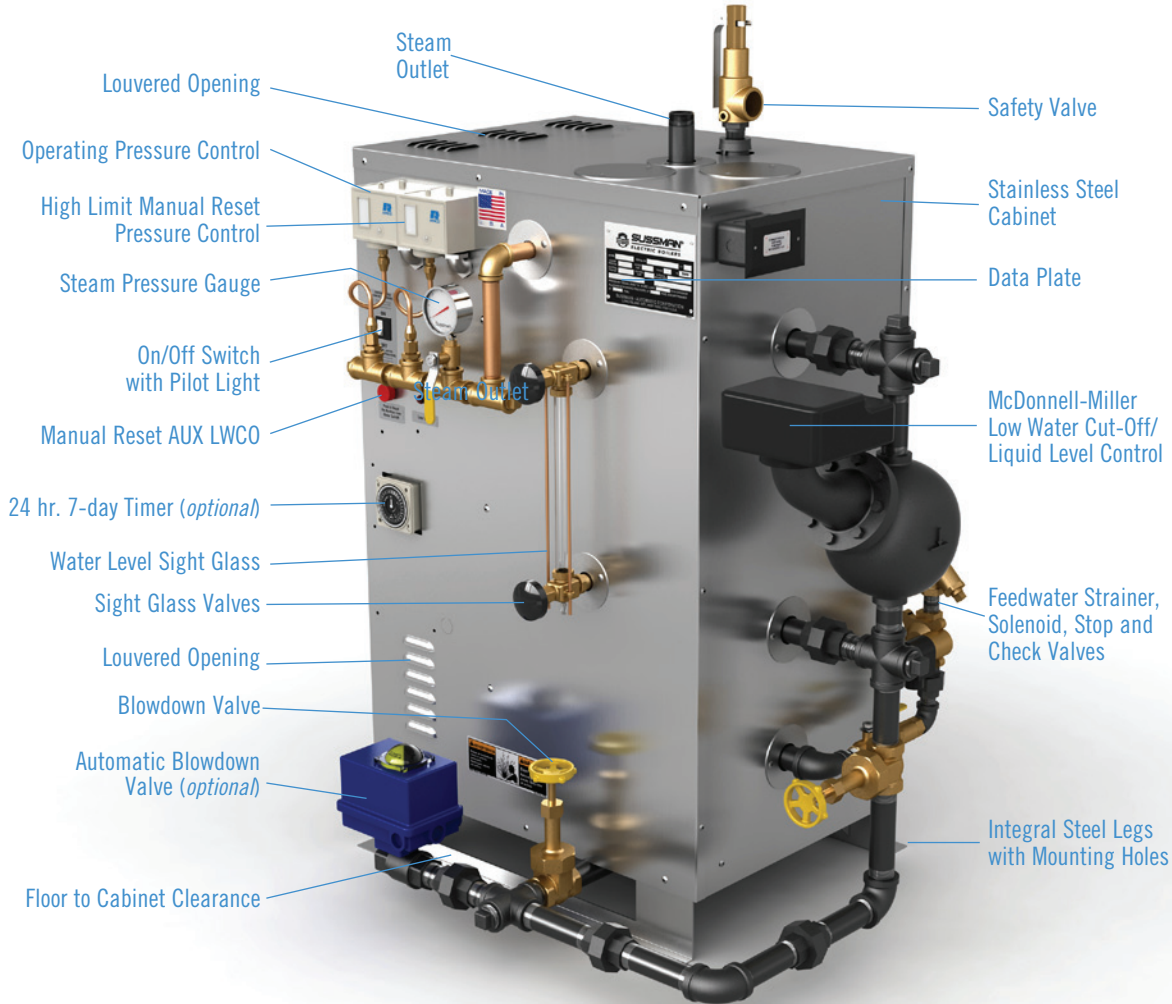

Typical boiler arrangement

Features Not Shown:

- Electronic Aux LWCO
- Section 1 Carbon Steel ASME Pressure Vessel
- Stainless Steel Heating Elements

Boiler Model No.	Water Inlet	Steam Outlet
ES 12 - ES 18	1/2" NPT	1/2" NPT
ES 24 - ES 72	1/2" NPT	1" NPT
ES 85 - ES 100	1/2" NPT	1-1/2" NPT
ES 135 - ES 180	1/2" NPT	2" NPT



Built to ASME Code **E**

Sussman ES Packaged Electric Steam Boilers

Suitable for industries requiring efficient, high quality saturated steam, including laboratories, hospitals, industrial plants, pilot plants and chemical processing applications.

These versatile generators are perfect for almost any application requiring steam from 0-80 PSIG. Each unit is complete with automatic features, including pressure and liquid level controllers, ASME Code pressure vessel and safety valve and are fully tested under power. Each one must pass Sussman's rigid quality control inspection before it is shipped.

Sussman Electric Boilers - your source for fast economical steam energy.

ES Series Features:

- Safe easy-to-use heat source. No on-site products of combustion
- Easy, quick to install, they require only a water feed connection and electrical hook-up
- Applications include: Steam for tanks, reactors, distillations, autoclaves, dyestuffs, cosmetics, paraffins, glues, steam jacketed kettles, sterilizers, pipe tracing and humidification.
- Built to Section 1 of ASME Boiler and Pressure Vessel Codes. UL listed.

ES-Standard Features

- **WATER FEED SYSTEM** - Strainer, solenoid valve, stop valve and check valve factory wired and plumbed for direct connection to water line.
- **LOW WATER CUT-OFF/LEVEL CONTROL** - McDonnell Miller No.150 control automatically maintains proper water level, shutting off the boiler when water supply in the boiler drops below a safe operating level.
- **WATER LEVEL SIGHT GLASS** - Allows constant observation of water level while boiler is in operation.
- **MAIN ON/OFF SWITCH** - Allows manual operation of the boiler operating control circuit.
- **PILOT LIGHT** - Indicates control circuit's on/off condition.
- **INTEGRAL POWER CONTACTORS** - Magnetic contactors for energizing the boiler elements. Integrally mounted in the control unit.
- **BLOWDOWN/DRAIN VALVES** - Facilitates emptying the boiler pressure vessel and MM150 water column piping during blowdown sequence.
- **LONG LIFE HEATING ELEMENTS** - Industrial grade, heavy duty 0.420 inch diameter stainless steel heating elements, equipped with one piece resistance welded terminations for added strength and safety.
- **OPERATING PRESSURE CONTROL** - Resets automatically to maintain preset pressure within boiler.
- **ENERGY SAVINGS AND MINIMUM MAINTENANCE** - Pressure vessel insulation minimizes heat loss and maximizes energy savings, insured by fibrous glass material.
- **EASY CONTROL MAINTENANCE** - All control panels and components are easily accessible. Fully-louvered openings avoid component heat build-up.
- **NEMA 1 Louvered enclosure standard**
- **TRIM PRESSURE-** Factory standard 100 PSIG or 15 PSIG

Meeting Code Requirements

- Pressure vessel rated at 100 PSIG to ASME Section 1. Vessel National Board Registered
- UL and cUL Listed
- Electrical construction conforms to NEC standards.

Safety Features

- **STEAM SAFETY VALVE** - Automatically opens to reduce pressure should excessive steam cause pressure build-up.
- **STEAM PRESSURE GAUGE** - Allows visual observation of steam pressure over full range.
- **MANUAL RESET PRESSURE CONTROL** - Provides high limit pressure cut-out with manual reset.
- **AUXILIARY LWCO with Manual Reset** - Standard electronic back-up to primary MM150 control.

Optional Equipment

- **OPTIONS AVAILABLE :** Motor/Pumps, Condensate Return Systems, Step Sequencers, Automatic Blowdown Systems, Blowdown Separators and Transformers.

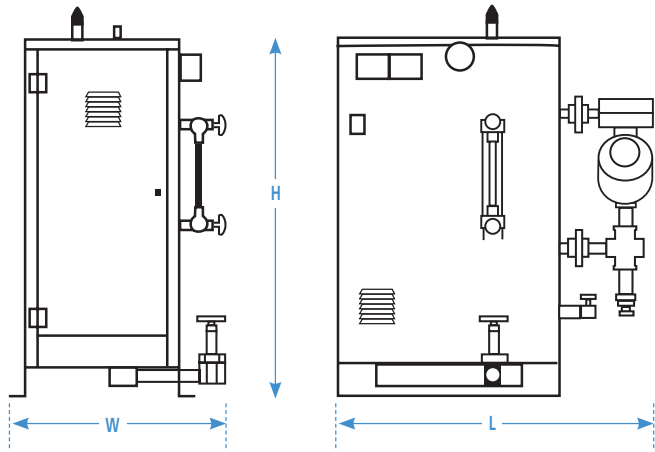

Specifications for ES Boilers

Boiler Model	kW*	BHP Rating	Lbs./Hr. Steam**	3 Phase Voltaget	Amps	Dimensions (in)			Shipping Wt.
						W	L††	H	
ES-12*	12	1.22	36.2	208 240 480	34 29 15	20	28	36	200
ES-18*	18	1.84	54.2	208 240 480	50 44 22	20	28	36	200
ES-24*	24	2.45	72.3	208 240 480	67 58 29	23	33	44	330
ES-30*	30	3.06	90.4	208 240 480	84 73 37	23	33	44	330
ES-36*	36	3.67	108	208 240 480	100 87 44	23	33	44	330
ES-48	48	4.90	145	208 240 480	134 116 59	23	33	44	330
ES-60	60	6.12	181	208 240 480	167 145 73	23	33	44	330
ES-72	72	7.35	217	208 240 480	200 174 87	23	33	44	330
ES-85	85	8.5	256	208 240 480	236 204 102	28	34	59	680
ES-100	108	11.0	325	208 240 480	300 260 130	28	34	59	680
ES-135	144	14.6	433	208 240 480	400 347 173	30	36	59	680
ES-160	158	16.1	475	240 480	379 190	30	36	61	680
ES-180	180	18.4	542	240 480	434 217	30	36	61	680

Notes: * Single phase available
 **Lbs/hr steam at 212° F with 50° F feedwater
 † Other voltages available
 ††Allow 21 inches for heating element removal

PUR 100217 8/13



A Division of Sussman-Automatic Corporation
 43-20 34th Street, Long Island City, NY 11101
 (718) 937-4500 • 1-800 238-3535 • Fax: (718) 937-4676
 www.sussmanboilers.com • Email: seb@sussmancorp.com