

SPECIAL CARBON STEEL MODULAR TANK TREATED WITH EXTERNAL ANTI-RUST PAINT



The new **TLR** range of water storage tanks extends the possibility of customising the tanks to adapt them to a very wide range of needs, allowing both the thermal performance of the various components and their arrangement in the layout of the system to be maximised. There are a large number of complete options to choose from.



1. CAPACITY: from 100 to 5000 litres;
 2. VERSION: they can be manufactured, in the larger sizes, with LOW and EXTRA-LOW heights to allow them to be installed in circumstances where the available height is not sufficient for the standard measurement;
 3. OPERATING PRESSURE: from 6 bar to 10 bar;
 4. CONSTRUCTION MATERIAL: carbon steel painted externally;
 5. INSULATION:
 - Closed cell anti-condensation expanded elastomer for AIR CONDITIONING circuits, with thickness of 20 mm or 40 mm for situations with large thermal differences;
 - 20 mm thick closed cell anti-condensation expanded elastomer coupled with 75 mm thick PLFH (polyester fibre) thermal insulation, suitable for mixed HOT/COLD systems where it is necessary to guarantee perfect operation during both winter and summer, in accordance with ERP standard with regard to storage dispersions during heating;
 - PLFH (polyester fibre) thickness 100 mm for tanks installed in HEATING systems, to reduce the waste of energy with respect to the parameters of the ErP standard;
 6. EXTERNAL CLADDING: TECHNICAL FABRIC with CHOICE OF COLOUR or embossed ALUMINIUM sheeting for installations in adverse weather conditions;
 7. TYPE OF CONNECTIONS: threaded (GAS/M), flanged PN16 or Victaulic;
 8. INTERNAL JET BREAKER: with MICRO-PERFORATED PLATE or with 3 offset DIVIDERS, for optimising the thermal distribution inside the tank.
- TLR**, thanks to its modularity it can be truly adapted to all situations, either for technical reasons or for appearance, to achieve a storage unit "sewn" onto the system and to obtain greater order and space inside the thermal system, with the advantage of reducing the production and maintenance costs of the various components present.

SPECIFICATIONS

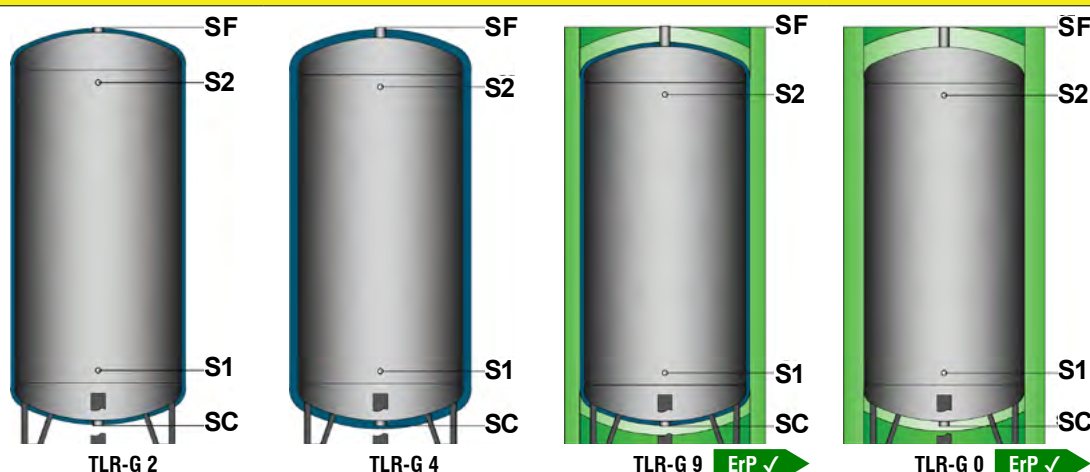

	TLR-G 2	TLR-G 4	TLR-G 9 ErP ✓	TLR-G 0 ErP ✓
TANK MATERIAL	Carbon steel	Carbon steel	Carbon steel	Carbon steel
INTERNAL SURFACE TREATMENT	—	—	—	—
EXTERNAL SURFACE TREATMENT	Anti-rust painting	Anti-rust painting	Anti-rust painting	Anti-rust painting
CAPACITY	100-5000 litres	100-5000 litres	100-5000 litres	100-5000 litres
VERSION	Vertical	Vertical	Vertical	Vertical
CONNECTIONS	SF (Air vent) 1"¼ S1-S2 (Probes) ½" SC (Drain) 1"¼ (100-2500 l) SC (Drain) 2" (3000-5000 l)	SF (Air vent) 1"¼ S1-S2 (Probes) ½" SC (Drain) 1"¼ (100-2500 l) SC (Drain) 2" (3000-5000 l)	SF (Air vent) 1"¼ S1-S2 (Probes) ½" SC (Drain) 1"¼ (100-2500 l) SC (Drain) 2" (3000-5000 l)	SF (Air vent) 1"¼ S1-S2 (Probes) ½" SC (Drain) 1"¼ (100-2500 l) SC (Drain) 2" (3000-5000 l)
ANTI-CONDENSATION INSULATION	Expanded elastomer closed cell, non removable 20 mm	Expanded elastomer closed cell, non removable 40 mm	Expanded elastomer closed cell, non removable 20 mm	—
HEAT INSULATION	—	—	PLFH (High density polyester fibre), removable 75 mm	PLFH (High density polyester fibre), removable 100 mm
CLADDING	<ul style="list-style-type: none"> • PVC Blue RAL5015 • Aluminium 	<ul style="list-style-type: none"> • PVC Blue RAL5015 • Aluminium 	<ul style="list-style-type: none"> • PVC Light grey RAL 7035 • Aluminium 	<ul style="list-style-type: none"> • PVC Light grey RAL 7035 • Aluminium
CLADDING AS REQUESTED (Without surcharge)	<ul style="list-style-type: none"> • PVC Yellow RAL1023 • PVC Orange RAL2004 • PVC Red RAL3000 • PVC White RAL9016 • PVC Light grey RAL 7035 • PVC Dark grey RAL 7024 • PVC Black RAL9004 	<ul style="list-style-type: none"> • PVC Yellow RAL1023 • PVC Orange RAL2004 • PVC Red RAL3000 • PVC White RAL9016 • PVC Light grey RAL 7035 • PVC Dark grey RAL 7024 • PVC Black RAL9004 	<ul style="list-style-type: none"> • PVC Light grey RAL 7035 • PVC Orange RAL2004 • PVC Red RAL3000 • PVC White RAL9016 • PVC Blue RAL5015 • PVC Dark grey RAL 7024 • PVC Black RAL9004 	<ul style="list-style-type: none"> • PVC Light grey RAL 7035 • PVC Orange RAL2004 • PVC Red RAL3000 • PVC White RAL9016 • PVC Blue RAL5015 • PVC Dark grey RAL 7024 • PVC Black RAL9004

NOTE: the composition of the special modular tanks model **TLR-G 9** and **TLR-G 0**, up to the capacity of 2000 litres, must be approved by our Technical Department for ErP compliance with Reg. 812/2013 and Reg. 814/2013.

In order to order a special modular tank **TLR-G** use the form, present in the following pages, indicating the number and type of hydraulic connections desired and drawing their position on the schematic profile of the tank.

N.B. it is possible to add hydraulic connections **ONLY** on the cylindrical wall; our Technical Department must in any case approve every solution to assess the actual feasibility of the product and reserves the right to make/propose modifications.

WORKING CONDITIONS

	Capacity	100	200	300	500	800	1000	1500	2000	2500	3000	4000	5000
Operating pressure mod. TLR-G 2 and TLR-G 4	bar	ATM-8	ATM-8	ATM-8	ATM-8	ATM-8	ATM-8	ATM-6	ATM-6	ATM-6	ATM-6	ATM-6	ATM-6
Operating pressure mod. TLR-G 9 and TLR-G 0	bar	ATM-8	ATM-8	ATM-8	ATM-6	ATM-6	ATM-6	ATM-6	ATM-6	ATM-6	ATM-6	ATM-6	ATM-6
Operating temperature mod. TLR-G 2 and TLR-G 4	°C	-10-65	-10-65	-10-65	-10-65	-10-65	-10-65	-10-65	-10-65	-10-65	-10-65	-10-65	-10-65
Operating temperature mod. TLR-G 9	°C	-10-90	-10-90	-10-90	-10-90	-10-90	-10-90	-10-90	-10-90	-10-90	-10-90	-10-90	-10-90
Operating temperature mod. TLR-G 0	°C	AMB-99	AMB-99	AMB-99	AMB-99	AMB-99	AMB-99	AMB-99	AMB-99	AMB-99	AMB-99	AMB-99	AMB-99

REGULATORY COMPLIANCE

ErP - Reg. 812/2013 and Reg. 814/2013 | CE

European Pressure Equipment Directive (PED) 2014/68/EU, Italian Legislative Decree 26/2016 | Good engineering practice - exclusion from CE marking - Art. 4.3

16. ACCESSORIES

- | | |
|---|-----------|
| <input type="radio"/> TP - THERMOMETER Ø1/2" SMALL Ø65 mm - complete with probe socket | No. _____ |
| <input type="radio"/> TG - THERMOMETER Ø1/2" LARGE Ø100 mm - complete with probe socket | No. _____ |
| <input type="radio"/> TMS - THERMOSTAT Ø1/2" (0-90)°C | No. _____ |
| <input type="radio"/> PZ - PROBE SOCKET Ø1/2" (L=150 mm) | No. _____ |

17. TANK DIAGRAMS

FRONT VIEW

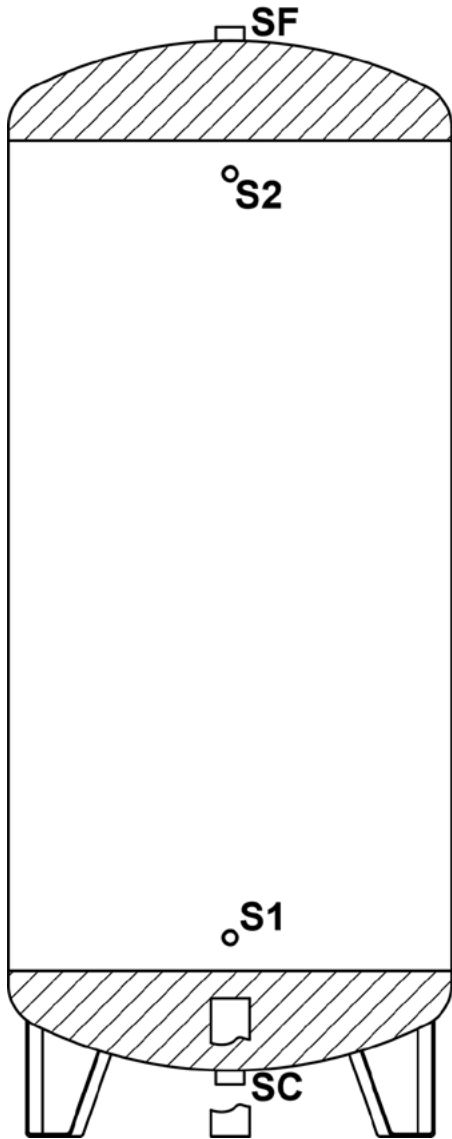

NOTE:

PLAN VIEW (from above)

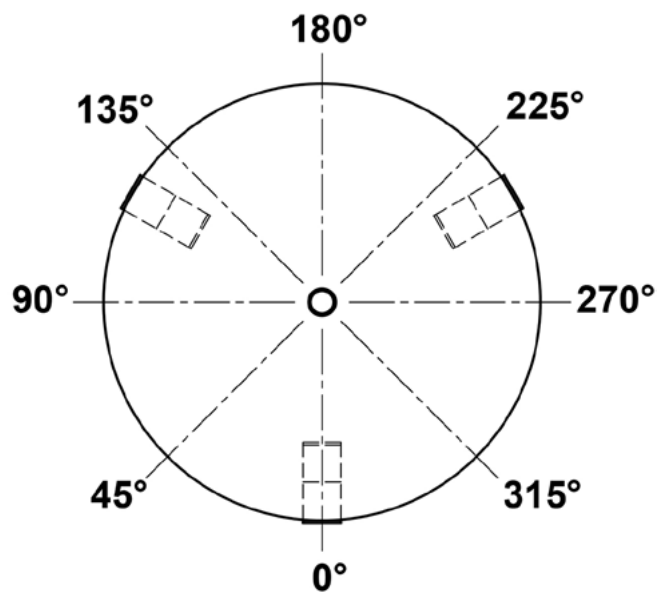

INSTRUCTIONS FOR FILLING IN FORM (FOLLOW THE POINTS INDICATED):

1. Indicate the type of tank required, placing an X in the circle to the left of the commercial code of the product (see the previous pages for the operational characteristics and the construction materials).
2. Indicate the desired capacity.
3. Indicate the maximum operating pressure.
4. Indicate the version, consulting the dimensions in the previous pages.
5. Indicate, if present, any internal accessory - not compatible with the galvanising treatment and with the domestic water versions (TLR-Z and TLR-ACS).
6. Only for TLR-ACS-S, indicate the type of anode protection in place of the standard one (sacrificial magnesium anode) and for TLR-ACS-X indicate whether the electronic anode protection is required (only solution possible on this model).
7. Indicate the quantity and type of inspection opening and show the position on the diagram below (only for TLR-ACS).
8. Indicate the quantity and type of threaded connections desired and show the position on the diagram below.
9. Indicate the quantity and type of flanged connections desired and show the position on the diagram below (it is not possible to add them to the TLR-C).
10. Indicate the quantity and type of VICTAULIC connections desired and show the position on the diagram below (it is not possible to add them to the TLR-C).
11. Indicate (only for TLR-ACS) the quantity and type of electrical resistances required, paying attention to the compatibility between the tank and the resistance (the length of the latter must not exceed the diameter of the tank without insulation).
12. Indicate the type of external cladding of the product. The external cladding in aluminium must be selected for outdoor installations.
13. Indicate (only for TLR-ACS) the quantity and type of finned copper removable heat exchangers required, paying attention to the compatibility between the tank and the heat exchanger (the length of the latter must not exceed the diameter of the tank without insulation).
14. Indicate (only for TLR-ACS) the quantity and type of tube bundle removable heat exchangers required, paying attention to the compatibility between the tank and the heat exchanger (the length of the latter must not exceed the diameter of the tank without insulation).
15. Indicate (only for TLR-ACS) the quantity and type of tube bundle removable heat exchangers required for primary steam or overheated water operation, paying attention to the compatibility between the tank and the heat exchanger (the length of the latter must not exceed the diameter of the tank without insulation).
16. Indicate the quantity and type of accessories desired. Add to the price of the accessory (unless connection S1 or S2 is used) the value of a 1/2" threaded connection from the page of the reference tank model.
17. Draw in the diagram every hydraulic connection or accessory selected, using the identification code of the item (see example).

FILL IN ALL PARTS OF THIS FORM (WHERE NECESSARY), BEFORE SENDING IT TO THE RELATIVE SALES REPRESENTATIVE FOR APPROVAL/REVISION BY OUR TECHNICAL DEPARTMENT.

WARNINGS:

1. The hydraulic connections can be added only in the cylindrical part of the tank (area without hatched line).
2. The "SC" connection CANNOT be modified, neither in diameter nor position.
3. The "S1" e "S2" connections can be moved without a surcharge only on the surface of the cylindrical part (area not hatched) and without varying the diameter.
4. The "SF" connection may be modified in terms of diameter, but not the position; for the galvanised and enamelled version, the minimum diameter is 1 1/4".
5. Each variation of diameter of the base connections (*including "SF"*) is considered as an additional connection, and the cost of the modified connection must therefore be added in its entirety.
6. Use the diagram on this page to draw the desired hydraulic connections, indicating the reference letter. The drawing is necessary in order to assess the actual feasibility of the product by the Technical Department.

FOR ANY OTHER CONFIGURATION WHICH IS NOT FEASIBLE WITH THIS FORM, CONTACT THE RELATIVE SALES REPRESENTATIVE.

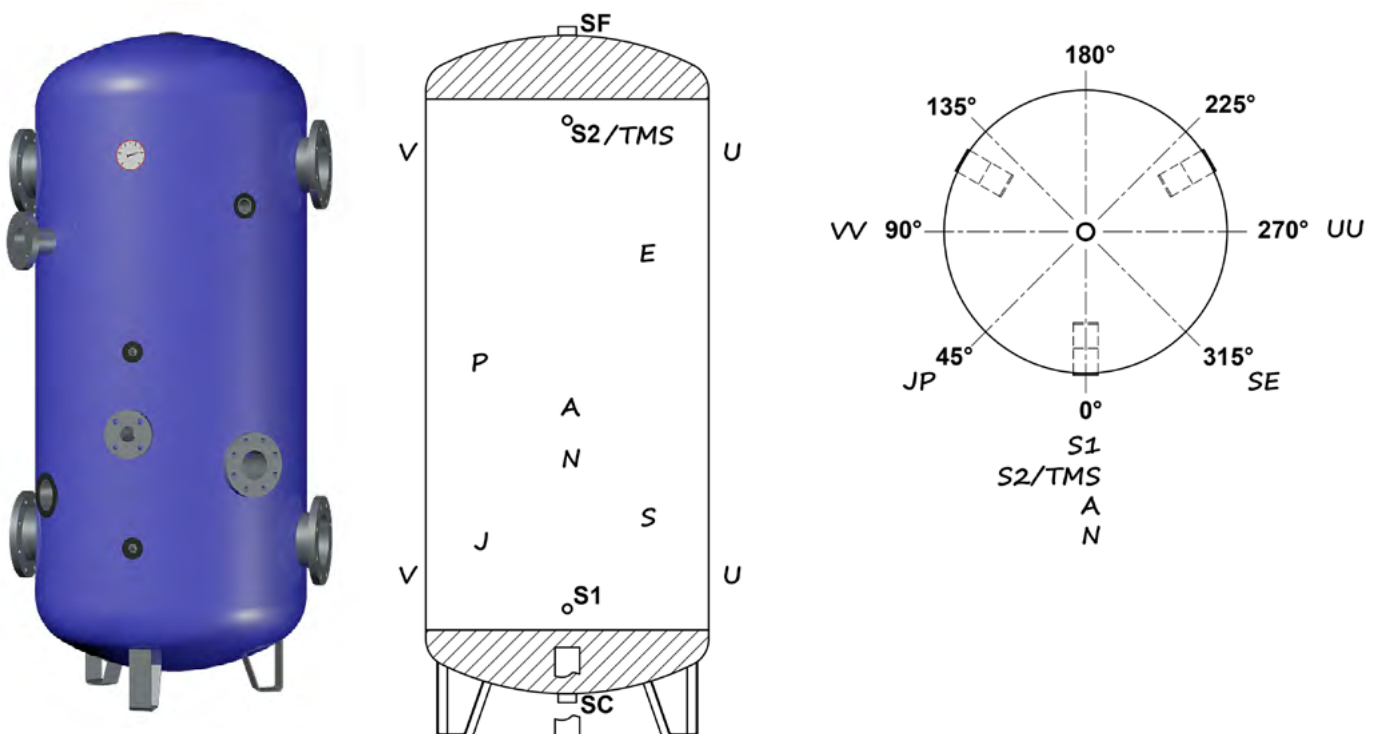
Example:

ANTI-CORROSION PROTECTION TREATMENTS

PROTECTIVE TREATMENTS FOR CARBON STEEL TANKS.

Glass-enamelling.

The glass-enamelling treatment is obtained with the application of one or two layers of enamel with characteristics of resistance to water and steam, which gives the treated product a high level of protection against the corrosion normally caused by the oxygen and the mineral salts dissolved in the water. The complete reliability of this type of treatment derives from its inorganic composition and from the link created between the enamel and the metallic surface. After baking in an oven at about 850°C according to Bayer's method and DIN 4753.3 the enamel does not absorb water and does not conduct ions, allowing the 99.9% protection of the structure of the product. The remaining 0.01% (due to possible uncovered spots) is eliminated by inserting protective anticorrosive systems into the product such as the sacrificial magnesium anodes or the permanent electronic anodes.

CERAMFLON enamelling.

The "CERAMFLON" anti-corrosion treatment is an innovative system for the protection of the metallic walls which has been introduced by the recent developments in the studies on resins, guaranteeing hygiene and many other qualities:

- it is inert and insensitive corrosion thanks to its considerable resistance to ageing;
- it is water-repellent and impermeable to steam and moisture;
- it has a practically zero absorption of humidity and the stability is maintained both at high and low temperatures, so they can withstand even very high thermal excursions;
- it has a high impact resistance and a very low friction coefficient, which avoids large and hazardous adherence phenomena which, in the majority of cases, can be attributed to limescale;
- it has a low dielectric constant which is maintained at variations in operating temperatures.

The application of the resins using triboelectric guns, carried out after careful cleaning of the support, is consolidated on the product after baking in an oven at 200°C.

Hot dip galvanising.

The corrosion treatment by hot dip galvanising in accordance with UNI EN ISO 1461 is carried out by immersion of the chemically pickled tank in a bath of molten zinc at a temperature of approximately 450°C.

PROTECTIVE TREATMENTS FOR STAINLESS STEEL TANKS.

Pickling and passivation

The calorifiers manufactured with the use of stainless steels are treated with pickling procedures with full immersion and subsequent passivation, where planned.

CATHODIC PROTECTION

The corrosion of a metal structure occurs mainly in areas in which there is the passage of current (oxidation-reduction process) from the structure towards the outside (water or gas) causing a dissolution of the structure itself.

Cathodic protection by means of magnesium anodes.

The application of sacrificial magnesium anodes is a simple and economic method to obtain a cathodic protection. The sacrificial anode creates a situation similar to an electric battery, where the electrodes are represented by the anode and the metal structure to be protected.

Since the magnesium has a dissolution voltage which is much higher than that of other metals, the corrosion will only affect the anode, which will dissolve slowly, to the advantage of the metal structure to be protected.

Given the importance of the protection of the metal against corrosion, the wear of the anode is systematically controlled and it is immediately replaced if consumed.



Cathodic protection by means of electronic impressed current system.

As an alternative to the galvanic system (coupling of materials with different potentials) there is a protection method which consists in applying an equal and opposite continuous current to the metallic structure to be protected, neutralising the voltages formed inside the tank.

Thanks to the modern techniques there is an innovative electronic system of cathodic protection with continuous impressed current.

The main advantages are:

- active protection by means of impressed currents from the outside;
- excellent flexibility of operation in order to adhere to the changeable internal coating conditions and the mass of water;
- reduction of maintenance costs due to the permanent protection of the system.



INSULATIONS

Insulating material	Removable	Thickness	Density	Thermal conductivity coefficient at 45°C	Operating temperature	Fire reaction class Euroclass EN13501-1
PLF Polyester fibre	✓	50 – 75 mm	20 kg/m³	$\lambda = 0.037 \text{ W/mK}$	Amb. / +99°C	B-s2, d0
PLFH High density polyester fibre	✓	75 – 150 mm	25 kg/m³	$\lambda = 0.034 \text{ W/mK}$	Amb. / +99°C	B-s2, d0
Hard polyurethane coverings.	✓	70 – 85 mm	40-42 kg/m³	$\lambda = 0.019 \text{ W/mK}$	Amb. / +99°C	F
Hard polyurethane injected	✗	30 – 105 mm	40-42 kg/m³	$\lambda = 0.019 \text{ W/mK}$	-10°C / +99°C	F
Expanded elastomer closed cell	✗	20 / 40 mm	30 kg/m³	$\lambda = 0.032 \text{ W/mK}$	-10°C / +90°C	C-s3, d0

PLFH / PLF – Polyester fibre

- 100% recyclable
- Environmentally compatible
- Lightweight
- Self-supporting
- Fire-retardant
- Rot-proof
- Cannot be attacked by mould, bacteria or rodents
- Hypoallergenic
- Water repellent



The raw materials consist of polyester fibres and heat-bonded co-polyester fibres, coming mainly from the recycling of plastic bottles obtained from urban waste collection.

It does not contain substances harmful to humans, may be handled and installed in complete safety, does not release powder, is hypoallergenic and cannot be attacked by microorganisms, mould and insects.

PLFH/PLF is a heat insulating product considered environmentally sustainable, even though it is not of natural origin: it is in fact recyclable and the quantity of embodied energy necessary to obtain it is extremely low.

The composition of the polyester fibre makes it an insulating material with an extremely low heat dispersion and its characteristics remain unaltered over time as it is not affected by humidity and its compact, flexible and resistant original structure is not modified.

Thanks to its characteristics, PLFH/PLF is an insulating material with the highest performance characteristics, which allows the requirements set by the severest technical standards to be satisfied, guaranteeing the maximum environmental compatibility for its entire life cycle.

Hard polyurethane.

Thermal and anti-condensation insulation made of rigid closed cell polyurethane foam (PU), free from CFC and HCFC.

It is available in various thickness and can be injected directly to the walls of the tank to eliminate the possibility of formation of condensation and guarantee the minimum thermal dispersion, or pre-formed in removable half-shells to conserve the heat accumulated in the tank.

The extremely low thermal conductivity coefficient not only allows the limits specified by the ErP reference standard to be complied with, but actually to improve on them: the tanks of the new **Q** range, thanks to the careful study of the thicknesses and of the compounds, obtain the prestigious energy class "A" due to their limited heat dispersion values.

Expanded elastomer closed cell.

Insulation with high anti-condensation properties made of closed cell expanded elastomer, CFC-free, asbestos free, odourless.

It is resistant to the diffusion of water vapour, chemical agents, mould, parasites, ozone, adverse weather conditions and UV rays.



CLADDINGS



PVC

External cladding made of coloured PVC with hinge closing, suitable for installations in locations protected against adverse weather conditions. The standard colours of each product are indicated in their construction characteristics, but different colours can be requested for each model as shown in the following table.

In the personalised TLR storage tanks the choice of the alternative colour is free of cost and does not incur any surcharge.

ITEM

ITEM	ITEM CODE
PVC COVER YELLOW RAL1023	COVER-RAL1023
PVC COVER ORANGE RAL2004	COVER-RAL2004
PVC COVER ED RAL3000	COVER-RAL3000
PVC COVER BLUE RAL5015	COVER-RAL5015
PVC COVER WHITE RAL9016	COVER-RAL9016
PVC COVER LIGHT GREY RAL7035	COVER-RAL7035
PVC COVER DARK GREY RAL7024	COVER-RAL7024
PVC COVER BLACK RAL9004	COVER-RAL9004



ALUMINIUM

External cladding made of embossed aluminium sheeting suitable also for outdoor installations. The insulations made with this type of cladding consist of panels joined together by means of rivets and extruded aluminium slats with an exclusive design, specifically designed to facilitate assembly even directly at the installation site.

The coverings and flange covers made of same material securely anchored to the insulation guarantee the same levels of quality in terms of duration and outside appearance and do not risk being damaged by the wind and adverse weather conditions.

