

NAP SLENDERLINE ACOUSTIC LOUVRES

NAP
SLENDERLINE
LOUVRES
offer high
performance in a
small package.

Introduction

The NAP Silentflo 'SLENDERLINE' range of acoustic louvres has been specifically designed for applications where the depth available is limited. Slenderline louvres are designed to fit into stud walls and partitions, ceilings and are also suitable for use on acoustic doors. They are designed to allow the transfer of air from adjacent areas without transferring unwanted noise. These units permit flow in either direction whilst reducing the transfer of noise from either side of the louvre.

They are particularly effective in the speech interference range which is known to cause issues in the office environment. As with all NAP Silentflo products they have been acoustically tested under laboratory conditions to ensure that the performance criteria are satisfied in real world conditions. Attention to detail and innovative product design are hallmarks of the NAP Silentflo product range.

Product reliability and long term durability have helped establish NAP Silentflo's reputation of proven performance and market leadership.

Applications

Offices, Schools, Laboratories, Hospitals, Hotels, Conference Venues, Hotels & Motels, Music Rooms, Apartment Buildings, Sporting Complexes, Factories, Rest Rooms, Libraries

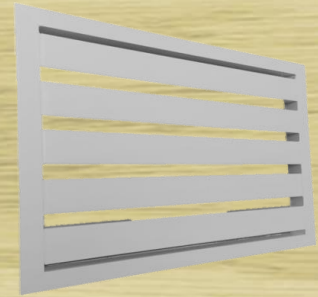

Construction

The standard 'Slenderline' louvre construction is in aluminium and is typically supplied powder coated in a range of colours and finishes. Depending on the application the louvres can also be supplied in a stainless steel or galvanised steel, with or without powder coating.

Sound absorption is provided by a high density, combustion modified and high flow resistivity acoustic foam. The foam will not shed fibres like conventional fibrous insulation materials.

The louvres include an integral fixing frame that is designed to be fixed to the face of the building element where the louvre is installed. The matching frame is then fixed to the rear side of the building element providing a neat and attractive finish.

For further information regarding the extensive range of construction materials and sizes please contact NAP Silentflo.

NAP SILENTFLO

THE EXPERTS IN NOISE CONTROL

ABN 13 071 443 886

www.nap.com.au

MELBOURNE:

23/125-127 Highbury Rd
Burwood, VIC., 3125
Phone: (03) 9572-3073
Fax: (03) 9571-6708

SYDNEY:

2/1 Powdrill Rd
Prestons, N.S.W., 2170
Phone: (02) 9712-0722
Fax: (02) 9712-0822

Represented by:

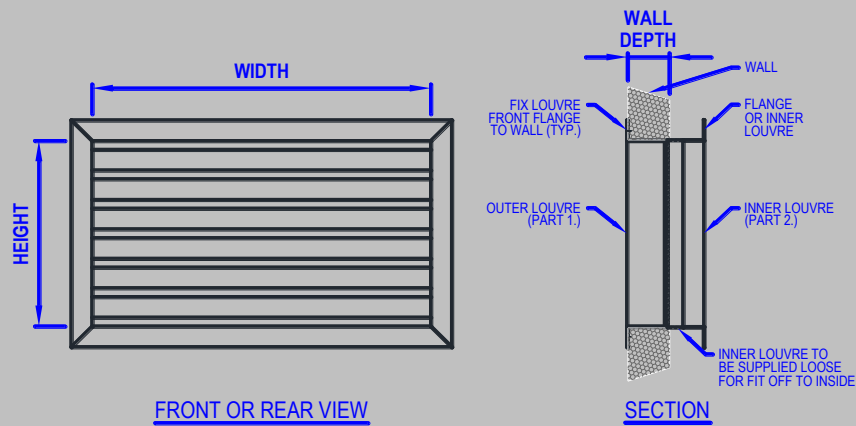

NAP SLENDERLINE ACOUSTIC LOUVRES

Performance

The performance data provided is based on tests carried out at NAP Silentflo's own test facility. The tests were designed to ensure that the performance data obtained is transferrable to real world applications. The louvres are available with either a standard foam insulation or with a metallised polyester film facing (PF version) for humid or hygienic environments.

However, it should be noted that there can be other paths of sound transmission between the source and the listener such as walls, ceilings and doors. These other sound transmission paths may affect the actual installed performance of the louvre as the transmission loss of these adjacent structures will affect the overall performance obtained in-situ. Therefore it is important that the construction of building elements adjacent to the louvre have sufficient acoustic performance to ensure that the louvre performance is not de-rated.

Noise Reduction (dB)

Model	Depth (mm)	Octave Band Centre Frequency (Hz)					
		125	250	500	1k	2k	4k
50 SL-line	50	3	7	11	13	19	22
100 SL-line	100	5	9	14	19	23	29
50 SL-line PF	50	3	7	12	14	18	21
100 SL-line PF	100	5	9	15	20	21	27

Pressure Drop

The pressure drop of the louvre can be simply calculated using the following formula:

$$\Delta p \text{ (Pa)} = K \cdot v^2$$

where Δp = pressure drop (Pa) and $K = 32$ for 50 SL-line louvre & 43 for 100 SL-line louvre
 K = loss coefficient v = the face velocity is determined by dividing the airflow (m^3/s)
 v = face velocity (m/s) by the louvre face area [$W \times H \text{ (m}^2\text{)}$]

Installation

The most common application for the NAP Silentflo 'SLENDERLINE' louvre is fitting the louvre to a wall or partition. The louvre would be installed after the construction of wall or partition and we recommend that a clearance gap of 5mm is allowed on all four sides of the louvre. This applies to the internal face area of the louvre and the louvre fixing flange will cover the gaps.

The front part of the louvre is simply placed in the opening and the louvre is fixed to wall via the perimeter flange by using suitable screw fixings. The rear part of the louvre or rear fixing flange is fitted in the same manner. If there are any gaps after fixing these should be sealed with a flexible non-setting compound.