

PURITY ULTRA



HEPA/UV SYSTEM



INDOOR AIR QUALITY

Purity Ultra address biological and particulate contaminants in indoor air. This versatile unit can be integrated into the HVAC system or operate as a stand-alone or wall-mounted system. Purity Ultra delivers hospital-level disinfection and submicron (PM 2.5) particulate removal. It is designed to significantly improve indoor air quality where it is most critical. Purity Ultra includes HEPA filtration and patent-pending onboard and remote sensors. Standard wall plug 120V/220V, 50/60Hz.

HOUSING

- Premium, easy-to-clean stainless steel



FEATURES

- Stainless steel housing
- 450 CFM blower
- Includes award-winning APCO® technology
- HEPA filtration
- Pressure sensors
- Air quality sensors allow for real-time IAQ monitoring
- High-output UVC germicidal options
- Multiple safety features & interlocks
- Quiet operation
- Medical / Industrial grade

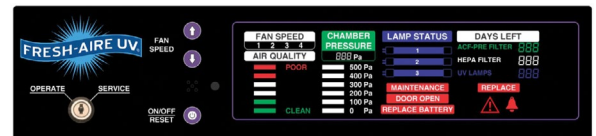

SMART LCD DISPLAY

- Fan speed indication
- Air quality indication
- Chamber pressure
- Lamp status
- Days left counter for replacement parts
- Visual and audible alarms

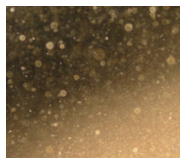

PARTICULATES

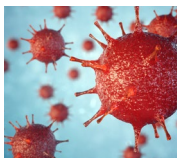

VIRUSES



BACTERIA



WALL MOUNT

PURITY ULTRA

HEPA/UV SYSTEM



UNIT DIMENSIONS

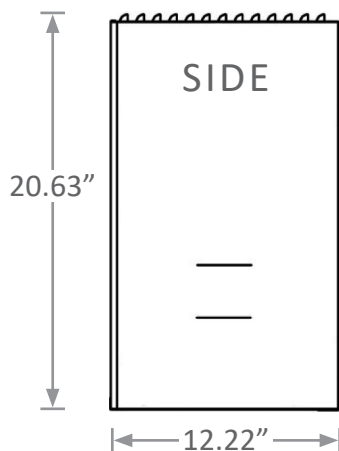
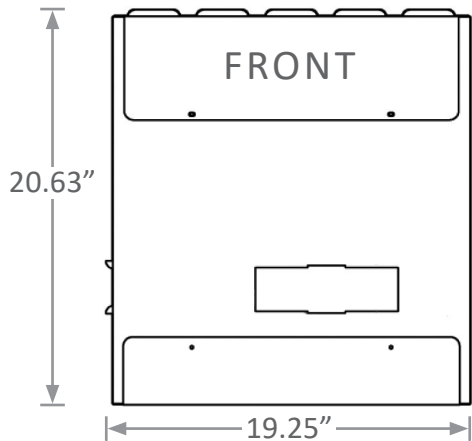

PART NUMBERS

TUV-PHE
Electric: 110 VAC

TUV-PHE-CE
Electric: 220 VAC

System Specs															
UV Lamp	Type: High-output 254 nm germicidal UV-C Life: 18000 hours														
Dimensions	Enclosure: 20 1/2"W x 19"H x 12"D														
Weight	39 lbs														
Housing	Wall-mounted with front panel access 22 gauge stainless steel														
ACF Pre-filter	Removable G4 polyester fiber activated carbon (500g) pre-filter captures larger particles and other airborne pollutants. Dimensions: 17 3/8"W x 12"H x 1 5/8"D														
HEPA Filter	Removable filter captures 99.97% of micro-organisms > 0.3µm Dimensions: 17 3/8"W x 10 3/8"H x 3 15/16"D														
Electrical	120V 50/60Hz or 220V 50/60Hz														
Fan	Adjustable speed 450 CFM UL Certified														
Remote Functions (optional)	On/off Increase/decrease fan speed														
Air Quality Sensor	Particle sensor capable of detecting fine particle sizes of approximately 1µm and larger. Detectable range of concentration is: 0 ~ 1.4mg/m3.														
Warranty	<table border="1"> <tr> <td>Housing</td> <td>5 Years</td> </tr> <tr> <td>Fan</td> <td>3 Years</td> </tr> <tr> <td>Electrical</td> <td>1 Years</td> </tr> <tr> <td>Ballast</td> <td>Lifetime</td> </tr> <tr> <td>HEPA Filter</td> <td>90 Days</td> </tr> <tr> <td>ACF Pre-filter</td> <td>90 Days</td> </tr> <tr> <td>UV Lamp(s)</td> <td>2 Year</td> </tr> </table>	Housing	5 Years	Fan	3 Years	Electrical	1 Years	Ballast	Lifetime	HEPA Filter	90 Days	ACF Pre-filter	90 Days	UV Lamp(s)	2 Year
Housing	5 Years														
Fan	3 Years														
Electrical	1 Years														
Ballast	Lifetime														
HEPA Filter	90 Days														
ACF Pre-filter	90 Days														
UV Lamp(s)	2 Year														
Replacement Part Numbers	<table border="1"> <tr> <td>ACF Pre-filter</td> <td>TUV-BNX-ACFPF</td> </tr> <tr> <td>HEPA Filter</td> <td>TUV-BNX-HF</td> </tr> <tr> <td>UV-C Lamp(s)</td> <td>TUVCL-215-HO</td> </tr> <tr> <td>Ballast</td> <td>TUV-PHE-BUV37</td> </tr> <tr> <td>Housing Stainless</td> <td>TUV-PHE-SSH</td> </tr> </table>	ACF Pre-filter	TUV-BNX-ACFPF	HEPA Filter	TUV-BNX-HF	UV-C Lamp(s)	TUVCL-215-HO	Ballast	TUV-PHE-BUV37	Housing Stainless	TUV-PHE-SSH				
ACF Pre-filter	TUV-BNX-ACFPF														
HEPA Filter	TUV-BNX-HF														
UV-C Lamp(s)	TUVCL-215-HO														
Ballast	TUV-PHE-BUV37														
Housing Stainless	TUV-PHE-SSH														
Replacement Kit Part Numbers	<table border="1"> <tr> <td>Includes: ACF PRE-Filter HEPA Filter UV-C Lamp(s)</td> <td>TUV-PHE-RK</td> </tr> </table>	Includes: ACF PRE-Filter HEPA Filter UV-C Lamp(s)	TUV-PHE-RK												
Includes: ACF PRE-Filter HEPA Filter UV-C Lamp(s)	TUV-PHE-RK														

EPA
Est. Reg. No.
075179-FL-002

WWW.FRESH-AIREUV.COM  MADE IN USA

SALES@FRESH-AIREUV.COM

800-741-1195

Cooke Industries - Phone: +64 9 579 2185 Email: sales@cookeindustries.co.nz Web: www.cookeindustries.co.nz