

The next generation condensing boilers

Light commercial models

Direct fired domestic hot water heaters

CB-85-HW

CB-105-HW

CB-125-HW

CB-155-HW



CB HW EU

CB – Light Commercial Boiler – DHW model

Available in four models: 85, 105, 125 and 155 kW

Flexible heating specialist

The CB high efficiency water heaters are the best of both worlds. No compromises. An aesthetically pleasing design combined with a robust stainless steel heat exchanger with 10 years warranty. The CB units are direct fired water heaters that can be combined with one or more storage tanks. A simple setup of one CB with one storage tank can be used for small projects, like sport facilities. With large projects like big hotels multiple CB's can be cascaded with multiple storage tanks for a high reliability and extreme high continuous hot water output during the peak demand.

Features

- ✓ Continuous flow at a dT of 30°C of more than 4300 l/h with a single water heater
- ✓ Extreme low NOx emission of less than 24 mg/kWh (2 credits under BREEAM 2018 NOx limit)
- ✓ Maximum supply temperature of 85°C
- ✓ 316L Stainless steel heat exchanger
- ✓ Up to 89,6% Water heating energy efficiency
- ✓ Compact wall hung boiler
- ✓ Full modulation of 5:1
- ✓ Cascade up to 16 boilers
- ✓ Natural or LP gas
- ✓ Easy installation and maintenance
- ✓ Also available as central heating model

State of the art PCB technology

- ✓ Clear display with graphic design
- ✓ Modbus connection standard
- ✓ Bacnet connection optional
- ✓ Easy to read fault history
- ✓ Internet and wifi connection possible



Technical specifications datasheet CB HW EU

GENERAL		CB-85-HW	CB-105-HW	CB-125-HW	CB-155-HW
Dimensions (h x w x d)	mm	845 x 440 x 530			
Water content (estimated)	liter	5,0	6,5	8,3	10,4
Weight (empty)	kg	77	79	83	86
Supply /return connection (boiler)	inch	1"	1"	1"	1 ¼"
Gas connection	inch	¾"	¾"	¾"	1"
Flue connection twin pipe	mm	100	100	100	150
Flue connection concentric pipe	mm	100/150	100/150	100/150	N.A.
WATER HEATING		Values Low fire - High fire:			
Nominal input nett G20	kW	15,4 – 81,7	18,6 – 97,3	23,6 – 119,4	35,0 – 145,3
Nominal output G20 (80-60)	kW	14,9 – 79,1	18,0 – 94,2	22,9 – 115,7	33,9 – 140,9
Nominal output G20 (50-30)	kW	16,0 – 85,1	19,5 – 101,8	24,7 – 124,7	36,4 – 151,0
Turndown ratio	1:x	5	5	5	4
Load profile ¹	-	3XL	3XL	3XL	4XL
Water heating energy efficiency (η _{wh})	%	85,9%	85,6%	89,6%	89,1%
GAS CONSUMPTION		Values Low fire - High fire:			
G20	m ³ /h	1,6 – 8,5	1,9 – 10,2	2,5 – 12,5	3,7 – 15,3
G31	m ³ /h	0,6 – 3,2	0,8 – 3,9	1,0 – 4,8	1,6 – 5,7
Gas supply pressure nominal	G20	mbar	20		
	G31	mbar	37		
EMISSION					
NO _x class	-	6			
Nitrogen Dioxide Emission (NO _x) ²	mg/kWh	23,1	20,1	23,9	20,1
Flue gas temperature at combustion air temperature of 20 °C	°C	60 - 90			
Available pressure for the flue system ³	Pa	200			
Noise level	dB(A)	65,8	68,0	67,8	73,0
INSTALLATION					
Maximum supply temperature	°C	85			
Resistance water heater ΔT = 17 °C	mWc	5,5	5,7	5,5	5,1
Maximum water pressure	bar	8,0			
ELECTRIC					
Maximum power consumption	W	190	280	280	280
Power supply	V/Hz	230 / 50			
Protection class	-	IPX4D			
NOTES					
¹	Load profile when combining the water heater with a storage tank of at least 300 liter				
²	These numbers are used to assign two credits according to the BREEAM 2018 standards				
³	Maximum allowed combined resistance of flue gas and air supply piping at high fire				

Technical specifications EWD Storage tanks

GENERAL		EWD300	EWD500	EWD750
Volume (V)	liter	304	491	765
Weight	kg	55	76	131
Diameter	mm	675	795	995
Height	mm	1804	2020	1866
Insulation type	-	Neopor	Neopor	NeoDUL
Insulation thickness	mm	85	95	100
Energy efficiency class	-	B	B	C
Standing loss (EN 12897)	Watt	63	75	104

Code	Connection
A	Return to water heater
B	Flow from water heater
C	Cold water inlet
D	DHW outlet
E	Free connection (T&P valve)
F	Circulation return
G	Bleed valve
H	Thermometer connection

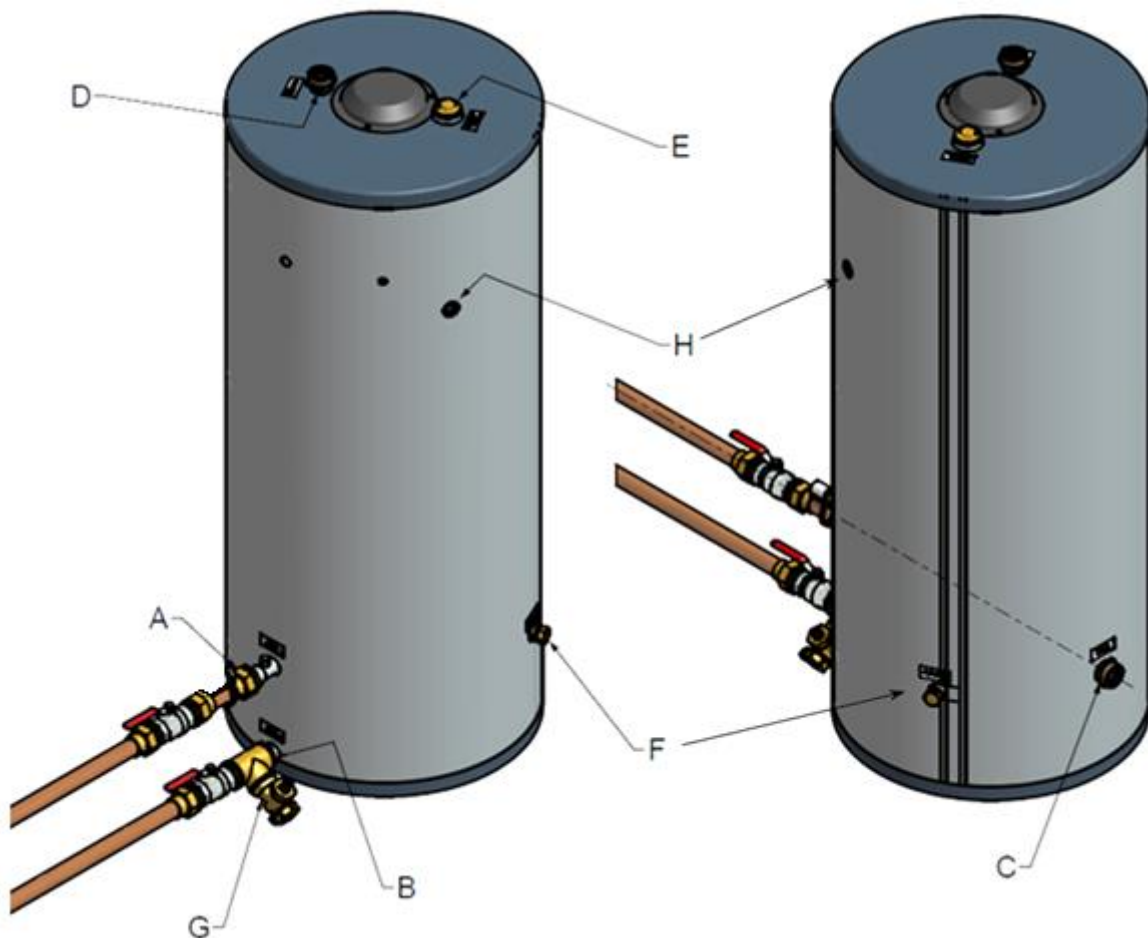

The EWD300, EWD500 and EWD750 are supplied including an already assembled slice sensor. This sensor is placed near the return connection and is directly glued to the tank behind the insulation.

Domestic hot water tap data

TAP DATA AT $\Delta T = 28^{\circ}\text{C}$		CB-85-HW	CB-105-HW	CB-125-HW	CB-155-HW
Continuous $\Delta T = 28^{\circ}\text{C}$	l / min	44	52	64	77
Continuous $\Delta T = 28^{\circ}\text{C}$	l / h	2620	3130	3830	4640
300 l tank, $\Delta T = 28^{\circ}\text{C}$, 30 min.	l	1610	1865	2215	2620
300 l tank, $\Delta T = 28^{\circ}\text{C}$, 60 min.	l	2920	3430	4130	4940
300 l tank, $\Delta T = 28^{\circ}\text{C}$, 90 min.	l	4230	4995	6045	7260
300 l tank, $\Delta T = 28^{\circ}\text{C}$, 120 min.	l	5540	6560	7960	9580
500 l tank, $\Delta T = 28^{\circ}\text{C}$, 30 min.	l	1810	2065	2415	2820
500 l tank, $\Delta T = 28^{\circ}\text{C}$, 60 min.	l	3120	3630	4330	5140
500 l tank, $\Delta T = 28^{\circ}\text{C}$, 90 min.	l	4430	5195	6245	7460
500 l tank, $\Delta T = 28^{\circ}\text{C}$, 120 min.	l	5740	6760	8160	9780
750 l tank, $\Delta T = 28^{\circ}\text{C}$, 30 min.	l	2060	2315	2665	3070
750 l tank, $\Delta T = 28^{\circ}\text{C}$, 60 min.	l	3370	3880	4580	5390
750 l tank, $\Delta T = 28^{\circ}\text{C}$, 90 min.	l	4680	5445	6495	7710
750 l tank, $\Delta T = 28^{\circ}\text{C}$, 120 min.	l	5990	7010	8410	10030
1000 l tank, $\Delta T = 28^{\circ}\text{C}$, 30 min.	l	2310	2565	2915	3320
1000 l tank, $\Delta T = 28^{\circ}\text{C}$, 60 min.	l	3620	4130	4830	5640
1000 l tank, $\Delta T = 28^{\circ}\text{C}$, 90 min.	l	4930	5695	6745	7960
1000 l tank, $\Delta T = 28^{\circ}\text{C}$, 120 min.	l	6240	7260	8660	10280

TAP DATA AT $\Delta T = 30^{\circ}\text{C}$		CB-85-HW	CB-105-HW	CB-125-HW	CB-155-HW
Continuous $\Delta T = 30^{\circ}\text{C}$	l / min	41	49	60	72
Continuous $\Delta T = 30^{\circ}\text{C}$	l / h	2440	2920	3580	4330
300 l tank, $\Delta T = 30^{\circ}\text{C}$, 30 min.	l	1520	1760	2090	2465
300 l tank, $\Delta T = 30^{\circ}\text{C}$, 60 min.	l	2740	3220	3880	4630
300 l tank, $\Delta T = 30^{\circ}\text{C}$, 90 min.	l	3960	4680	5670	6795
300 l tank, $\Delta T = 30^{\circ}\text{C}$, 120 min.	l	5180	6140	7460	8960
500 l tank, $\Delta T = 30^{\circ}\text{C}$, 30 min.	l	1720	1960	2290	2665
500 l tank, $\Delta T = 30^{\circ}\text{C}$, 60 min.	l	2940	3420	4080	4830
500 l tank, $\Delta T = 30^{\circ}\text{C}$, 90 min.	l	4160	4880	5870	6995
500 l tank, $\Delta T = 30^{\circ}\text{C}$, 120 min.	l	5380	6340	7660	9160
750 l tank, $\Delta T = 30^{\circ}\text{C}$, 30 min.	l	1970	2210	2540	2915
750 l tank, $\Delta T = 30^{\circ}\text{C}$, 60 min.	l	3190	3670	4330	5080
750 l tank, $\Delta T = 30^{\circ}\text{C}$, 90 min.	l	4410	5130	6120	7245
750 l tank, $\Delta T = 30^{\circ}\text{C}$, 120 min.	l	5630	6590	7910	9410
1000 l tank, $\Delta T = 30^{\circ}\text{C}$, 30 min.	l	2220	2460	2790	3165
1000 l tank, $\Delta T = 30^{\circ}\text{C}$, 60 min.	l	3440	3920	4580	5330
1000 l tank, $\Delta T = 30^{\circ}\text{C}$, 90 min.	l	4660	5380	6370	7495
1000 l tank, $\Delta T = 30^{\circ}\text{C}$, 120 min.	l	5880	6840	8160	9660

TAP DATA AT $\Delta T = 40^{\circ}\text{C}$		CB-85-HW	CB-105-HW	CB-125-HW	CB-155-HW
Continuous $\Delta T = 40^{\circ}\text{C}$	l / min	31	37	45	54
Continuous $\Delta T = 40^{\circ}\text{C}$	l / h	1830	2190	2680	3250
300 l tank, $\Delta T = 40^{\circ}\text{C}$, 30 min.	l	1215	1395	1640	1925
300 l tank, $\Delta T = 40^{\circ}\text{C}$, 60 min.	l	2130	2490	2980	3550
300 l tank, $\Delta T = 40^{\circ}\text{C}$, 90 min.	l	3045	3585	4320	5175
300 l tank, $\Delta T = 40^{\circ}\text{C}$, 120 min.	l	3960	4680	5660	6800
500 l tank, $\Delta T = 40^{\circ}\text{C}$, 30 min.	l	1415	1595	1840	2125
500 l tank, $\Delta T = 40^{\circ}\text{C}$, 60 min.	l	2330	2690	3180	3750
500 l tank, $\Delta T = 40^{\circ}\text{C}$, 90 min.	l	3245	3785	4520	5375
500 l tank, $\Delta T = 40^{\circ}\text{C}$, 120 min.	l	4160	4880	5860	7000
750 l tank, $\Delta T = 40^{\circ}\text{C}$, 30 min.	l	1665	1845	2090	2375
750 l tank, $\Delta T = 40^{\circ}\text{C}$, 60 min.	l	2580	2940	3430	4000
750 l tank, $\Delta T = 40^{\circ}\text{C}$, 90 min.	l	3495	4035	4770	5625
750 l tank, $\Delta T = 40^{\circ}\text{C}$, 120 min.	l	4410	5130	6110	7250
1000 l tank, $\Delta T = 40^{\circ}\text{C}$, 30 min.	l	1915	2095	2340	2625
1000 l tank, $\Delta T = 40^{\circ}\text{C}$, 60 min.	l	2830	3190	3680	4250
1000 l tank, $\Delta T = 40^{\circ}\text{C}$, 90 min.	l	3745	4285	5020	5875
1000 l tank, $\Delta T = 40^{\circ}\text{C}$, 90 min.	l	4660	5380	6360	7500

Domestic hot water tap data

TAP DATA AT $\Delta T = 50^{\circ}\text{C}$		CB-85-HW	CB-105-HW	CB-125-HW	CB-155-HW
Continuous $\Delta T = 50^{\circ}\text{C}$	l / min	24	29	35	42
Continuous $\Delta T = 50^{\circ}\text{C}$	l / h	1430	1710	2100	2540
300 l tank, $\Delta T = 50^{\circ}\text{C}$, 30 min.	l	1015	1155	1350	1570
300 l tank, $\Delta T = 50^{\circ}\text{C}$, 60 min.	l	1730	2010	2400	2840
300 l tank, $\Delta T = 50^{\circ}\text{C}$, 90 min.	l	2445	2865	3450	4110
300 l tank, $\Delta T = 50^{\circ}\text{C}$, 120 min.	l	3160	3720	4500	5380
500 l tank, $\Delta T = 50^{\circ}\text{C}$, 30 min.	l	1215	1355	1550	1770
500 l tank, $\Delta T = 50^{\circ}\text{C}$, 60 min.	l	1930	2210	2600	3040
500 l tank, $\Delta T = 50^{\circ}\text{C}$, 90 min.	l	2645	3065	3650	4310
500 l tank, $\Delta T = 50^{\circ}\text{C}$, 120 min.	l	3360	3920	4700	5580
750 l tank, $\Delta T = 50^{\circ}\text{C}$, 30 min.	l	1465	1605	1800	2020
750 l tank, $\Delta T = 50^{\circ}\text{C}$, 60 min.	l	2180	2460	2850	3290
750 l tank, $\Delta T = 50^{\circ}\text{C}$, 90 min.	l	2895	3315	3900	4560
750 l tank, $\Delta T = 50^{\circ}\text{C}$, 120 min.	l	3610	4170	4950	5830
1000 l tank, $\Delta T = 50^{\circ}\text{C}$, 30 min.	l	1715	1855	2050	2270
1000 l tank, $\Delta T = 50^{\circ}\text{C}$, 60 min.	l	2430	2710	3100	3540
1000 l tank, $\Delta T = 50^{\circ}\text{C}$, 90 min.	l	3145	3565	4150	4810
1000 l tank, $\Delta T = 50^{\circ}\text{C}$, 120 min.	l	3860	4420	5200	6080

TAP DATA AT $\Delta T = 65^{\circ}\text{C}$		CB-85-HW	CB-105-HW	CB-125-HW	CB-155-HW
Continuous $\Delta T = 65^{\circ}\text{C}$	l / min	18	21	26	31
Continuous $\Delta T = 65^{\circ}\text{C}$	l / h	1050	1250	1530	1860
300 l tank, $\Delta T = 65^{\circ}\text{C}$, 30 min.	l	825	925	1065	1230
300 l tank, $\Delta T = 65^{\circ}\text{C}$, 60 min.	l	1350	1550	1830	2160
300 l tank, $\Delta T = 65^{\circ}\text{C}$, 90 min.	l	1875	2175	2595	3090
300 l tank, $\Delta T = 65^{\circ}\text{C}$, 120 min.	l	2400	2800	3360	4020
500 l tank, $\Delta T = 65^{\circ}\text{C}$, 30 min.	l	1025	1125	1265	1430
500 l tank, $\Delta T = 65^{\circ}\text{C}$, 60 min.	l	1550	1750	2030	2360
500 l tank, $\Delta T = 65^{\circ}\text{C}$, 90 min.	l	2075	2375	2795	3290
500 l tank, $\Delta T = 65^{\circ}\text{C}$, 120 min.	l	2600	3000	3560	4220
750 l tank, $\Delta T = 65^{\circ}\text{C}$, 30 min.	l	1275	1375	1515	1680
750 l tank, $\Delta T = 65^{\circ}\text{C}$, 60 min.	l	1800	2000	2280	2610
750 l tank, $\Delta T = 65^{\circ}\text{C}$, 90 min.	l	2325	2625	3045	3540
750 l tank, $\Delta T = 65^{\circ}\text{C}$, 120 min.	l	2850	3250	3810	4470
1000 l tank, $\Delta T = 65^{\circ}\text{C}$, 30 min.	l	1525	1625	1765	1930
1000 l tank, $\Delta T = 65^{\circ}\text{C}$, 60 min.	l	2050	2250	2530	2860
1000 l tank, $\Delta T = 65^{\circ}\text{C}$, 90 min.	l	2575	2875	3295	3790
1000 l tank, $\Delta T = 65^{\circ}\text{C}$, 120 min.	l	3100	3500	4060	4720

Installation schematics

Single water heater with a single storage tank

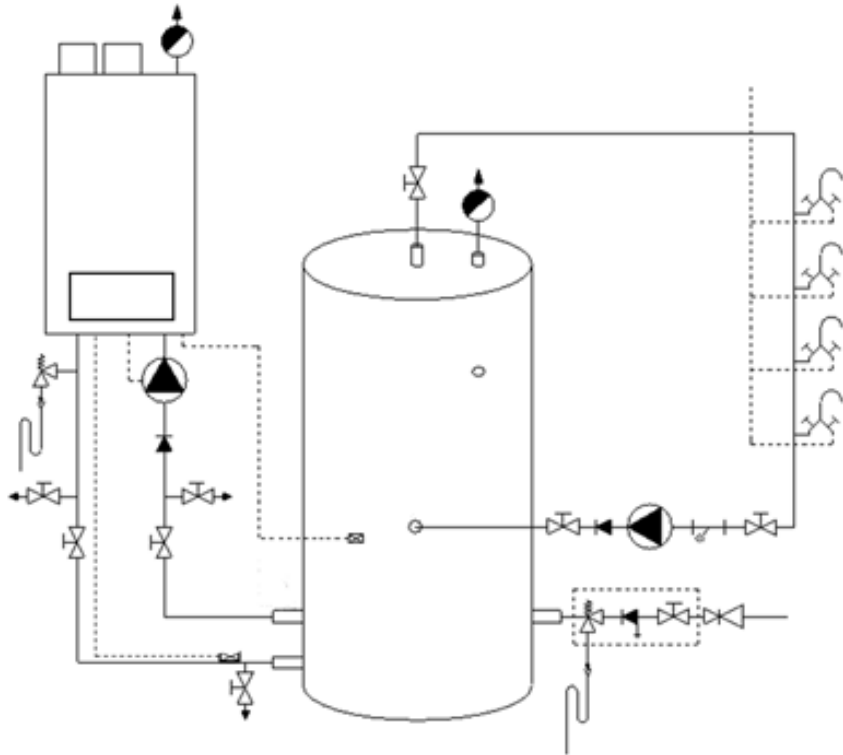

	PUMP
	NON- RETURN VALVE
	VALVE
	SAFETY VALVE
	AUTOMATIC AIR VENT
	FILTER
	INLET COMBINATION - Overflow - Controllable Inlet valve - Valve
	PRESSURE REGULATING VALVE

Three water heaters with two storage tanks

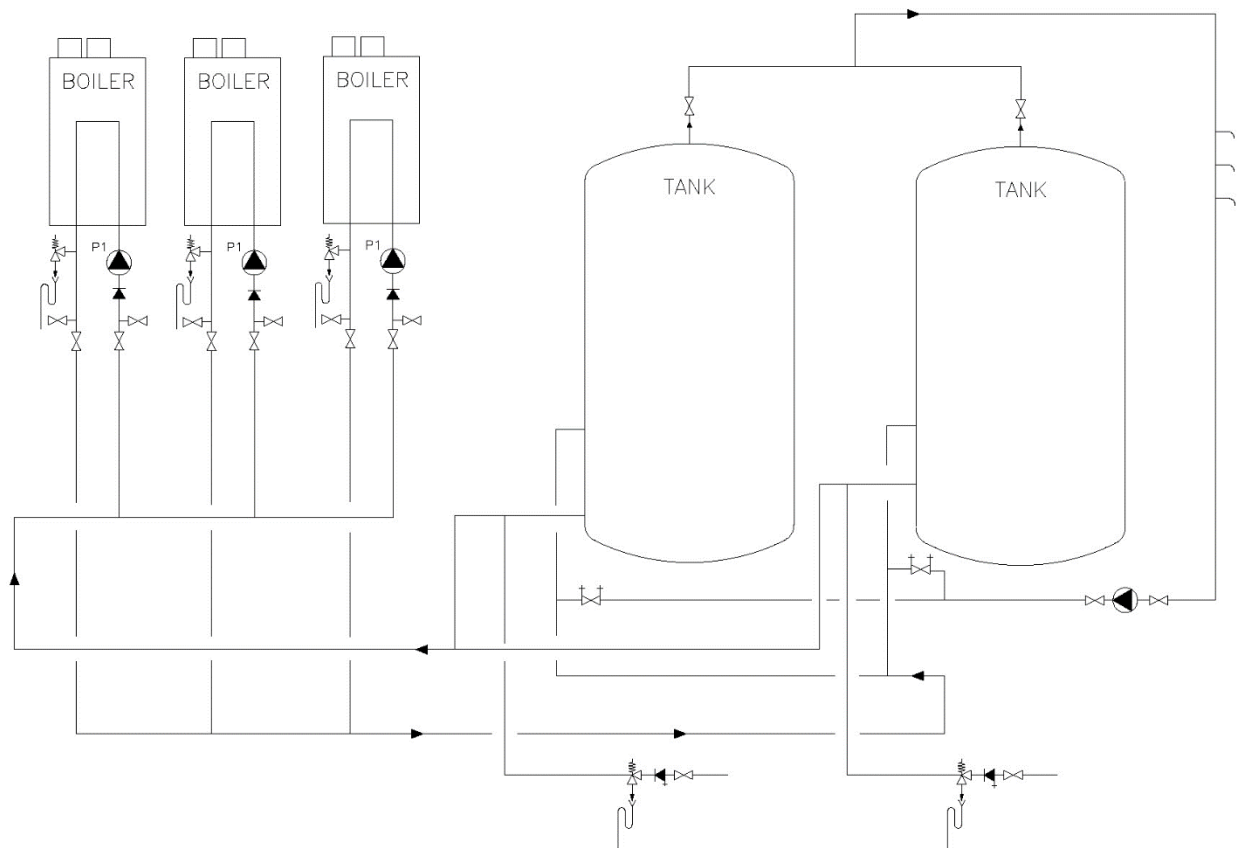

Equipment and terminal connections of CB models

Standard boiler equipment

- ✓ Flip over panel with boiler control and display
- ✓ Graphic display with easy to use controls
- ✓ On/off power switch
- ✓ Laptop computer connection
- ✓ Supply and return water temperature sensors
- ✓ Integrated pressure sensor
- ✓ Flue gas temperature sensor
- ✓ Burner door temperature sensor
- ✓ Real wall temperature sensor
- ✓ Integrated flue gas check valve (non-return valve)
- ✓ Venturi system for steady gas/air mixture
- ✓ Full stainless steel heat exchanger
- ✓ Premix burner
- ✓ Internal automatic air vent with drain connection
- ✓ Stainless steel cabinet with light weight molded removable front door and removable side panels for easy access
- ✓ Fully serviceable from the front of the boiler
- ✓ Sealed boiler cabinet reduces chances for debris entering the premix fan
- ✓ Integrated low water cutoff
- ✓ Condensate trap
- ✓ Twin pipe or concentric air inlet and flue gas outlet connection
- ✓ External ignition transformer connection

High voltage connections

- ✓ Water heater pump
- ✓ Alarm

Low voltage connections

- ✓ System temperature sensor
- ✓ DHW temperature sensor
- ✓ Modbus
- ✓ Cascade connection
- ✓ External low water cutoff safety
- ✓ Gas pressure switch safety
- ✓ Universal safety contact set 1
- ✓ Universal safety contact set 2



Features and benefits

Boiler control

- ✓ Large backlit LCD screen with easy to read full text information, programming and errors



Cabinet

- ✓ Removable stainless steel side panels for easy access
- ✓ Compact design with small footprint
- ✓ Light weight design for wall hung applications
- ✓ Narrow width of 44 cm that fits through doorways

Pump controls

- ✓ PWM control for variable speed pumps
- ✓ Water heater pump

Additional features

- ✓ Two level frost protection
- ✓ Short cycle protection
- ✓ Adjustable minimum and maximum power
- ✓ Temperature boost function
- ✓ Multiple levels of security
- ✓ Field convertible to LPG
- ✓ Maximum flow temperature of 85°C
- ✓ Water heater pressure up to 8 bar
- ✓ Extreme low NOx emission of less than 24 mg/kWh with all models
- ✓ Turn down ratio of 1:5

External control and BMS options

- ✓ Modbus connection standard
- ✓ IP module for remote access available
- ✓ Anti-legionella program

Cascade program options

- ✓ Integrated cascade control
- ✓ Cascade control of up to 16 boilers
- ✓ Remote operation and heat demand indication from each boiler
- ✓ Four cascade power program modes
- ✓ Boiler sequencing and rotation control

Data logging

- ✓ Error logging with time and date stamp
- ✓ Water heater history logging
- ✓ Real time and date clock
- ✓ Days of operation
- ✓ Heating burner runtime hours
- ✓ DHW burner runtime hours
- ✓ Successful ignition attempts
- ✓ Failed ignition attempts
- ✓ Flame failures
- ✓ Last 15 lockout errors
- ✓ Hours since last service
- ✓ Hours until next service
- ✓ Total days of boiler operation



P.O. Box 5145
9700 GC Groningen
The Netherlands



Rigaweg 10
9723 TH Groningen
The Netherlands



T + 31 50 547 04 70
sales@ecohs.nl
www.ecohs.nl