

Radial Fans

Double Inlet

FORWARD AND BACKWARD CURVED



comefri

comefri Radial Fans

	Page
General information of the series TLZ, THLZ	2-8
1. Fan Construction	2
2. Fan Accessories	6
3. Motor Selection	8
<hr/>	
4. Technical Information	9-12
4.1 General	9
4.2 Information on Sound Power Levels	9
4.3 Explanation of Performance Curves	10
4.3.1 Example of selection for TLZ	11
4.3.2 Example of selection for THLZ	12
<hr/>	
5. Performance Curves	13-38
<hr/>	
6. Dimensions and Weights	
6.1 Dimensions TLZ 160 ÷ 710, TLZ 200 R ÷ 710 R	39
6.2 Dimensions TLZ 710 T ÷ 1000 T	40
6.3 Dimensions THLZ 180 ÷ 450, THLZ 200 R ÷ 450 R	41
6.4 Dimensions of Fan Side Plates	42
6.5 Weights of Fans	42
<hr/>	
7. Fan Discharge Positions and Accessories	43
<hr/>	
8. Example for Ordering	44
<hr/>	

Note:

This catalogue has to be used only for pre-selections. A detailed selection is available from our AEOLUS PLUS selection program

comefri Radial Fans

have been designed specially for ventilation and air conditioning units. They offer the following advantages to the unit manufacturer:

- compact design for space saving installations
- high efficiency operation for economic running costs
- low operational noise levels and vibration free running
- wide volume range and high pressure development
- designed for flexible applications and temperature range of -30°C to +80°C
- fans TLZ THLZ all dimensionally interchangeable
- standardized components sized in accordance with R20 DIN 323
- superb quality
- short delivery from stock warehouses
- prices to meet your budget

COMEFRI double inlet fans are available in the following range with dimensionally identical casings

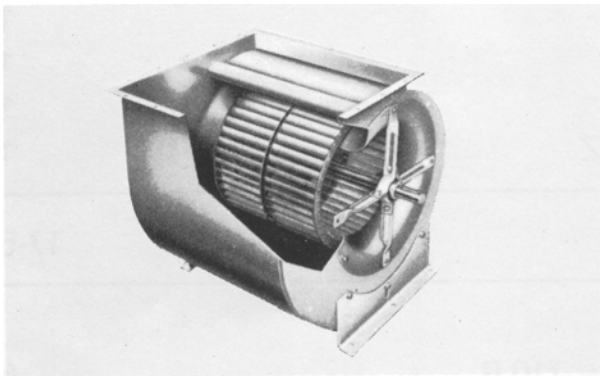

Pic 1
Type TLZ
High capacity and efficiency
Fan with forward curved impeller

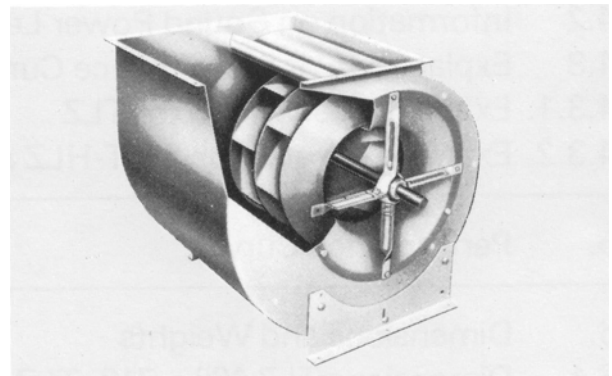

Pic 2
Type THLZ
High capacity and efficiency
Fan with backward curved impeller

Forward and backward curved fans are engineered to identical dimensions for interchangeability.

Fan inlet diameters are the same, as impeller diameter.

Although the fans have the same external dimensions size to size, their performance curves vary significantly due to the different impeller design.

1. Fan Construction

1.1 Casings

All fan casings to size 1000 are manufactured from high quality galvanized steel.

Pic 3
System of locking side plates to scroll by «Pittsburgh» seam



Series TLZ size 160 up to 400 and THLZ 180 to 400

The casings are manufactured with Pittsburgh seams as described above. This system gives great strength as well as ensuring leak proof joints. Predrilled holes are located in the side plates to take either feet or frames as accessories. These are supplied extra.

Pic 4
Fan casing of Fan types
TLZ 450 to 710 and THLZ 450

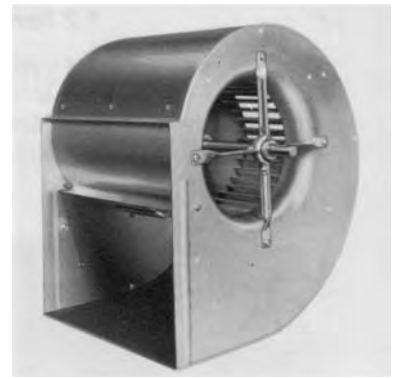

Series TLZ 450 to 710 and THLZ size 450

All casings are manufactured with Pittsburgh seams as described above and on the inside of the side plates nuts are applied enabling easy fixing of feet or frames by standard metric bolts, supplied as extra.

Pic 5
Fan casing of Fan Type TLZ.
The series T bearing arrangement is shown
necessitating the frame to be supplied as an
integral part of the unit.



Serie TLZ size 710 to 1000

Fans are supplied with integral bearing frames and cast iron plummer block bearings housings.

1.2 Fan Inlets

To ensure high efficiency, fans are supplied with aerodynamically shaped fan inlets. These nozzles form part of the side casing on the TLZ fans. On fan series THLZ, the inlet cones are separate pieces, bolted to the sideplate.

1.3 Impellers

COMEFRI high efficiency impellers are specially designed to give high volume and pressures whilst maintaining smooth vibration free running. Even at high peripheral speeds the fans are stable. Fan impellers are statically and dynamically balanced, in accordance with VDI 2060 and ISO 1940/1, grade G 6.3. Impeller diameters are in series R20 according to DIN 323.



Pic 6
High efficiency impeller with forward curved
impellers type TLZ.

COMEFRI Fan series TLZ

These fans are supplied with forward curved impellers manufactured in galvanized sheet steel. The impellers are designed for maximum efficiency to latest technology. Impeller blades are mounted on to a common backplate and locked onto a holding shroud. A substantial aluminium hub is rigidly connected to the backplate and precision machined to receive the fan shaft.

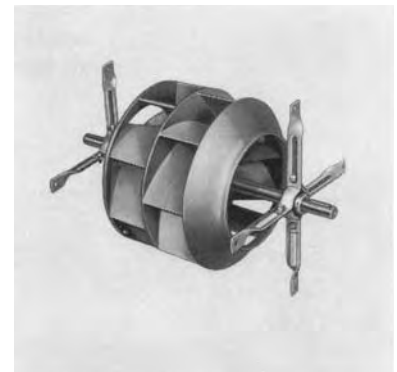

Pic 7
High efficiency impeller with backward curved
blades type THLZ.

COMEFRI Fan series THLZ

These fans are supplied with high efficiency non-overloading impellers having backward curved blades. The blade shape results from research at our test laboratory and is specially designed to give high volume and pressure characteristics at high efficiency. Impellers sizes 180 to 450 are manufactured in glass reinforced polyamid whereas fans above this size are made from high quality mild steel. These impellers are of welded construction and painted.

1.4 Shafts

Shafts are manufactured from high quality steel, keywayed at both ends and at the impeller location point.

1.5 Bearings

All fans are supplied as standard with pre-greased sealed-for-life ball bearings. These are always inspected prior to assembly to ensure quiet running. Bearings have an L_{10} life of 20,000 HRS at peak performance. Limiting values for speed and power are indicated on the characteristic curves and should not be exceeded. Pulleys should be mounted close to the fan bearing. The various bearing types are described as follows.

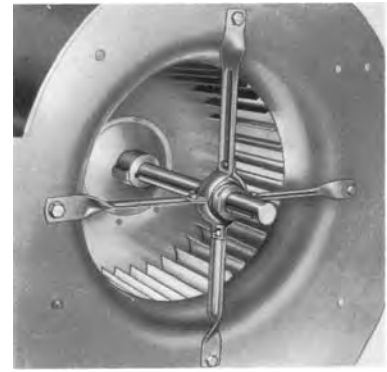

Pic 8
Bearings of Radial Fans series TLZ size 160 up to 710.

Series TLZ size 160 to 710

Sealed-for-life bearings are located in formed support arms made from galvanised steel. The bearing race is mounted in a unique rubber anti-vibration housing which provides for sound insulation and smooth running (Pic 8).

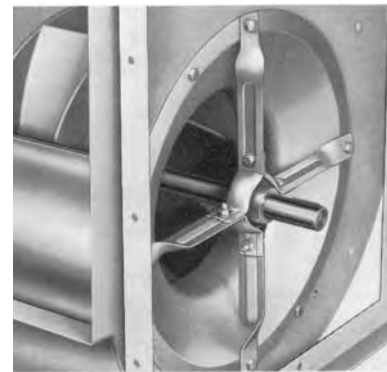

Pic 9
Bearings of Radial Fans series THLZ size 180 to 450.

Series THLZ size 180 to 450

Bearings are similar to TLZ and are located with clamp collars (Pic 9).

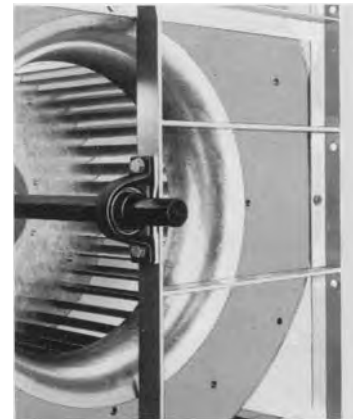

Pic 10
Bearing of Fan series TLZ 710 T to 1000 T.

Series TLZ 710 T to 1000 T

Plummer blacks containing self aligning ball journals are used in this range. The bearing being mounted onto the substantial fan frame (Pic 10).

2. Accessories

All fan can be supplied with the following accessories:



Pic 11
Radial Fan Type THLZ 450 with feet.

2.1 Feet ...F

Manufactured from galvanized sheet steel. The predrilled fan feet are supplied separately with necessary fixing screws. Feet are available from fan size 160 to 710.



Pic 12
Radial Fan Type TLZ 500 with outlet flange and frame.

2.2 Outlet Flanges ...A

On TLZ fans to size 710 the outlet flanges can be supplied separately or fitted to customer requirement. They are manufactured from galvanized steel and drilled as the dimension sheets.

2.3 Fan Mounting Frames ...R

From size 200 to 710, separate fan frames are available as an alternative method of mounting.



Pic 13
Radial Fan Type THLZ 225 complete with outlet flange, inspection door and condensation drain.

2.4 Inspection door

Can be fitted to the fan casing and consist in a galvanized steel plate fixed by quick release screws. Gaskets prevent leakage. For inspection door positions see section 7 and 8.

2.5 Drain Plugs

Can be fitted at lowest point of the fan casing to drain condensation. Plugs are 3/8" gas thread and can be located in positions described in section 7 and 8.

Accessory ordering should always indicate the position required as detailed in 7.2.

2.6 Anti-spark features

When selecting and installing fans for hazardous applications the relevant standards must be considered as sparking can occur from the following conditions:

- Contact sparking
- Heat build-up
- Build-up of electro-static

Consideration should also be given to the following:

Zone 0:

fans are not suitable for this application.

Zone 1 :

(Sub group G1-G3). Selection of fans in this category should take into consideration the following:

- the max fan speed should be reduced by 20%
- the max shaft power should be reduced by 30%
- fans should only be selected for applications where the shaft is horizontal
- guards should have a mesh size of no more than 12 mm.
- design life of bearings at duty point should be 40000 hours minimum
- driving ropes of the anti-static type should only be used

Zone 2:

standard fans described in this catalogue are suitable.

To avoid sparking the following combinations of materials can be used:

- steel with copper or brass
- stainless steel with stainless steel

2.7 Inlet vane control



Pic 14
Inlet vane control.

Volume regulation can be achieved by using the **COMEFRI** inlet vane control, see fig.14 and 15. This energy saving device can be supplied as an integral part of THLZ fans from size 315. A special selection chart is available which is for use with standard performance charts.

The vane controller comprises a set of adjustable radial vanes mounted inside the inlet nozzle. The vanes when set to the required angle regulate the volume whilst directing the air into the impeller blade. The result is a considerable saving in motor power. All moving components are located inside the fan with linkage to the outside to facilitate the adjustment of the control by either electric or pneumatic actuator.

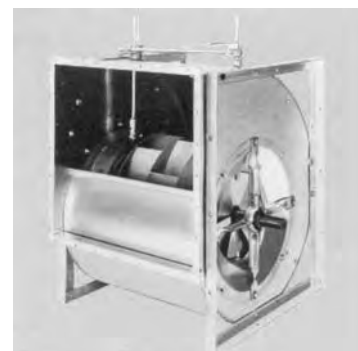

Pic 15
Inlet vane control fitted to fan THLZ 450 R.

3. Motor Selection

The following safety margins should be added to the power requirements at the fan shaft as shown by the performance curves.

Rating	TLZ	THLZ
up to 10 kW	20%	15%
over 10 kW	12%	12%

This safety margin compensates for transmission losses of the V-belt drive and for possible minor inaccuracies in the calculation of the system resistance. When selecting the suitable motor special attention should be paid to the fact that if the acceleration time of the fan is longer than the maximum acceleration time of the motor the trip time of the motor starter overload must be increased or a larger motor or starter for heavy duty starting must be used.

The acceleration time can be calculated from:

a) in case of direct starting:

$$t_a \approx 1,5 \cdot 10^{-5} \frac{J \cdot n^2}{P_M}$$

Where :

t_a [s] - acceleration time

J [kgm²] - mass moment of inertia, $J = m \cdot r^2 (\approx \frac{G \cdot D^2}{4})$

n [min⁻¹] - nominal speed of the fan

P_M [kW] - motor rating

b) in case of λ / Δ starting, the acceleration time compared with direct starting is 5.5 times longer .

4. Technical Explanations

4.1 General

The formulae, signs and SI-units used in this catalogue correspond to the standards DIN 1301, DIN 1345, DIN 45635 and to the Eurovent-Recommendations 0/1 and 1/1.

Standard operating conditions for the fan performance curves:

$$\rho_{\text{air}} = 1.2 \text{ kg/m}^3 \text{ (at 1013 mbar and 293 K (= 20°C))}$$

4.2 Sound Levels

The measurement of noise levels are taken according to DIN 45635. For this purpose a harmonic analyzer type 2107 and Herz-Octave Band Filter type 1615 of Messrs. Brüel + Kjaer are used. These precision measuring instruments comply with DIN 45633. The sound power level L_W , referred to $W_0 = 10^{-12}$ watt, required for calculation and design of sound absorbing units is marked in the performance curves.

L_W	- Total Sound Power Level	[dB]
L_W^*	- Sound Power Level at a specific Octave Band Mid-Frequency	[dB]
L_P	- Sound Pressure Level (non-weighted)	[dB]
L_P^*	- Sound Pressure Level at a specific Octave Band Mid-Frequency	[dB]
L_{PA}	- Sound Pressure Level (weighted)	[dB(A)]
f_m	- Octave Band Mid-Frequency	[Hz]
Δ_L	- Difference between the Total Sound Power Level L_W and the non-weighted Sound Pressure Level L_P	[dB]
ΔL_W	- Difference between the Total Sound Power Level L_W and the measured value at the corresponding Octave Band Mid-Frequency	[dB]
ΔL_A	- Difference between the Total Sound Power Level L_W and the weighted Sound Pressure Level L_{PA}	[dB]

The Sound Data of the fans is determined as follows:

1. The Total Sound Power Level can be ascertained from the Performance Curves.
2. The Sound Power Level L_W^* at the different Octave Band Mid-Frequencies is determined from following equation:

$$L_W^* = L_W - \Delta L_W$$

The values for ΔL_W are given in Table 1.

Table 1:

Octave Band Mid-Frequency f_m Hz	63	125	250	500	1000	2000	4000	8000
ΔL_W [dB] for TLZ	6	7	10	12	13	15	19	23
ΔL_W [dB] for THLZ	4	6	7	9	11	15	19	23

3. The non weighted Sound Pressure Level L_P of for all fan sizes at various measuring distances is obtained from the following equation:

$$L_P = L_W - \Delta L$$

The values for ΔL are given in Table 2.

Table 2:

Distance form the fan	1 m	2 m	3 m	4 m	5 m
ΔL [dB]	6	12	15	18	20

4. The Sound Pressure level L_P^* at the different Octave Band Mid-Frequencies is obtained from the following equation:

$$L_P^* = L_P - \Delta L_W$$

The values for $\Delta L_W - \Delta L_A$ are given in Table 1.

5. The weighted Sound Pressure Level L_{PA} dB(A) is determined by the following equation:

$$L_{PA} = L_W - \Delta L_A$$

The values far ΔL_A are given in Table 3.

Table 3:

Fan size		160	180	200	225	250	280	315	355	400	450	500	560	630	710	800	900	1000
ΔL_A at a distance of	1 m	10	10	10	11	11	11	11	12	12	12	12	13	13	13	13	14	14
	2 m	16	16	16	17	17	17	17	18	18	18	18	19	19	19	19	20	20
	3 m	19	19	19	20	20	20	20	21	21	21	21	22	22	22	22	23	23
	4 m	22	22	22	23	23	23	23	24	24	24	24	25	25	25	25	26	26
	5 m	24	24	24	25	25	25	25	26	26	26	26	27	27	27	27	28	28

Please note that exact data regarding sound volume and frequency can only be determined after assembly and operation at the place of installation as the acoustic properties of the room, inherent frequencies as well as other oscillations and the effect of adjacent structures may considerably affect the sound level.

4.3 Performance Curves of the COMEFRI Fans

The fan data, which have been determined by tests in our laboratory, according to the latest recommendations and with high-precision measuring instruments, are contained in the following performance curves. They show the total pressure against the volume flow.

The curves indicate speed, circumferential velocity, power consumption at the shaft and Total Sound Power Level L_W .

Please note that the values indicated at the absciss, the dynamic pressure and the outlet velocity relate to the total cross section of the fan outlet.

4.3.1 Selection Example of double inlet Fans with high efficiency impeller with forward curved blades, type TLZ

Required:

Volume flow $V = 15000 \text{ m}^3/\text{h}$
 Total pressure $\Delta p_t = 1000 \text{ Pa}$
 Air density $\rho = 1,2 \text{ kg/m}^3$
 Air temperature $t = 293 \text{ K (20}^\circ\text{C)}$

To determinate:

Fan size
 Speed
 Power consumption
 Motor output
 Efficiency
 Sound pressure level
 in dB(A) at a distance of 3 m.

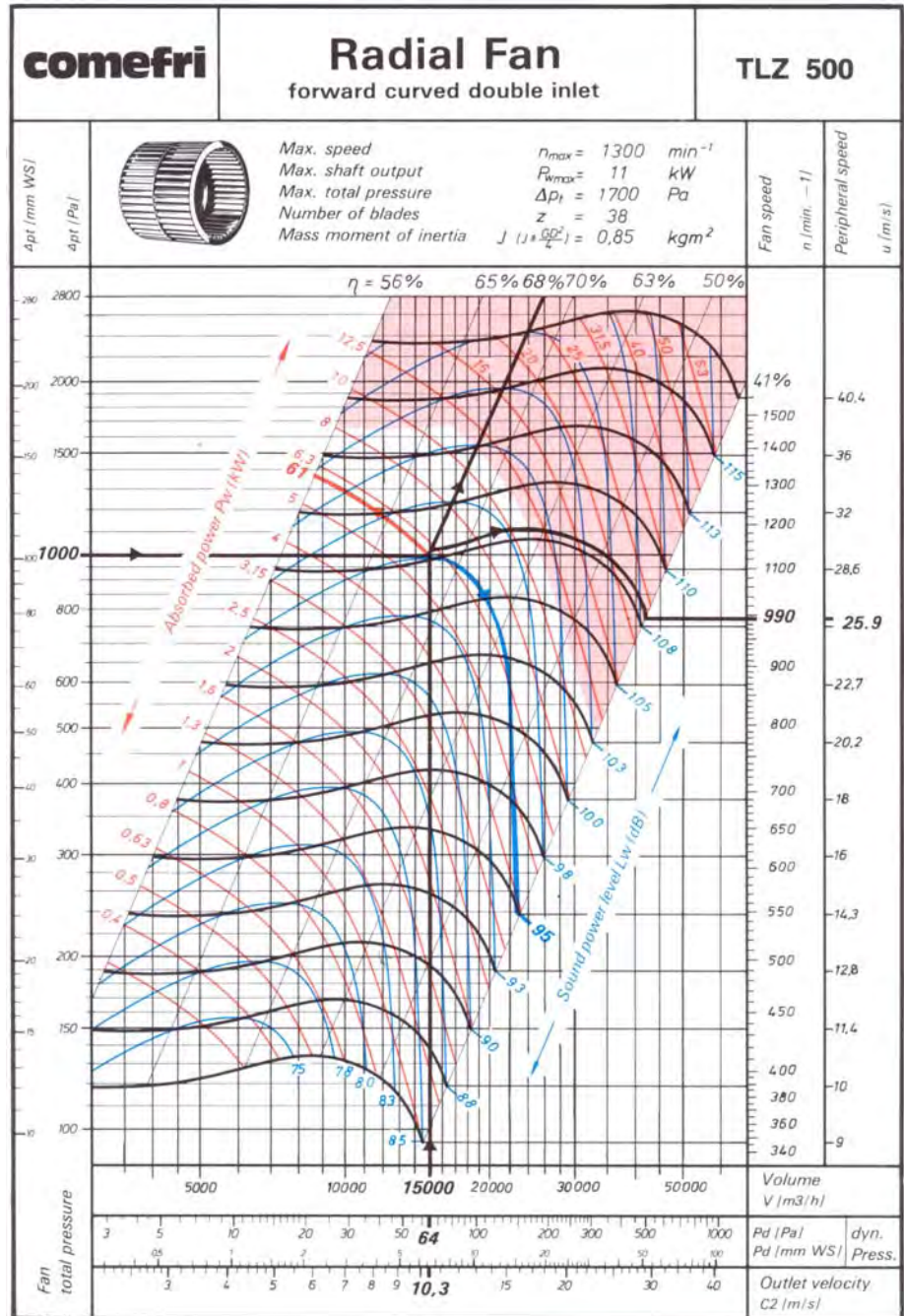

Selected from the Curve:

Radial Fan TLZ 500

Fan speed	n	=	990	min^{-1}
Circumferential speed	u	=	25.9	m/sec.
Dynamic pressure	p_d	=	64	Pa
Static pressure	p_{st}	=	936	Pa (Total – dynamic pressure)
Outlet velocity	c_2	=	10.3	m/sec.
Volume flow	V	=	15000	m^3/h
Efficiency	η	=	0.68	
Absorbed power	P_W	=	6.1	kW
Motor rating	P_M	=	$P_W + 20\%$	
Suond power level	L_W	=	95	dB
Sound pressure level	L_{PA}	=	$95 - 21 = 74$	dB(A)

4.3.2 Selection Example of double inlet Fans with high efficiency impeller with backw. curved blades, type THLZ

Required:

Volume flow $V = 15000 \text{ m}^3/\text{h}$
 Total pressure $\Delta p_t = 1000 \text{ Pa}$
 Air density $\rho = 1,2 \text{ kg/m}^3$
 Air temperature $t = 293 \text{ K (20}^\circ\text{C)}$

To determinate:

Fan size
 Speed
 Power consumption
 Motor output
 Efficiency
 Sound pressure level
 in dB(A) at a distance of 3 m.

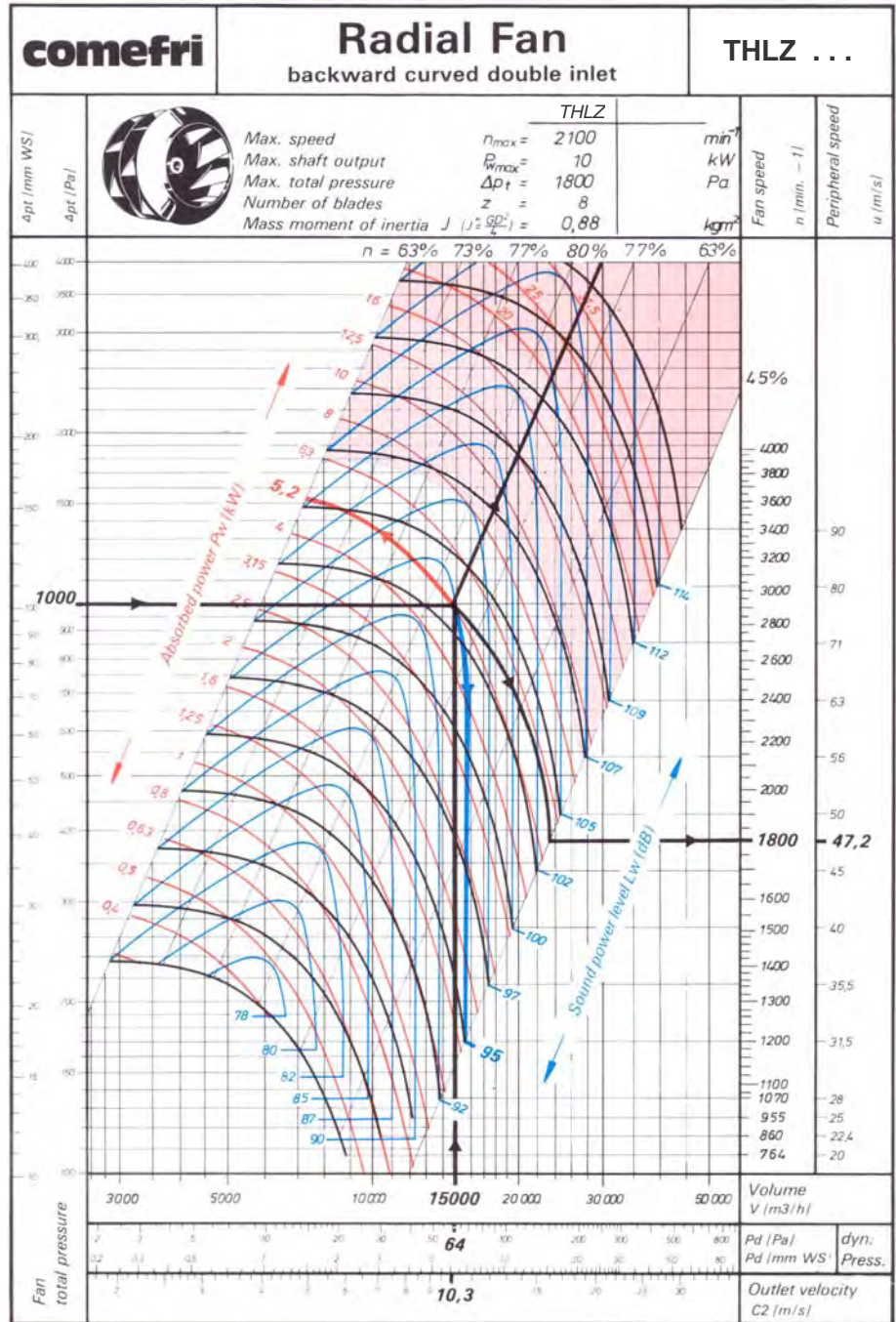

Selected from the Curve:

Radial Fan THLZ . . .

Fan speed	n	= 1800	min^{-1}
Circumferential speed	u	= 47.2	m/sec.
Dynamic pressure	p_d	= 64	Pa
Static pressure	p_{st}	= 936	Pa (Total – dynamic pressure)
Outlet velocity	c_2	= 10.3	m/sec.
Volume flow	V	= 15000	m^3/h
Efficiency	η	= 0.80	
Absorbed power	P_W	= 5.2	kW
Motor rating	P_M	= $P_W + 15\%$	
Suond power level	L_W	= 95	dB
Sound pressure level	L_{PA}	= $95 - 21 =$	74 dB(A)



Max. speed $n_{max} = 7000 \text{ min}^{-1}$
 Max. shaft power $P_{Wmax} = 3,0 \text{ kW}$
 Max. total pressure $\Delta p_t = 2100 \text{ Pa.}$
 Number of blades $z = 8$
 Mass moment of inertia $J. (J = \frac{GD^2}{4}) = 0,005 \text{ kg m}^2$

Fan speed $n \text{ (min}^{-1}\text{)}$
 Peripheral speed $u \text{ (m/s)}$

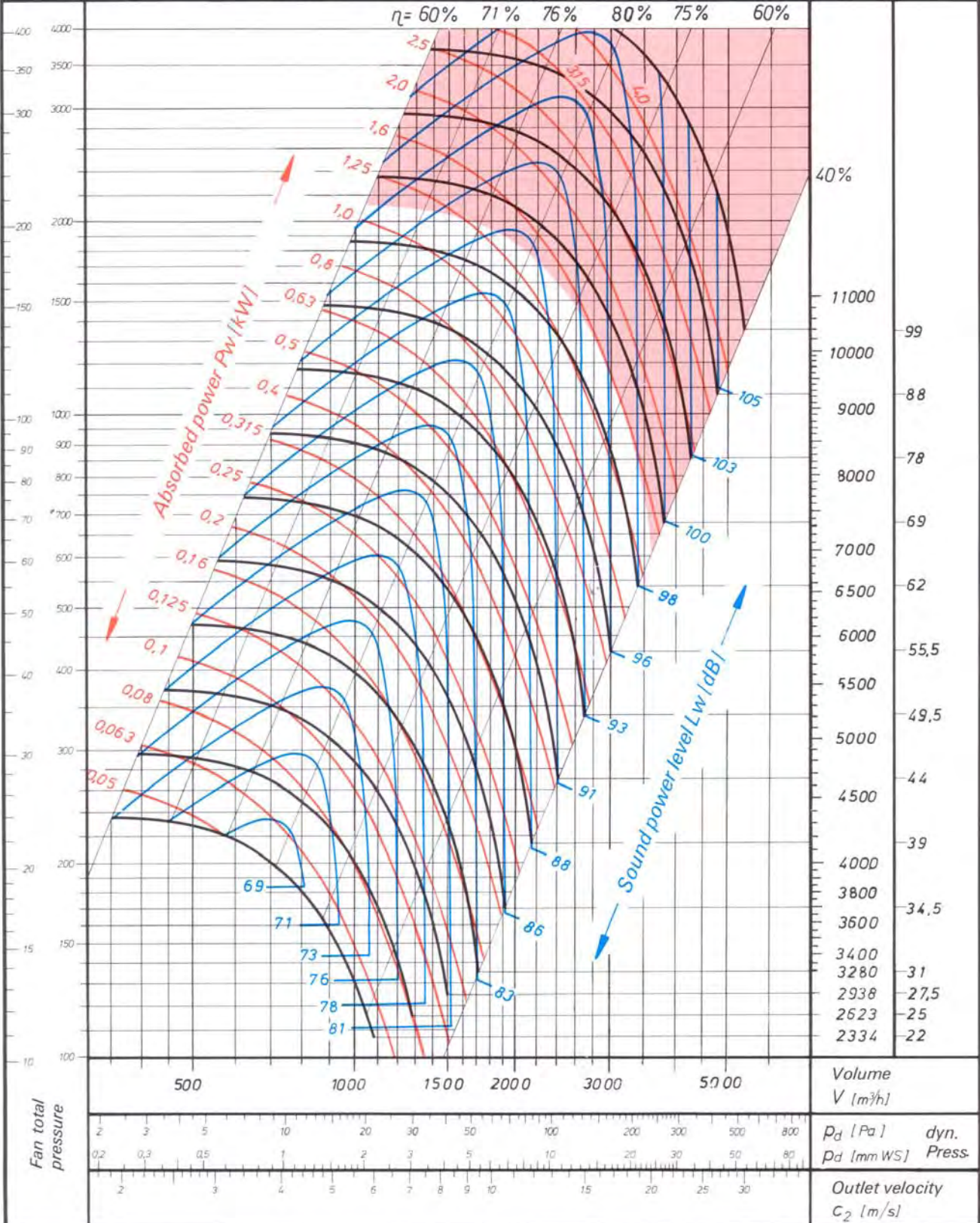

comefri

Radial Fan

backward curved double inlet

THLZ 200



Max. speed $n_{max} = 6200 \text{ min}^{-1}$
 Max. shaft power $P_{Wmax} = 3,5 \text{ kW}$
 Max. total pressure $\Delta p_t = 2100 \text{ Pa}$
 Number of blades $z = 8$
 Mass moment of inertia $J (J = \frac{GD^2}{4}) = 0,010 \text{ kgm}^2$

Fan speed $n \text{ (min}^{-1}\text{)}$
 Peripheral speed $u \text{ (m/s)}$

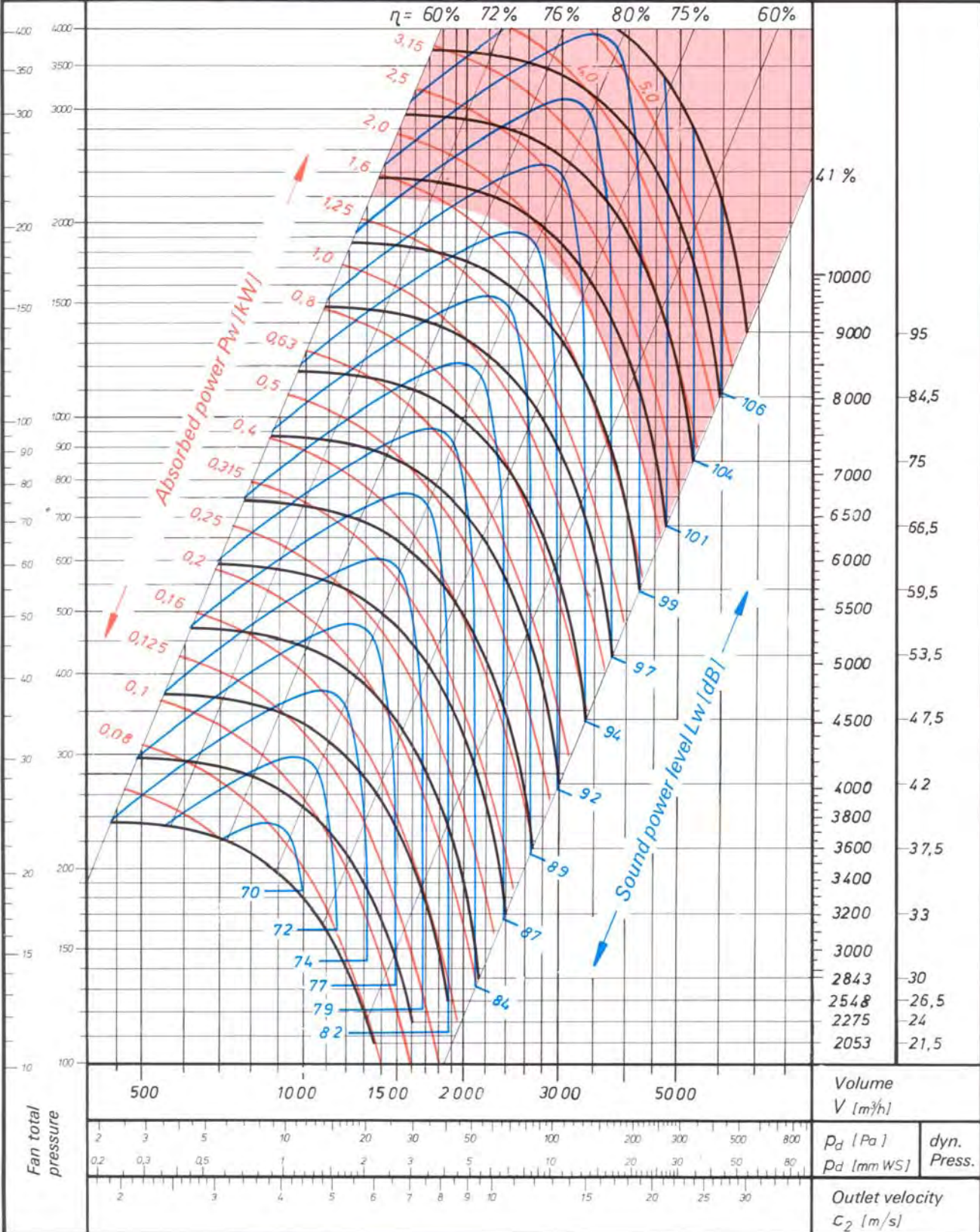



Max. speed $n_{max} = 6200 \text{ min}^{-1}$
 Max. shaft power $P_{wmax} = 4,0 \text{ kW}$
 Max. total pressure $\Delta p_t = 2900 \text{ Pa}$
 Number of blades $z = 8$
 Mass moment of inertia $J (J \hat{=} \frac{GD^2}{4}) = 0,014 \text{ kg m}^2$

Fan speed

$n \text{ (min}^{-1}\text{)}$

Peripheral speed

$u \text{ (m/s)}$

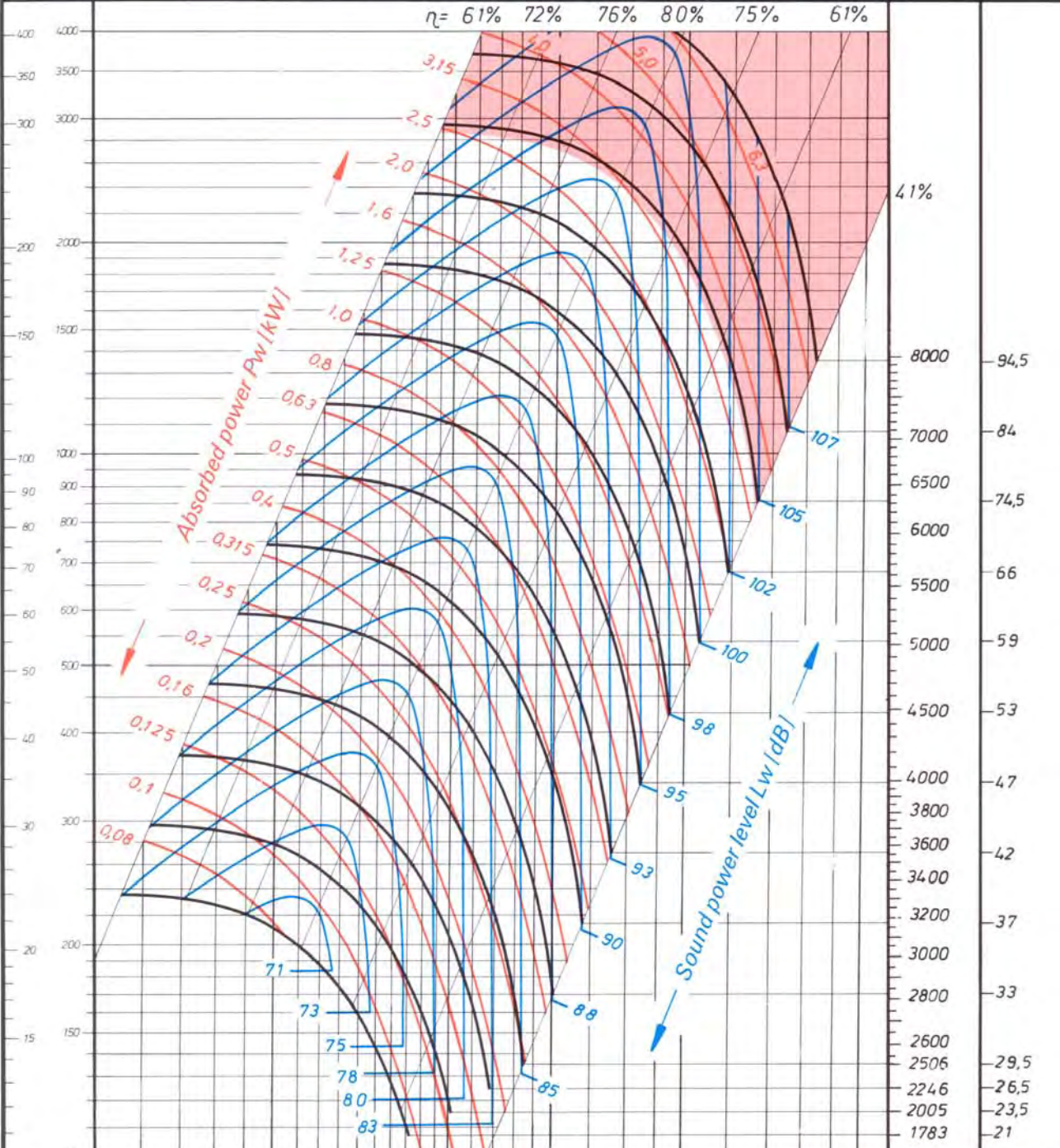

Fan total pressure	Volume V [m^3/h]	P_d [Pa]	dyn. Press.
		P_d [mm WS]	
	Outlet velocity c_2 [m/s]		

comefri

Radial Fan

backward curved double inlet

THLZ 250



Max. speed $n_{max} = 5800 \text{ min}^{-1}$
 Max. shaft power $P_{wmax} = 5,0 \text{ kW}$
 Max. total pressure $\Delta p_t = 3400 \text{ Pa}$
 Number of blades $z = 8$
 Mass moment of inertia $J (J = \frac{GD^2}{4}) = 0,02 \text{ kgm}^2$

Fan speed $n \text{ (min}^{-1}\text{)}$
 Peripheral speed $u \text{ (m/s)}$

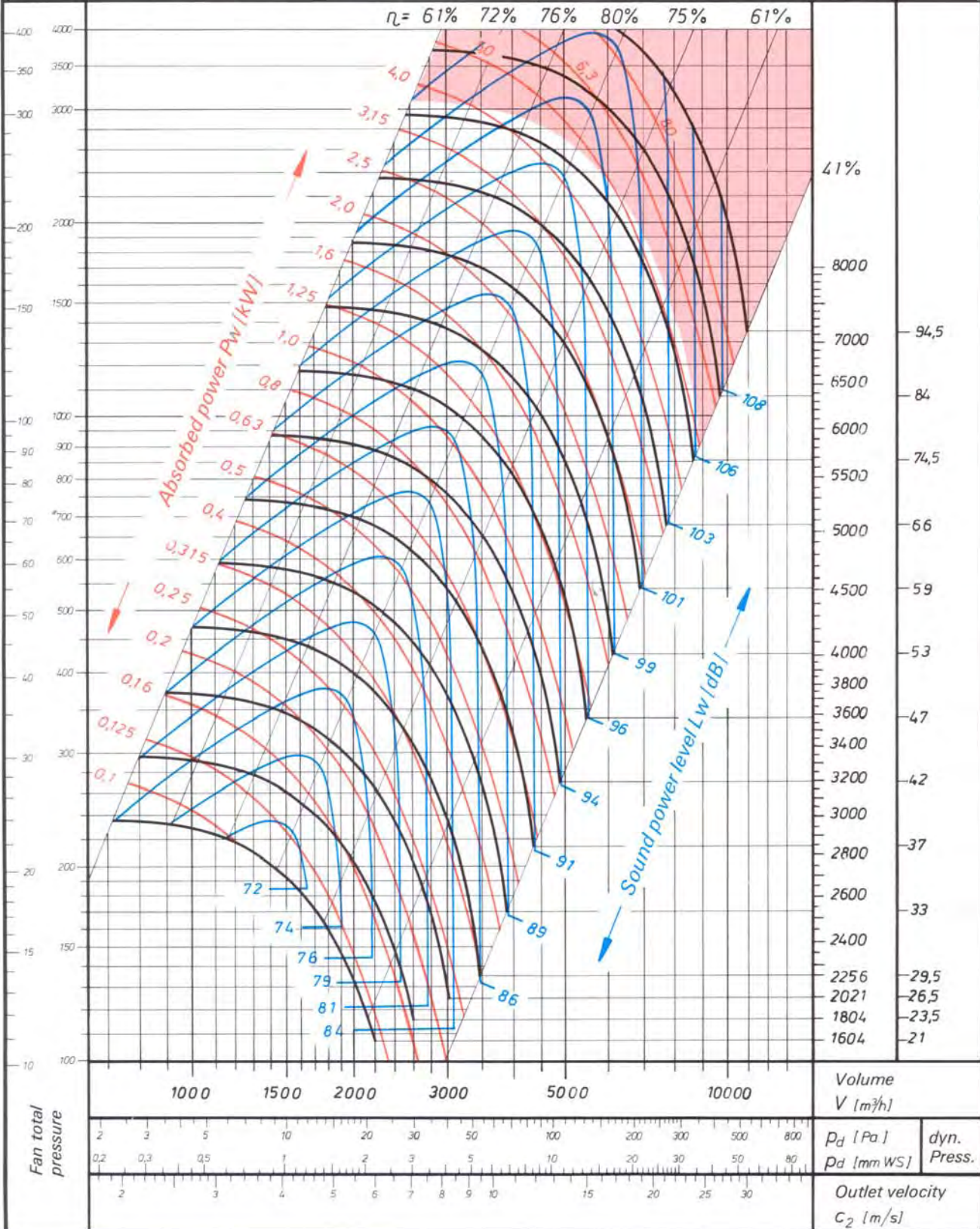

comefri

Radial Fan

backward curved double inlet

THLZ 280



Max. speed $n_{max} = 4700 \text{ min}^{-1}$
 Max. shaft power $P_{wmax} = 5,2 \text{ kW}$
 Max. total pressure $\Delta p_t = 2800 \text{ Pa}$
 Number of blades $z = 8$
 Mass moment of inertia $J (J = \frac{GD^2}{4}) = 0,034 \text{ kg m}^2$

Fan speed $n \text{ (min}^{-1}\text{)}$
 Peripheral speed $u \text{ (m/s)}$

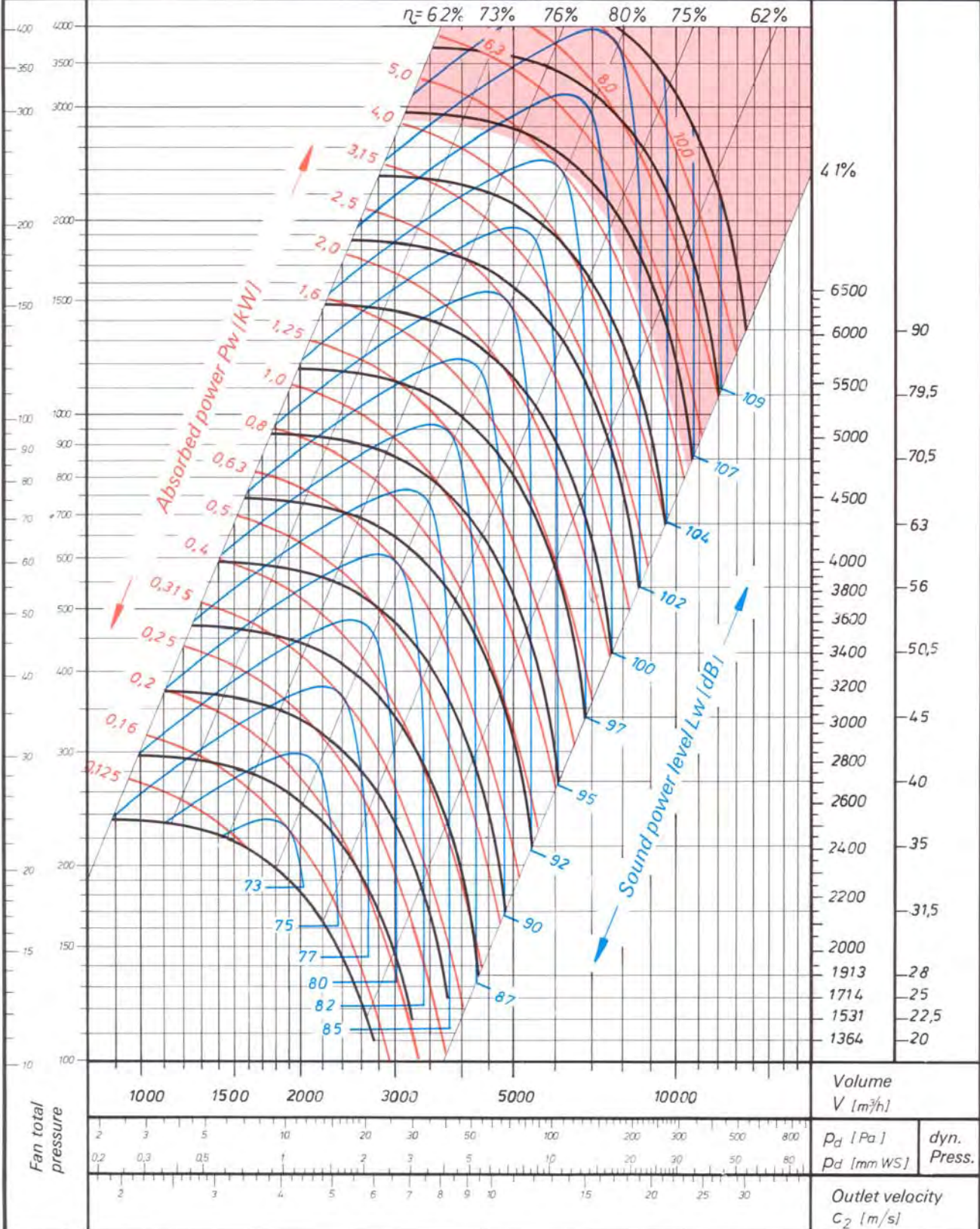



Max. speed $n_{max} = 3700 \text{ min}^{-1}$
 Max. shaft power $P_{wmax} = 5,6 \text{ kW}$
 Max. total pressure $\Delta p_t = 2200 \text{ Pa}$
 Number of blades $z = 8$
 Mass moment of inertia $J (J = \frac{GD^2}{4}) = 0,05 \text{ kgm}^2$

Fan speed $n \text{ (min}^{-1}\text{)}$
 Peripheral speed $u \text{ (m/s)}$

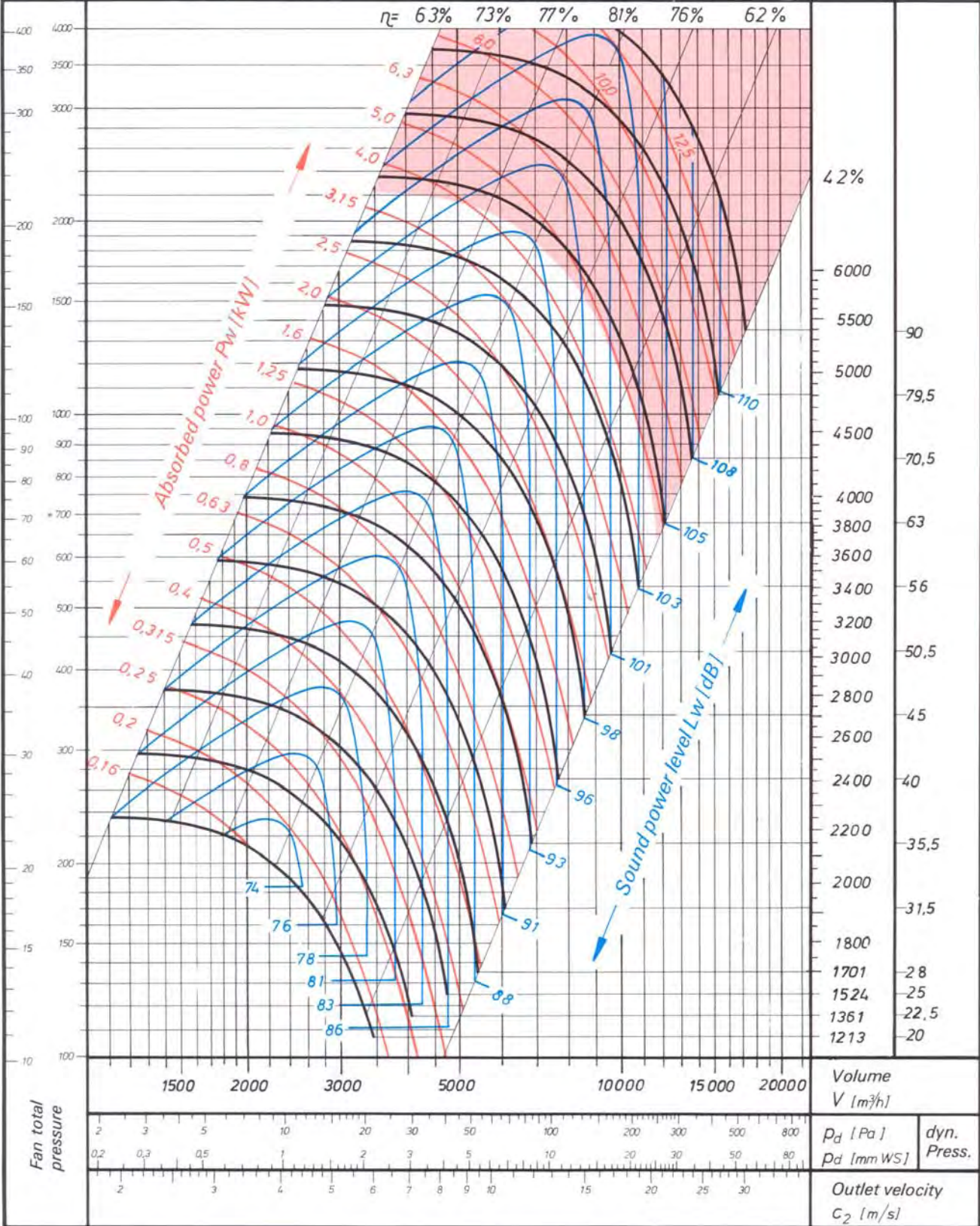



Max. speed $n_{max} = 3400 \text{ min}^{-1}$
 Max. shaft power $P_{wmax} = 7,0 \text{ kW}$
 Max. total pressure $\Delta p_t = 2400 \text{ Pa}$
 Number of blades $z = 8$
 Mass moment of inertia $J (J = \frac{GD^2}{4}) = 0,1 \text{ kgm}^2$

Fan speed $n \text{ (min}^{-1}\text{)}$
 Peripheral speed $U \text{ (m/s)}$

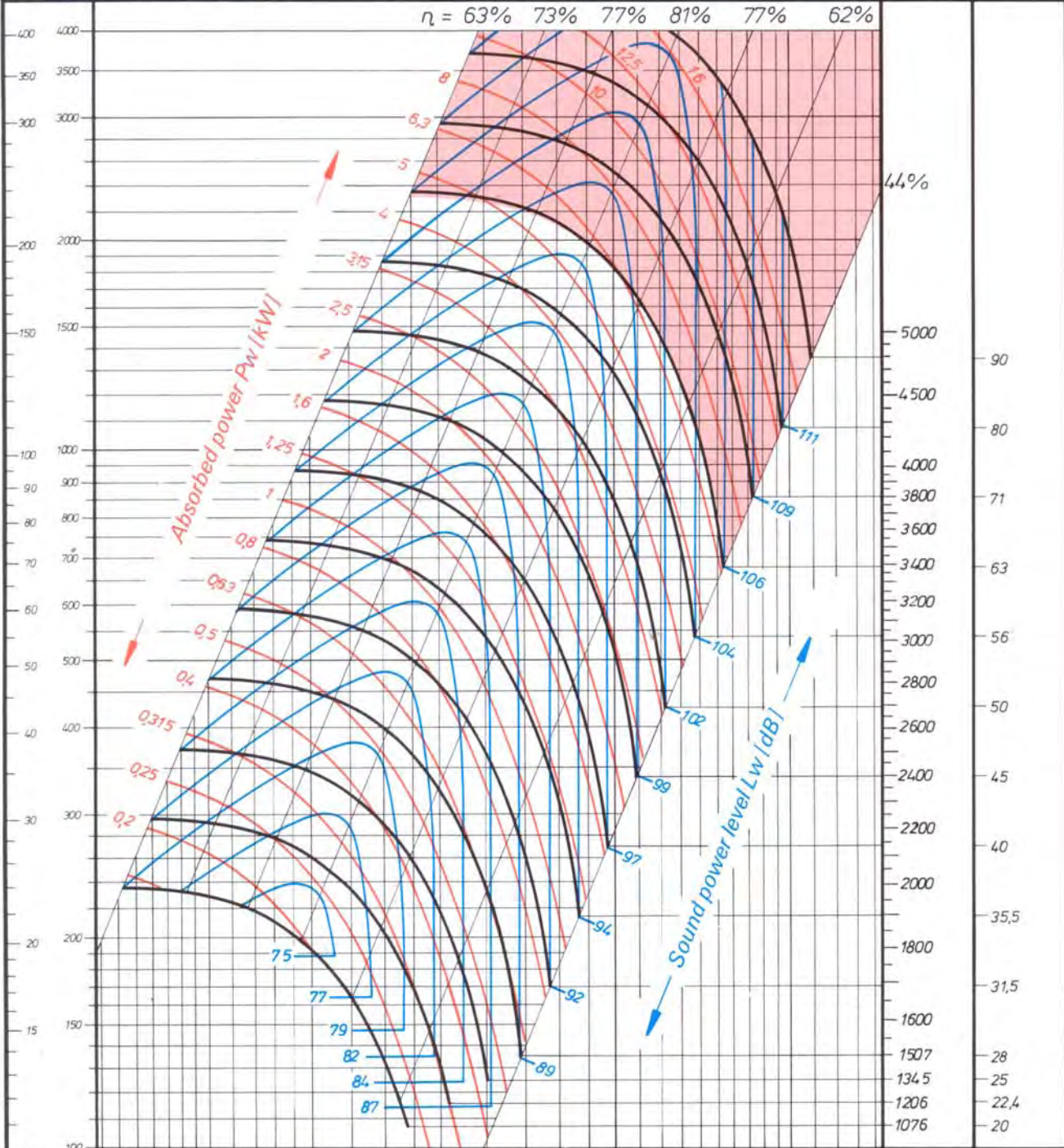

Fan total pressure	Volume $V \text{ (m}^3\text{/h)}$	$\rho_d \text{ [Pa]}$	dyn. Press.
1500 2000 3000 5000 10000 15000 20000	2 3 5 10 20 30 50 100 200 300 500 800	$\rho_d \text{ [mm WS]}$	
10 15 20 30 40 50 60 70 80 90 99 102 104 106 109 111	2 3 4 5 6 7 8 9 10 15 20 25 30	Outlet velocity $C_2 \text{ (m/s)}$	

comefri

Radial Fan

backward curved double inlet

THLZ 400



Max. speed $n_{max} = 2850 \text{ min}^{-1}$
 Max. shaft power $P_{Wmax} = 7,5 \text{ kW}$
 Max. total pressure $\Delta p_{t1} = 2100 \text{ Pa}$
 Number of blades $z = 8$
 Mass moment of inertia $J (U = \frac{60n}{s}) = 0,15 \text{ kgm}^2$

Fan speed
 $n \text{ [min}^{-1}\text{]}$

Peripheral speed
 $U \text{ [m/s]}$

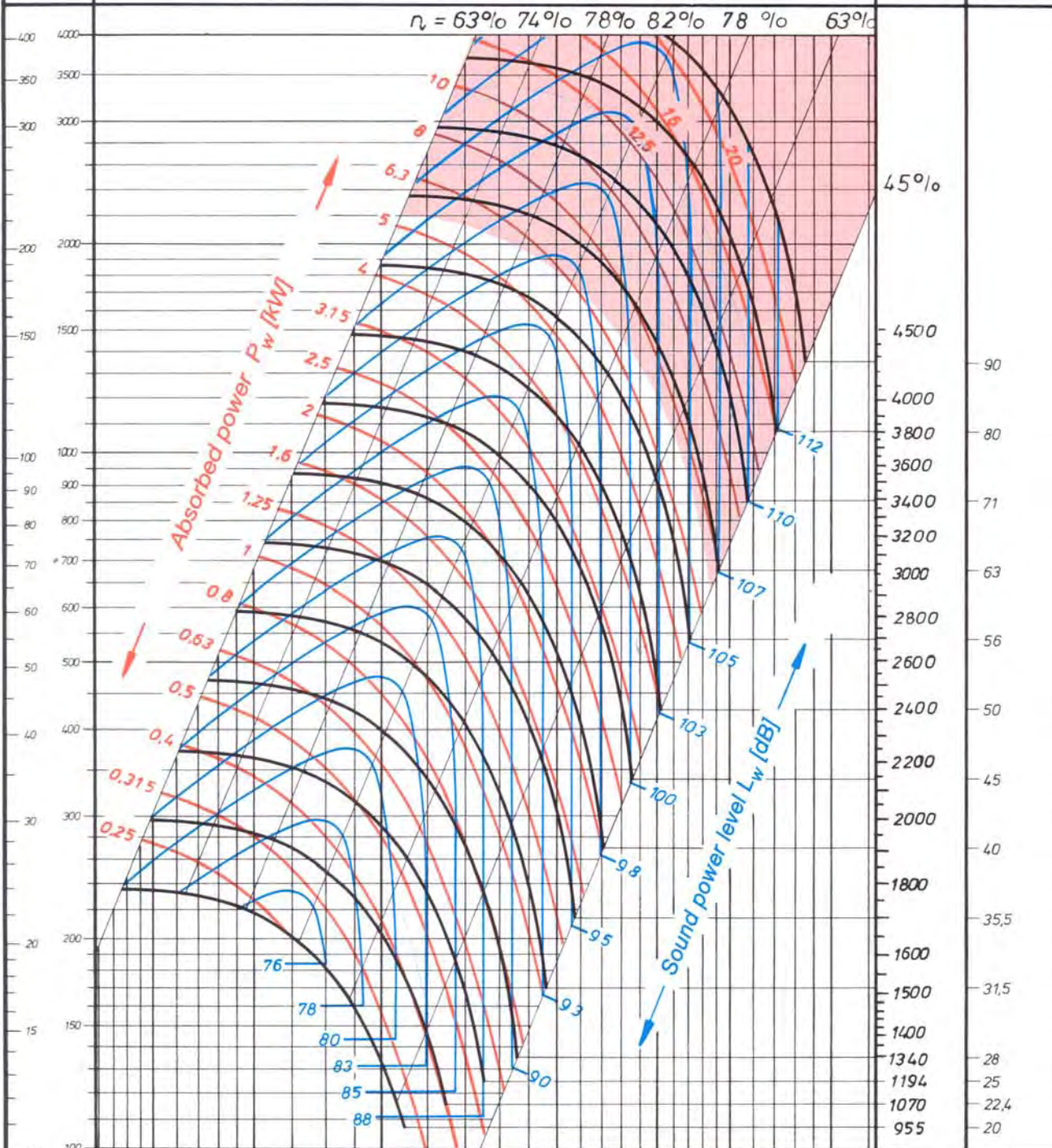

Volume $V \text{ [m}^3\text{/h]}$

$P_d \text{ [Pa]}$ dyn. Press.
 $P_d \text{ [mm WS]}$

Outlet velocity $C_2 \text{ [m/s]}$

comefri

Radial Fan

backward curved double inlet

THLZ 450



Max. speed $n_{max} = 2500 \text{ min}^{-1}$
 Max. shaft power $P_{Wmax} = 8 \text{ kW}$
 Max. total pressure $\Delta p_t = 2000 \text{ Pa}$
 Number of blades $z = 8$
 Mass moment of inertia $J (d^2 = 90^2) = 0,33 \text{ kgm}^2$

Fan speed $n \text{ [min}^{-1}\text{]}$
 Peripheral speed $u \text{ [m/s]}$

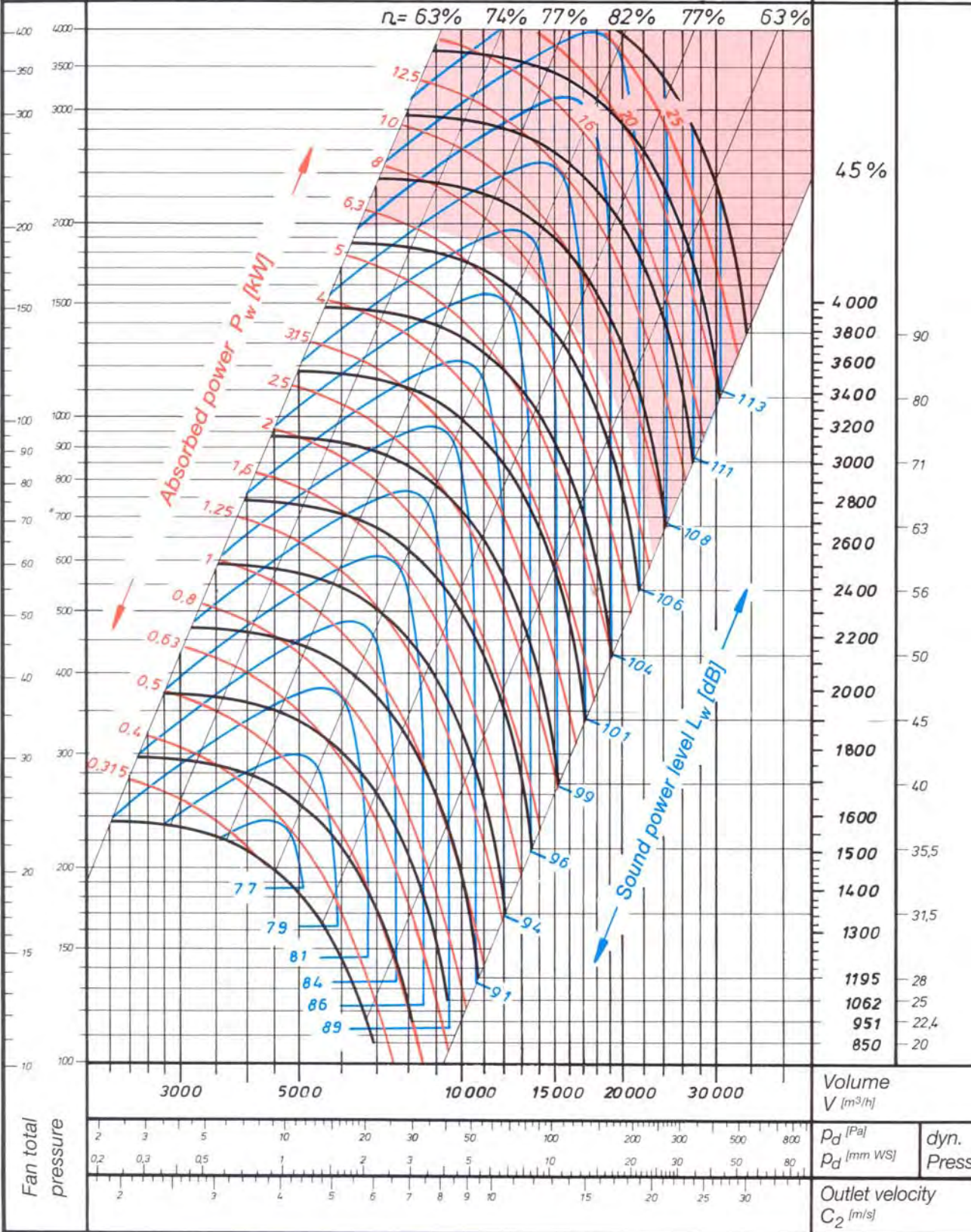

comefri

Radial Fan

forward curved double inlet

TLZ 160



Max. speed
Max. shaft power
Max. total pressure
Number of blades
Mass moment of inertia

$n_{max} = 4250 \text{ min}^{-1}$
 $P_{wmax} = 3,5 \text{ kW}$
 $\Delta p_t = 1800 \text{ Pa}$
 $z = 36$
 $J (J = \frac{GD^2}{4}) = 0,01 \text{ kgm}^2$

Fan speed
 $n \text{ (min}^{-1}\text{)}$
Peripheral speed
 $u \text{ (m/s)}$

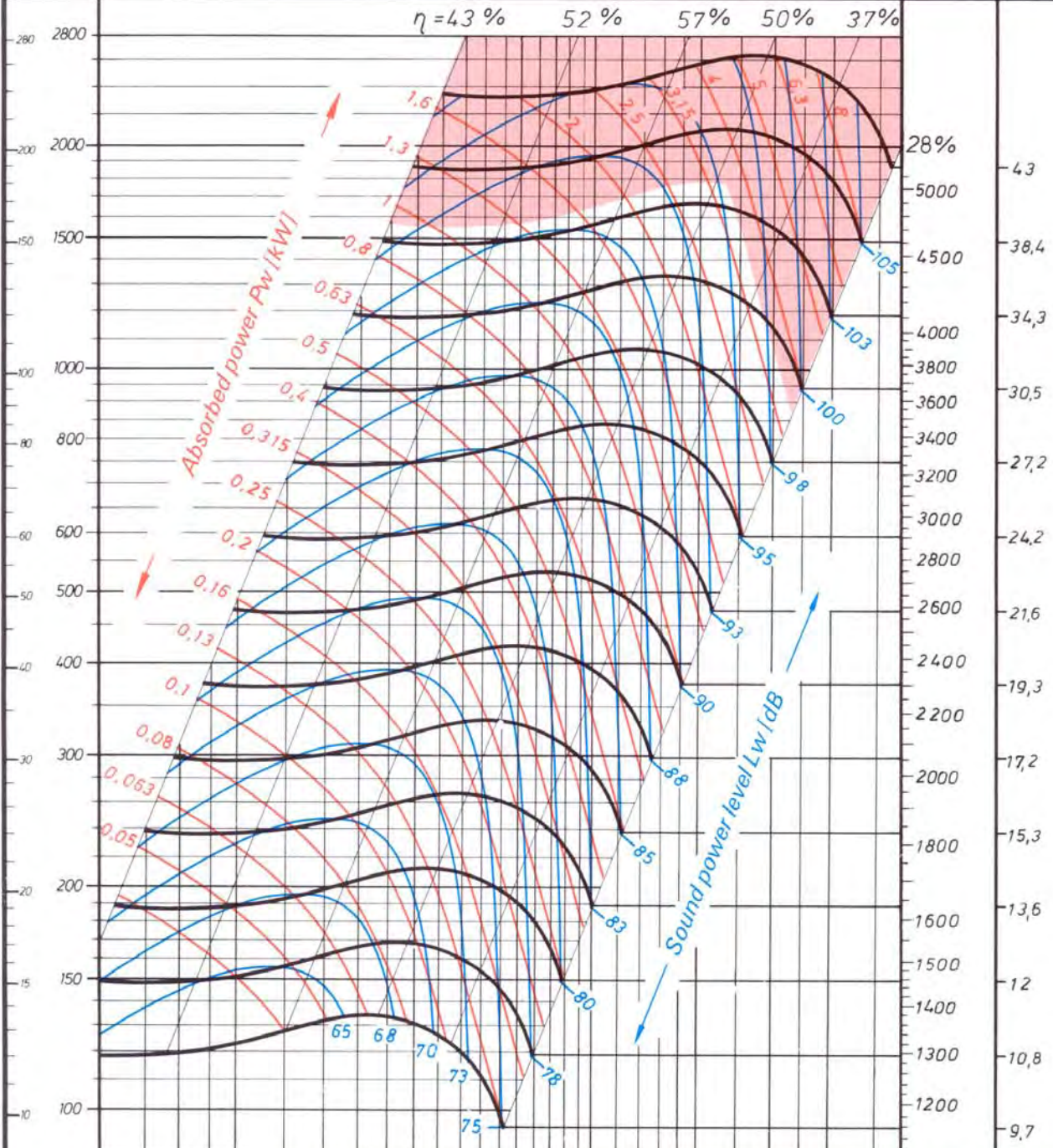

Fan total pressure	Volume $V \text{ (m}^3\text{/h)}$	$p_d \text{ (Pa)}$	dyn. Press.
		$p_d \text{ (mm WS)}$	
	Outlet velocity $C_2 \text{ (m/s)}$		



Max. speed $n_{max} = 4000 \text{ min}^{-1}$
 Max. shaft power $P_{Wmax} = 3,5 \text{ kW}$
 Max. total pressure $\Delta p_t = 2000 \text{ Pa}$
 Number of blades $z = 40$
 Mass moment of inertia $J (J = \frac{GD^2}{4}) = 0,013 \text{ kgm}^2$

Fan speed $n \text{ (min}^{-1}\text{)}$
 Peripheral speed $u \text{ (m/s)}$

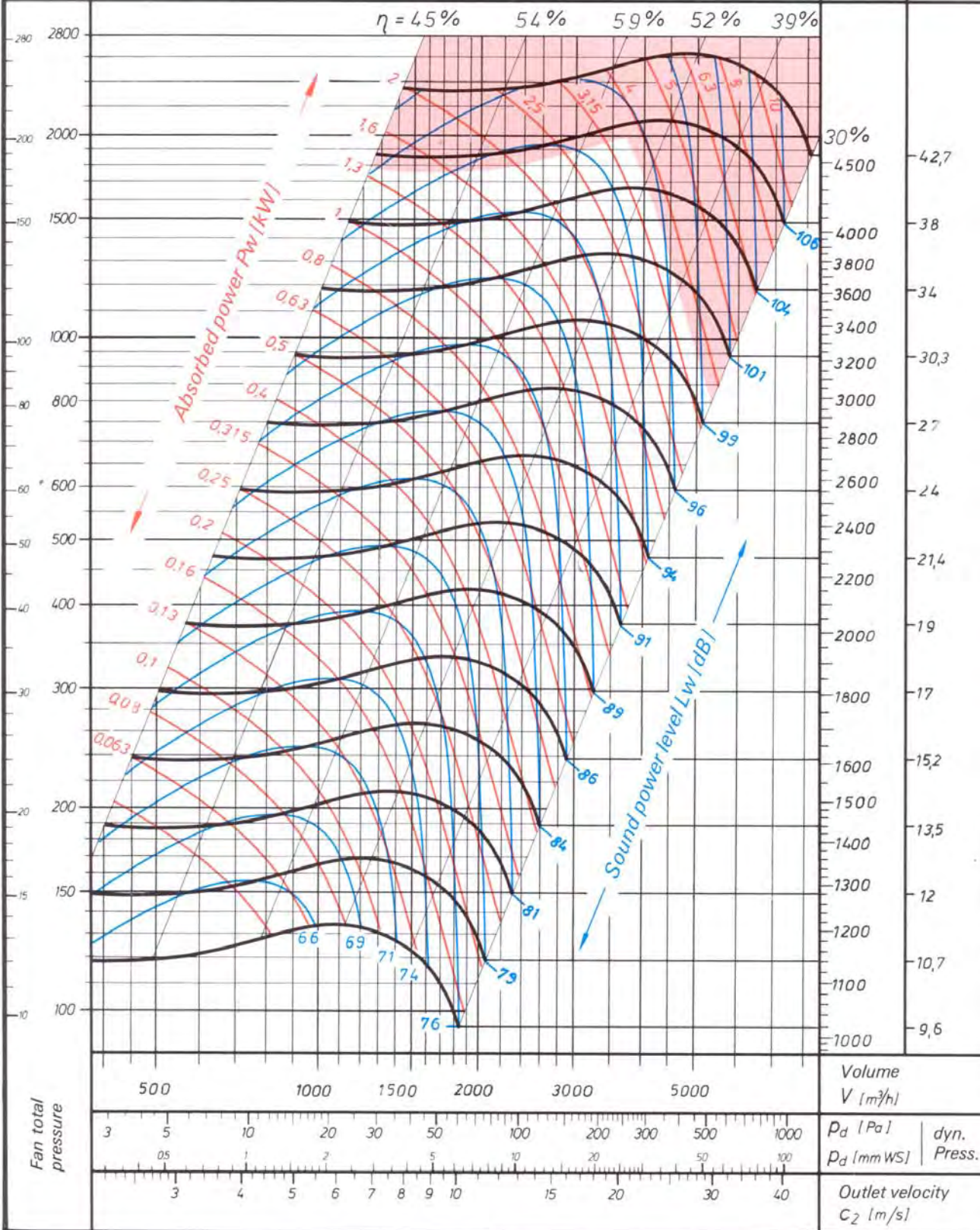



Max. speed
Max. shaft power
Max. total pressure
Number of blades
Mass moment of inertia

$n_{max} = 3800 \text{ min}^{-1}$
 $P_{wmax} = 4,0 \text{ kW}$
 $\Delta p_t = 2100 \text{ Pa}$
 $z = 38$
 $J (J = \frac{GD^2}{4}) = 0,018 \text{ kgm}^2$

Fan speed
 $n \text{ (min}^{-1}\text{)}$

Peripheral speed
 $U \text{ (m/s)}$

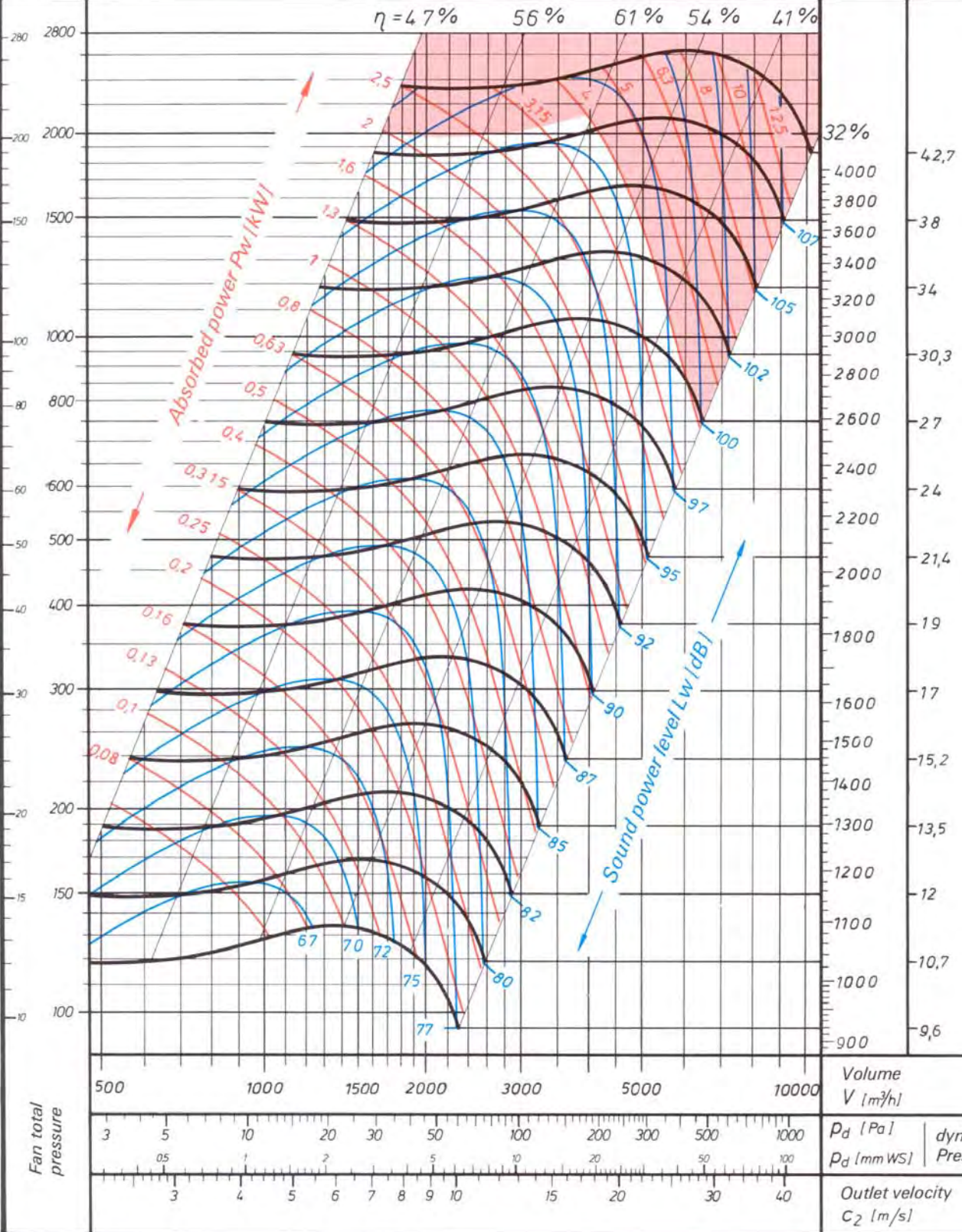

comefri

Radial Fan

forward curved double inlet

TLZ 225



Max. speed
Max. shaft power
Max. total pressure
Number of blades
Mass moment of inertia

$n_{max} = 3400 \text{ min}^{-1}$
 $P_{wmax} = 5,0 \text{ kW}$
 $\Delta p_t = 2200 \text{ Pa}$
 $z = 42$
 $J (J = \frac{GD^2}{4}) = 0,028 \text{ kgm}^2$

Fan speed
 $n \text{ (min}^{-1}\text{)}$

Peripheral speed
 $u \text{ (m/s)}$

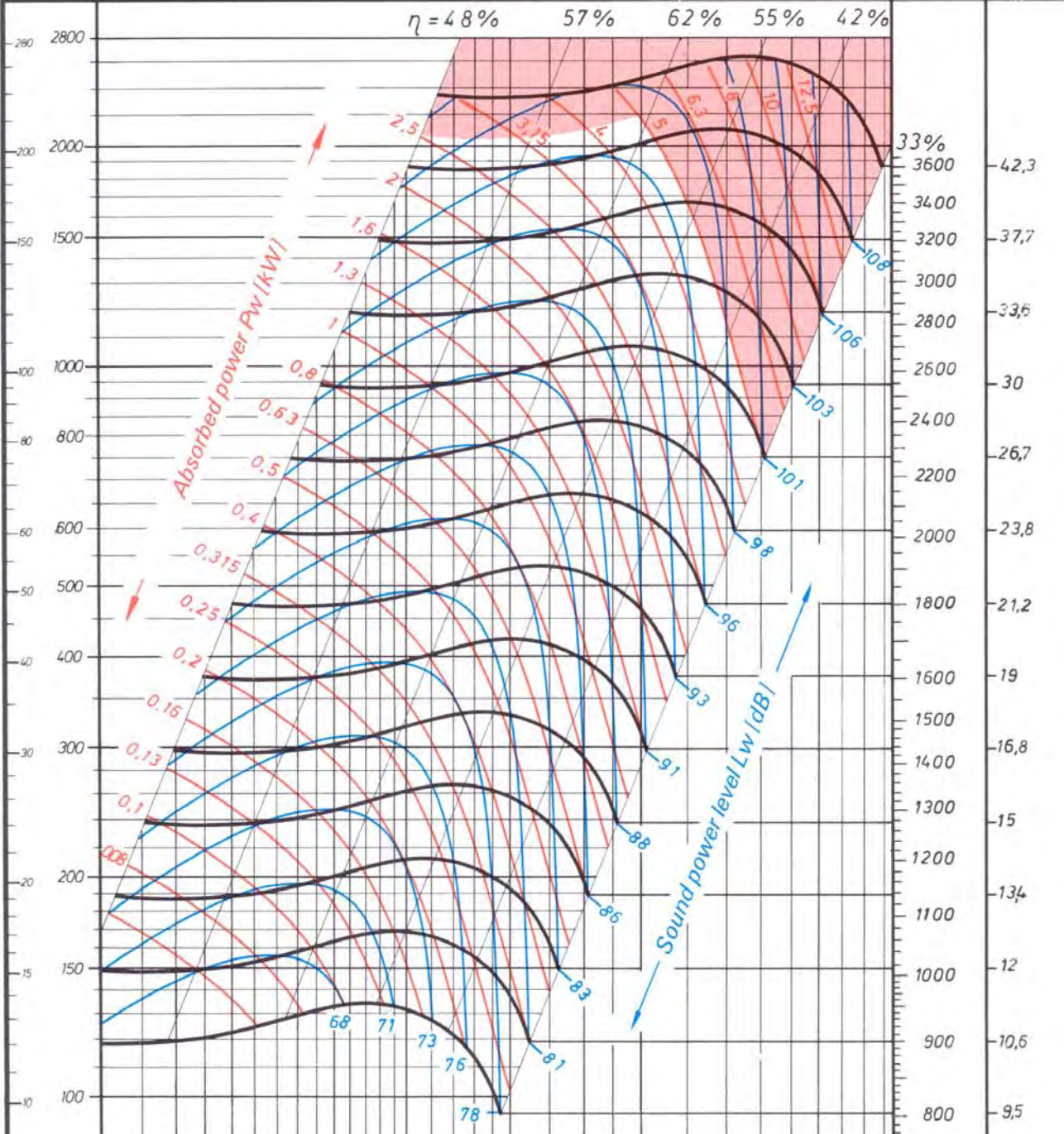

comefri

Radial Fan forward curved double inlet

TLZ 250



Max. speed
Max. shaft power
Max. total pressure
Number of blades
Mass moment of inertia

$n_{max} = 3000 \text{ min}^{-1}$
 $P_{wmax} = 5,0 \text{ kW}$
 $\Delta p_t = 2100 \text{ Pa}$
 $z = 38$
 $J (J = \frac{GD^2}{4}) = 0,044 \text{ kgm}^2$

Fan speed
 $n \text{ (min}^{-1}\text{)}$

Peripheral speed
 $U \text{ (m/s)}$

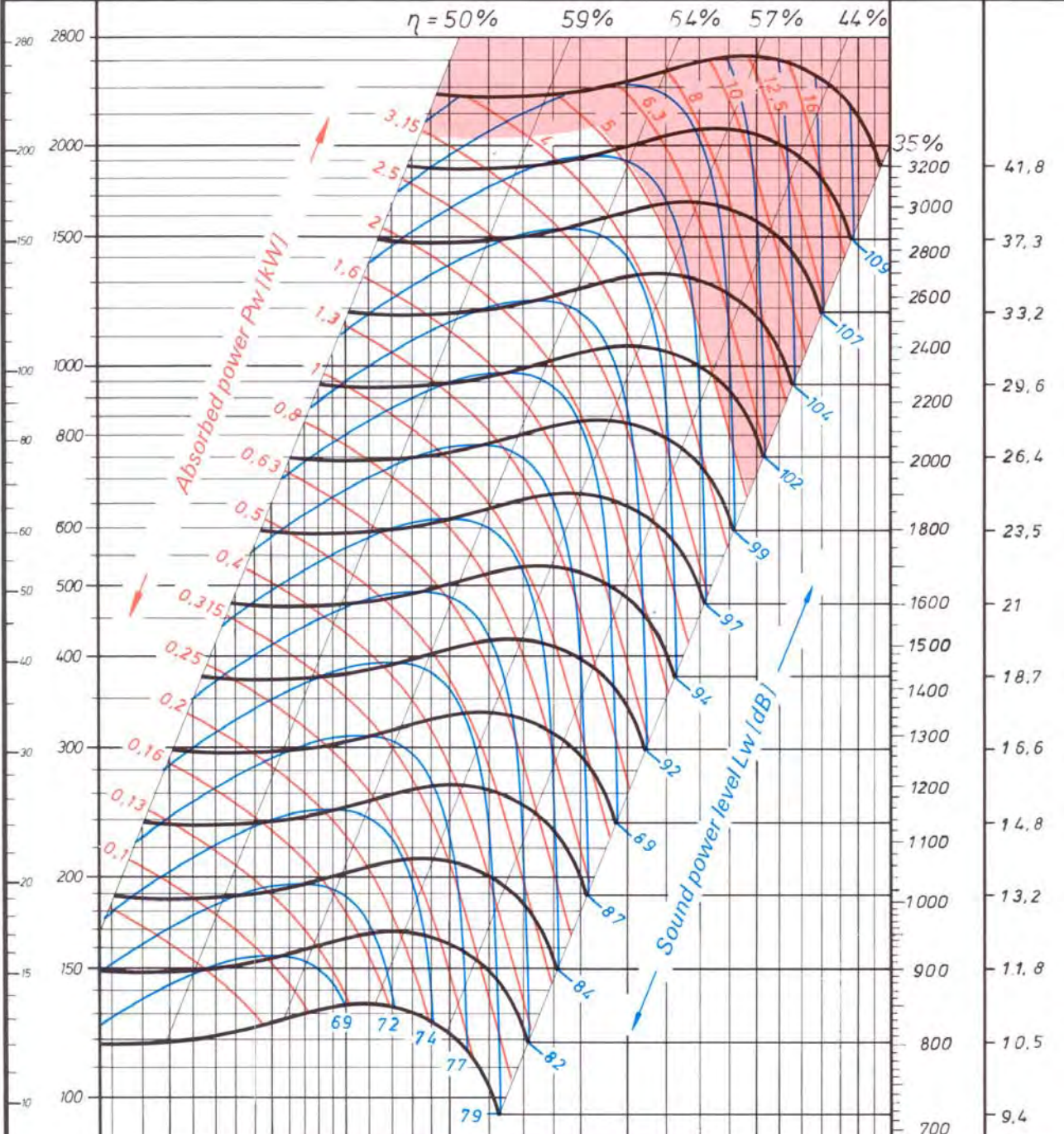

Fan total pressure	3 5 10 20 30 50 100 200 300 500 1000	$P_d \text{ (Pa)}$	dyn. Press.
	0.5 1 2 5 10 20 50 100	$P_d \text{ (mm WS)}$	
	3 4 5 6 7 8 9 10 15 20 30 40	Outlet velocity $C_2 \text{ (m/s)}$	

comefri

Radial Fan

forward curved double inlet

TLZ 280



Max. speed
Max. shaft power
Max. total pressure
Number of blades
Mass moment of inertia

$n_{max} = 2730 \text{ min}^{-1}$
 $P_{wmax} = 6,3 \text{ kW}$
 $\Delta p_t = 2200 \text{ Pa}$
 $z = 42$
 $J (J = \frac{GD^2}{4}) = 0,06 \text{ kgm}^2$

Fan speed
 $n \text{ (min}^{-1}\text{)}$

Peripheral speed
 $U \text{ (m/s)}$

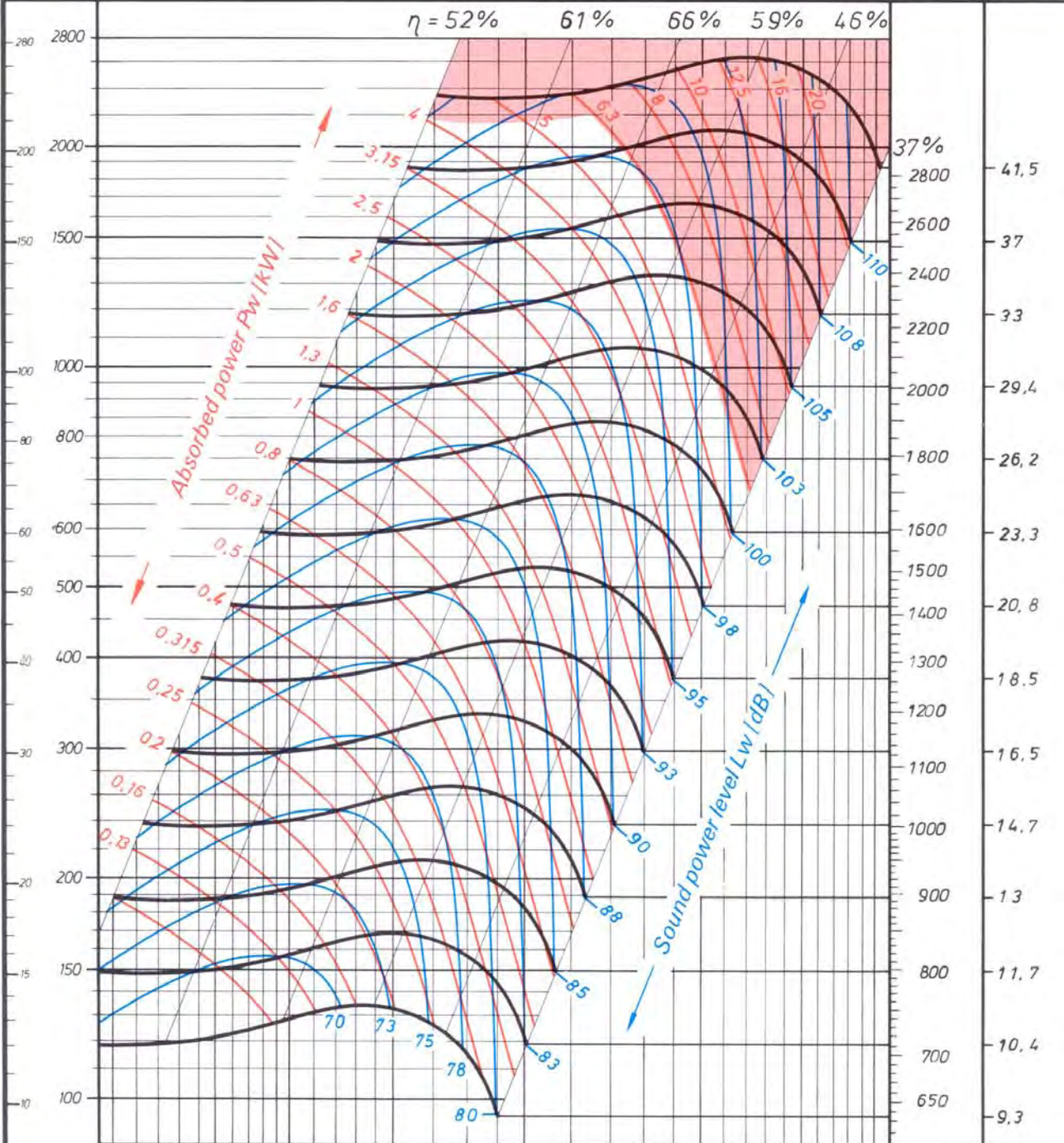

Fan total pressure	1000 1500 2000 3000 5000 10000 15000 20000	Volume $V \text{ (m}^3\text{/h)}$
	3 5 10 20 30 50 100 200 300 500 1000	$P_d \text{ (Pa)}$ dyn. Press.
	0.5 1 2 5 10 20 50 100	$P_d \text{ (mm WS)}$
	3 4 5 6 7 8 9 10 15 20 30 40	Outlet velocity $C_2 \text{ (m/s)}$

comefri

Radial Fan

forward curved double inlet

TLZ 315



Max. speed
Max. shaft power
Max. total pressure
Number of blades
Mass moment of inertia

$n_{max} = 2400 \text{ min}^{-1}$
 $P_{wmax} = 7,0 \text{ kW}$
 $\Delta p_t = 2200 \text{ Pa}$
 $z = 38$
 $J (J = \frac{GD^2}{4}) = 0,104 \text{ kgm}^2$

Fan speed
 $n \text{ (min}^{-1}\text{)}$

Peripheral speed
 $U \text{ (m/s)}$

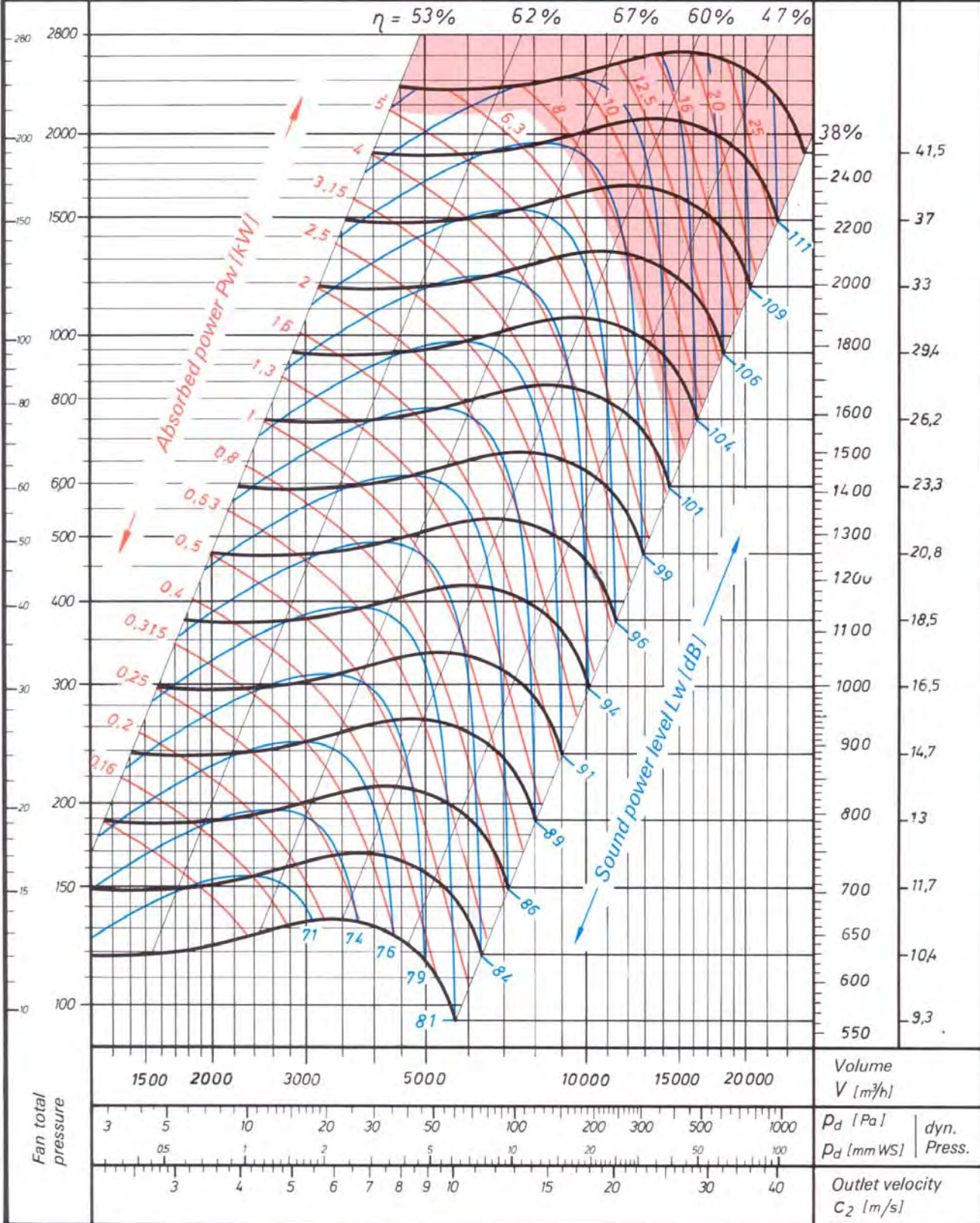

comefri

Radial Fan

forward curved double inlet

TLZ 355



Max. speed
Max. shaft power
Max. total pressure
Number of blades
Mass moment of inertia

$n_{max} = 1900 \text{ min}^{-1}$
 $P_{wmax} = 9,0 \text{ kW}$
 $\Delta p_t = 1800 \text{ Pa}$
 $z = 42$
 $J (J = \frac{GD^2}{4}) = 0,15 \text{ kgm}^2$

Fan speed
 $n \text{ (min}^{-1}\text{)}$
Peripheral speed
 $u \text{ (m/s)}$

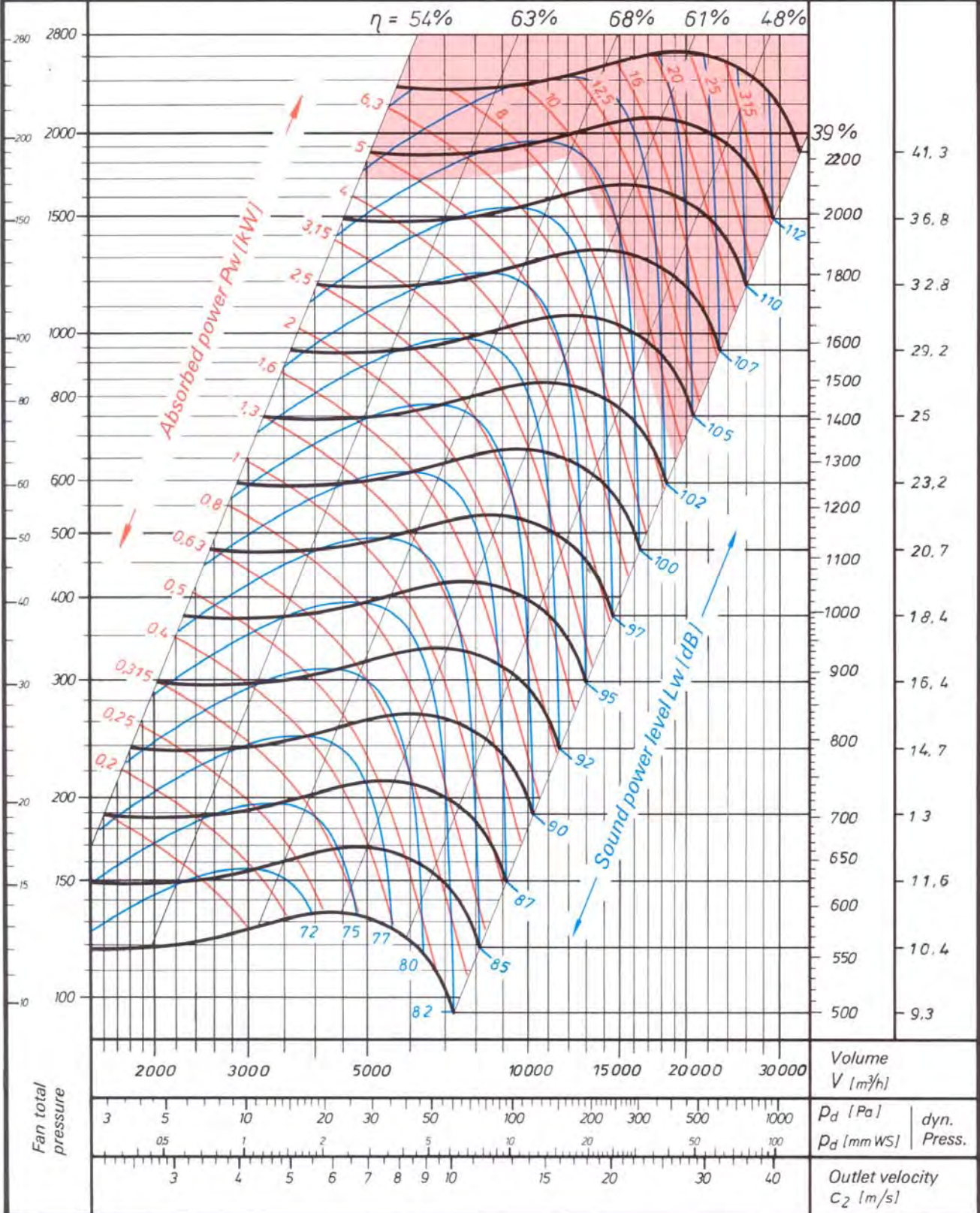

comefri

Radial Fan forward curved double inlet

TLZ 400



Max. speed
Max. shaft power
Max. total pressure
Number of blades
Mass moment of inertia

$n_{max} = 1700 \text{ min}^{-1}$
 $P_{wmax} = 9,0 \text{ kW}$
 $\Delta p_t = 1800 \text{ Pa}$
 $z = 38$
 $J (J = \frac{GD^2}{4}) = 0,3 \text{ kgm}^2$

Fan speed
 $n \text{ (min}^{-1}\text{)}$
Peripheral speed
 $U \text{ (m/s)}$

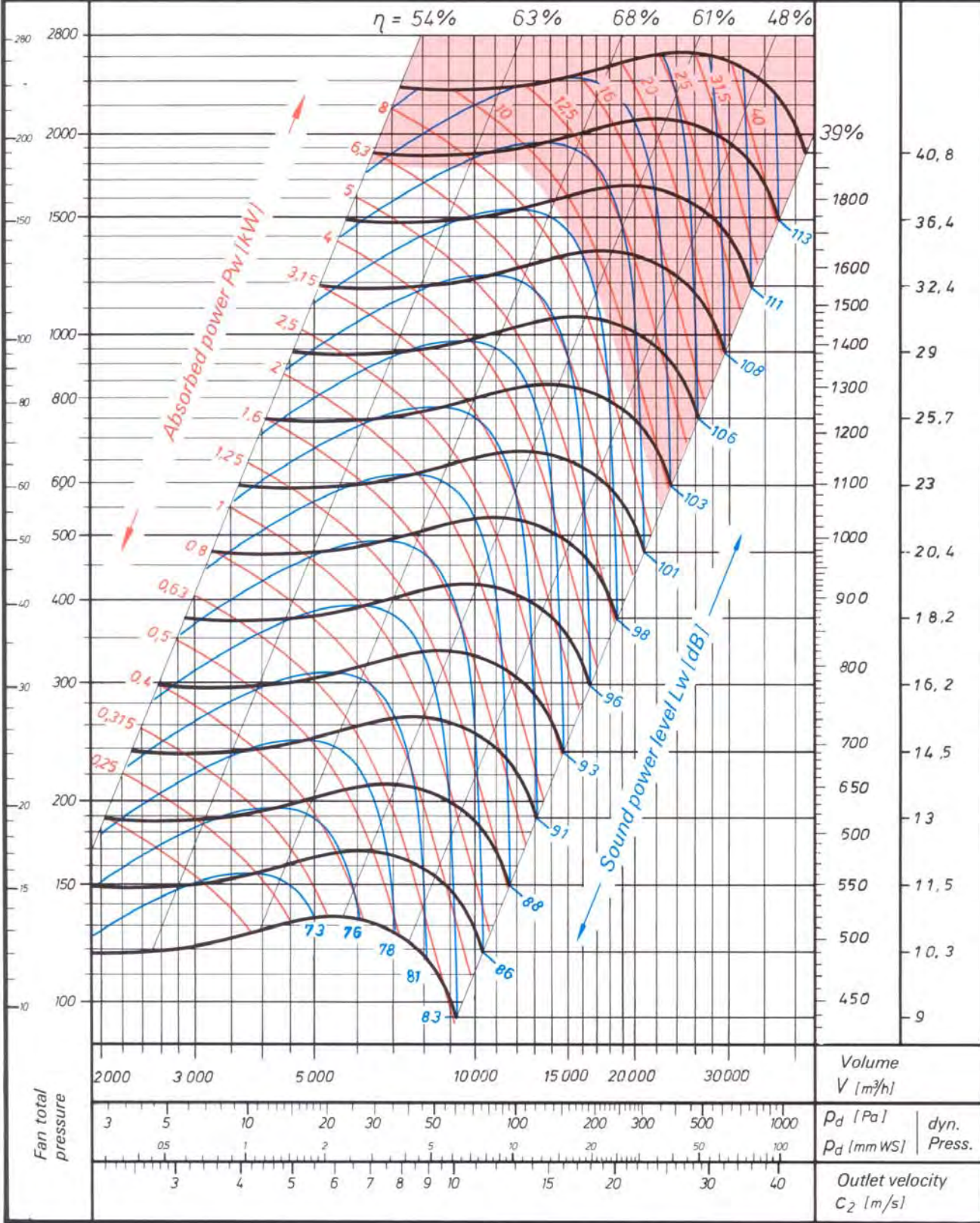

comefri

Radial Fan forward curved double inlet

TLZ 450



Max. speed $n_{max} = 1500 \text{ min}^{-1}$
 Max. shaft power $P_{wmax} = 11 \text{ kW}$
 Max. total pressure $\Delta p_t = 1800 \text{ Pa}$
 Number of blades $z = 42$
 Mass moment of inertia $J (J = \frac{GD^2}{4}) = 0,44 \text{ kgm}^2$

Fan speed $n \text{ (min}^{-1}\text{)}$
 Peripheral speed $u \text{ (m/s)}$

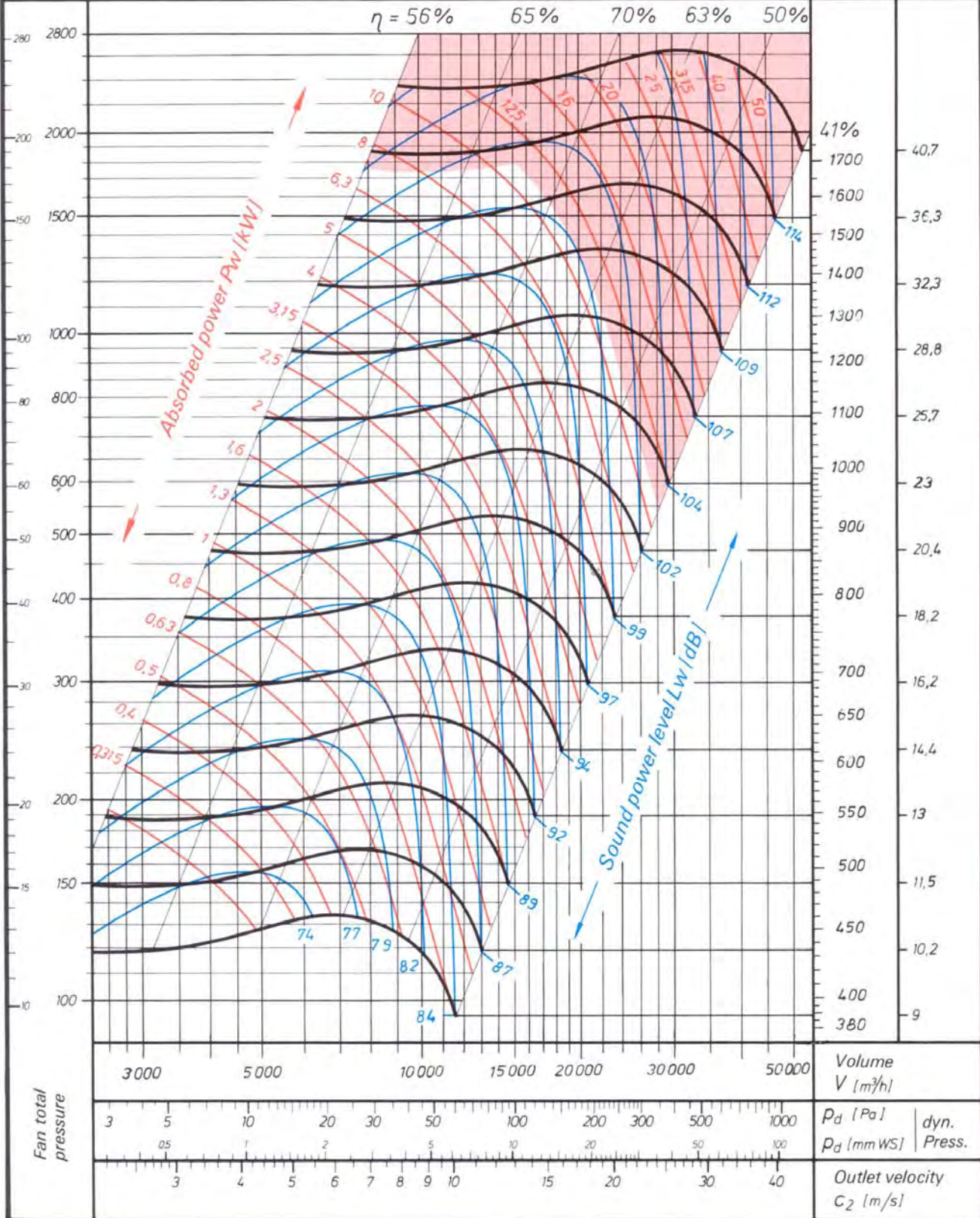

comefri

Radial Fan

forward curved double inlet

TLZ 500



Max. speed
Max. shaft power
Max. total pressure
Number of blades
Mass moment of inertia

$n_{max} = 1300 \text{ min}^{-1}$
 $P_{wmax} = 11 \text{ kW}$
 $\Delta p_t = 1700 \text{ Pa}$
 $z = 38$
 $J (J = \frac{GD^2}{4}) = 0,85 \text{ kgm}^2$

Fan speed
 $n \text{ [min}^{-1}\text{]}$

Peripheral speed
 $u \text{ [m/s]}$

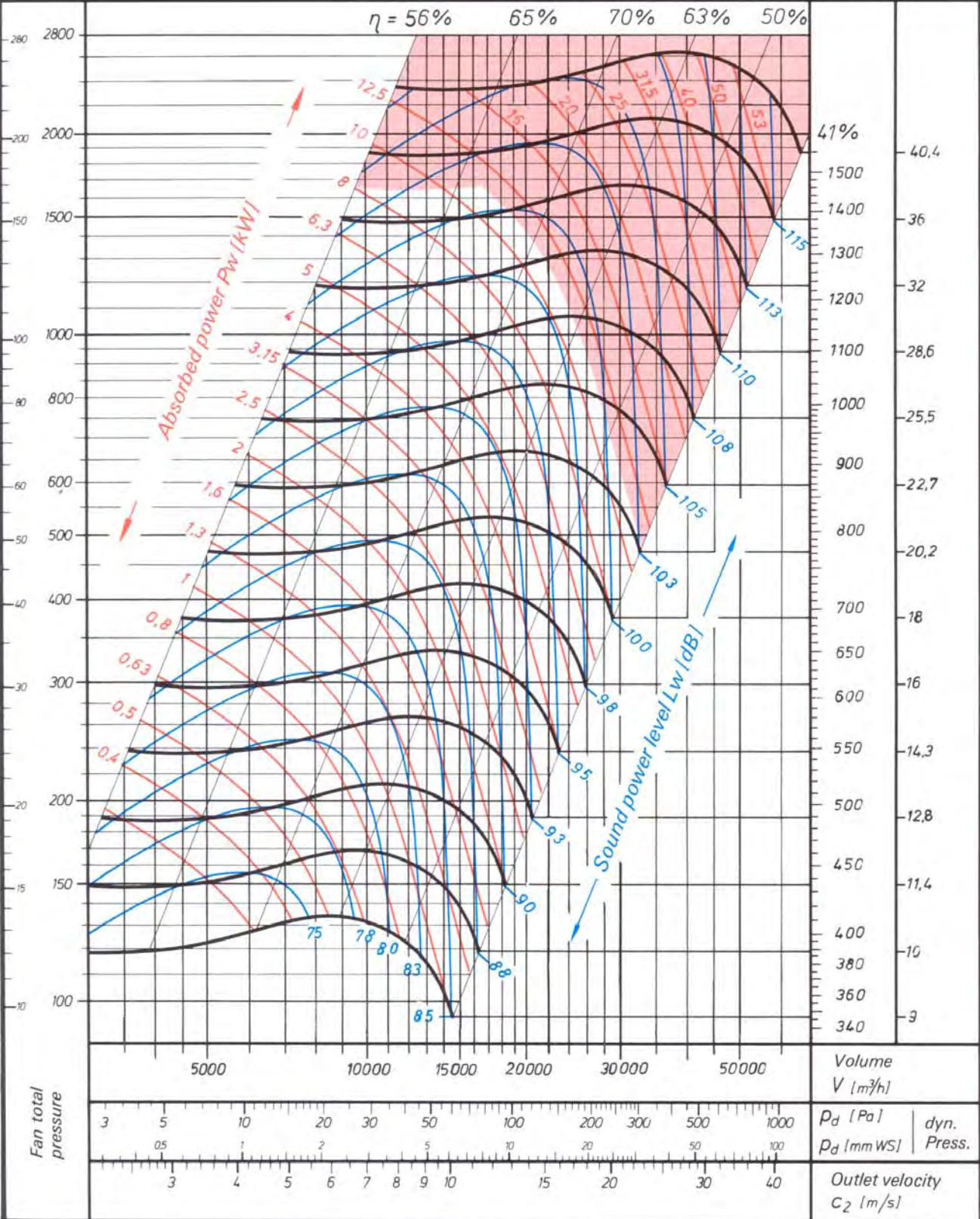



Max. speed
Max. shaft power
Max. total pressure
Number of blades
Mass moment of inertia

$n_{max} = 1200 \text{ min}^{-1}$
 $P_{wmax} = 135 \text{ kW}$
 $\Delta p_t = 1800 \text{ Pa}$
 $z = 42$
 $J (J = \frac{GD^2}{4}) = 1,34 \text{ kgm}^2$

Fan speed
 $n \text{ (min}^{-1}\text{)}$

Peripheral speed
 $u \text{ (m/s)}$

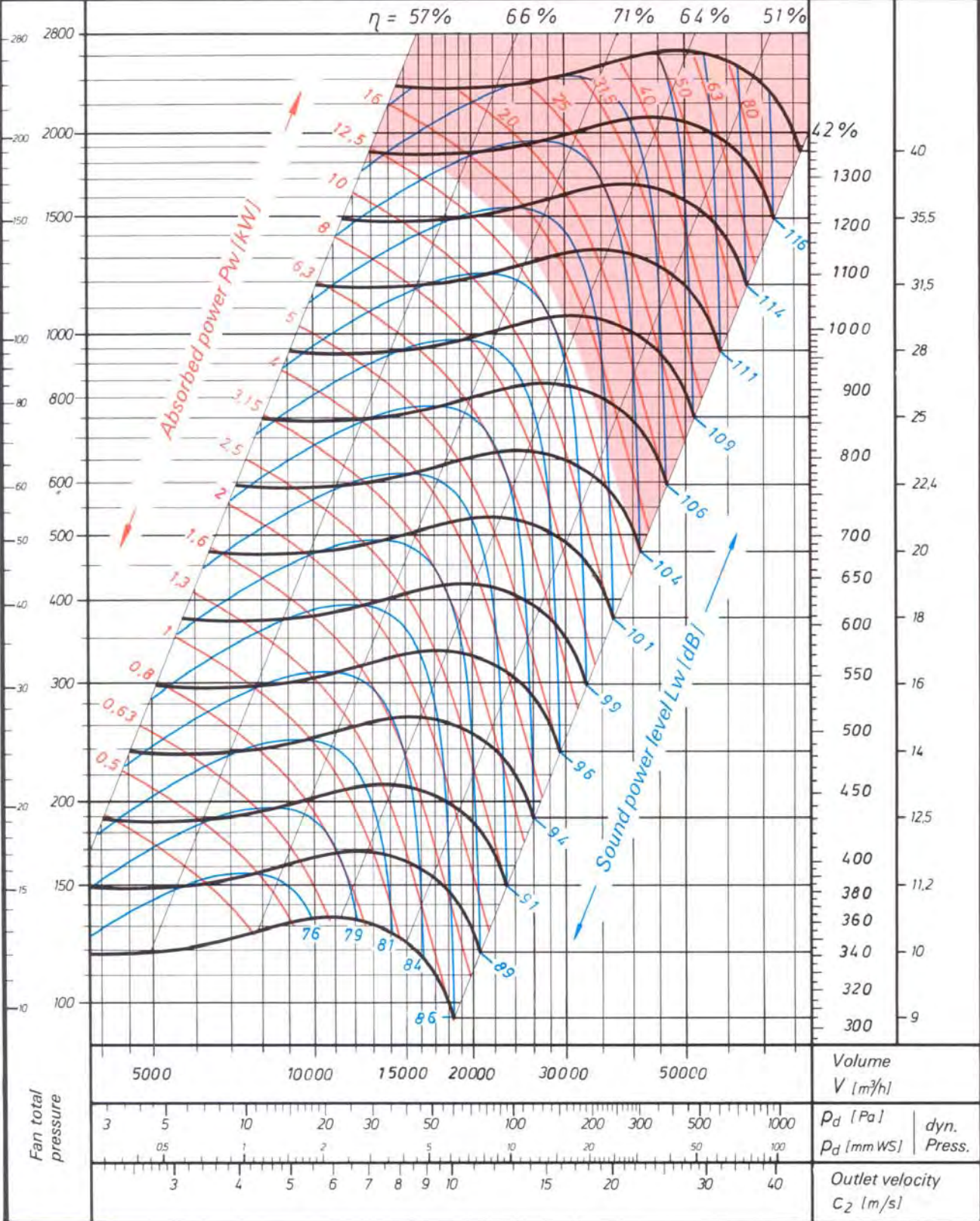

comefri

Radial Fan forward curved double inlet

TLZ 630



Max. speed
Max. shaft power
Max. total pressure
Number of blades
Mass moment of inertia

$n_{max} = 1000 \text{ min}^{-1}$
 $P_{wmax} = 13,5 \text{ kW}$
 $\Delta p_t = 1600 \text{ Pa}$
 $z = 38$
 $J (J = \frac{GD^2}{4}) = 2,2 \text{ kgm}^2$

Fan speed
 $n \text{ (min}^{-1}\text{)}$

Peripheral speed
 $u \text{ (m/s)}$

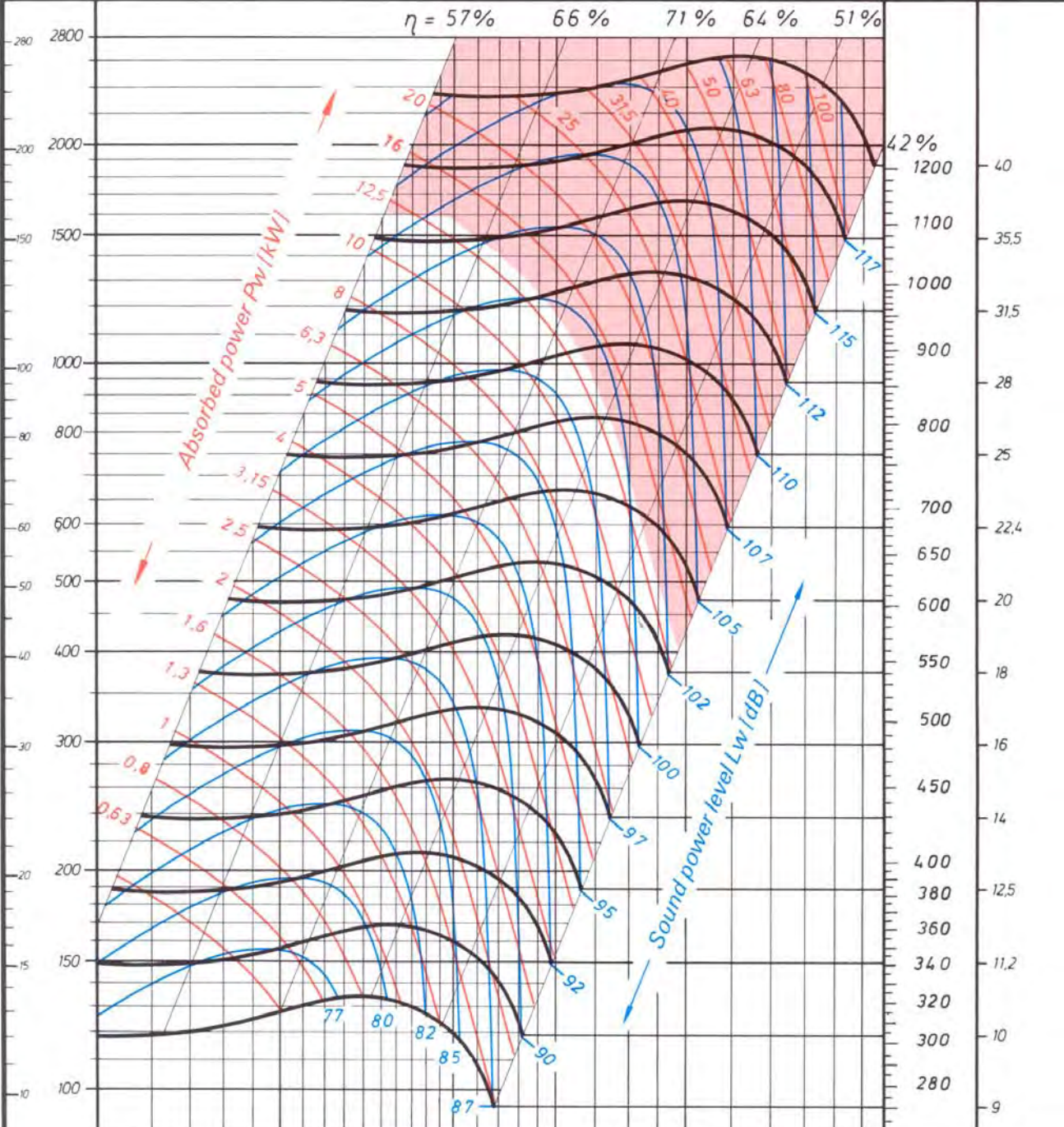

Fan total pressure	10000	15000	20000	30000	50000	100000	Volume $V \text{ (m}^3\text{/h)}$
	3	5	10	20	30	50	$P_d \text{ (Pa)}$
	0.5	1	2	5	10	20	$P_d \text{ (mm WS)}$
	3	4	5	6	7	8	Outlet velocity $C_2 \text{ (m/s)}$
				15	20	30	dyn. Press.
						40	



Max. speed
Max. shaft power
Max. total pressure
Number of blades
Mass moment of inertia

	TLZ 710	710 T
Max. speed	$n_{max} = 750$	850 min^{-1}
Max. shaft power	$P_{wmax} = 14$	22 kW
Max. total pressure	$\Delta p_t = 1200$	1550 Pa
Number of blades	$z = 42$	42
Mass moment of inertia	$J (J = \rho D^2) = 3,4$	$3,4 \text{ kgm}^2$

Fan speed
 $n \text{ (min}^{-1}\text{)}$
Peripheral speed
 $U \text{ (m/s)}$

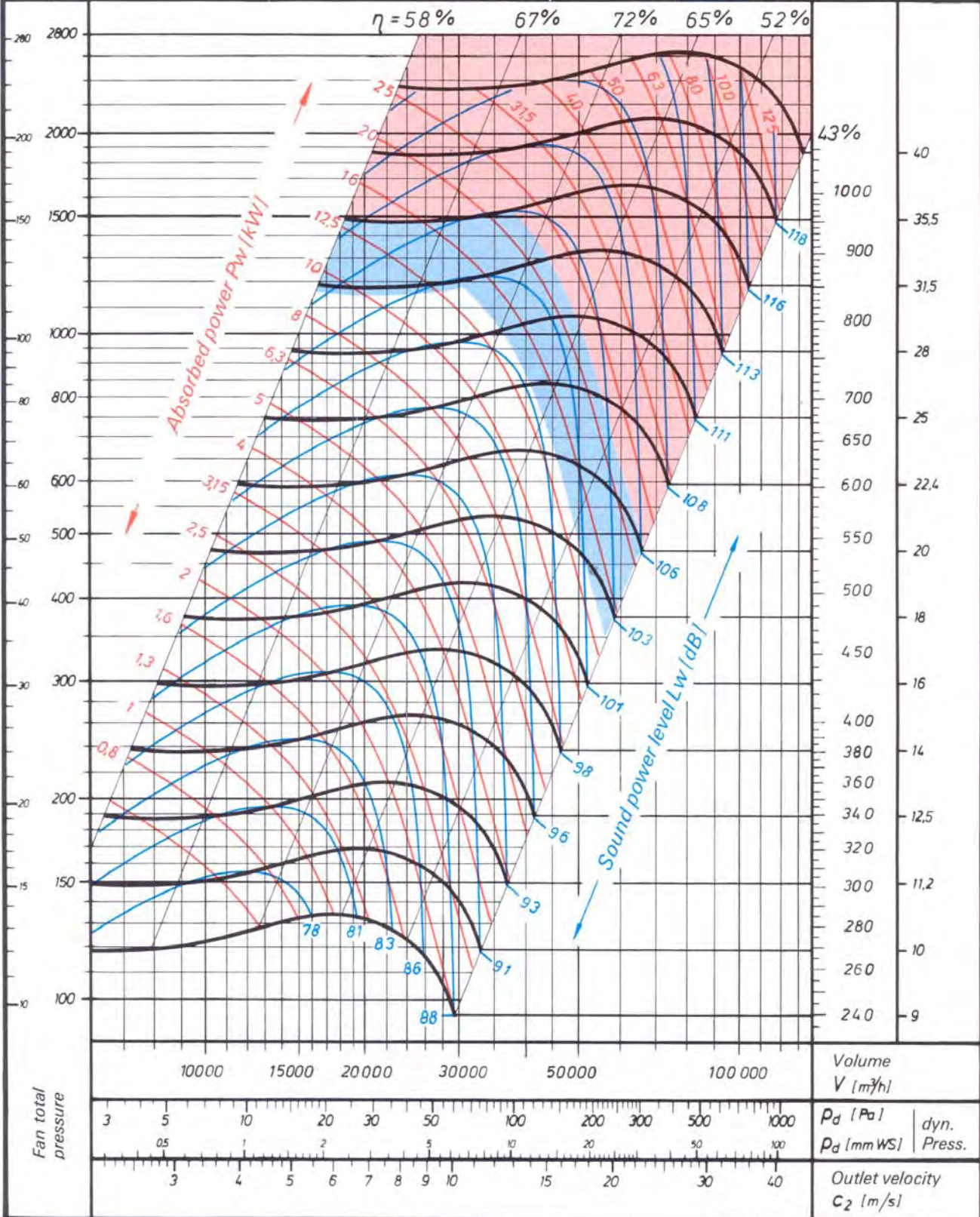

comefri

Radial Fan

forward curved double inlet

TLZ 800 T



Max. speed
Max. shaft power
Max. total pressure
Number of blades
Mass moment of inertia

$n_{max} = 750 \text{ min}^{-1}$
 $P_{wmax} = 25 \text{ kW}$
 $\Delta p_t = 1600 \text{ Pa}$
 $z = 38$
 $(J = \frac{GD^2}{4}) = 5,8 \text{ kgm}^2$

Fan speed
 $n \text{ (min}^{-1}\text{)}$

Peripheral speed
 $U \text{ (m/s)}$

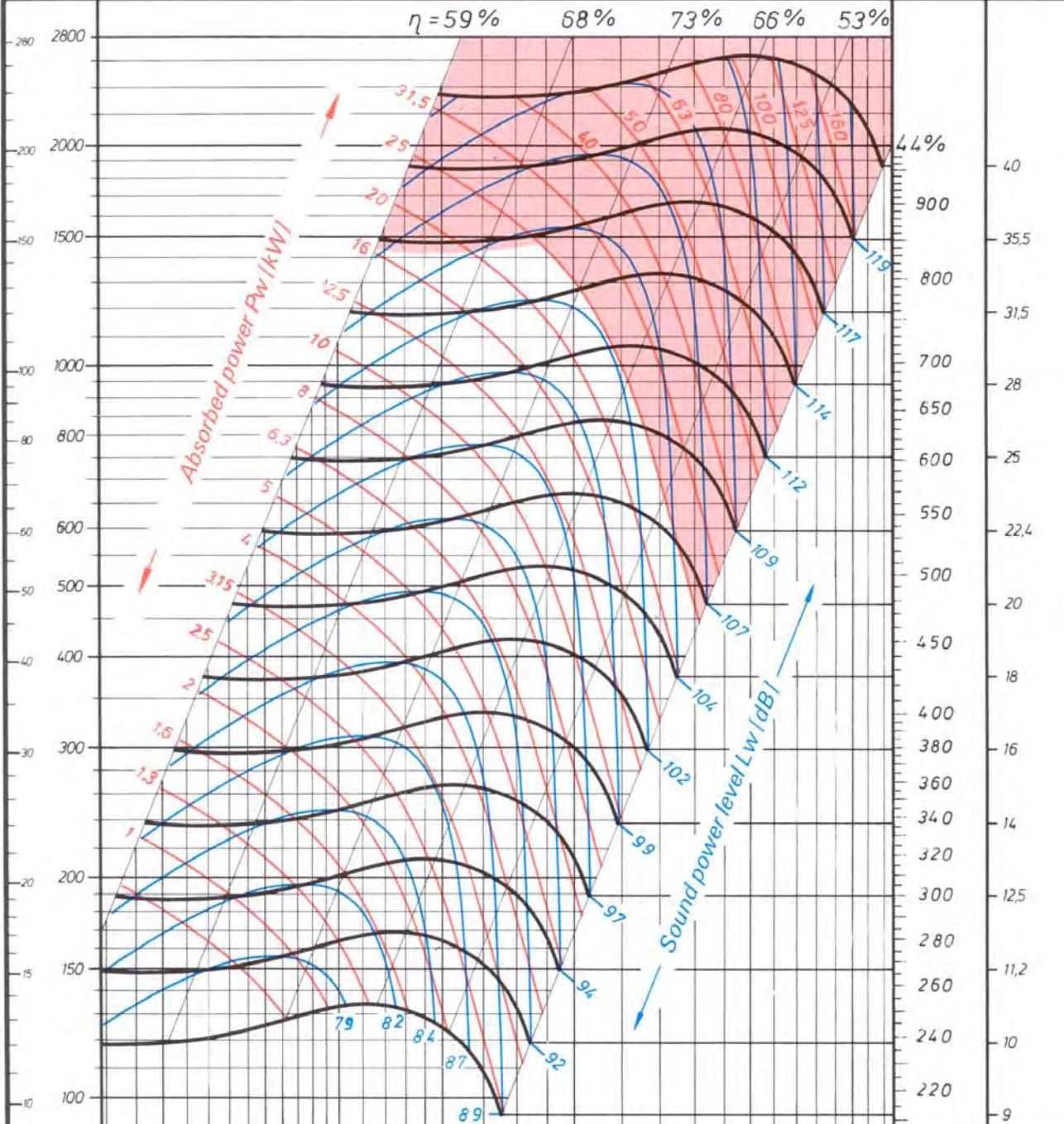

Fan total pressure	Volume $V \text{ (m}^3\text{/h)}$	$P_d \text{ (Pa)}$	dyn. Press.
		$P_d \text{ (mm WS)}$	
	Outlet velocity $C_2 \text{ (m/s)}$		

comefri

Radial Fan forward curved double inlet

TLZ 900 T



Max. speed
Max. shaft power
Max. total pressure
Number of blades
Mass moment of inertia

$n_{max} = 650 \text{ min}^{-1}$
 $P_{wmax} = 32 \text{ kW}$
 $\Delta p_t = 1450 \text{ Pa}$
 $z = 42$
 $J (J = \frac{GD^2}{4}) = 8,9 \text{ kgm}^2$

Fan speed
 $n \text{ (min}^{-1}\text{)}$

Peripheral speed
 $u \text{ (m/s)}$

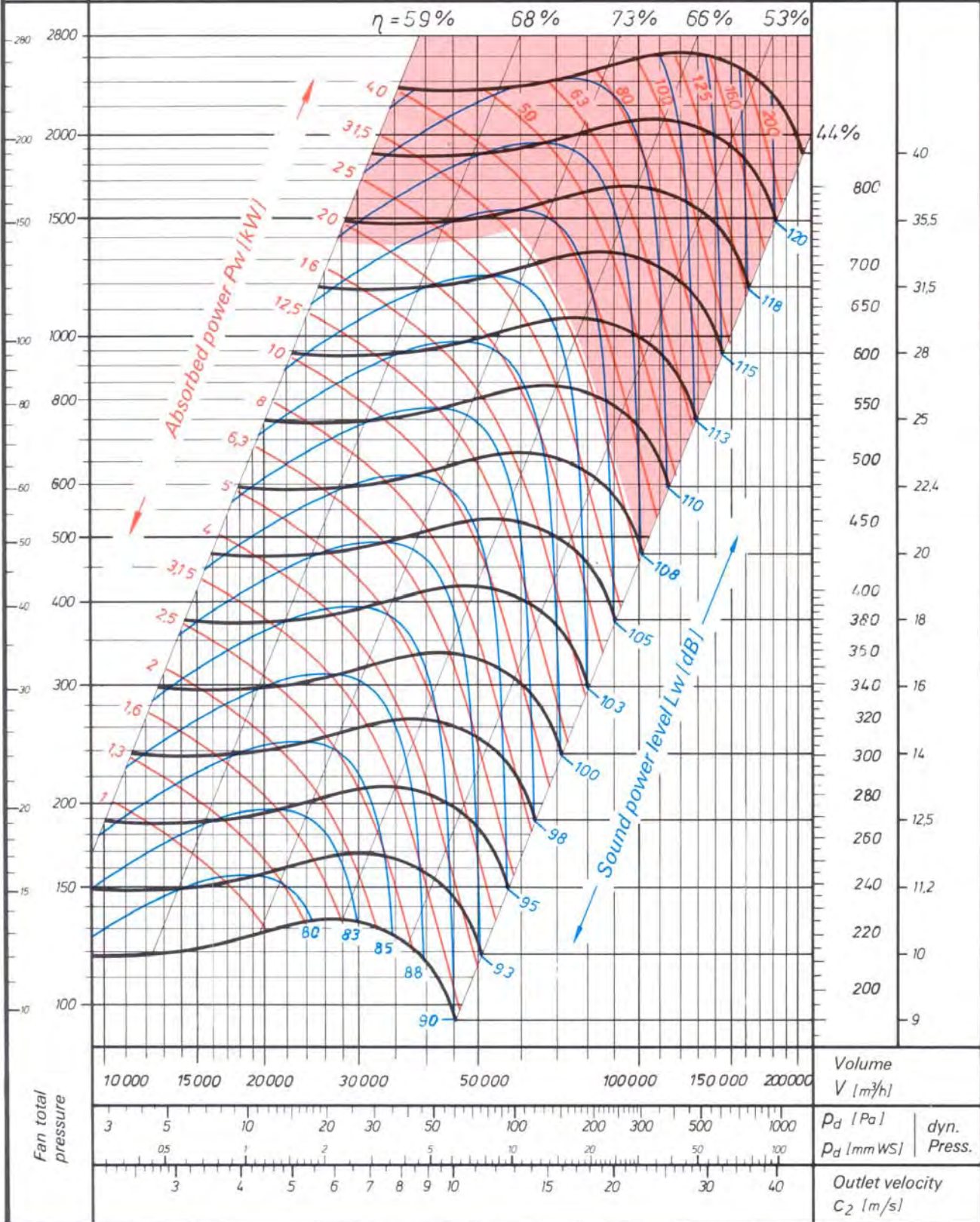

comefri

Radial Fan

forward curved double inlet

TLZ 1000 T



Max. speed $n_{max} = 600 \text{ min}^{-1}$
 Max. shaft power $P_{wmax} = 40 \text{ kW}$
 Max. total pressure $\Delta p_t = 1500 \text{ Pa}$
 Number of blades $z = 48$
 Mass moment of inertia $J (J = \frac{GD^2}{4}) = 13,5 \text{ kgm}^2$

Fan speed $n \text{ (min}^{-1}\text{)}$
 Peripheral speed $U \text{ (m/s)}$

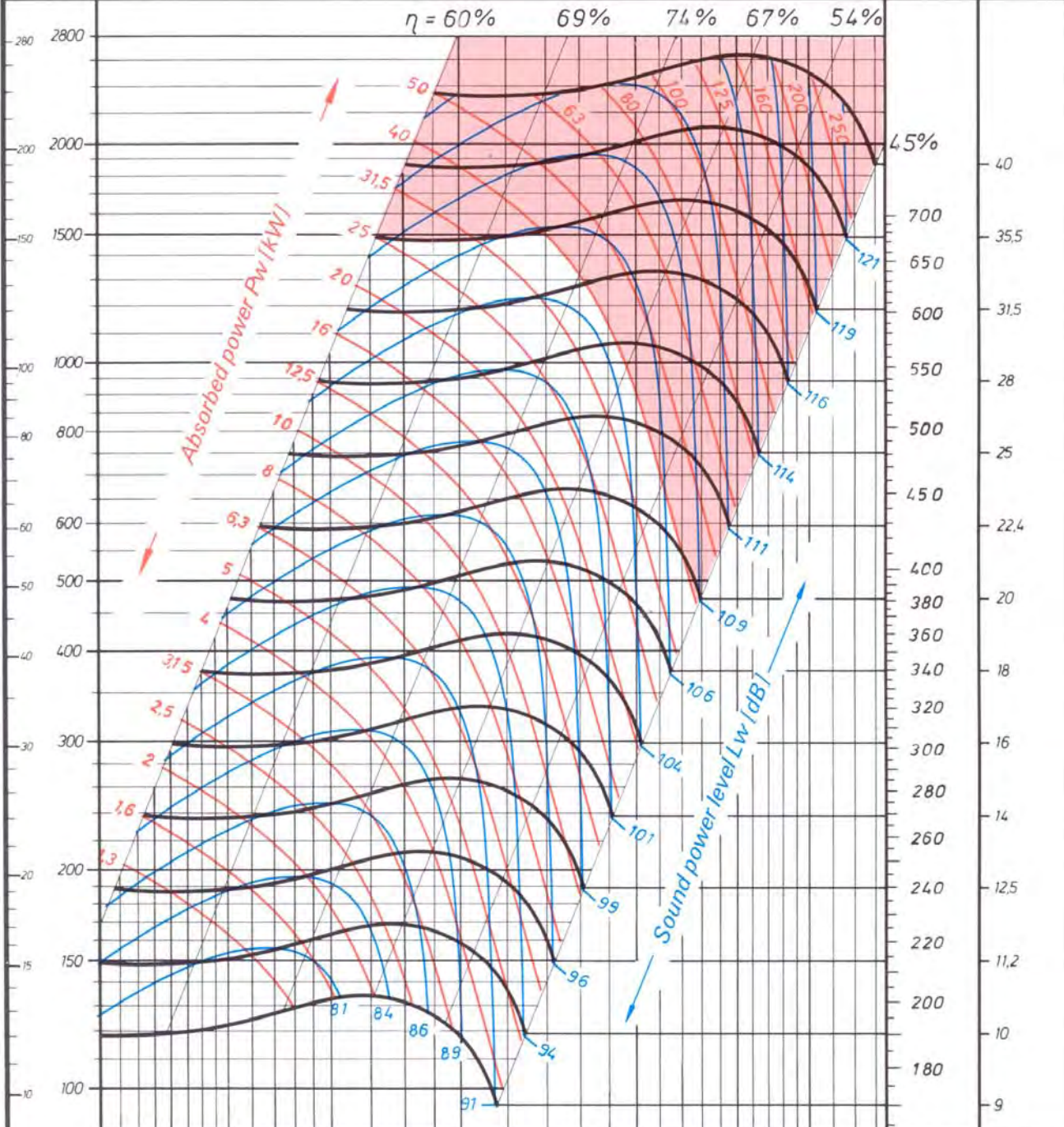

Fan total pressure	Volume $V \text{ (m}^3\text{/h)}$	$P_d \text{ (Pa)}$	dyn. Press.
		$P_d \text{ (mm WS)}$	
		Outlet velocity $C_2 \text{ (m/s)}$	

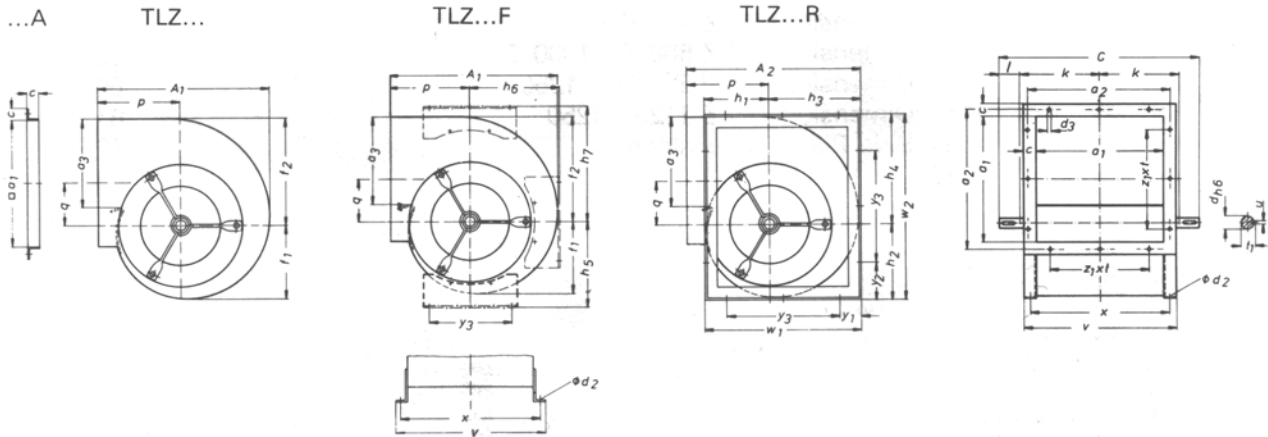

TLZ	A ₁	A ₂	a ₁	a ₂	a ₃	C	c	d ^{h6}	d ₂	d ₃	f ₁	f ₂	h ₁	h ₂	h ₃	h ₄	h ₅
160	282,5	285	205	230	131	345	25	20	7	7,5	120	153	109	121	145	177	150
180	316,5	319	229	259	149	375	25	20	7	7,5	136	195	119	138	167	200	164
200	342	344	256	286	163	405	25	20	7	7,5	149	216	133	152	180	220	181
225	380	382	288	318	180	435	25	20	7	7,5	167	243	146	169	202	246	197
250	422	420	322	352	199	470	25	20	7	7,5	186	269	159	188	225	273	210
280	464	467	361	391	228	540	25	25	10,5	7,5	208	302	180	211	252	307	233
315	519	519	404	434	240	585	25	25	10,5	7,5	232	341	197	235	283	343	258
355	582	580	453	483	311	655	25	30	10,5	7,5	265	383	222	266	319	389	274
400	645	651	507	537	336	709	25	30	10,5	7,5	295	432	245	300	361	436	302
450	722	722	569	599	382	810	25	35	12	7,5	330	485	270	336	404	492	336
500	795	801	638	668	450	875	25	35	12	7,5	366	538	295	374	449	544	375
560	886	893	715	745	502	1000	25	40	15	7,5	411	601	335	419	503	611	416
630	992	1000	801	831	559	1090	25	40	15	7,5	463	679	370	471	566	687	468
710	1114	1120	898	928	624	1220	25	50	17	7,5	521	765	412	531	636	773	531

TLZ	h ₆	h ₇	k	l	p	q	t ₁	u	v	w ₁	w ₂	x	y ₁	y ₂	y ₃	z ₁ x t
160	149	204	134	38,5	139,5	71	22,5	6	256	254	298	231	47	69	180	2 x 90
180	164	224	146	41,5	152,5	81	22,5	6	280	286	338	255	53	79	180	2 x 90
200	184	245	162	40,5	164	89	22,5	6	307	314	372	282	45	74	224	2 x 90
225	204	274	178	39,5	180	100	22,5	6	339	348	416	314	62	96	224	3 x 90
250	227	299	195	40	195	109	22,5	6	373	384	462	348	80	119	224	3 x 90
280	252	328	217	53	215	123	28	8	422	432	518	392	76	119	280	3 x 90
315	280	367	239	53	236	139	28	8	466	480	578	436	100	149	280	4 x 90
355	320	411	267	60	261	158	33	8	534	542	655	494	94	150	355	4 x 90
400	359	462	293	61,5	290	179	33	8	588	606	736	549	126	191	355	5 x 90
450	407	518	330	75	322	202	38	10	651	674	828	611	112	189	450	6 x 90
500	448	568	364	73	352	221	38	10	720	744	918	681	147	234	450	6 x 90
560	502	634	406	94	390	248	43	12	818	838	1030	768	169	265	500	7 x 90
630	571	707	450	95	434	280	43	12	904	936	1158	854	188	299	560	8 x 90
710	636	797	497	119	485	318	53,5	14	1001	1048	1304	961	209	337	630	9 x 90

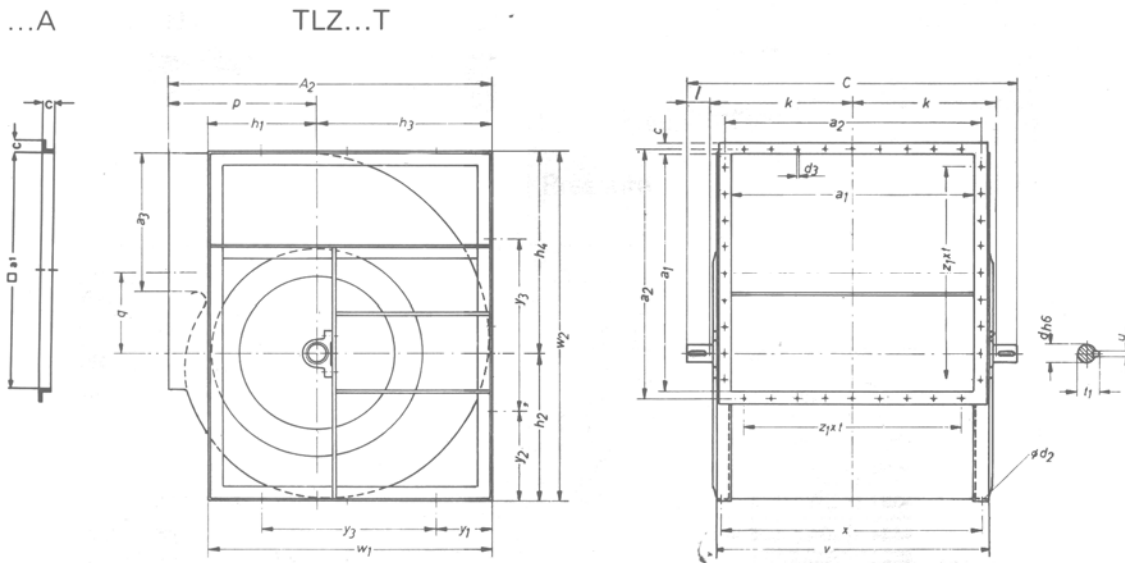

TLZ	A ₂	a ₁	a ₂	a ₃	C	c	d ^{h6}	d ₂	d ₃	h ₁	h ₂	h ₃	h ₄	k
710	1120	898	928	624	1260	25	50	18	7,5	413	531	635	773	516
800	1256	1007	1037	714	1367	25	50	18	7,5	458	597	716	871	570
900	1409	1130	1164	806	1529	30	60	18	10	507	670	805	978	639
1000	1541	1267	1301	909	1666	30	60	18	10	560	735	884	1075	708

TLZ	l	p	q	t ₁	u	v	w ₁	w ₂	x	y ₁	y ₂	y ₃	z ₁ x t
710	114	485	318	53,5	14	1001	1048	1304	961	209	327	630	9 x 90
800	13	540	359	53,5	14	1111	1174	1468	1071	232	379	710	11 x 90
900	125,5	604	406	64	18	1234	1312	1648	1194	256	424	800	11 x 100
1000	125	657	433	64	18	1371	1444	1810	1331	272	455	900	12 x 100

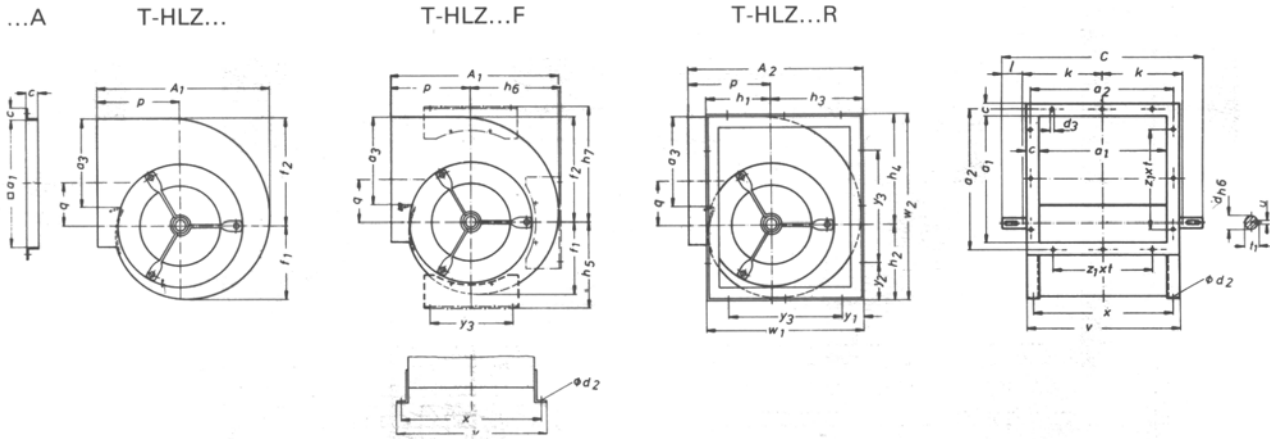

TLZ	A ₁	A ₂	a ₁	a ₂	a ₃	C	c	d ^{h6}	d ₂	d ₃	f ₁	f ₂	h ₁	h ₂	h ₃	h ₄	h ₅
180	316,5	319	229	259	185	375	25	20	7	7,5	136	195	119	138	167	200	164
200	342	344	256	286	166	405	25	20	7	7,5	149	216	133	152	180	220	181
225	380	382	288	318	230	435	25	20	7	7,5	167	243	146	169	202	246	197
250	422	420	322	352	193	470	25	20	7	7,5	186	269	159	188	225	273	210
280	464	467	361	391	227	540	25	25	10,5	7,5	208	302	180	211	252	307	233
315	519	519	404	434	243	585	25	25	10,5	7,5	232	341	197	235	283	343	258
355	582	580	453	483	275	655	25	30	10,5	7,5	265	383	222	266	319	389	274
400	645	651	507	537	305	709	25	30	10,5	7,5	295	432	245	300	361	436	302
450	722	722	569	599	306	810	25	35	12	7,5	330	485	270	336	404	492	336

TLZ	h ₆	h ₇	k	l	p	q	t ₁	u	v	w ₁	w ₂	x	y ₁	y ₂	y ₃	z ₁ x t
180	164	224	146	41,5	152,5	81	22,5	6	280	286	338	255	53	79	180	2 x 90
200	184	245	162	40,5	164	89	22,5	6	307	314	372	282	45	74	224	2 x 90
225	204	274	178	39,5	180	100	22,5	6	339	348	416	314	62	96	224	3 x 90
250	227	299	195	40	195	109	22,5	6	373	384	462	348	80	119	224	3 x 90
280	252	328	217	53	215	123	28	8	422	432	518	392	76	119	280	3 x 90
315	280	367	239	53	236	139	28	8	466	480	578	436	100	149	280	4 x 90
355	320	411	267	60	261	158	33	8	534	542	655	494	94	150	355	4 x 90
400	359	462	293	61,5	290	179	33	8	588	606	736	549	126	191	355	5 x 90
450	407	518	330	75	322	202	38	10	651	674	828	611	112	189	450	6 x 90

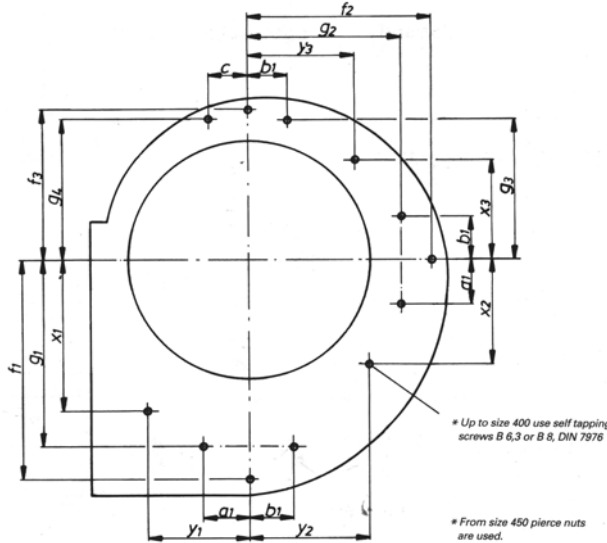

Fan size		a ₁	b ₁	c	f ₁	f ₂	f ₃	g ₁	g ₂	g ₃	g ₄	x ₁	x ₂	x ₃	y ₁	y ₂	y ₃	*	
TLZ	THLZ																		
160	-	30	30	30	-	-	-	155	101	101	101	121	92	67	92	67	92	B 6,3	
180	180	30	30	30	-	-	-	175	115	115	115	141	92	81	92	81	92	B 6,3	
200	200	40	40	40	202	163	134	190	129	126	126	155	110	91	110	94	110	B 6,3	
225	225	40	40	40	229	185	152	219	149	142	142	184	110	107	110	114	110	B 6,3	
250	250	40	40	40	256	208	171	244	172	155	155	209	110	120	110	137	110	B 6,3	
280	280	113	113	71	287	233	191	245	169	150	170	-	-	-	-	-	-	B 8	
315	315	113	113	71	323	263	215	284	197	175	195	-	-	-	-	-	-	B 8	
355	355	156	156	156	364	295	241	295	204	158	158	197,5	-	-	197,5	-	-	B 8	
400	400	156	156	156	411	336	275	346	243	186	186	220	-	-	220	-	-	B 8	
450	450	213	213	213	466	379	311	350	271	168	168	245	-	-	245	-	-	M 10	
500	-	213	213	213	519	423	349	400	280	207	207	270	-	-	270	-	-	M 10	
560	-	235	235	235	581	472	389	494	362	276	276	305	-	-	305	-	-	M 12	
630	-	235	235	235	656	535	441	567	431	328	328	340	-	-	340	-	-	M 12	
710	-	265	265	265	717	601	496	637	476	371	371	377,5	-	-	377,5	-	-	M 12	

TLZ and THLZ Fan and accessories weights (in Kg)

Table 6.5

Fan size	TLZ	TLZ...T	THLZ	THLZ...T	Inlet vane control	Feet	Frame	Outlet flange
160	5.1	-	-	-	-	0.5	0.5	0.66
180	6.0	-	6.3	-	-	0.5	0.5	0.72
200	7.2	-	7.2	-	-	0.8	0.8	0.80
225	8.5	-	8.2	-	-	0.8	0.8	0.88
250	10.8	-	10.2	-	-	0.8	0.8	0.97
280	14.5	-	14.2	-	-	1.0	1.0	1.07
315	20.0	-	19.4	-	12	1.0	1.0	1.20
355	26.5	-	26.3	-	14	2.0	2.0	1.35
400	32.0	-	31.5	-	18	2.0	2.0	1.50
450	42.0	-	41.2	-	21	3.7	3.7	1.70
500	56.0	-	-	-	-	3.7	3.7	1.90
560	76.0	-	-	-	-	7.5	7.5	2.00
630	96.0	-	-	-	-	7.5	7.5	2.30
710	125	190	-	208	-	11.0	11.0	2.60
800	-	230	-	249	-	-	-	2.90
900	-	288	-	321	-	-	-	3.90
1000	-	333	-	380	-	-	-	4.40

7. Fan Discharge and Accessory Position

The following positions are in accordance with Eurovent 1/1.

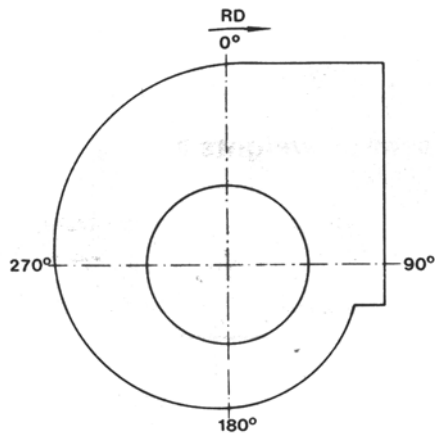

Pic 16

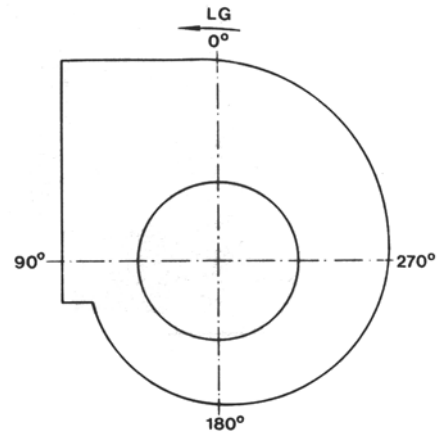

Pic 17

- 7.1 Pic16 and 17 show right hand (RD) and left hand (LG) fans. Fan rotation is always decided when looking from the drive side, i.e. that coupled with the motor. Fan discharges are therefore always described by either RD ...or LG ... followed by the required outlet position (i.e. 90°).
- 7.2 Positions of accessories are described similarly, viewed from the drive side. (see 7.4 and pic 16/17).
- 7.3 When inlet vane controls are specified it is essential to state the position of the actuating arm, see 7.4.
- 7.4 Example of fan discharge and accessory position:
Fan discharge LG 0°
Inspection door 135°
Drain 180°
IVC control 270°

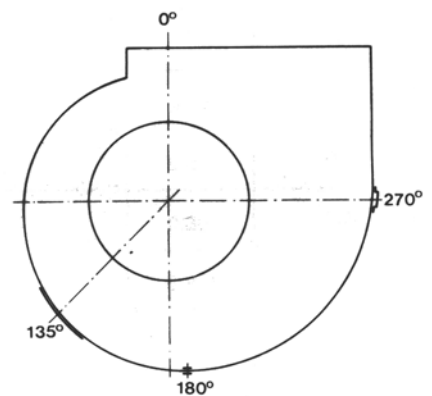

Pic 18

8. Instructions for Ordering and Specifying

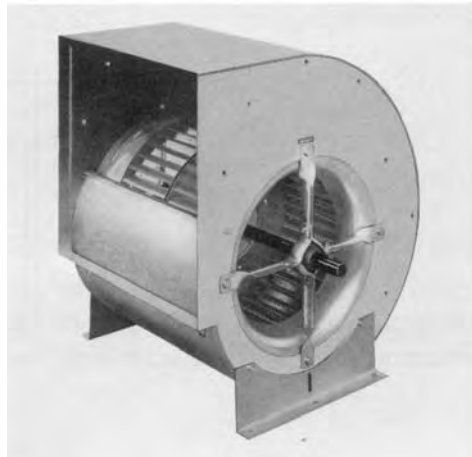

Pic 19
Radial Fan TLZ 400 F

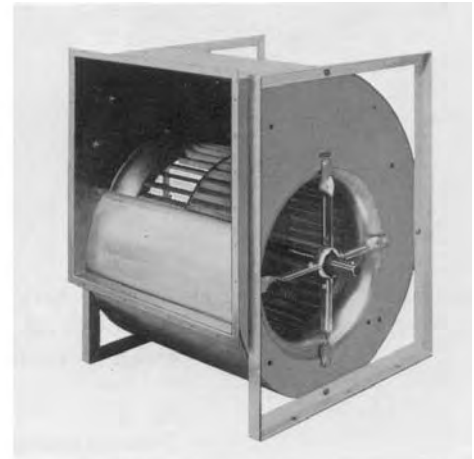

Pic 20
Radial Fan TLZ 500 R

8.1 All standard fans are detailed on drawings 6.1, 6.2 and 6.3.

To order or specify fans they must be described as follows:

Fan range either TLZ, THLZ

Fan size which represents the diameter of impellers in mm (i.e. TLZ 450 or THLZ 450).

8.2 Accessories are represented by the following symbols:

- F = Feet
- A = Outlet flange
- R = Fan frame
- Dr = Inlet vane control
- I = Inspection door
- K = Condensation drain
- Ex = Anti-Spark Feature

Fan accessories should be specified when ordering fans.

Example 1 (see Pic 19):

Fan TLZ 400 with feet TLZ 400 F

Example 2 (see Pic 20):

Fan TLZ 500 with outlet flange and fan frame TLZ 500 RA

8.3 Fan sizes TLZ 710 and THLZ 450 can be supplied as standard with or without frames. see (6.1 and 6.3)

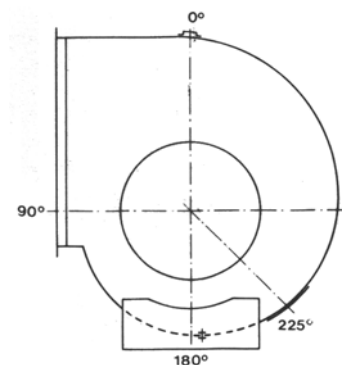

Pic 21
Ordering Example.

8.4 Ordering Example

To order a THLZ 355 with discharge position LG 90° plus feet, outlet flange, inspection door, drain and inlet vane control.

Order as follows:

THLZ 355 A - LG 90° I 225° Dr 0° K 180° F-355

The fans described in this catalogue are suitable for many and varied applications; but should you require special versions a complete technical team exists to assist and advise.

Due to improvements which are introduced from time to time the company reserves the right to alter the products specified in this catalogue.

COMEFRI reserves the right to make any dimensional design changes which are part of their improvement programme. Necessary corrections are updated on our AEOLUS PLUS selection program.

Note:

This catalogue has to be used only for pre-selections. A detailed selection is available from our AEOLUS PLUS selection program.

Comefri SpA

Via Buja, 3
I-33010 Magnano in Riviera (UD)
Italy
Tel. +39-0432-798811
Fax +39-0432-783378
www.comefri.com
E-mail: info@comefri.com

Comefri UK Ltd

Carters Lane, 8 Kiln Farm
Milton Keynes, MK11 3 ER
Great Britain
Tel. +44-1908-56 94 69
Fax +44-1908-56 75 66
www.comefri.com
E-mail: sales@comefri.co.uk

Comefri GmbH

Landshuter Str.55
84030 Ergolding
Germany
Tel. +49-871-43070-0
Fax +49-871-43070-40
www.comefri.de
E-mail: info@comefri.de

Comefri Nordisk ApS

Mileparken, 18
DK 2740 Skovlunde
Denmark
Tel. +45-44-92 76 00
Fax +45-44-92 55 33
www.comefri.com
E-mail: mail.dk@comefri.com

Comefri France S.A.

10, Rue des Frères Lumière
69740 Genas
France
Tel. +33-4-72 79 03 80
Fax +33-4-78 90 69 73
www.comefri.com
E-mail: info@comefrifrance.fr

Comefri USA, Inc

330 Bill Bryan Boulevard
Hopkinsville, KY 42240
USA
Tel. +1-270-881-1444
Fax + 1-270-889-0309
www.comefriusa.com
E-mail: sales@comefriusa.com

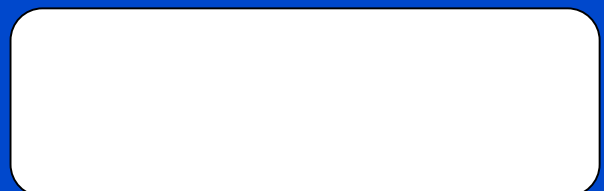

Cat. C-0024 April 2008