

INDUSTRIAL RADIAL FANS DOUBLE INLET



comefri

comefri

TABLE OF CONTENTS

	Page
1. General description	2
2. Series description	3
3. Design execution and settings	4
4. Rotation, discharge position and accessories position	5
5. Drive layout	6
6. Motor selection	6
7. Labelling of fan components	7
8. Spark protection	8
9. Cast-iron bearings	9
10. Inlet vane control	10
11. Fan selection example	12
12. Temperature correction factors	13
13. Sound data	14
14. Transmission losses	15
15. Order example	15
16. Test laboratory	16
17. BCZ 25 double inlet industrial radial fan	17
BCZ 25/400÷1000 discharge position	18
BCZ 25/400÷1000 dimensions	19
BCZ 25/1120÷2000 discharge position	20
BCZ 25/1120÷2000 dimensions	22
18. Performance curves	23
19. Accessories	39
Damper, flexible outlet connection, drain plug	40
Inspection door, inlet and outlet guards	41
Belt-guard, shaft guard, anti-vibration mounts	42
Inlet vane control	43
Base frame	44
20. Weights	46
21. Custom-made executions	47
22. Completed order example	48

comefri

1. GENERAL DESCRIPTION

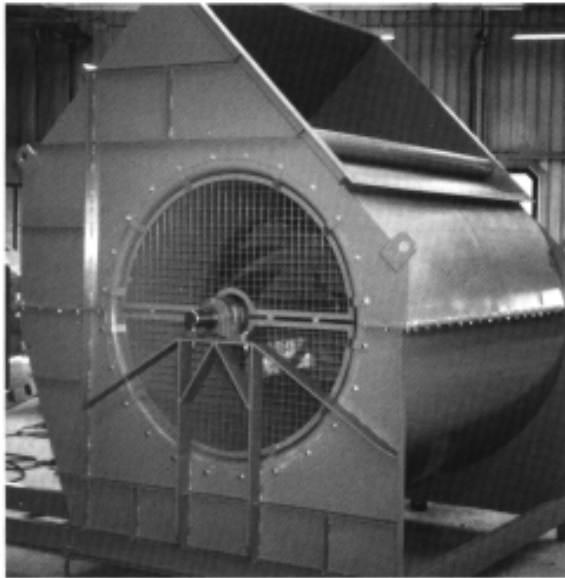

The BCZ 25 double inlet industrial radial fan series has been developed by COMEFRI in such a way that, even with standard components at disposal, customers with special requirements can be taken into consideration.

COMEFRI industrial BCZ 25 fans, developed with CAD systems, are designed with the following characteristics:

- compact design
- versatile applications
- high efficiency
- standardization of components
- maximum volume of up to 700000 m³/h (in standard execution)
- maximum total pressure up to 3500 Pa ($\rho = 1,2 \text{ kg/m}^3$, $t = 20^\circ\text{C}$, in standard execution)

comefri

2. SERIES DESCRIPTION

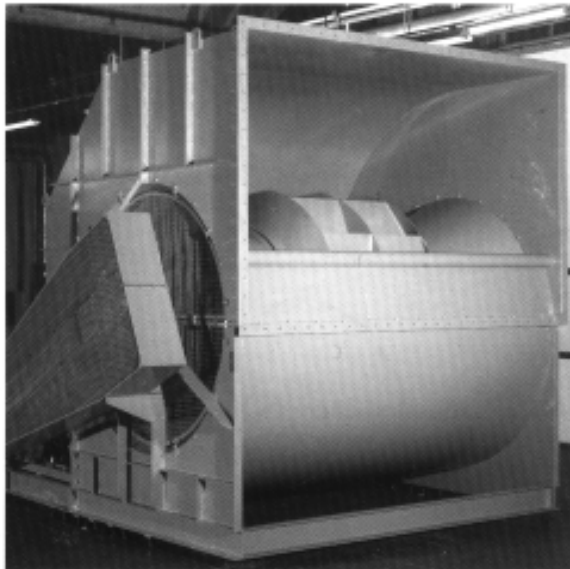

BCZ 25 - Air flow up to 700000 m³/h,
total pressure up to 3500 Pa

General: The single inlet industrial radial fans series BCZ 25 with backward curved blades, are suited for applications for both clean and slightly dusty air with temperatures of up to 100°C. To reach high performance levels, components are constructed in geometrically optimal forms. The air flow of this series in standard execution reaches 700000 m³/h, with total pressures up to 3500 Pa. In addition, these machines are designed to operate at a low noise level and with high efficiency. The sizes follow geometrical gradations according to the series standard R 20. The nominal size corresponds to the outside diameter of the impeller.

Casing: The spiral shaped casings are continuously welded for this series. They are manufactured in steel, which are suitably reinforced for industrial, heavy duty applications.

Furthermore, all standard casing sizes up to size 1000 can be set in any one of 8 discharge positions. Outlet flanges are incorporated as standard (DIN 24 159 page 3). Upon request, the housing can also be ordered in splitted execution.

Impeller: From the nominal size 400 upwards, these series are finished and equipped with backwards curved, continuously welded steel blades. The impellers are balanced statically and dynamically on precision machinery in accordance with quality levels Q 6,3 (VDI 2060), and upon request to Q 2,5. In addition, a balance certificate can be made available directly from the balancing machine.

Fan Inlet: The fan inlet has been aerodynamically designed and guarantees an optimal airflow path towards the impeller. Perfect alignment is guaranteed between the inlet cone and the impeller.

Bearings: The bearings housing are of cast iron plummer block design incorporating ball/spherical roller bearing races to give excellent bearing life.

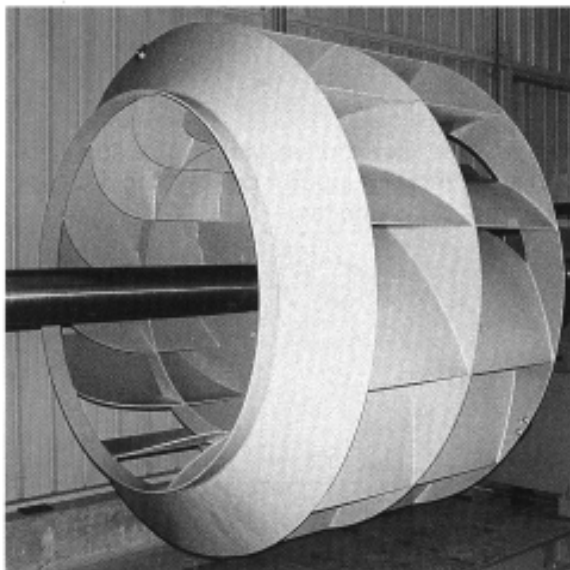

comefri

3. DESIGN EXECUTION AND SETTINGS

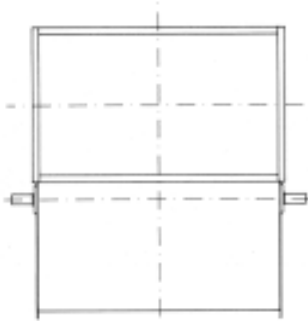

Setting 3D

Double inlet - belt drive - ball bearing support on both sides of the fan.

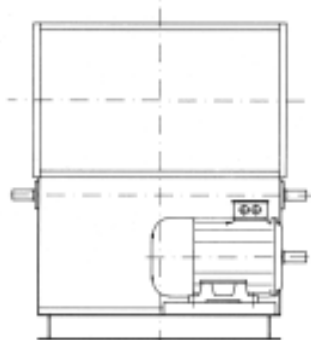

Setting 11D

Double inlet - belt drive - ball bearing support on both sides of the fan - fan and motor on a common base frame.

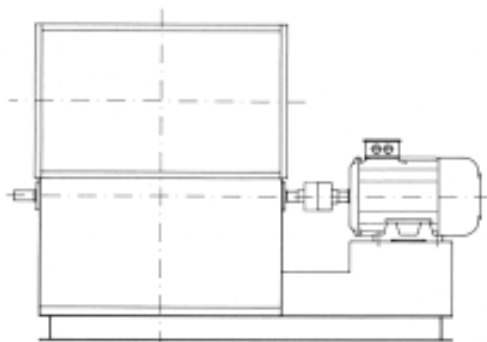

Setting 7D

Double inlet - direct drive with flexible coupling, additional motor support - ball bearing support on both sides of the fan.

comefri



4. ROTATION, DISCHARGE POSITION AND ACCESSORIES POSITION

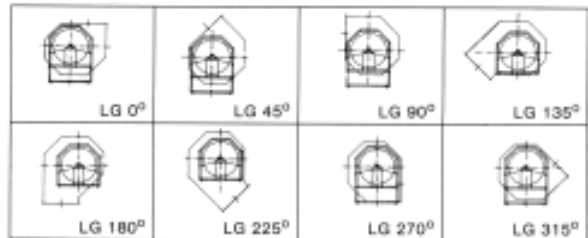
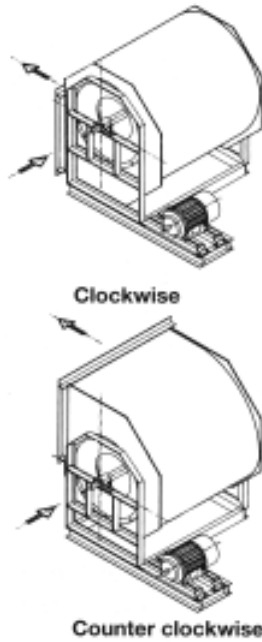

Rotation and Discharge Position

The rotation of the fan viewed from the drive side is:

- a) clockwise, if indicated with the symbol RD or
- b) counter-clockwise, if indicated with the symbol LG.

The radial fan's discharge position is determined by the outlet position. This is indicated firstly, by the rotation symbol (RD or LG) and secondly, by the angle with respect to the line of reference perpendicular to the mounting surface (eg. RD 90°).

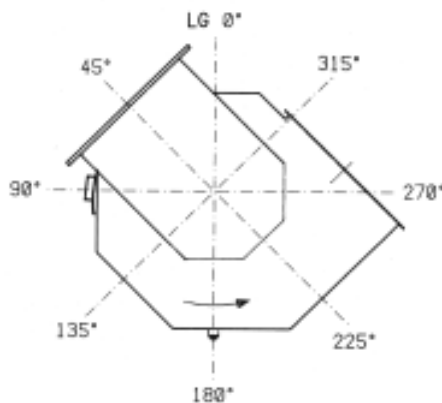

Accessories Position

The positions of an inlet box, an inspection door, or other accessories are indicated by the rotation symbol RD or LG and by the angle measured in degrees, with respect to the line of reference perpendicular to the mounting surface and the position of each respective accessory.

Example: Fan LG 315°
 Drain plug 180°
 Inspection door 90°
 Inlet box 45°

comefri

5. DRIVE LAYOUT

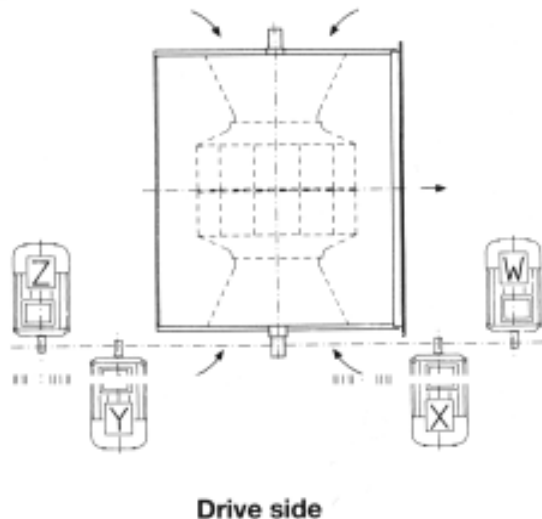

The layout of the motor, indicated by the symbols W, X, Y, Z is seen perpendicular to the mounting surface of the fan.

In standard execution the motor can be mounted in layout W or Z.

N.B. The rotation of the fan is determined by looking at the drive side of the fan.

6. MAXIMUM ALLOWABLE MOTOR SIZES FOR SETTINGS 4 AND 9 MOTOR SELECTION

With the selection of the motor, it must be verified whether the time required to accelerate the impeller from a stationary position remains within the allowable tolerances specified by the motor manufacturer.

The acceleration time "t_a" can be approximated using the following formula:

$$t_a \approx 0.8 \frac{J \cdot n^2}{P_M} \cdot 10^{-5}$$

J = moment of inertia in kgm²

n = fan speed in min⁻¹

P_M = motor power in kW

In the event that "t_a" exceeds the maximum allowable start-up indicated by the motor manufacturer, i.e. the maximum start-up exceeds the release time for the motor protection switch, a more powerful motor must be used. The protection switch should be calculated for heavy-duty start-ups.

comefri

7. NOMENCLATURE OF FAN COMPONENTS

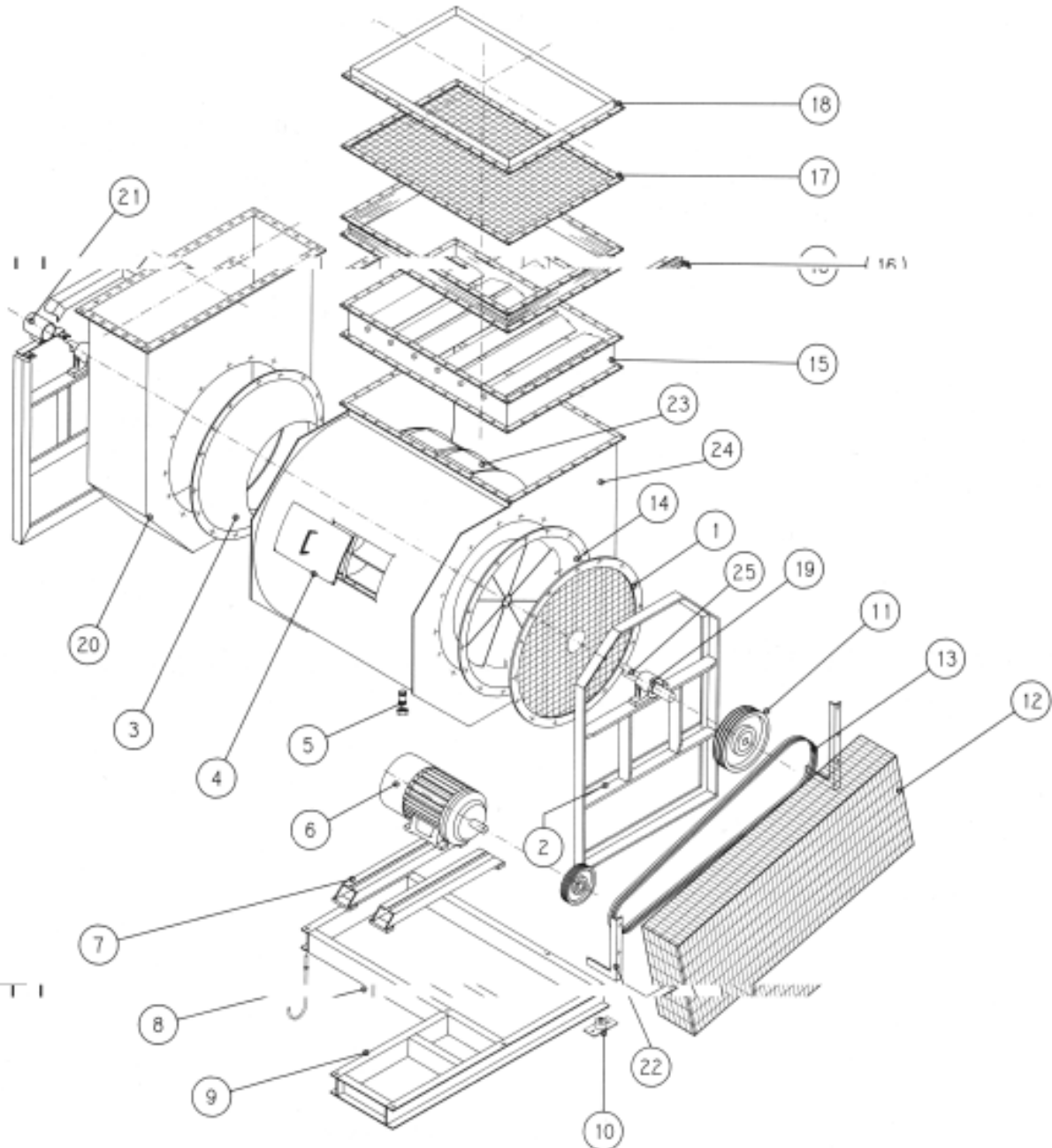

- 1 Inlet flange
- 2 Side frame
- 3 Inlet cone
- 4 Inspection door
- 5 Drain plug
- 6 Motor
- 7 Motor rails
- 8 Foundation bolt
- 9 Common base frame
- 10 Anti-vibration mounts (spring or rubber)
- 11 Pulley
- 12 Belt guard
- 13 Belt

- 14 Inlet vane control
- 15 Damper
- 16 Outlet flexible connection
- 17 Outlet guard
- 18 Outlet flange
- 19 Cast-iron bearing
- 20 Inlet box
- 21 Shaft guard
- 22 Belt guard
- 23 Impeller
- 24 Fan casing
- 25 Shaft

comefri

8. SPARK PROTECTION

Fan operation in areas with combustible gases, vapours or with a possible danger of explosion must adhere to the explosion-proof guidelines (EX-RL9) specified by the Association of Chemical Industries.

According to the likelihood of the occurrence of an explosion, the degree of danger is divided into three different categories, namely: zone 0, 1 and 2:

Zone	Danger of explosion	Possible explosion sources to be avoided
0	Continuously or for a long period of time	Even in case of infrequent operation interference
1	Sometimes	Even in case of operating interferences occurring more frequently
2	Seldom or for a short period of time	during normal operation

Possible explosion sources from a standard fan which must be taken into consideration are as follows:

- a hot surface, due to, for example, the heat generated from bearings
- friction- grinding or impact sparks due to, for example, the contact of the impeller with stationary fan components
- sparks as a result of an electrostatic discharge from non-conducting components (eg. plastic surfaces)

In **Zone 2** there are no special fan explosion precautions. VDE 0165 applies for the motor and control elements.

In **Zone 1** (ignition group G1-G3, with respect to explosion class 1 and 2) fan operation is possible under the following conditions:

1) The combination of the air coming into contact with the fan's construction materials must not be inflammable. To avoid spark formation the following material pairings must be considered:

- a) steel or cast-iron, combined with bronze, brass or copper;
- b) stainless steel combined with stainless steel;

Material pairing with light metal or light metal coatings are not suitable.

2) The bearing's life-span should amount to a minimum of 40 000 hours of operation.

3) The critical fan shaft speed should exceed the operation speed by a minimum of 30%.

4) The fan shaft may only be horizontally installed.

5) The maximum permissible fan speed must be reduced by 20 %.

6) The allowable shaft power for certain pulley diameters must be reduced by 30%.

7) The belt must be an electrostatic conductor and at least 3 belts must be applied.

8) To prevent foreign elements from falling into the fan's inlet, guards should protect the fan according to safety regulations.

In **Zone 0** fan operation is not permitted.

Fans operating in an area threatened by the danger of an explosion are the manufacturer's and user's responsibility to comply to the Ex-RL.

This regulation is justifiable since according to the Ex-RL, the effectiveness of a fan operation must be inspected by experts. This entails both an inspection of the minimum required volume as well as adherence to design demands.

comefri

9. CAST-IRON BEARING

The standard BCZ fans- series are in general, equipped with regreasable plummer block bearings incorporating cast iron housings and ((spherical roller)) bearings. Bearing housing are equipped with ring seals. The bearings are designed for a minimum of 40.000 operating hours at maximum speed and performance. The airflow temperature in standard execution should not be greater than 80° C.

Bearing Type

Fan size	400	450	500	560	630	710	800	900	1000
Bearing Type	SNH 507	SNH 507	SNH 509	SNH 509	SNH 511	SNH 511	SNH 513	SNH 513	SNH 516
	22207	22207	22209	22209	22211	22211	22213	22213	22216

Bearing Type

Fan size		1120	1250	1400	1600	1800	2000
Cl. I	Bearing Type	SNH 513	SNH 513	SNH 516	SNH 518	SNH 520	SNH 522
		22213	22213	22216	22218	22220	22222
Cl. II	Bearing Type	SNH 518	SNH 520	SNH 522	SNH 522	SNH 524	SNH 526
		22218	22220	22222	22222	22224	22226

Regreasing & maintenance

Bearing block type	507	509	511	513	516	518	520	522	524	526
Grease quantity per bearing [g]	8,28	9,77	12.5	18.6	23.3	32	41.4	53	62.3	73.6
Speed [min ⁻¹]	Regreasing interval (in hours)									
250	15000	15000	15000	13000	13000	12000	11000	10000	9000	8000
500	9000	7000	6000	5500	5250	5000	4750	4500	4250	4000
750	5500	5000	4500	4000	3750	3500	3250	3000	2500	2000
1000	4250	3750	3500	3250	3000	2500	2000	1800	1600	1400
1250	3800	3000	2800	2000	1900	1700	1600	1400	1300	900
1500	2300	2000	1800	1500	1400	1300	1200	1000	800	550
1750	2200	1800	1400	1100	1000	900	800	750	550	500
2000	1800	1500	1200	1000	800	700	600	550		
2500	1200	1000	900	750	500	380				
3000	1100	750	600	480	320					
4000	800	450	350							



10. INLET VANE CONTROL

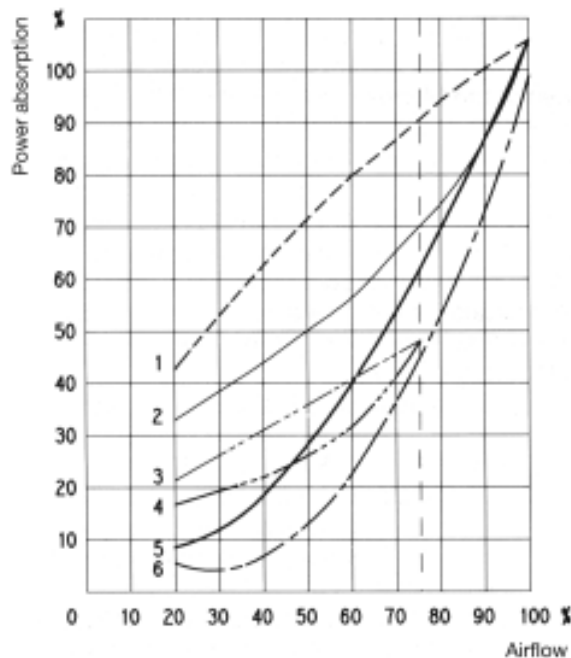

Power absorption with different airflow control systems:

1. Throttle control
2. Inlet vane control
3. Throttle control with multi-speed motor
4. Inlet vane control with multi-speed motor
5. Hydraulic coupling control
6. Inverter driven motor

The efficiency of a control device also depends upon the energy consumption of the selected system. Lower air flow mainly leads to lower energy consumption. The different control systems are distinguished from one another by the level of energy consumption. An important deciding feature, with respect to the choice of a control system, vis-à-vis energy costs, is the air flow quantity.

1) If the air flow variation is for only 85% to 90% of the maximum volume, a simple throttle control, according to the operation duration of the reduced airflow can be a very economical solution.

2) If the air flow variation is for up to 70% of the maximum air flow, the inlet vane control indicates a power absorption very close to the motor speed control.

For an airflow quantity under 60% of maximum airflow, two-speed motors are recommended. In this way, a good similarity to the power absorption of motor speed control can be achieved. Given that the power absorption of a fan is proportional to the speed variation cubed, the performance developments can be monitored in the best way by using a motor speed control.

3) If continuous volume control is required, the fan operating system can be adjusted in order to adapt the fan to the different possible operating conditions by using an inlet vane control type I.V.C. Therefore, the following advantages can be achieved:

- continuous air flow control yielding considerable electrical power savings
- decreased air resistance achieved through normal throttle control
- space savings

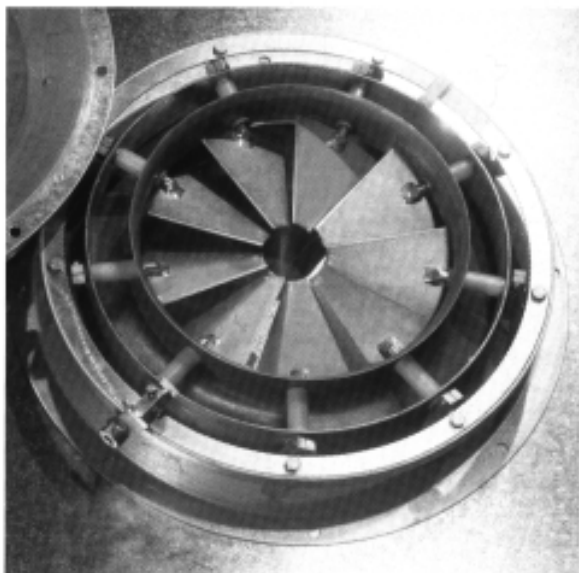
comefri

Airflow regulation by the inlet vane control occurs through the closing or opening of a series of fan blades assembled radially in or before the fan inlet.

The blades can be rotated 90° and a continuous regulation of the airflow can be controlled from an "entirely open" (0°) to an "entirely closed" (90°) position. This allows for performance adjustments to be made.

The operation point where volume and pressure are specified moves along the system resistance curve.

Less air flow results in less absorbed shaft power.

Inlet vane control operation can either be provided in manual or automatic, i.e. through linear or rotating drive, which operates either electrically, hydraulically or pneumatically. Through the installation of an I.V.C. there is a slight increase both in the number of revolutions as well as in the absorbed shaft power in order to achieve nominal performance. I.V.C. Installation also results in a slight increase in the noise level.



11. FAN SELECTION EXAMPLE

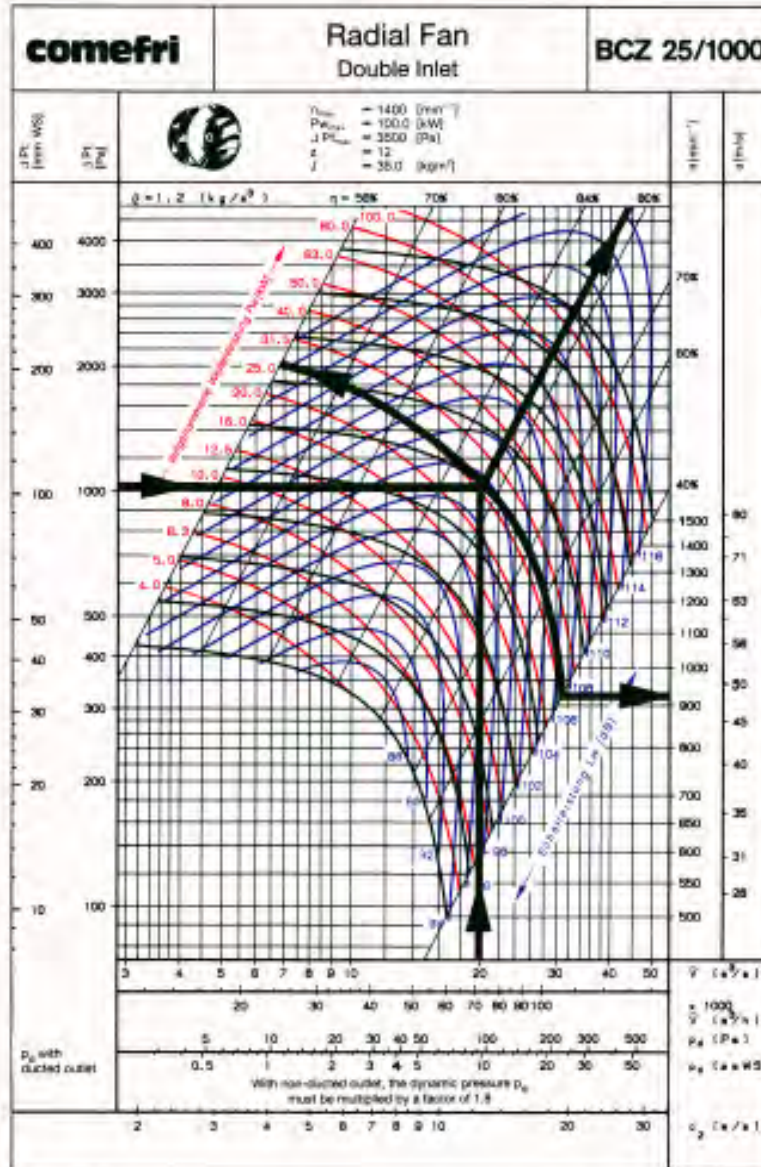

N.B. The above performance diagram of a BCZ 25 indicates the dynamic pressure (p_d) obtained from the fan with ducted outlet. In cases with a "free outlet" the dynamic pressure (p_d) must be determined from the performance diagram using a multiplying factor of 1,8.

Example: BCE 25/1000

Airflow: $V_{nom} = 72.000 \text{ m}^3/\text{h} - V_{nom} = 20 \text{ m}^3/\text{sec}$

Total pressure: $\Delta p_t = 1000 \text{ Pa}$

From the performance diagram, the following can be determined:

Fan speed: $n = 910 \text{ min}^{-1}$

Absorbed shaft power: $P_W = 24,7 \text{ kW}$

Totale efficiency: $\eta = 81\%$

Outlet speed: $c_2 = 12,3 \text{ m/s}$

Dynamic pressure (ducted outlet) $p_d = 100 \text{ Pa}$

Dynamic pressure (free outlet) $p_{d, free} = p_{d, ducted} \times 1,8 = 180 \text{ Pa}$

comefri

12. TEMPERATURE CORRECTION FACTORS

The performance diagrams refer to airflow with an air density of $\rho = 1,2 \text{ kg/m}^3$ and at 20°C as well as 760 mm Hg barometric pressure.

Therefore, in different operating conditions the required performance data must be corrected by multiplying by a correction factor of "k" before selecting a fan from the performance diagram.

One can obtain the actual absorbed shaft power by dividing the diagram data by a factor of "k"

Correction factor "K"

meters above sea level	Special execution													
	Temperature [$^\circ\text{C}$]													
	-40	-20	0	+20	+40	+60	+80	+100	+150	+200	+250	+300	+350	+400
0	0,79	0,86	0,93	1,00	1,07	1,14	1,20	1,27	1,44	1,61	1,78	1,95	2,13	2,30
250	0,81	0,88	0,95	1,02	1,09	1,16	1,23	1,30	1,48	1,65	1,83	2,00	2,18	2,35
500	0,83	0,91	0,98	1,05	1,12	1,19	1,27	1,34	1,52	1,70	1,58	2,05	2,23	2,41
750	0,85	0,93	1,00	1,08	1,15	1,22	1,30	1,37	1,56	1,74	1,92	2,11	2,30	2,46
1.000	0,88	0,95	1,03	1,11	1,18	1,26	1,33	1,41	1,60	1,79	1,98	2,17	2,35	2,54
1.500	0,93	1,01	1,09	1,17	1,25	1,33	1,41	1,49	1,69	1,89	2,09	2,29	2,49	2,69
2.000	0,99	1,07	1,16	1,24	1,32	1,41	1,49	1,58	1,79	2,00	2,21	2,42	2,64	2,85

Example:

At 100°C and 500 m above sea level (locate the adjustment factor of $k=1,34$ from the above table) using the results in the preceding fan selection example on page 14, the following changed performance data would be obtained:

Airflow: $V_{nom} = 72.000 \text{ m}^3/\text{h} - V_{nom} = 20 \text{ m}^3/\text{sec}$

Total pressure: $\Delta p_{t1} = \Delta p_t : K = 746 \text{ Pa}$

Fan speed: $n_1 = n = 910 \text{ min}^{-1}$

Absorbed shaft power: $P_{W1} = P_W : K = 18,43 \text{ kW}$

Totale efficiency: $\eta_1 = \eta = 81\%$

Outlet speed: $c_{21} = c_2 = 12,3 \text{ m/s}$

Dynamic pressure (ducted outlet) $p_{d1} = p_d : K = 75 \text{ Pa}$

Dynamic pressure (free outlet) $P_{d \text{ free}} = P_{d \text{ ducted}} \times 1,8 = 135 \text{ Pa}$

comefri

13. SOUND DATA

Sound Power

The total sound power level L_w referred to by 1×10^{-12} watts, necessary for the calculation and interpretation of sound reduction components, is indicated in the fan diagram as a parameter recorded in dB. To obtain the sound power level at a particular middle octave frequency, one must reduce the total sound power level L_w by the correction factor L_{wo} found in the following table. The values indicated on the performance diagrams refer to the sound power measured in either the fan inlet or outlet.

Octave frequency	Hz	63	125	250	500	1k	2k	4k	8k
ΔL_{wo}	dB	2	8	9	15	17	19	23	25

The weighted total sound power level L_{wa} dB(A) values, can be obtained by deducting 10 dB from the total sound power level L_w .

Sound Pressure

In general, sound pressure is of interest to the user more so than sound power, since sound pressure is measurable. For fans installed on industrial grounds with free or ducted inlet or outlet, the sound pressure L_p measured in dB with 2×10^{-5} Pa, can be approximated as follows. The sound pressure L_p must also be reduced by the correction factors ΔL_{pe} indicated in the following tables.

In an open area:

From a distance of	1,5 m	3 m	10 m	20 m	50 m
ΔL_{pe}	12	18	28	34	42

In a plant:

From a distance of	1,5 m	3 m	10 m	20 m	50 m
ΔL_{ps}	12	15	24	27	32

Example: Fan type BCZ 25/1000, airflow 20 m³/s, total pressure 1450 Pa, speed 1070 min⁻¹.

Octave band	Hz	63	125	250	500	1 k	2 k	4 k	8 k	Scale A
L_w	dB	100	100	100	100	100	100	100	100	100
ΔL_{wo}	dB	2	8	9	15	17	19	23	25	10

Resulting in the octave range:

$L_{wo} = L_w - \Delta L_{wo}$	dB	98	92	91	85	83	81	77	75	90
--------------------------------	----	----	----	----	----	----	----	----	----	----

The weighted sound pressure L_{po} measured from a distance of 3 m in a plant can be approximated as follows:

Octave band	Hz	63	125	250	500	1 k	2 k	4 k	8 k	Scale A
L_{wo}	dB	98	92	91	85	83	81	77	75	90
ΔL_{ps} (from 3 m)	dB	15	15	15	15	15	15	15	15	15
$L_{po} = L_{wo} - \Delta L_{ps}$	dB	83	77	76	70	68	66	62	60	75

Essentially, it is necessary to consider that precise results for sound level and frequency can be obtained only after the installation and operation start-up of the fan at the mounting location. Moreover, additional factors must be taken into consideration, such as, other mechanical equipment and construction factors in the proximity of the fan which may notably increase or decrease the sound level.

comefri

14. TRANSMISSION LOSSES

The absorbed fan power at the shaft shown in the performance diagram does not take transmission losses into consideration. Therefore, the transmission losses indicated in the diagram below must be added (in accordance with AMCA).

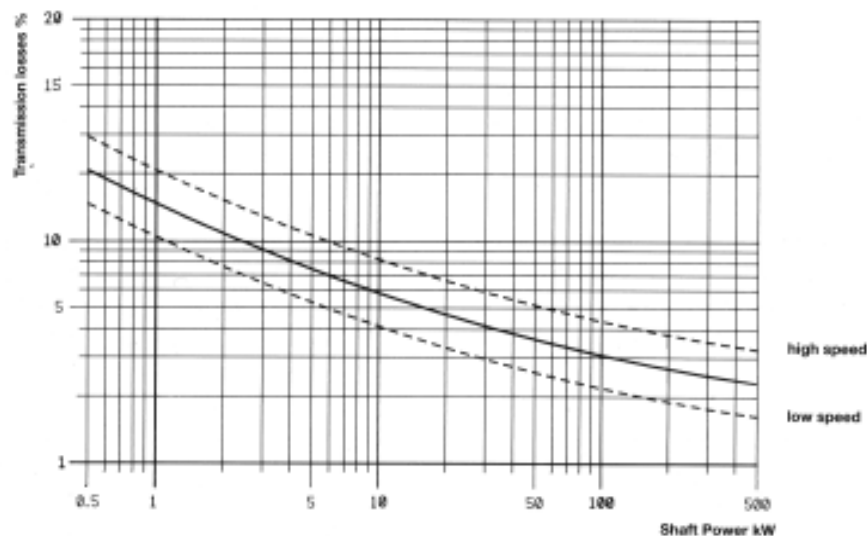

Example: transmission losses according to the above diagram are between 4% and 8% corresponding to the fan speed.

15. ORDER EXAMPLE

A Comefri industrial fan order must be specified as follows:

BCZ 25/1400 - CI 2 - LG 90° - Sist. 11D

Section by section, this translates into:

BCZ: Radial, backward curved blades, double inlet
 25: Series specification
 1400: Size, specifying the outside impeller diameter
 CI 2: Construction execution, class 2
 LG 90°: Discharge position
 Sist. 11D: Arrangement specification

It is necessary to specify additional order information separately, such as accessories and their respective positions.

comefri

16. TEST LABORATORY

Fan performance data indicated on the diagrams have been determined by the company's own test laboratory which adheres to internationally established guidelines DIN 24163, BSI 848 and AMCA.

Operating conditions that were used to determine the fan characteristic curves are:

ρ air flow = 1,2 kg/m³ at 1013 mbar and 20°C.

For the performance data, the tolerances for class 2 must be taken into consideration.

Upon request, class 1 can be provided.

The performance data is valid for an uninterrupted flow in ducting adjacent to the fan, i.e. straight duct connections.

With irregular flows adjacent to the fan away, significant differences may appear in the performance data.

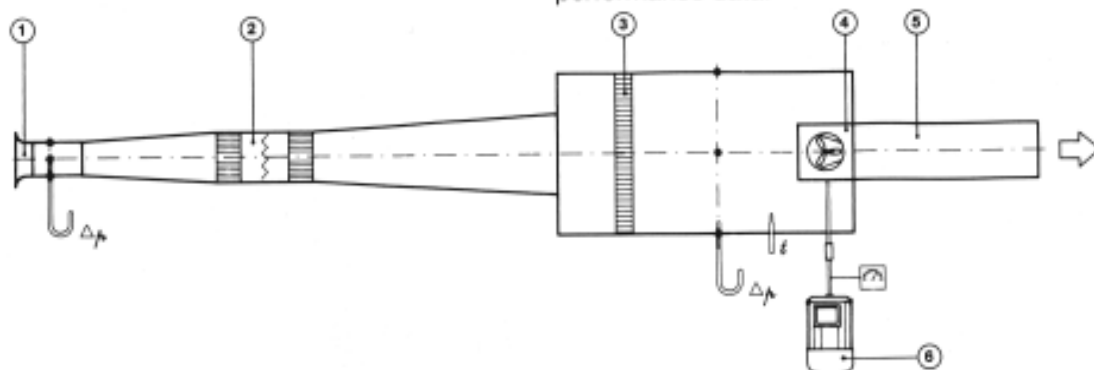

1. Normalized inlet
2. Adjustable damper
3. Rectifier
4. Fan
5. Duct
6. Motor

N.B. Dynamic pressure P_d of the BCZ 25 series indicated on the performance diagram refers to a "ducted fan". The "free", non-ducted fan value is obtained as follows:

$$P_{d \text{ free}} = P_{d \text{ ducted}} \times 1,8$$

The "absorbed shaft power" indicated on the performance diagram does not account for transmission losses which must be added for each diagram (see page 15).

comefri

17. BCZ 25 DOUBLE INLET INDUSTRIAL RADIAL FAN

- DISCHARGE POSITION
- DIMENSIONS

comefri

Discharge Position
BCZ 25/400 ÷ 1000

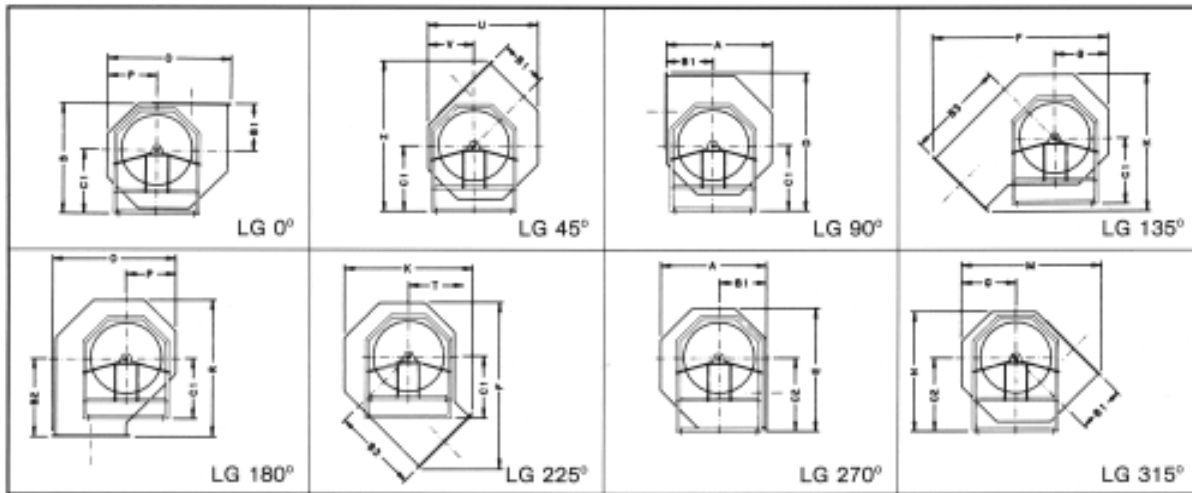

	400	450	500	560	630	710	800	900	1000
A	628	694	769	858	963	1084	1220	1370	1521
B1	283	308	342	381	428	483	543	610	678
B2	440	482	523	582	645	804	803	926	1001
B3	664	723	776	873	910	1092	1198	1346	1421
C1	344	386	427	477	535	602	677	760	843
C2	460	512	560	620	666	790	880	980	1080
D	782	873	964	1074	1202	1367	1533	1715	1898
E	752	838	921	1023	1142	1298	1452	1622	1792
F	878	1212	1323	1471	1608	1868	2077	1327	2528
G	318	356	394	440	493	554	624	700	777
K	878	965	1049	1172	1263	1479	1637	1029	1978
M	828	918	1016	1131	1267	1437	1613	1807	2002
N	733	817	897	996	1112	1264	1413	1579	1744
O	731	814	899	1000	1119	1274	1428	1597	1766
P	292	326	356	403	452	508	572	642	712
R	784	867	950	1064	1180	1409	1480	1686	1844
S	628	694	769	853	963	1084	1220	1370	1521
T	500	543	577	649	676	818	894	999	1053
U	650	727	805	899	1009	1134	1276	1433	1589
V	273	305	337	376	422	474	533	599	664
Z	854	948	1048	1168	1309	1485	1666	1867	2088

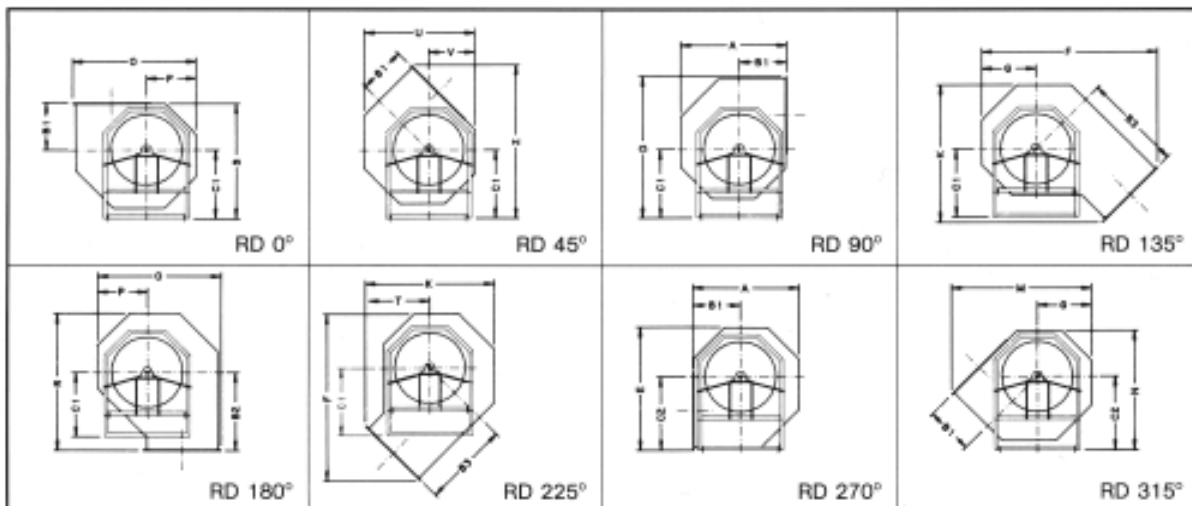

For BCZ 25/400 ÷ 1000 dimensions see page 19

comefri

Dimensions BCZ 25/400 ÷ 1000

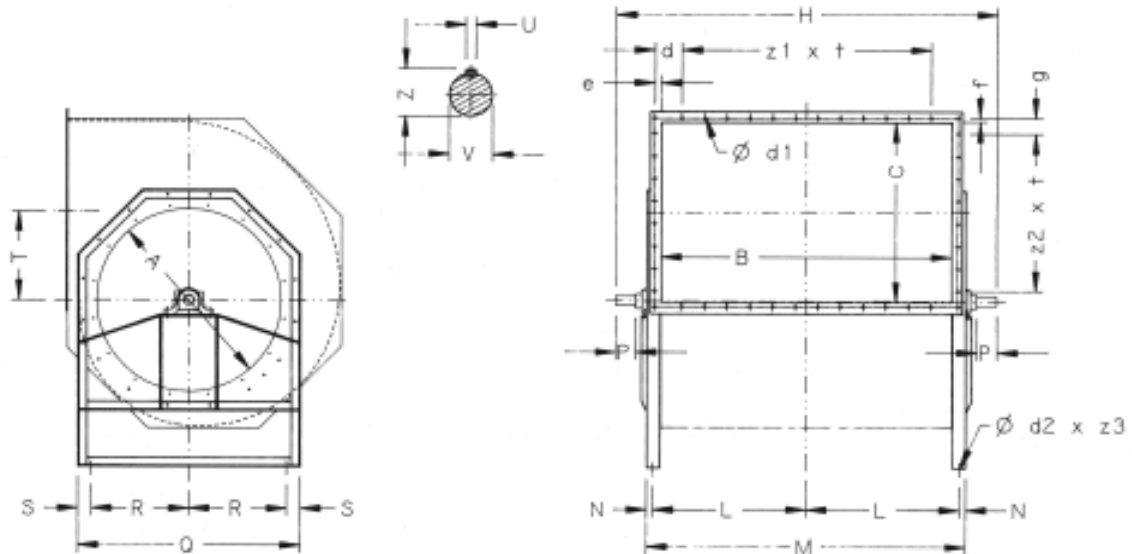

	400	450	500	560	630	710	800	900	1000
A	430	470	520	600	650	730	820	920	1020
B	632	712	802	902	1002	1143	1288	1458	1656
C	402	452	502	562	632	712	802	902	1002
L	344	394	439	500	547	618	705	790	889
M	718	818	908	1030	1130	1271	1446	1616	1814
N	15	15	15	15	18	18	18	18	18
Q	538	596	660	694	780	870	994	1110	1220
R	229	258	290	307	350	395	457	515	570
S	40	40	40	40	40	40	40	40	40
T	197	222	247	276	311	350	395	444	494
H	950	1030	1173	1275	1425	1596	1788	1985	2236
P	60	60	80	80	80	110	110	110	140
U	8	8	10	10	14	14	16	16	16
V	28	28	38	38	48	48	55	55	65
Z	30	30	40.5	40.5	50.5	50.5	58	58	68
d	150	65	110	160	85	169	116	76	175
e	22	22	22	22	22	35	35	35	35
z1	3	5	5	5	7	7	9	11	11
f	22	22	22	22	22	35	35	35	35
g	160	60	85	115	150	78	123	173	98
z2	1	3	3	3	3	5	5	5	7
t	125	125	125	125	125	125	125	125	125
d1	12	12	12	12	12	12	12	12	12
d2	12	12	12	12	15	15	15	15	15
z3	6	6	6	6	6	6	6	6	6

For BCZ 25/400 ÷ 1000 Discharge Position see page 18

comefri

Discharge Position BCZ 25/1120 ÷ 2000

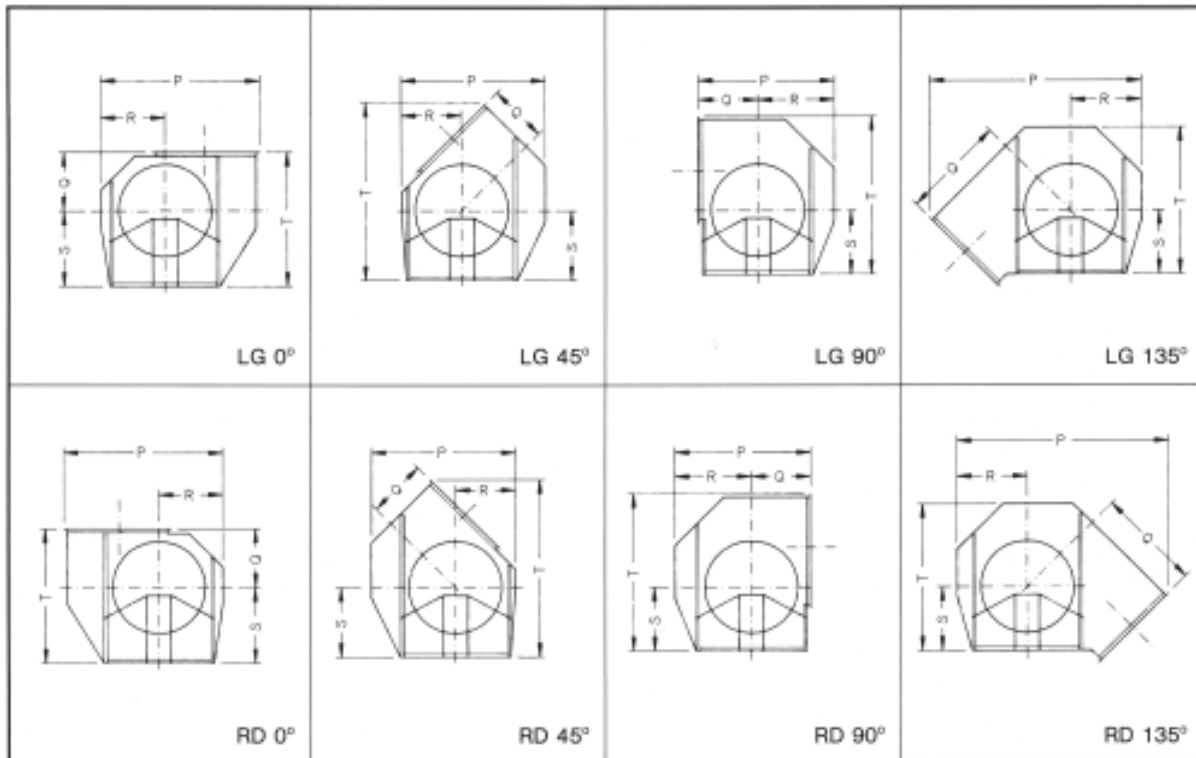

		1120	1250	1400	1600	1800	2000
LG/RD 0°	P	1917	2139	2396	2738	3081	3423
	Q	728	813	910	1040	1170	1300
	R	789	880	986	1127	1268	1409
	S	939	1048	1174	1342	1509	1677
	T	1667	1861	2084	2382	2679	2977
LG/RD 45°	P	1770	1976	2213	2529	2845	3161
	Q	728	813	910	1040	1170	1300
	R	739	825	924	1056	1188	1320
	S	866	967	1083	1238	1392	1547
	T	2169	2421	2711	3098	3486	3873
LG/RD 90°	P	1667	1861	2084	2382	2679	2977
	Q	728	813	910	1040	1170	1300
	R	939	1048	1174	1342	1509	1677
	S	789	880	986	1127	1268	1409
	T	1912	2134	2390	2731	3073	3414
LG/RD 135°	P	2571	2870	3214	3673	4132	4591
	Q	1288	1438	1610	1840	2070	2300
	R	866	967	1083	1238	1392	1547
	S	789	880	986	1127	1268	1409
	T	1820	2031	2275	2600	2925	3250

For BCZ 25/1120 ÷ 2000 dimensions see page 22

comefri

Discharge Position BCZ 25/1120 ÷ 2000

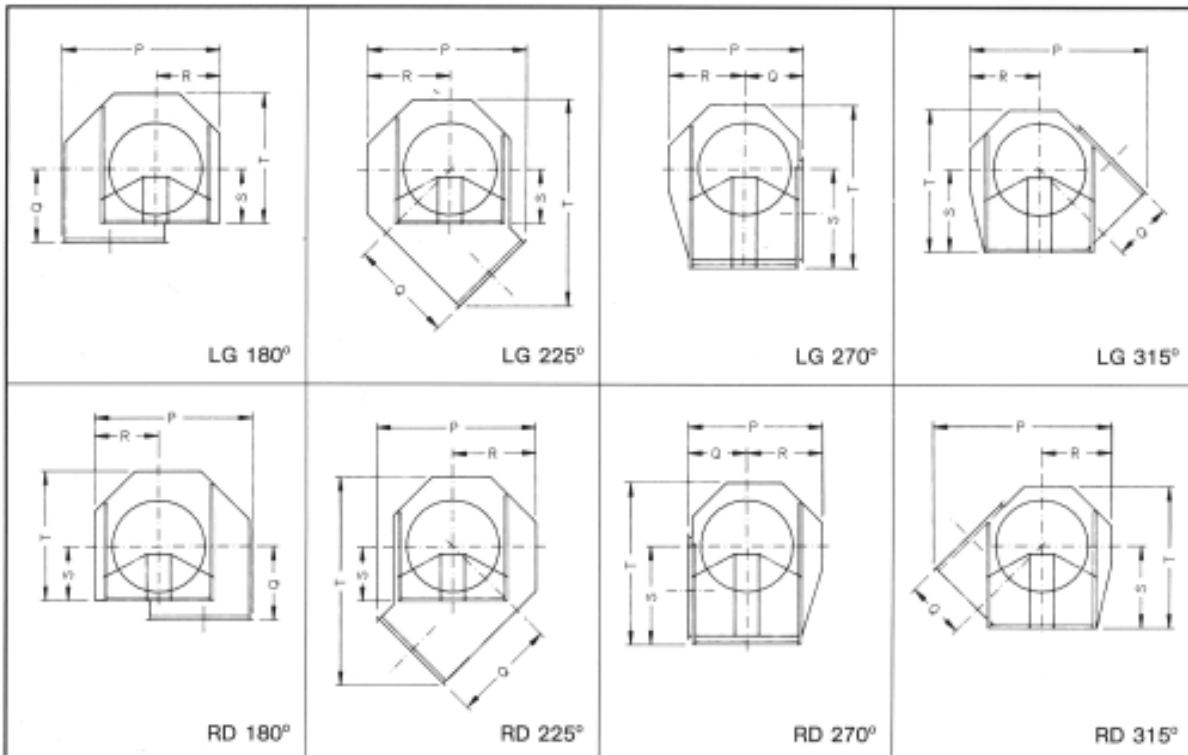

		1120	1250	1400	1600	1800	2000
LG/RD 180°	P	1912	2134	2390	2731	3073	3414
	Q	798	877	988	1109	1270	1391
	R	789	880	986	1127	1268	1409
	S	678	757	848	969	1090	1211
	T	1618	1805	2022	2311	2600	2889
LG/RD 225°	P	1770	1976	2213	2529	2845	3161
	Q	1288	1438	1610	1840	2070	2300
	R	739	825	924	1056	1188	1320
	S	678	757	848	969	1090	1211
	T	2566	2864	3208	3666	4125	4583
LG/RD 270°	P	1667	1861	2084	2382	2679	2977
	Q	728	813	910	1040	1170	1300
	R	939	1048	1174	1342	1509	1677
	S	1114	1243	1392	1591	1790	1989
	T	1902	2123	2378	2718	3057	3397
LG/RD 315°	P	2169	2421	2711	3098	3486	3873
	Q	728	813	910	1040	1170	1300
	R	866	967	1083	1238	1392	1547
	S	1031	1151	1289	1473	1657	1841
	T	1770	1976	2213	2529	2845	3161

For BCZ 25/1120 ÷ 2000 dimensions see page 22

comefri

Dimensions BCZ 25/1120 ÷ 2000

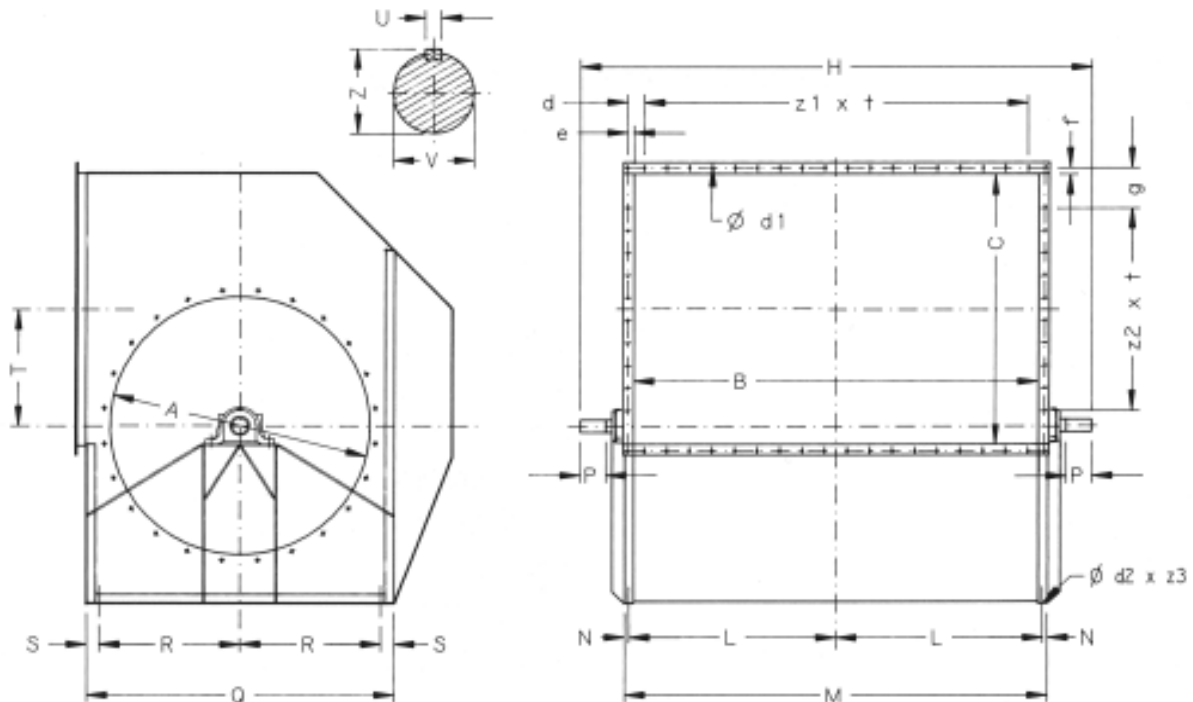

	1120	1250	1400	1600	1800	2000	
A	1122	1252	1402	1602	1802	2002	
B	1858	2080	2320	2582	2921	3301	
C	1122	1252	1402	1602	1802	2002	
L	959	1070	1190	1326	1495	1685	
M	1958	2180	2420	2702	3041	3421	
N	20	20	20	25	25	25	
Q	1360	1520	1700	1950	2200	2450	
R	631	710	800	925	1050	1175	
S	50	50	50	50	50	50	
T	557	621	696	795	895	994	
CLASSE II	H	2438	2690	3015	3277	3626	4011
	P	140	140	170	170	170	170
	U	20	20	22	22	25	25
	V	70	70	80	80	90	90
	Z	74.5	74.5	85	85	95	95
CLASSE I	H	2328	2550	2880	3172	3601	3996
	P	110	110	140	140	170	170
	U	16	16	18	20	22	25
	V	55	55	65	75	80	90
	Z	59	59	69	79.5	85	95
d	151	137	132	153	193	133	
e	35	35	35	45	45	45	
z1	13	15	17	19	21	25	
f	35	35	35	45	45	45	
g	158	98	173	158	133	108	
z2	7	9	9	11	13	15	
t	125	125	125	125	125	125	
d1	12	12	12	15	15	15	
d2	15	15	15	20	20	20	
z3	6	6	6	6	6	6	

For BCZ 25/1120 ÷ 2000 Discharge Position see page 20 and 21

comefri

18. PERFORMANCE CURVES

Size	Page
● BCZ 25/400	24
● BCZ 25/450	25
● BCZ 25/500	26
● BCZ 25/560	27
● BCZ 25/630	28
● BCZ 25/710	29
● BCZ 25/800	30
● BCZ 25/900	31
● BCZ 25/1000	32
● BCZ 25/1120	33
● BCZ 25/1250	34
● BCZ 25/1400	35
● BCZ 25/1600	36
● BCZ 25/1800	37
● BCZ 25/2000	38

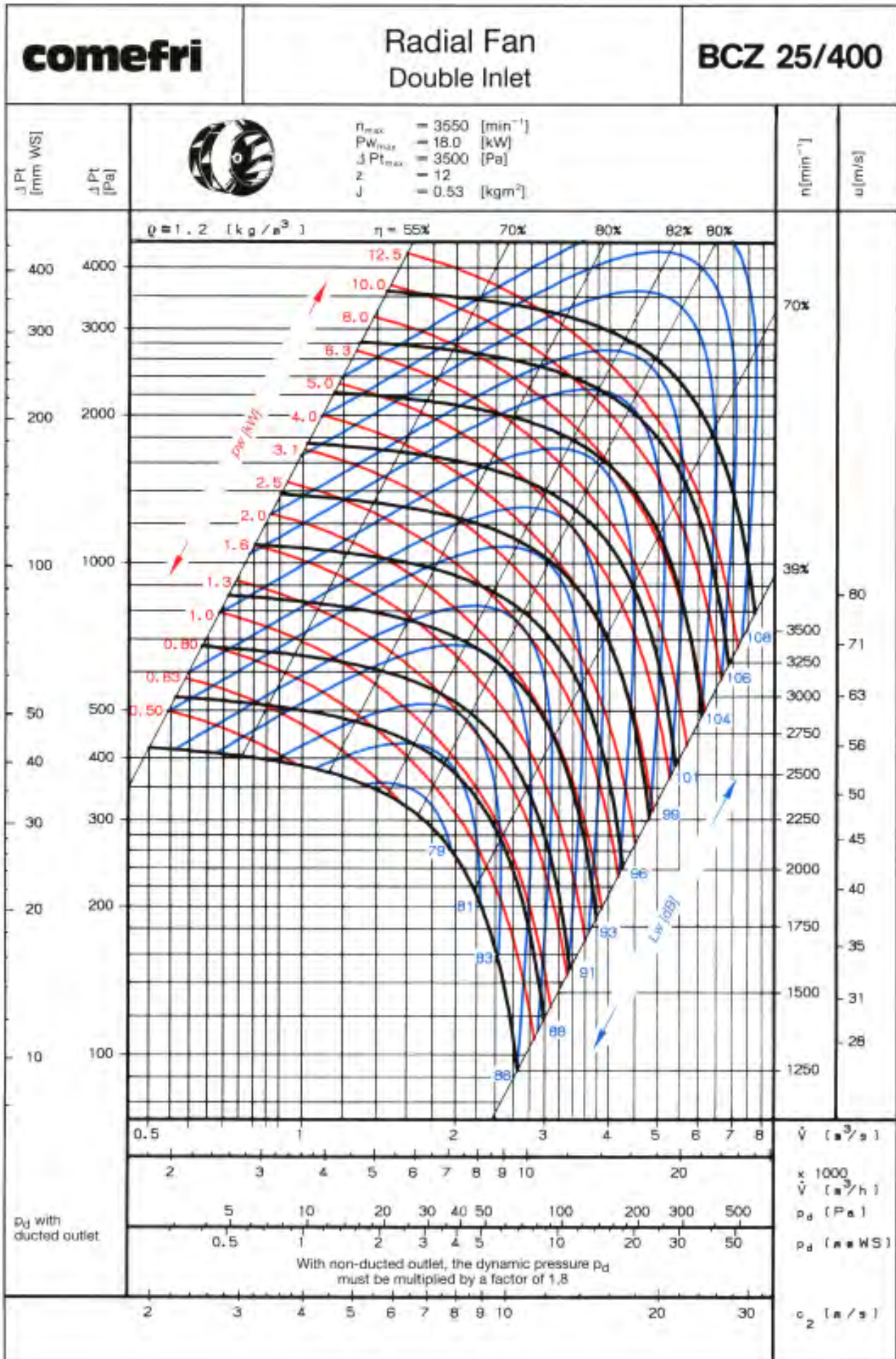

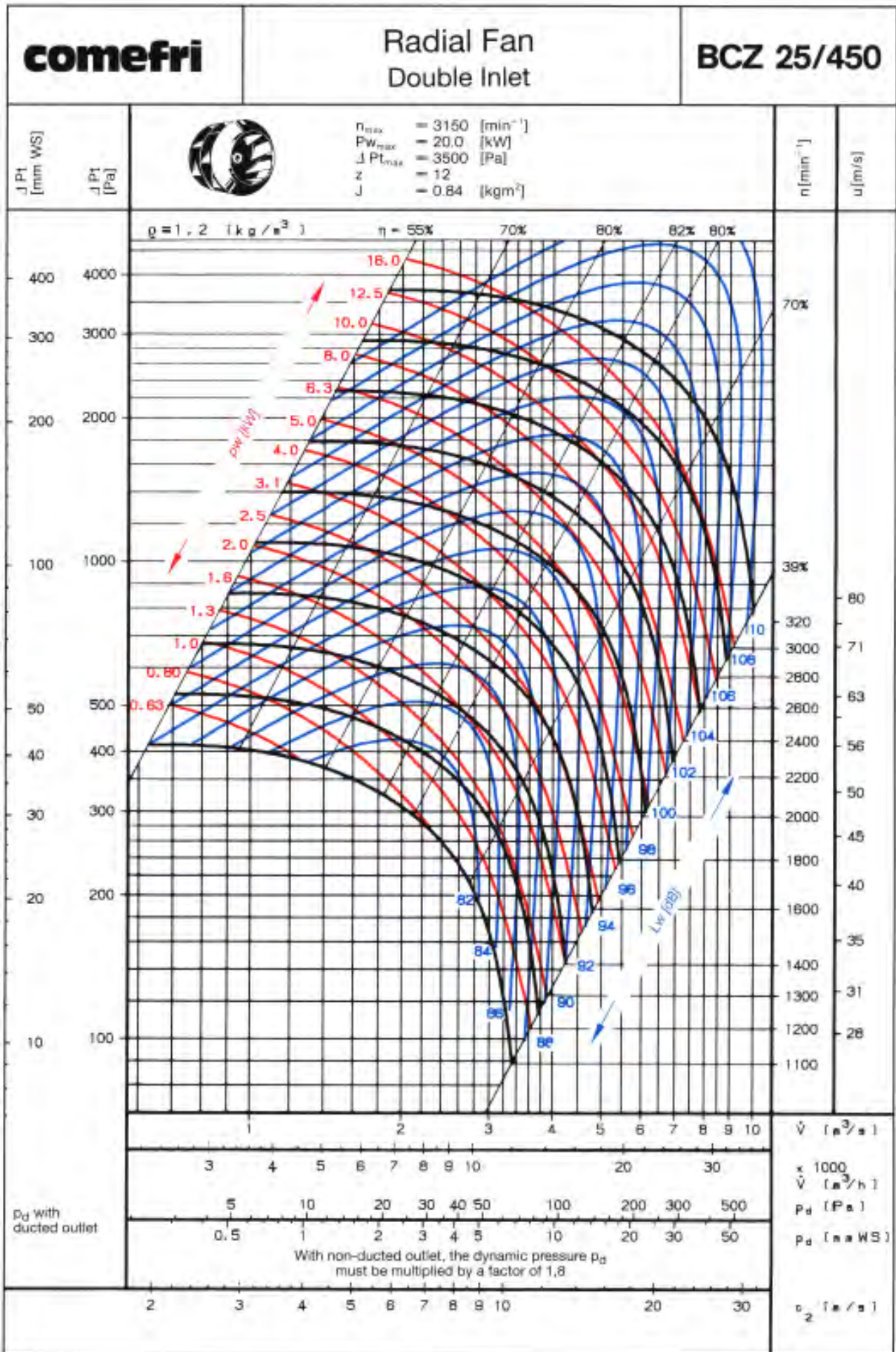

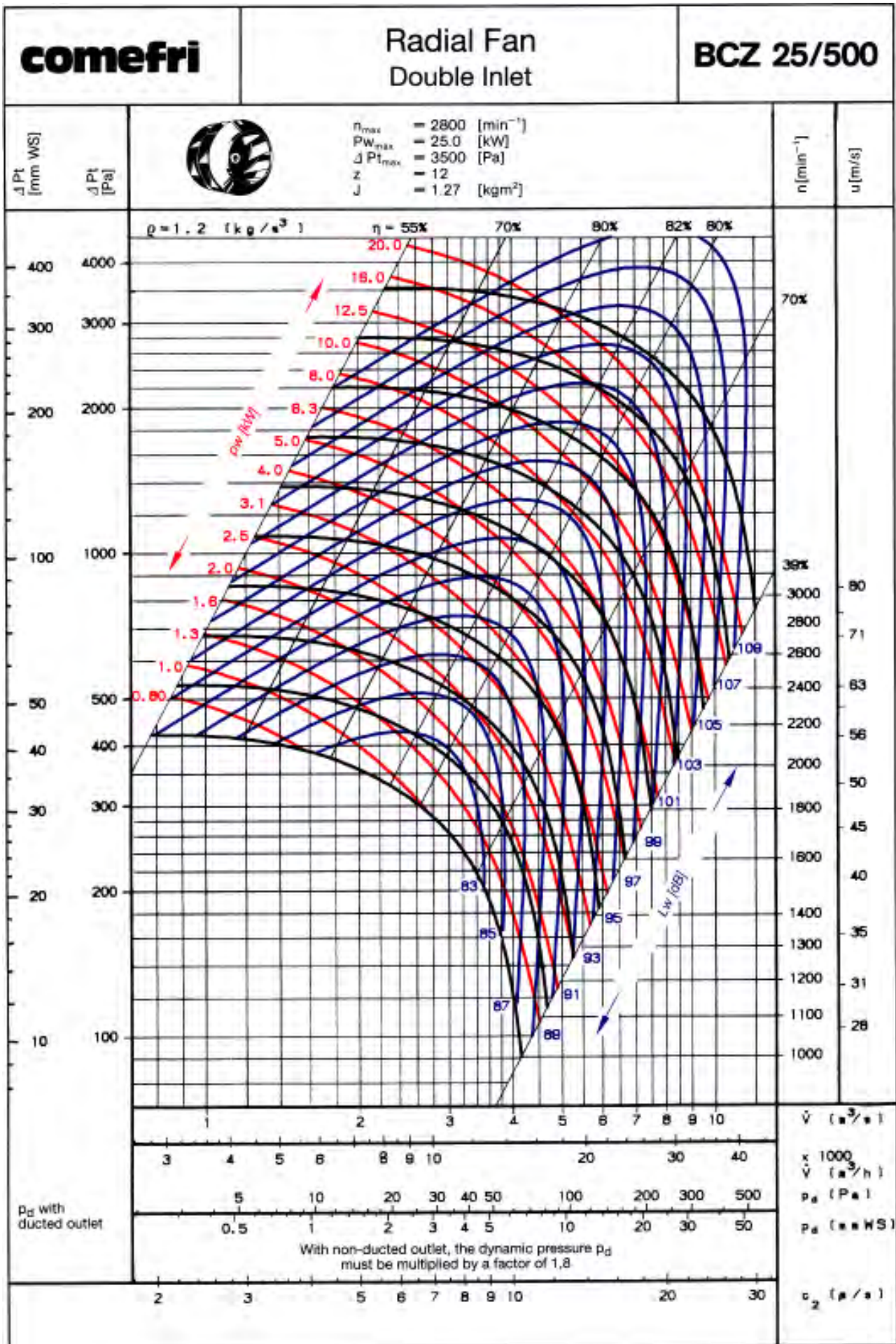

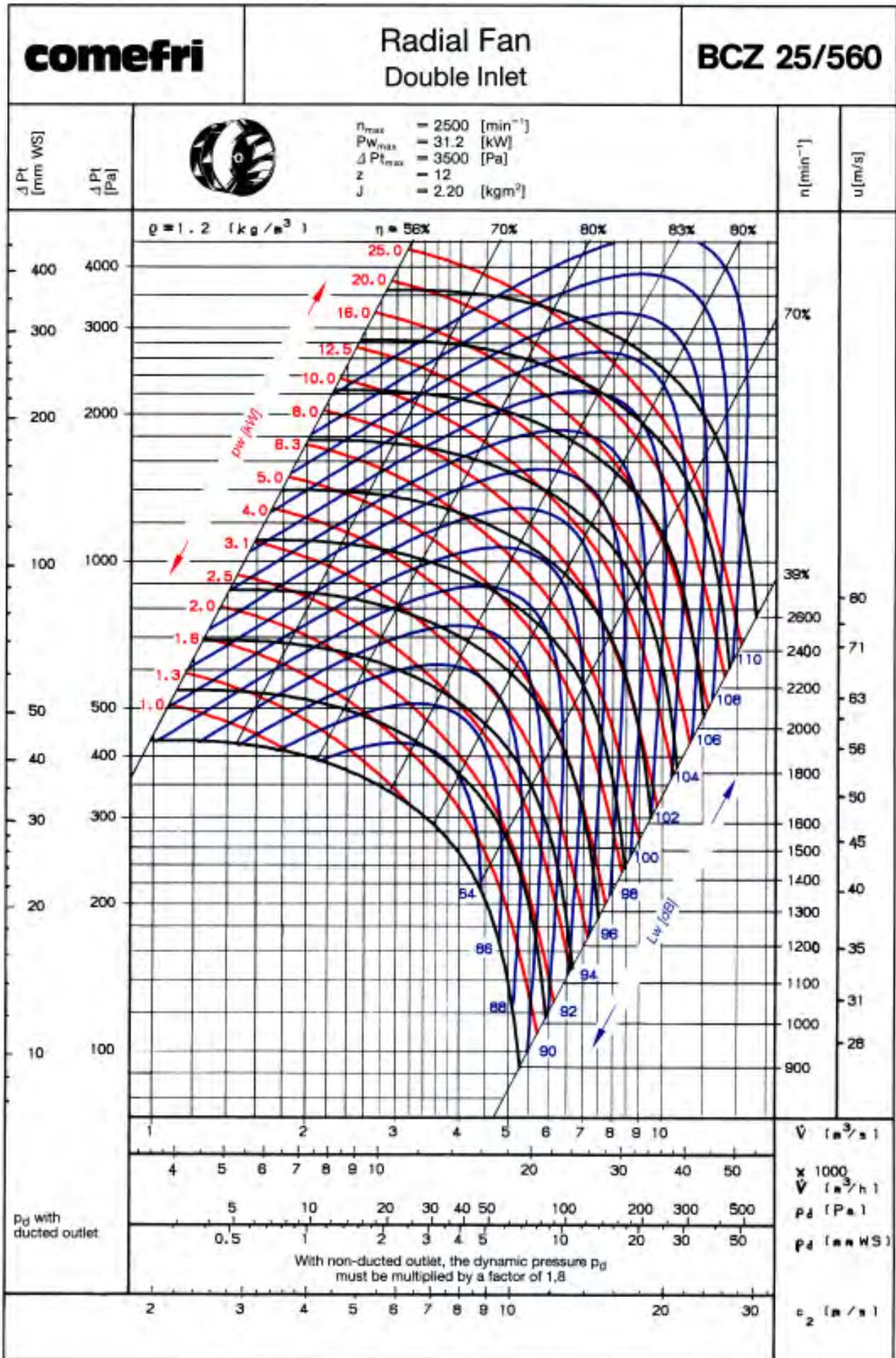

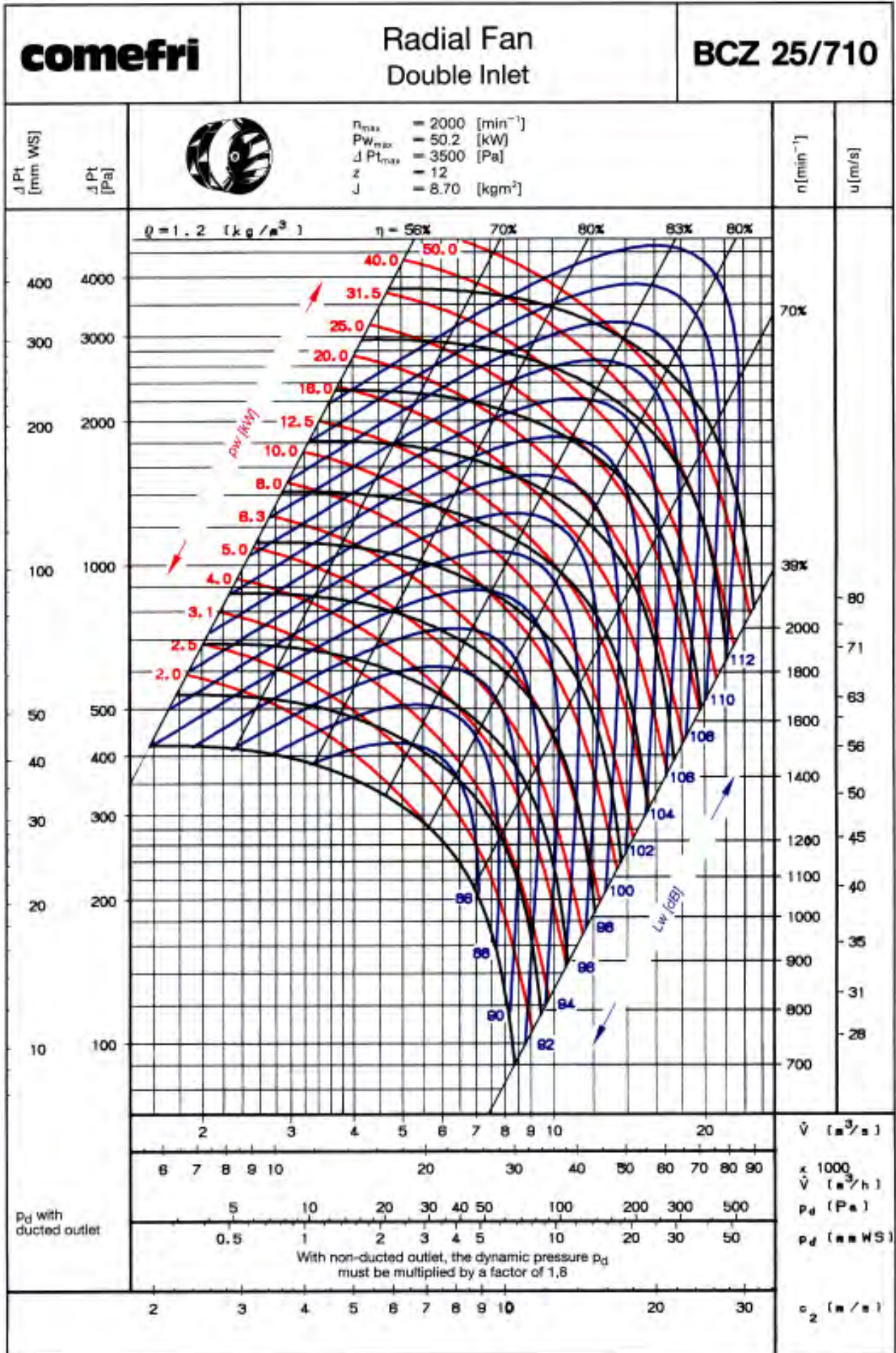

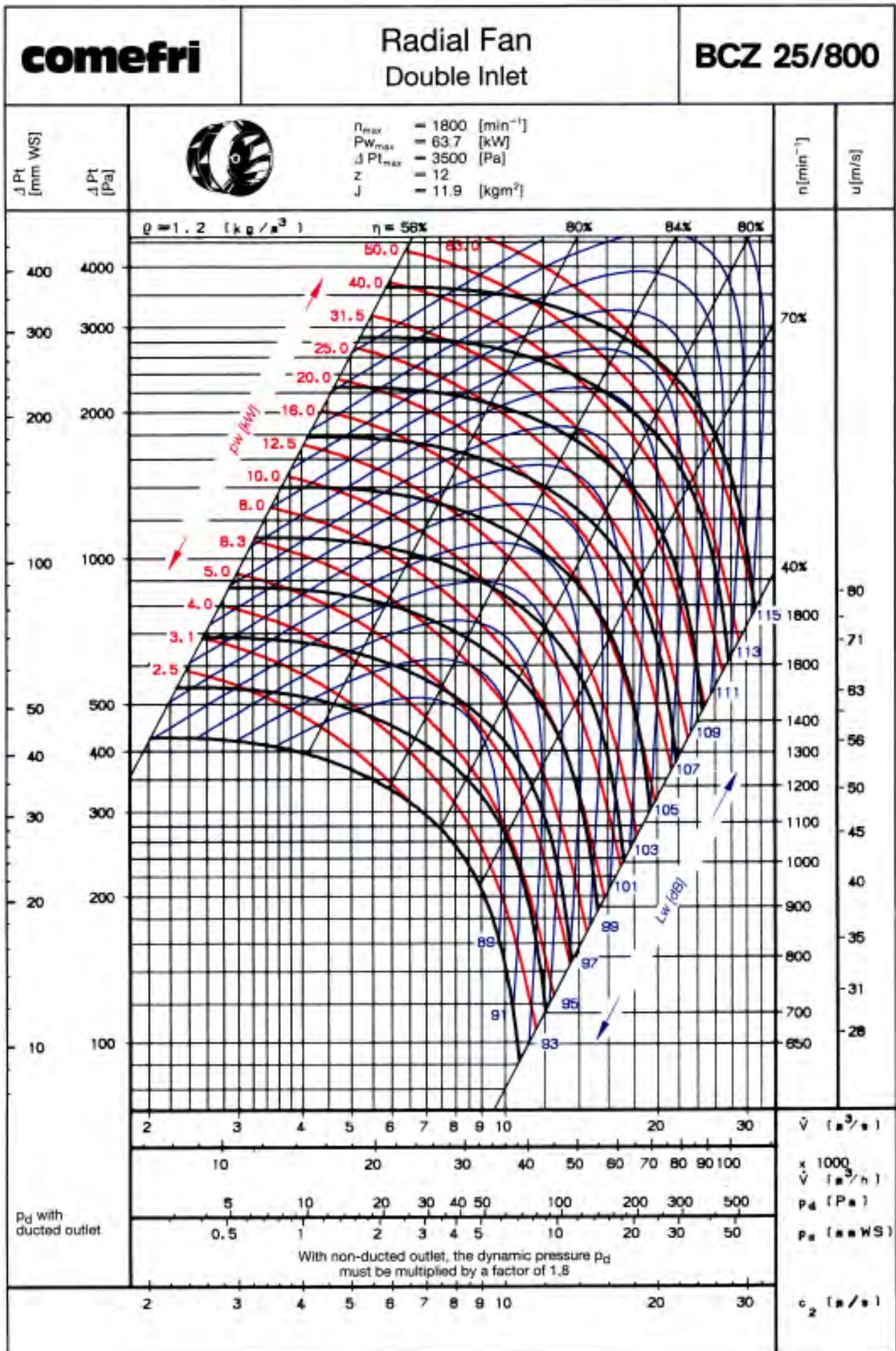

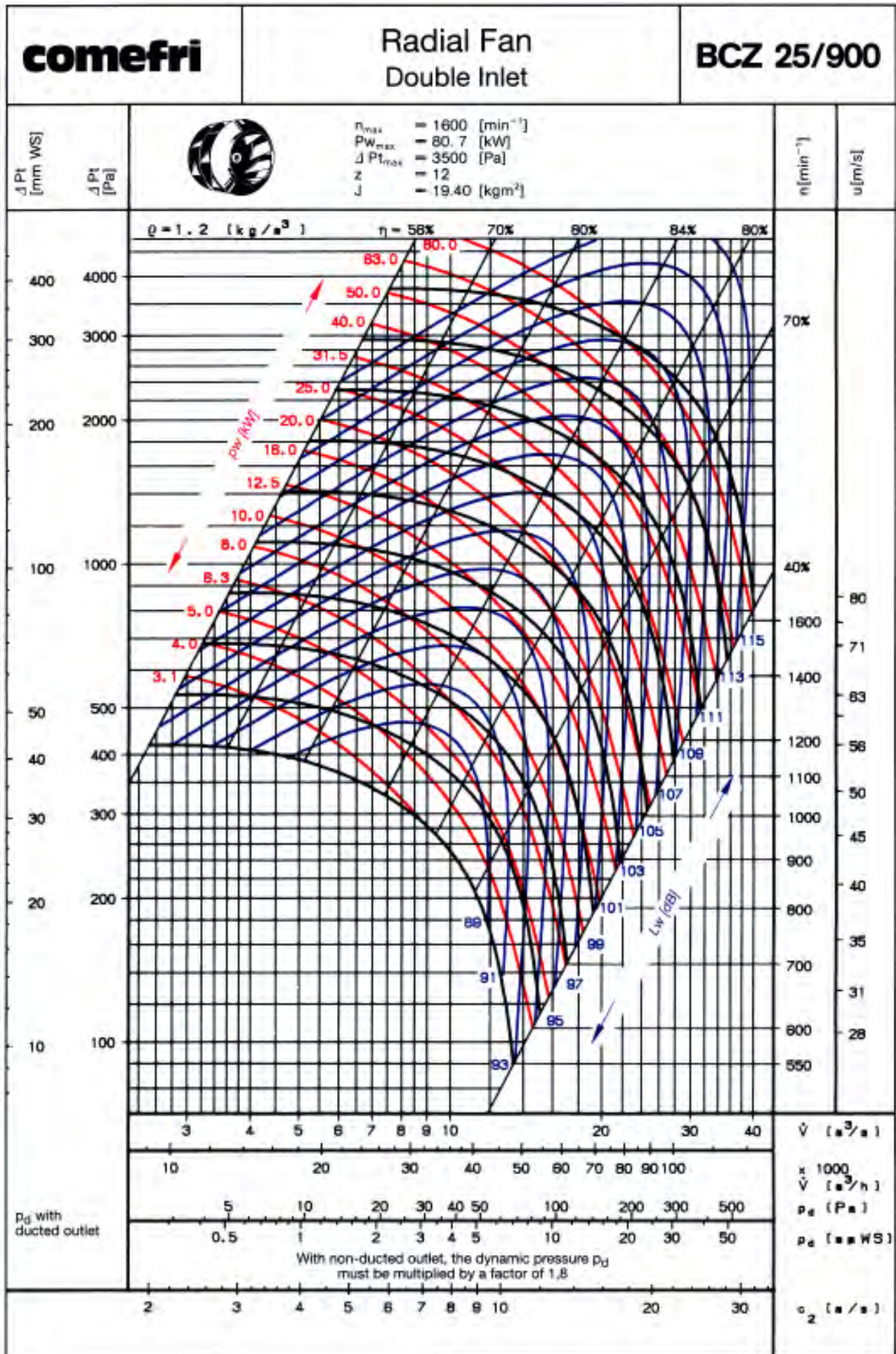

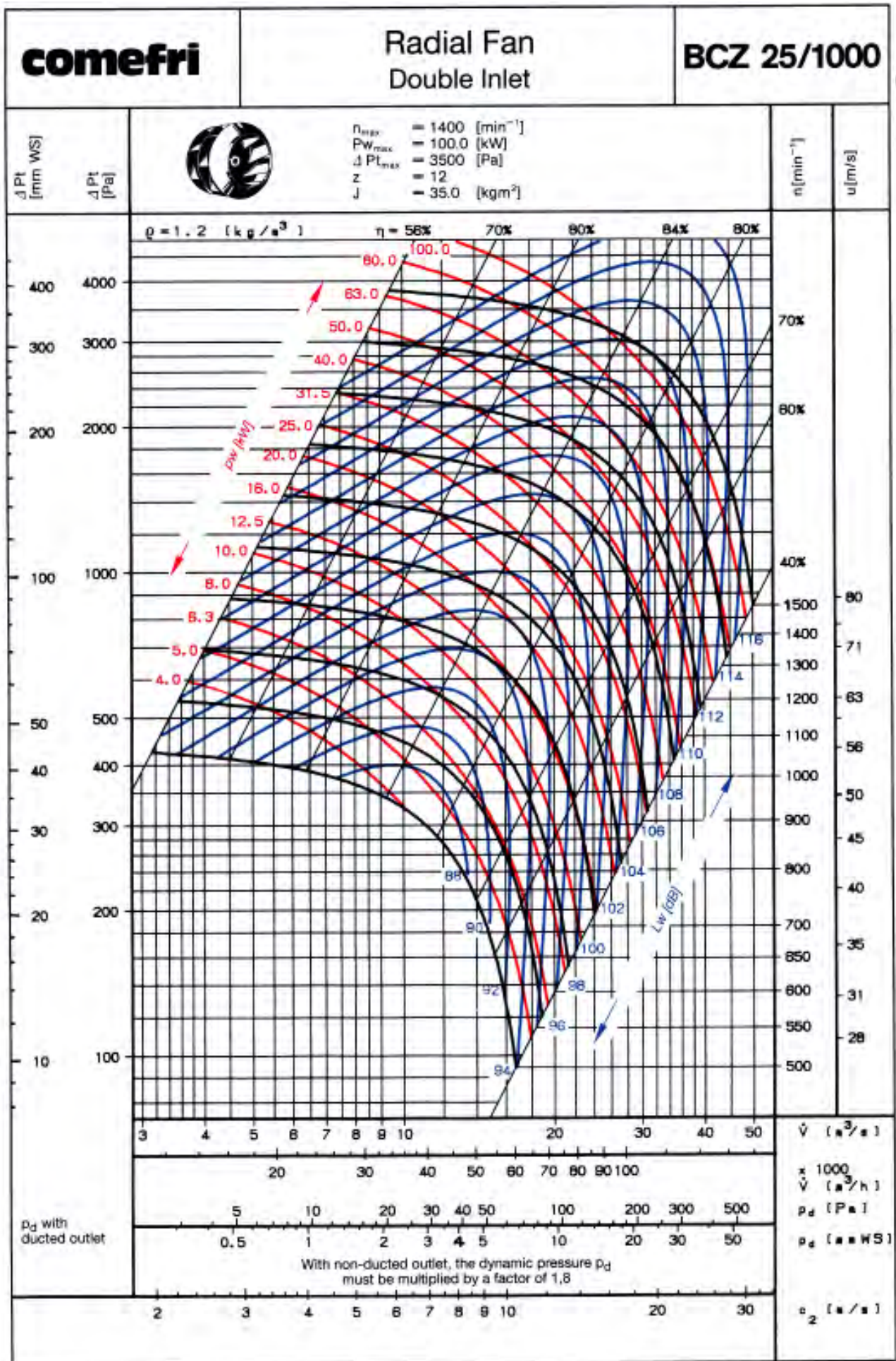

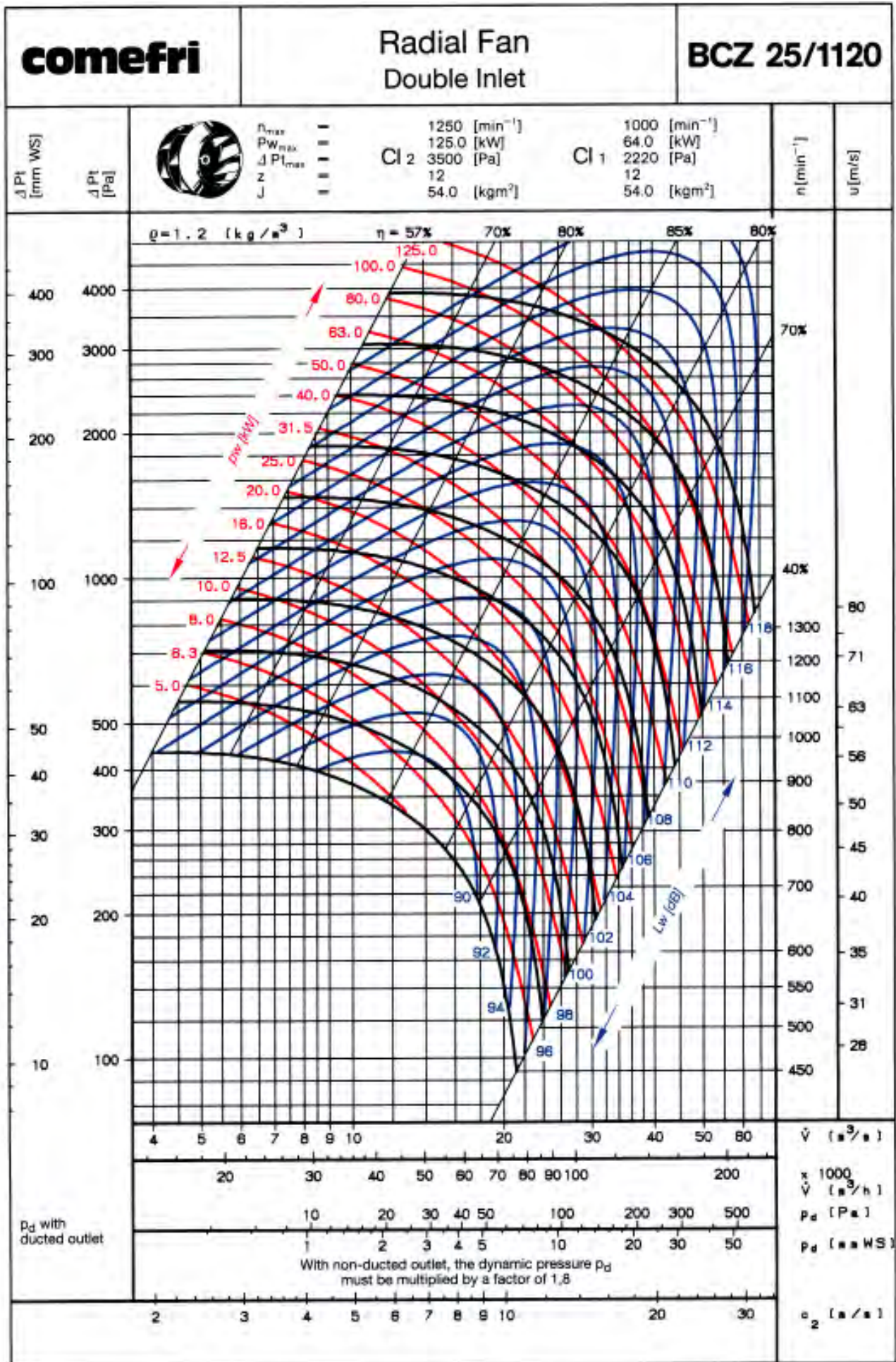

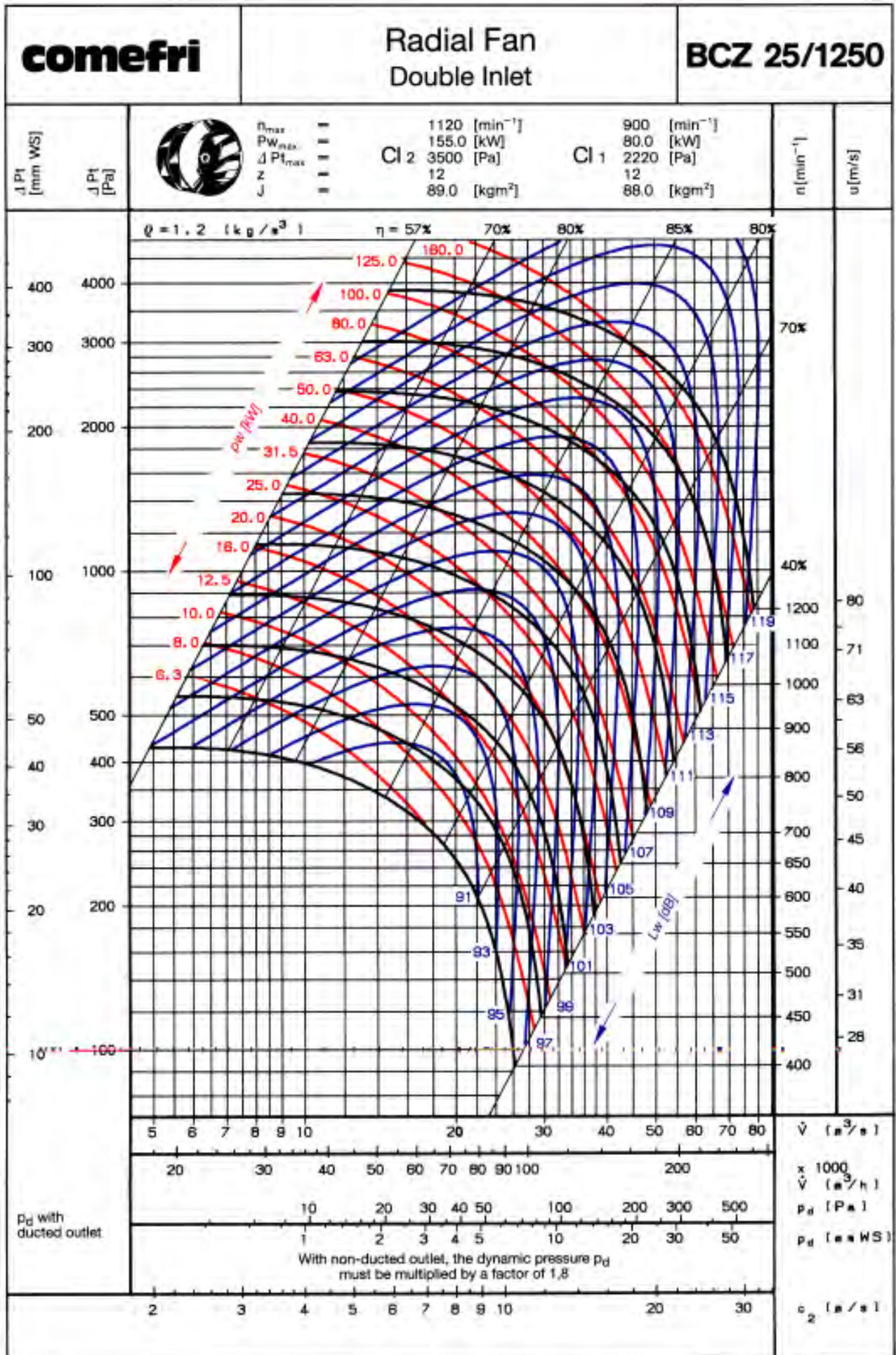

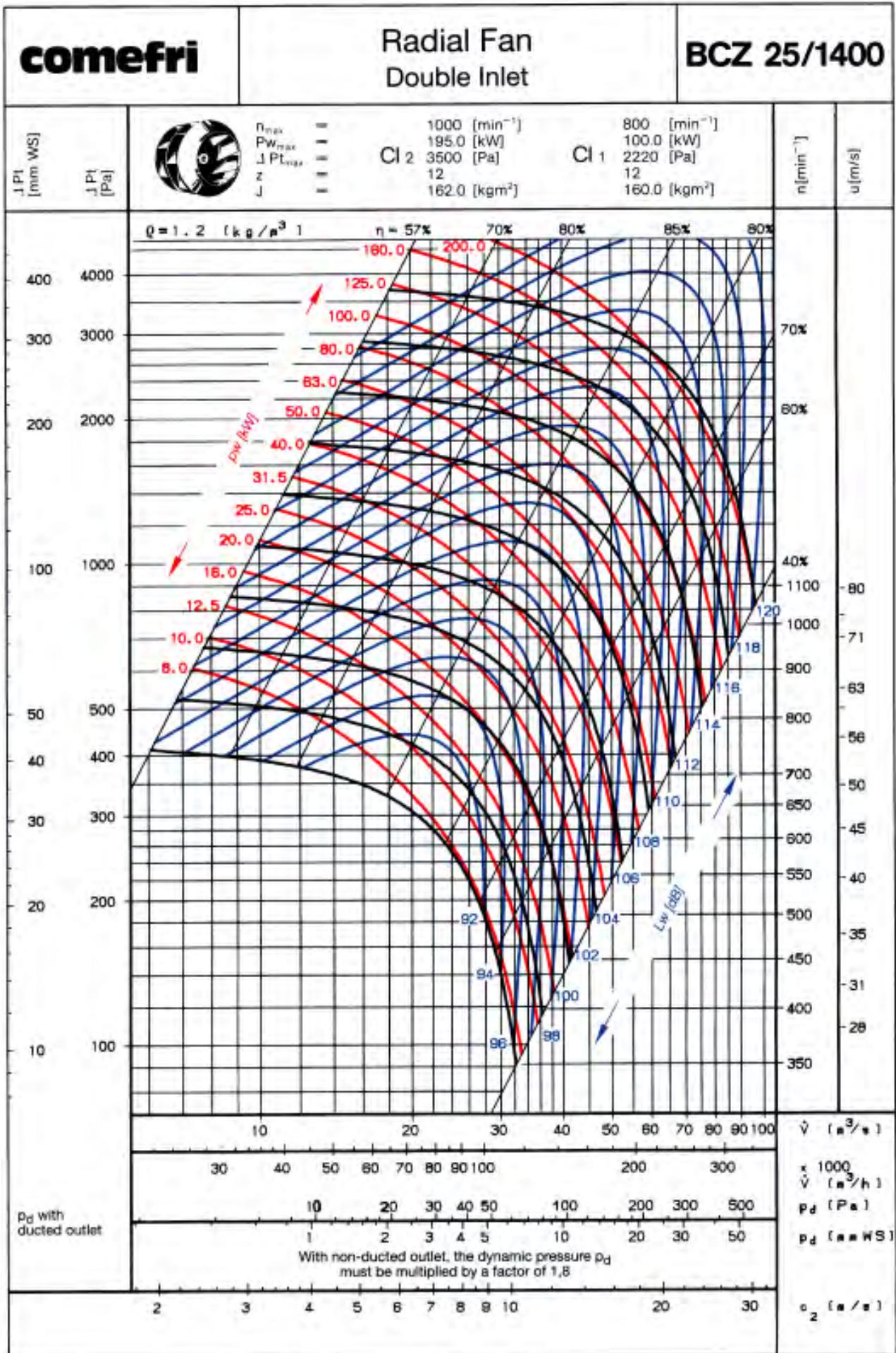

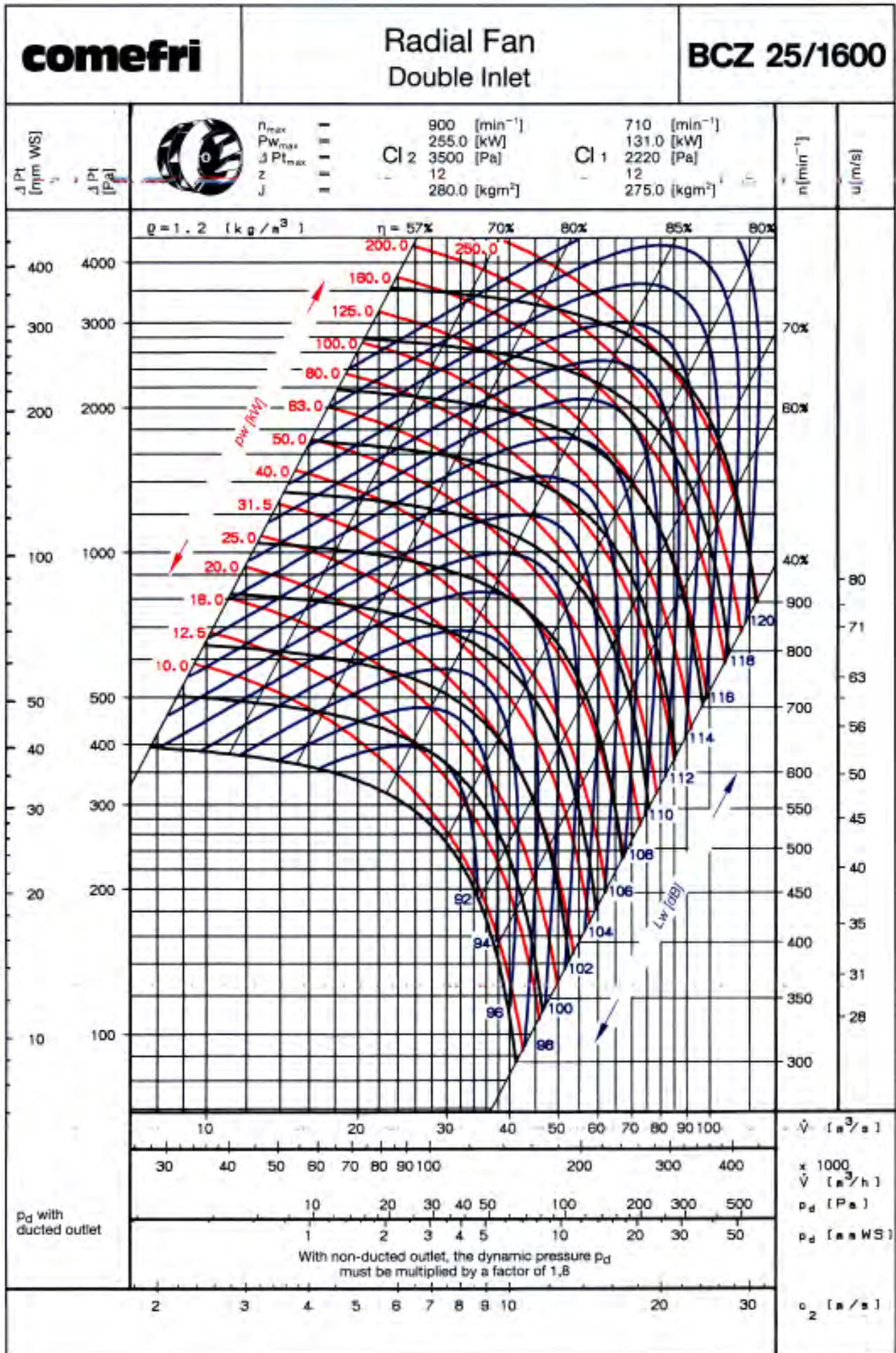

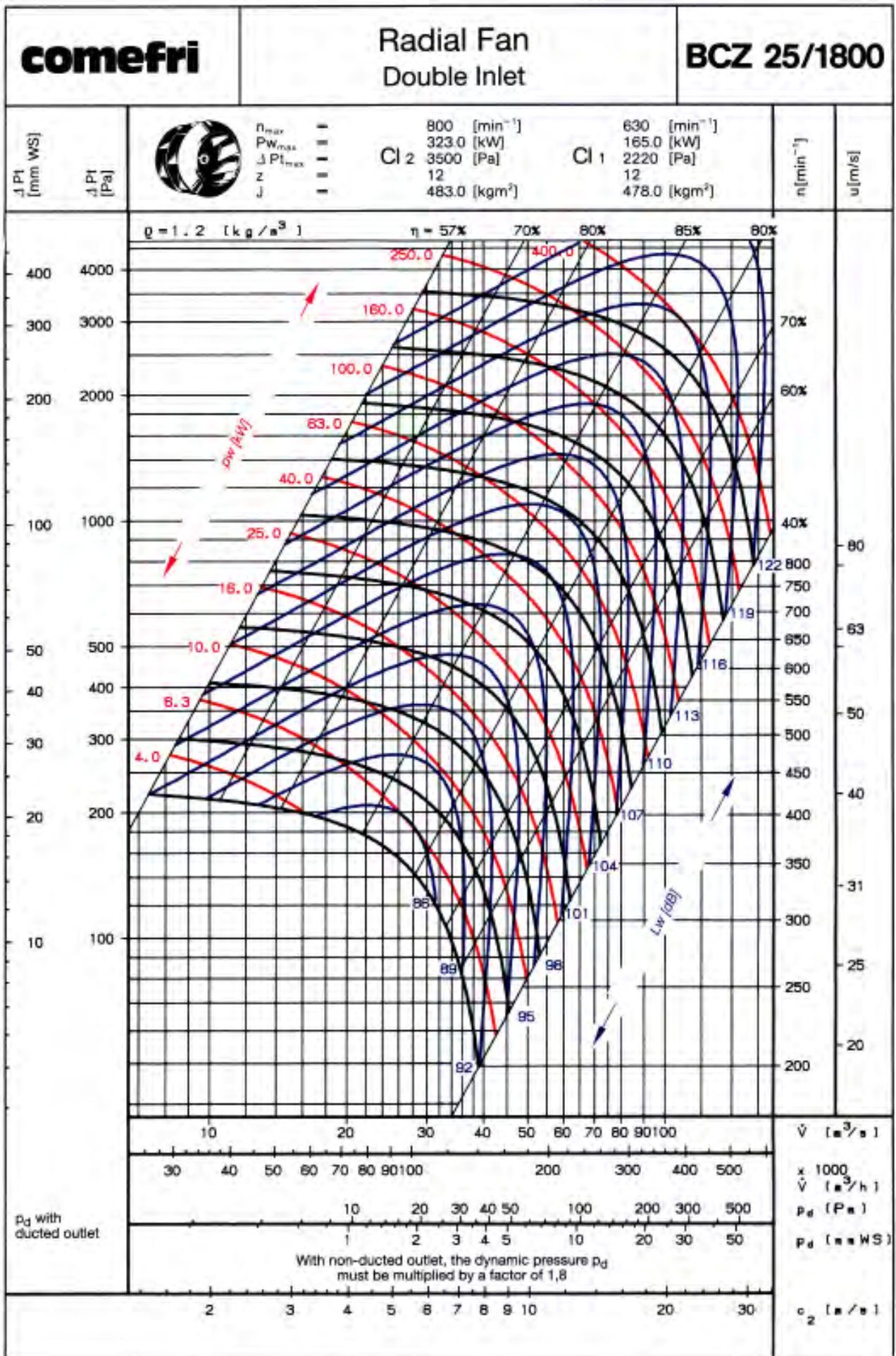

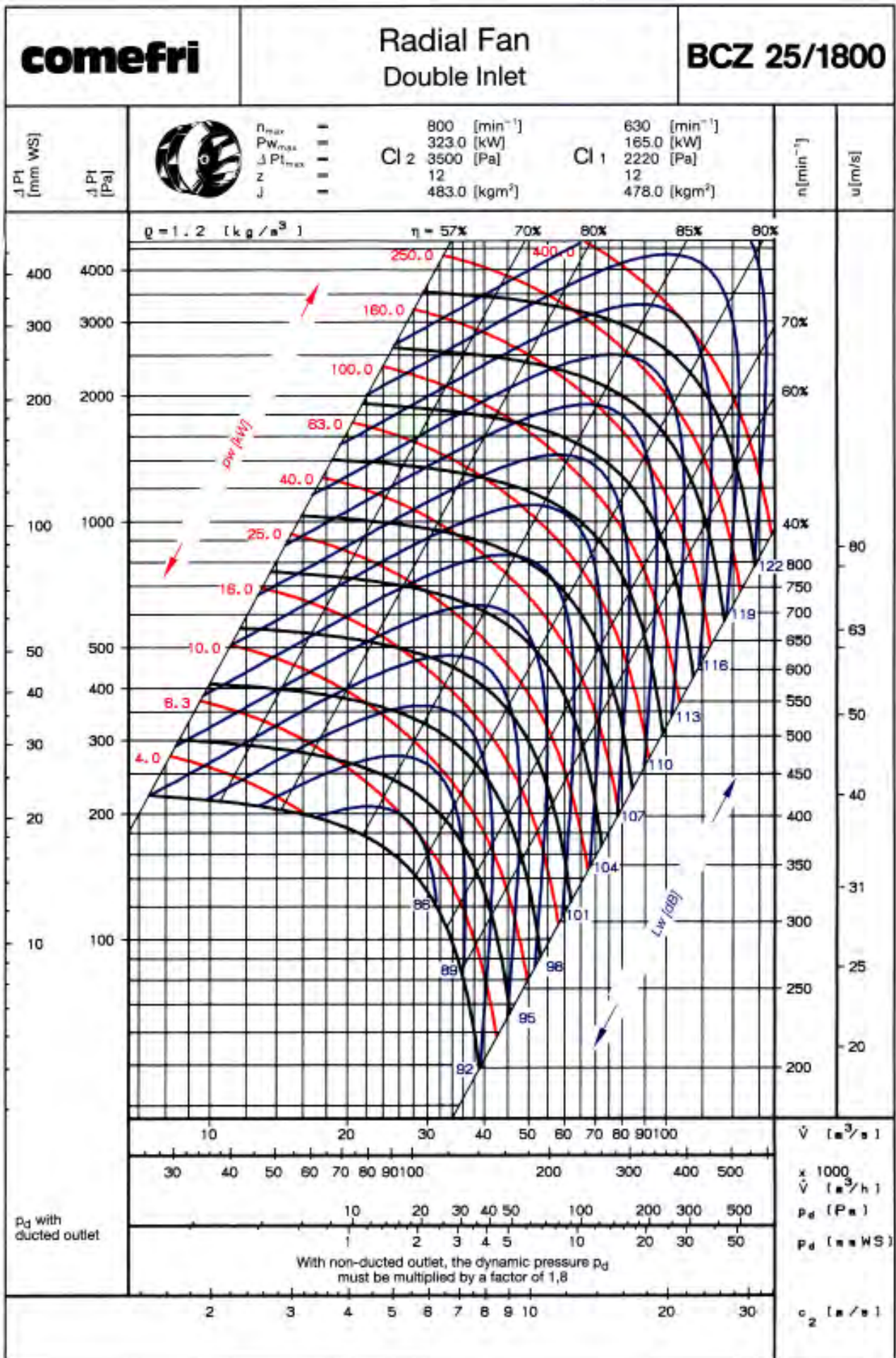

comefri

19. ACCESSORIES

- DAMPER
- FLEXIBLE OUTLET CONNECTION
- DRAIN PLUG
- INSPECTION DOOR
- OUTLET AND INLET GUARD
- BELT GUARD
- SHAFT GUARD
- ANTI-VIBRATION MOUNTS
- INLET VANE CONTROL
- BASE FRAME

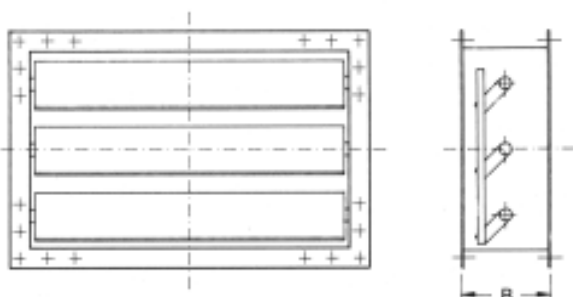
comefri**Damper - DKL**

The damper connection dimensions are determined according to the dimensions of a given fan size. The damper control can be achieved with a manual, pneumatic or electric device.

For all fan sizes, the length denoted by "B" is 250 mm.

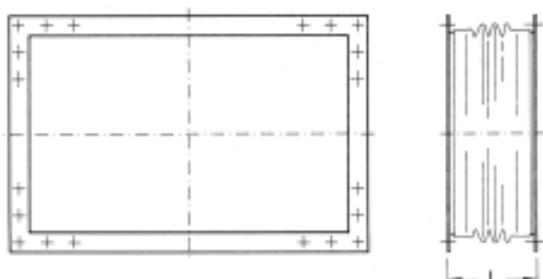
Flexible outlet connection- AEL

The flexible outlet connection, in standard execution, is manufactured in PVC (up to 80° C). Special executions reaching 200° C can be provided in reinforced fibreglass or in accordance with the client's specifications.

The length, denoted by "L" and valid for all fan sizes, is 155 mm.

All further connection dimensions are determined according to the given fan size dimensions.

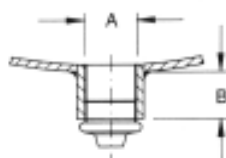
Drain plug - K

The drain plug positioning depends, in general, on the lowest point of the fan casing or according to the client's specification.

- 1) Fan size 400 ÷ 1000
A = 1/2" B = 17 mm
- 2) Fan size 1120 ÷ 2000
A = 1" B = 22 mm

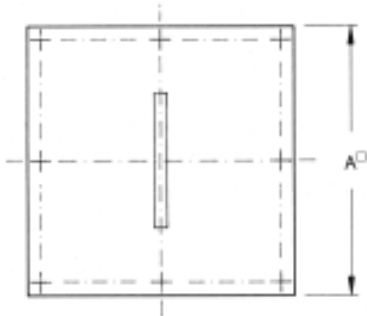
comefri**Inspection door - I**

Fan size

	400 ÷ 500	560 ÷ 710	800 ÷ 1000	1120 ÷ 2000
A	200	280	400	560

The inspection door can only be opened with appropriate tools.

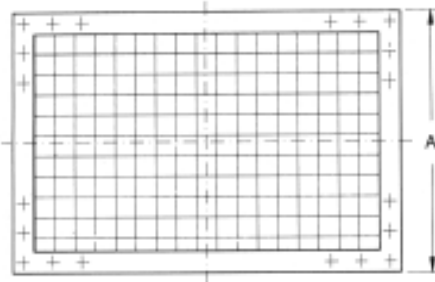
Outlet guard - AS

Connection dimensions correspond to the dimensions of a given fan size.

- 1) $A \leq 710$ mm grill size 10 x 10
- 2) $A > 710$ mm grill size 40 x 40

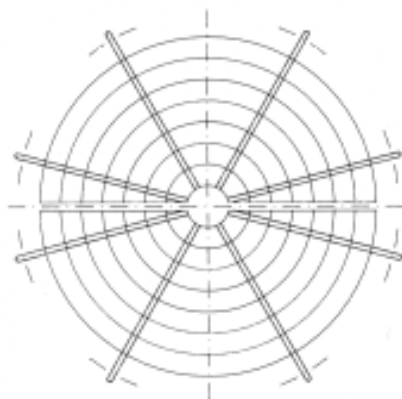
Inlet guard - ZS

Connection dimensions correspond to the dimensions of a given fan size.

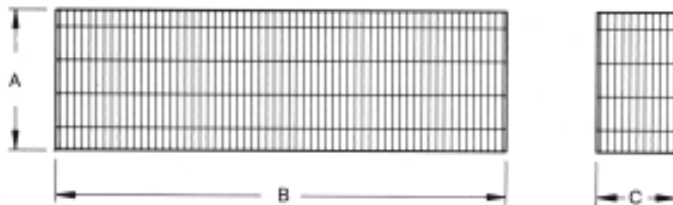
comefri**Belt guard - RIS**

The 8 mm x 60 mm belt guard is manufactured in galvanized steel. The dimensions denoted "A", "B" and "C" depend upon the corresponding pulley diameters, the number of belts and the motor size. Upon request corresponding inspection doors can be provided.

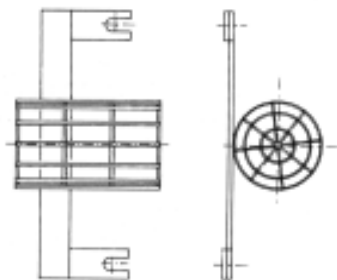
Shaft guard - WES

The 8 mm x 60 mm shaft guard is manufactured in galvanized steel. The dimensions result from the corresponding dimensions of the bearing block.

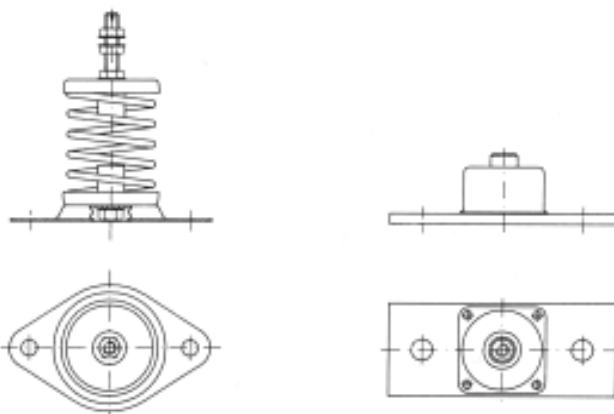
Anti-vibration mounts - DAM & DAG (respectively)

Spring anti-vibration mount - DAM

Rubber anti-vibration mount - DAG

Due to the fan's rigid construction and high balance level at two levels a good absorption of the vibrations can be obtained. In addition, anti-vibration mounts are available in rubber or in a spring form. Flexible inlet and outlet connections must be used to avoid vibrations from being transferred to the system.

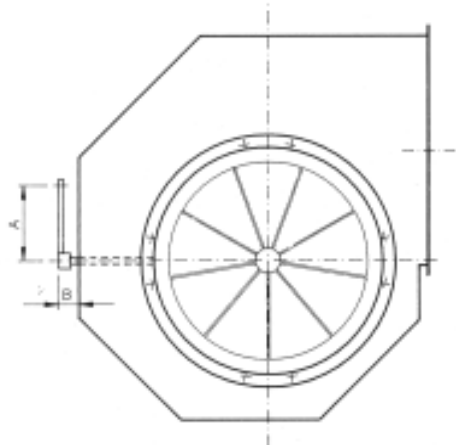
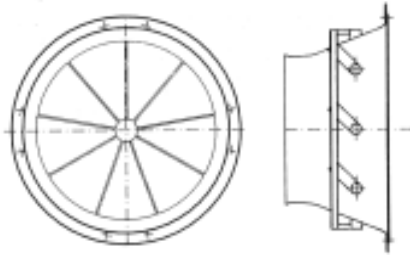
comefri**Inlet vane control - DRD**

The inlet vane control connection dimensions are determined according to the dimensions of a given fan size.

The movement control can be provided with a manual, pneumatic or electric device.

Size	A	B
400	185	80
450-630	235	80
710-1250	285	80
1400-2000	350	80

Maximum torque required for inlet vane control operation is:

Size	
400	10
450	12
500	12
560	12
630	18
710	18
800	26
900	36
1000	40
1120	upon request
1250	upon request
1400	upon request
1600	upon request
1800	upon request
2000	upon request

comefri



Base Frame - GR

For RD LG rotation and 0° 45° 90°
135° 270° 315° discharge position

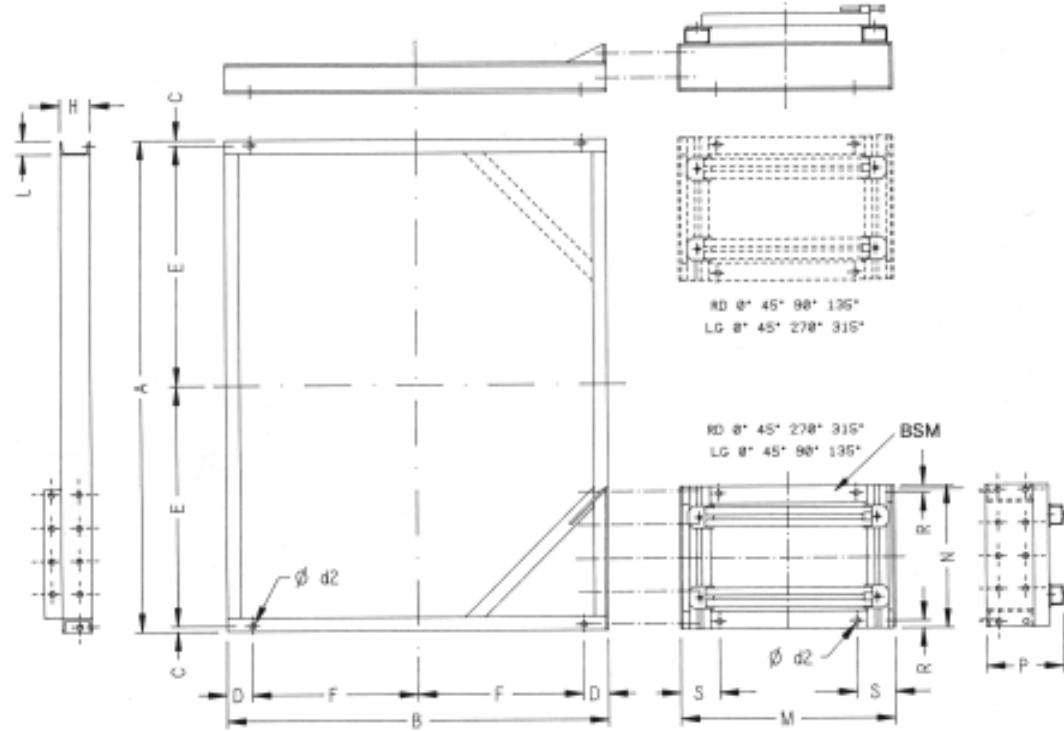

Fan size	400	450	500	560	630	710	800	900	1000	1120	1250	1400	1600	1800	2000
A	718	818	908	1030	1130	1271	1446	1616	1814	1968	2190	2440	2702	3061	3441
B	538	596	660	694	780	870	994	1110	1220	1360	1520	1700	1950	2200	2450
C	15	15	15	15	18	18	18	18	18	25	25	30	25	36	36
D	80	80	80	80	80	80	80	80	80	80	80	80	80	80	80
E	344	394	439	500	547	618	705	790	889	959	1070	1190	1326	1495	1685
F	189	218	250	267	310	355	417	475	530	600	680	770	895	1020	1145
L	38	38	38	42	42	45	45	50	50	55	55	60	60	70	70
H	50	50	50	65	65	80	80	100	100	120	120	140	140	180	180
d2	12	12	12	12	12	12	12	12	12	12	12	12	12	12	12
Weight Kg	19	20	23	31	34	46	51	69	77	103	118	155	172	231	255

BSM size	Z 1	Z 2	Z 3	Z 4	Z 5	Z 6
Motor size	80-112	132S-160L	180M-200Lb	225S-250M	280S-315Md	355Lx-355Ly
M	500	630	800	1050	1250	1600
N	280	470	570	685	910	1150
P	215	215	238	238	250	250
R	20	20	20	20	20	20
S	80	80	80	80	80	80
d2	12	12	12	12	12	12
Weight Kg	19	35	55	79	124	166

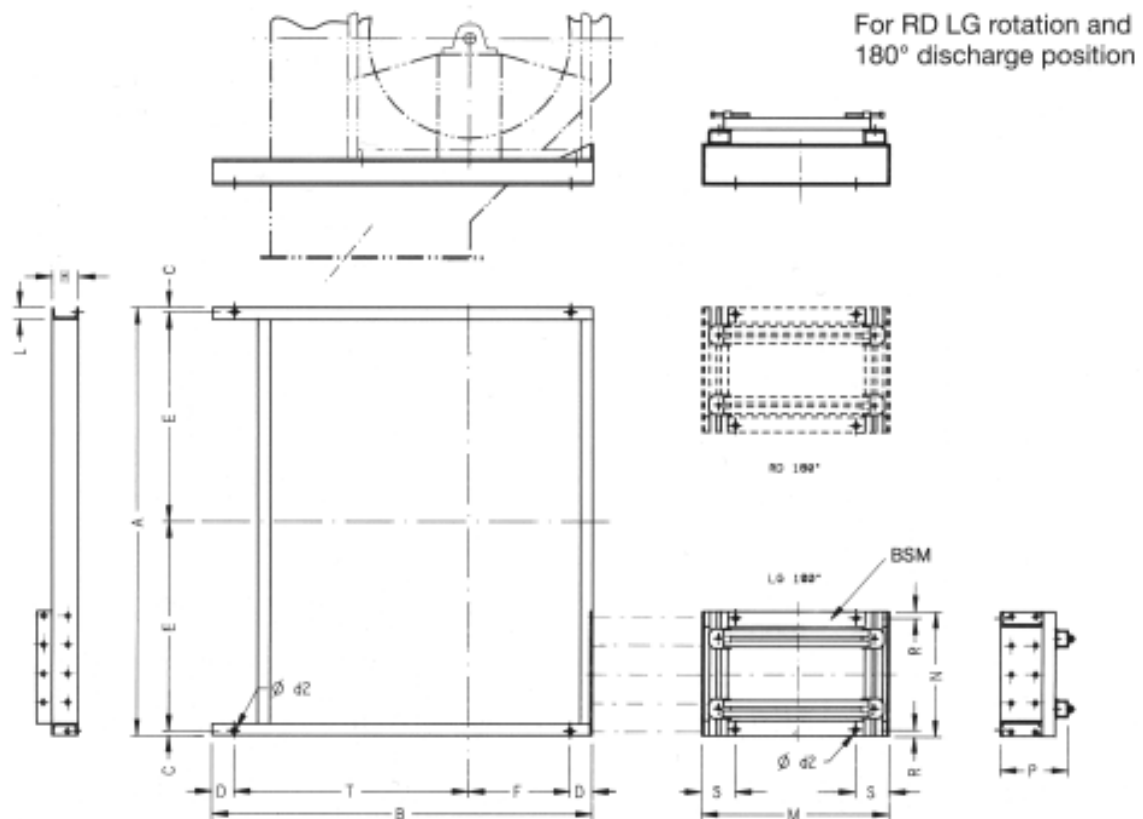
comefri

Grundrahmen für Drehrichtung LG/RD 180°

Fan size	400	450	500	560	630	710	800	900	1000	1120	1250	1400	1600	1800	2000
A	718	818	908	1030	1130	1271	1446	1616	1814	1968	2190	2440	2702	3061	3441
B	888	966	1053	1124	1237	1381	1533	1690	1844	1988	2199	2440	2866	3193	3519
C	15	15	15	15	18	18	18	18	18	25	25	30	25	36	36
D	80	80	80	80	80	80	80	80	80	80	80	80	80	80	80
E	344	394	439	500	547	618	705	790	889	959	1070	1190	1326	1495	1685
F	189	218	250	267	310	355	417	475	530	600	680	770	895	1020	1145
L	38	38	38	42	42	45	45	50	50	55	55	60	60	70	70
H	50	50	50	65	65	80	80	100	100	120	120	140	140	180	180
T	539	588	643	697	767	866	956	1055	1154	1228	1359	1510	1811	2013	2214
d2	12	12	12	12	12	12	12	12	12	12	12	12	12	12	12
Weight Kg	22	24	26	35	38	54	60	80	88	122	134	177	235	311	393

BSM size	Z 1	Z 2	Z 3	Z 4	Z 5	Z 6
Motor size	80-112	132S-160L	180M-200Lb	225S-250M	280S-315Md	355Lx-355Ly
M	500	630	800	1050	1250	1600
N	280	470	570	685	910	1150
P	215	215	238	238	250	250
R	20	20	20	20	20	20
S	80	80	80	80	80	80
d2	12	12	12	12	12	12
Weight Kg	19	35	55	79	124	166

comefri**20. WEIGHTS**

Size	Approx. weight in Kg
400	121
450	147
500	181
560	228
630	301
710	379
800	604
900	731
1000	930
1120 cl 1	1145
1120 cl 2	1205
1250 cl 1	1375
1250 cl 2	1461
1400 cl 1	1813
1400 cl 2	1880
1600 cl 1	2474
1600 cl 2	2544
1800 cl 1	3214
1800 cl 2	3266
2000 cl 1	3968
2000 cl 2	4036

Weights without accessories

comefri

21. CUSTOM-MADE DESIGNS

Custom-made designs can be tailored to meet particular customer specifications, such as:

- multiple split fan casings
- corrosion resistant steel
- high tensile steel
- sandblasting and protective special coating
- hot dipped galvanising
- aluminium finishing
- sound insulation
- chemical resistant

We reserve the right to modify fan designs or dimensions in order to enhance our products.

comefri

22. COMPLETED ORDER EXAMPLE

Industrial Radial Fan BCZ

Double inlet, continuously welded casing from solid sheet steel, heavy duty execution.
 Radial impeller with backwards curved continuously welded blades, primed and finished, statically and dynamically balanced, minimum quality level Q=6,3.
 Solid bearing support with regreasable roller bearings are mounted on a solid pedestal.

Fan type	BCZ	
Discharge position		
Setting		
Air flow	V =	m ³ /h
Total pressure	$\Delta p_t =$	Pa
Airflow temperature	t =	°C
Absorbed shaft power	$P_w =$	KW
Efficiency	$\eta =$	%
Speed	n =	min ⁻¹
Maximum allowable speed	$n_{max} =$	min ⁻¹
Sound pressure level	$L_w =$	dB

Accessories and special executions (at additional cost):

- Outlet flange
- Inlet or outlet guard
- Guard
- Shaft guard
- Inspection door
- Drain plug
- Inlet vane control
- Damper
- Inlet box
- EX- anti-spark execution
- Complete belt drive
- Anti-vibration mounts
- Split housing
- Base frame
- Special coating or finish



comefri



**COOKE
INDUSTRIES**

Auckland (Head Office)
31 Station Road, Penrose, Auckland, NZ
PO Box 12021, Penrose, Auckland 1642
Ph: +64-9-579 2185 Fax: +64-9-579 2181

Christchurch (Branch Office)
Level 3, 161 Kilmore Street, Christchurch, NZ
PO Box 13516, Armagh, Christchurch 8141
Ph: +64-3-379 7884 Fax: +64-3-379 7874

Web: www.cookeindustries.co.nz Email: sales@cookeindustries.co.nz

EXAMPLES OF COMEFRI'S INDUSTRIAL FANS

BCZ 25/2000 double inlet radial fan
Airflow: 310 000 m³/h - Total pressure 1922 Pa
Speed: 590 rpm
Absorbed shaft power: 206 kW
Motor: 250 kW - 4 pole



BCE 25/1000 single inlet radial fan
Stainless steel AISI 316
Airflow: 58 700 m³/h - Total pressure 4020 Pa
Speed: 1780 rpm
Absorbed shaft power: 40,4 kW
Motor: 90 kW - 4 pole
Operating temperature: 300°C



AVH 1250 direct coupled axial fan with silencer
Airflow: 126 000 m³/h - Total pressure 1962 Pa
Absorbed shaft power: 82 kW
Motor: 90 kW - 4 pole



BCZ 15/560 radial fan with inlet boxes
Airflow: 16 000 m³/h - Total pressure 1864 Pa
Speed: 1990 rpm
Absorbed shaft power: 9,8 kW
Operating temperature: 350°C